



# Standard Test Method for Determining Modulus, Tear and Adhesion Properties of Precured Elastomeric Joint Sealants<sup>1</sup>

This standard is issued under the fixed designation C 1523; the number immediately following the designation indicates the year of original adoption or, in the case of revision, the year of last revision. A number in parentheses indicates the year of last reapproval. A superscript epsilon ( $\epsilon$ ) indicates an editorial change since the last revision or reapproval.

## 1. Scope

1.1 This test method describes a laboratory procedure for measuring modulus, tear, joint movement ability and adhesion properties of applied, Precured Elastomeric Joint Sealants, hereinafter referred to as “applied seal” and if not applied, hereinafter referred to as “seal,” on portland cement mortar as a standard substrate and or other substrates. It tests these properties after dry, wet, frozen, heat aged or artificially weather-aged conditionings, or both.

1.2 The values stated in SI units are to be regarded as the standard. Other values given in parentheses are provided for information only.

1.3 *This standard does not purport to address all of the safety concerns, if any, associated with its use. It is the responsibility of the user of this standard to establish appropriate safety and health practices and determine the applicability of regulatory limitations prior to use.*

1.4 The committee with jurisdiction over this standard is not aware of any similar standard published by another committee or organization.

## 2. Referenced Documents

### 2.1 ASTM Standards:

C 717 Terminology of Building Seals and Sealants<sup>2</sup>

C 1375 Guide for Substrates Used in Testing Building Seals and Sealants<sup>2</sup>

D 1566 Terminology Relating to Rubber<sup>3</sup>

G 113 Terminology Relating to Natural and Artificial Weathering Tests of Nonmetallic Materials<sup>4</sup>

G 151 Practice for Exposing Nonmetallic Materials in Accelerated Test Devices That Use Laboratory Light Sources<sup>4</sup>

G 154 Practice for Operating Fluorescent Light Apparatus for UV Exposure of Nonmetallic Materials<sup>4</sup>

<sup>1</sup> This test method is under the jurisdiction of ASTM Committee C24 on Building Seals and Sealants and is the direct responsibility of Subcommittee C24.30 on Adhesion.

Current edition approved May 10, 2002. Published May 2002. Originally published as C 1523–02. Last previous edition C 1523–02.

<sup>2</sup> *Annual Book of ASTM Standards*, Vol 04.07.

<sup>3</sup> *Annual Book of ASTM Standards*, Vol 09.01.

<sup>4</sup> *Annual Book of ASTM Standards*, Vol 14.04.

G 155 Practice for Operating Xenon Arc Light Apparatus for Exposure of Nonmetallic Materials<sup>4</sup>

## 3. Terminology

3.1 *Definitions*—Refer to Terminology C 717 for definitions of the following terms used in this test method: adhesive failure, cohesive failure, primer, modulus, and to Terminology D 1566 for tear and to Terminology G 113 for definitions related to artificial weathering.

## 4. Summary of Test Method

4.1 Model joints are prepared, the seal is adhered to the substrate utilizing an adhesive sealant specified by the manufacturer, hereinafter referred to as adhesive, then exposed to a variety of conditionings such as heat, cold, artificial weathering or water immersion. A specific set of specimens can go through each conditioning or separate specimens can be used for each conditioning. After exposure the test specimens are subjected to an elongation (strain) and held at this elongation for as long as is desired. The elongation (joint expansion) is performed with a tensometer to obtain tensile-forces during the pull. One aspect of the test has the applied seal cut in the middle of the joint and then elongated and the degree of tear propagation noted. After the initial strain the samples can be subjected to cycles of repeated strain. The samples can also be tested to destruction. The movement test and tear test can be done on separate sets of test specimens or done sequentially with the same test specimen.

## 5. Significance and Use

5.1 Seals are manufactured in flat extruded shapes and are primarily used to span joint openings. The seal is adhered to construction substrates utilizing a liquid applied adhesive, to seal building openings such as panel joints, metal flashing joints or other joints in place of conventional liquid applied sealants. In actual use, failure of an applied seal in an active joint is usually manifested by cohesive failure of the seal; adhesive failure between the adhesive and the substrate; adhesive failure between the adhesive and the seal; cohesive failure of the substrate or tear propagation parallel to the joint length.

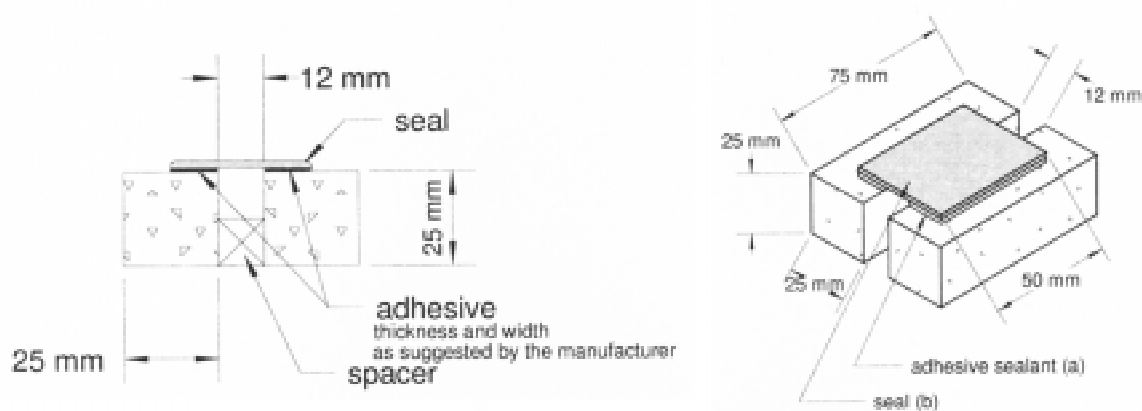

FIG. 1 Standard Substrate Test Specimen Assemblies

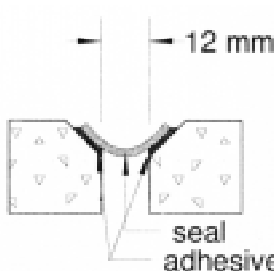

FIG. 2 Beveled Bridge Joint Configuration

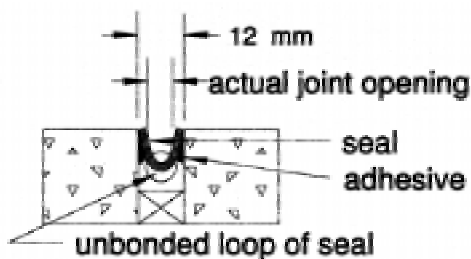

FIG. 3 U-joint Configuration

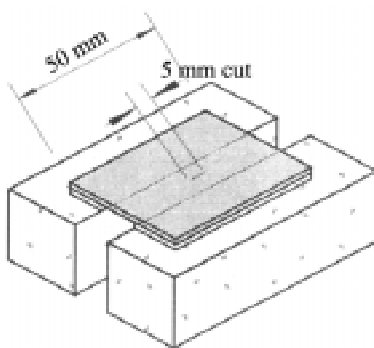

FIG. 4 Test Specimen Showing 5 mm Cut in the Middle of the Seal for Tear Propagation Testing

5.2 This test method can be used for testing the adhesion of the adhesive to the substrate and to the seal, tensile load at various strains and tear resistance at various strains after the specimens are exposed to wet, cold, hot and artificial weath-

ering conditionings. All or some of these properties are experienced on actual job sites.

## 6. Apparatus and Materials

6.1 *Tensile Testing Machine*, capable of producing a tensile load on the specimen at a rate of  $50 \pm 5$  mm ( $2.0 \pm 0.20$  in.)/min., and with a recording chart to show load strain values (tensile modulus).

6.1.1 *Fixed Member*—A fixed or essentially stationary member carrying one grip.

6.1.2 *Movable Member*—A movable member carrying one grip.

6.1.3 *Grips*—The grips should be suitable to firmly grasp the test fixture that holds the test specimen.

6.1.4 *Grip Fixture*—A fixture capable of being held by the grips and furnishing a tensile force to the sealant specimen.

6.2 *Spatulas*, for use in applying the adhesive.

6.3 *Caulking Gun*, for extruding adhesive from cartridges.

6.4 *Primer*, if applicable.

6.5 *Adhesive*.

6.6 *Seal*.

6.7 *Spacer*—Pieces of rigid material that help to maintain a joint opening of 12 mm (0.5 in.) while preparing the test specimen.

6.8 *Substrates*—2 substrate samples are required for each test specimen. The substrate sample size shall be determined by the size of the test machine grips, yet they must be of a size to allow the application of a  $50 \pm 5$  mm ( $2 \pm 0.2$  in.) long seal.

6.9 *Freezer*,  $-18 \pm 2^\circ\text{C}$  ( $0 \pm 3.6^\circ\text{F}$ ).

6.10 *Oven*,  $70 \pm 2^\circ\text{C}$  ( $158 \pm 3.6^\circ\text{F}$ ).

6.11 *Apparatus*, in accordance with Practice G 151 and G 154, or G 155 and C 1442.

6.12 *Stencil Knife*, or similar instrument (5 mm cutting width).

## 7. Test Specimen

7.1 The standard joint configuration used in this test method shall be the bridge joint application as shown in Fig. 1.

NOTE 1—Other joint configurations such as beveled bridge joint application and/or U-joint application in place or in addition to the standard joint configuration may be specified for the test with the seal sample. While the beveled bridge joint application (Fig. 2) is similar in function

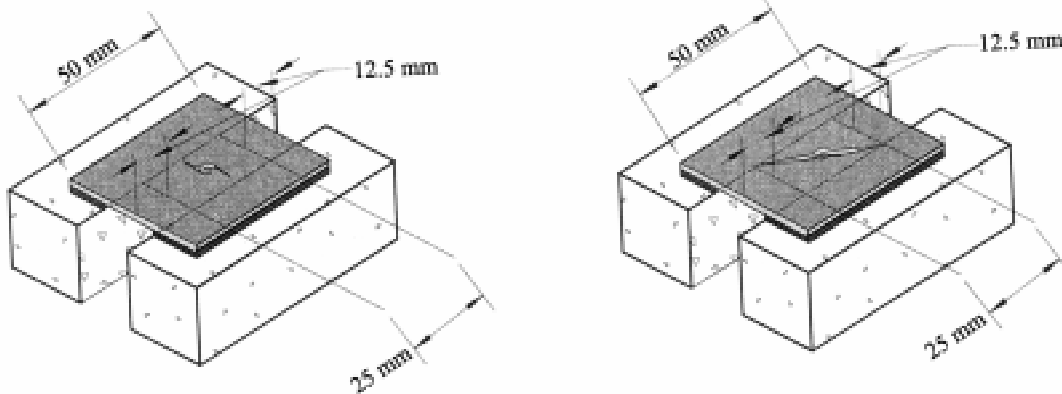

Tear propagates perpendicular to the length of the joint as shown above, left; or at any angle leading to the joint wall as shown above, right. In each case tear stops at the joint wall with an intact unbroken joint length on both sides of at least 12.5 mm.

FIG. 5 Partial Tear

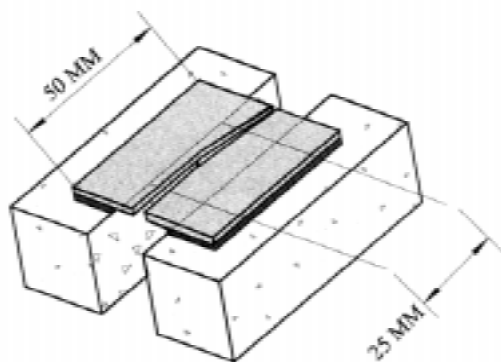

Tear propagates parallel to the joint wall and opens one side or both sides.

FIG. 6 Tear

and the calculation of test values to the standard joint configuration, different considerations have to be taken into account with the U-joint application (Fig. 3): (1) The actual joint opening of 12 mm (0.5 in.) will be reduced by the thickness of the seal and the adhesive, and (2) The size of the unbonded loop of the seal determines to a great extent the flexibility and expandability of the seal (Fig. 3).

7.2 Two substrate samples are required for each test specimen assembly as shown in Fig. 1.

7.2.1 *Initial Joint Opening (Width)*—Standard opening (width) for this test is 12 mm (0.5 in.).

NOTE 2—Joint openings other than the standard width may be specified for the test with the seal sample.

7.2.2 *Length of Applied Seal*—Standard length for this test is 50 mm (2 in.).

7.3 The standard substrate used in this test method shall be portland cement mortar.

NOTE 3—Other substrates such as EIFS, brick, wood, aluminum, plastic, metal or other in place or in addition to the standard substrate may be specified for the test with the seal sample. Any substrate other than the standard substrate has to be sized to fit the testing equipment.

7.3.1 *Mortar Block*—Prepare mortar blocks according to Section 7 of Guide C 1375.

7.4 *Preparation of Test Specimen*—Condition substrates, adhesive, (and primer if needed) and seal for at least 24 h at

standard conditions. Prime the substrate surface if required. Apply the adhesive at a specified thickness and width according to the manufacturers suggestion on the surface of the substrate, next to the joint opening and apply the seal into the wet adhesive according to the manufacturers suggestion while maintaining a joint opening of 12 mm (0.5 in.) as shown in Fig. 1.

NOTE 4—Care must be taken to bring the adhesive neatly to the edge of the test block and extra adhesive should be cleaned of the bridging section of the seal.

NOTE 5—Three test specimen assemblies per condition should be prepared for each substrate and each desired test(s) (Modulus/Adhesion or Tear, or both). It may be beneficial to prepare three extra specimen assemblies in the event one or more samples are unusable.

## 8. Conditioning

8.1 Condition (cure or set up time for adhesive) specimens for 21 days (or for a shorter time if indicated by the manufacturer) at standard conditions of  $23 \pm 2^\circ\text{C}$  ( $73.4 \pm 3.6^\circ\text{F}$ ) and  $50 \pm 5\%$  relative humidity.

8.2 Following completion of the cure or set up of the adhesive as outlined in 8.1, test specimen samples after the following separate conditionings:

8.2.1 *Dry/Room Temperature*—Test samples at  $23 \pm 2^\circ\text{C}$  ( $73.4 \pm 3.6^\circ\text{F}$ ).

8.2.2 *Water Immersion*—Completely immerse test specimens in distilled or deionized water for 24 h or any multiple of 24 h at  $23 \pm 2^\circ\text{C}$  ( $73.4 \pm 3.6^\circ\text{F}$ ). Remove specimens one at a time. Start testing each specimen immediately (within one hour) after removal from water.

8.2.3 *Frozen*—Condition specimens in a  $-18 \pm 2^\circ\text{C}$  ( $0 \pm 3.6^\circ\text{F}$ ) freezer for 24 h or any multiple of 24 h. Remove specimens one at a time. Start testing each specimen immediately (start test within 3 min) after removal from the freezer.

NOTE 6—Temperatures lower than noted in 8.2.3 may be specified for the test with the Seal sample.

8.2.4 *Heat*—Condition specimens in a  $70 \pm 2^\circ\text{C}$  ( $158 \pm 3.6^\circ\text{F}$ ) oven for 24 h or any multiple of 24 h. Remove specimens one at a time. Start testing each specimen immediately (start test within 3 min) after removal from the oven.

NOTE 7—Temperatures higher than noted in 8.2.4 may be specified for the test with the Seal sample.

8.2.5 *Artificial Weathering*—Use apparatus and conditions that conform to the requirements defined in Practices G 151 and either G 154 or G 155 unless otherwise agreed on or specified.

8.2.5.1 *Fluorescent UV Apparatus*—Use the exposure conditions and lamp described in Practice G 154, Table X2.1, UVA-340 lamp, Cycle 1:8 h UV at  $60 \pm 3^\circ\text{C}$  ( $140 \pm 5.4^\circ\text{F}$ ) uninsulated black panel temperature, 4 h condensation at  $50 \pm 3^\circ\text{C}$  ( $122 \pm 5.4^\circ\text{F}$ ) uninsulated black panel temperature. Unless otherwise specified, irradiance at the control point when using the irradiance controlled apparatus shall be maintained at  $0.73 \pm 0.05 \text{ W}/(\text{m}^2 \cdot \text{nm})$  at 340 nm.

NOTE 8—The irradiance in the device that does not have irradiance control is reported to be  $0.73 \pm 0.12 \text{ W}/(\text{m}^2 \cdot \text{nm})$  at 340 nm at an operating temperature of  $60^\circ\text{C}$ . However, the degradation rate has been found to be very variable between replicate exposures.

8.2.5.2 *Xenon Arc Light Apparatus*:

(1) Use daylight filters and exposure cycle described in Practice G 155, Table X3.1: 102 min light at  $63 \pm 3^\circ\text{C}$  ( $145 \pm 5^\circ\text{F}$ ) uninsulated black panel temperature followed by 18 min light plus either water spray on the front surface or water immersion.

(2) The typical temperature of water used for specimen spray is  $21 \pm 5^\circ\text{C}$ , but may be lower if ambient water temperature is low and a holding tank is not used to store purified water. The immersion water is kept at a constant temperature, which shall be less than  $40^\circ\text{C}$ .

(3) Use an irradiance level at the control point of  $0.50 \text{ W}/(\text{m}^2 \cdot \text{nm})$  at 340 nm maintained at a tolerance of  $\pm 0.02 \text{ W}/(\text{m}^2 \cdot \text{nm})$ .

NOTE 9—The equivalent nominal broad band irradiances are  $55 \pm 3.5 \text{ W}/\text{m}^2$  at 300–400 nm and  $530 \pm 30 \text{ W}/\text{m}^2$  at 300–800 nm. These values are based on the average of measurements of different instrument types and ages of lamps and filters. For a more precise specification for the device used, consult the instrument manufacturer.

(4) Unless otherwise specified, apparatus equipped with a means of humidification shall be operated to maintain the RH at  $50 \pm 10\%$  at the control point during the light only period.

(5) The air chamber temperature shall be maintained at the control point at  $48 \pm 2^\circ\text{C}$  in devices that allow for its control.

8.2.5.3 The minimum exposure in the artificial weathering machine is 2500 h and additional exposure is in 500 h increments. Position the specimens with the sealant facing the light source. After exposure remove specimens one at a time and start testing each specimen immediately (within one hour).

NOTE 10—Note in test report (10.1.11.1) which Standard Practice and what Weathering Apparatus for Artificial Weathering was used.

## 9. Testing Procedure

9.1 *For Movement, Cohesion and Adhesion (Bond-Line Force) Testing*—Measure and record the actual initial joint opening and length of applied seal prior to loading of test specimen into equipment. Secure specimen in the grips of the tensile testing machine and extend at a rate of  $50 \pm 5 \text{ mm}$  ( $2 \pm 0.2 \text{ in.}$ )/min to a preset elongation of  $X\%$ , of the initial joint opening. Where  $X$  is 12.5 % or a multiple of 12.5 % and hold

for 1 h and or additional 1 h segments. Record the initial tensile load and the tensile load after the holding time at the maximum set elongation. After extension, relax the sample, inspect the tested specimen and measure/record the largest depth of loss of adhesion or cohesion of adhesive or seal, or both, if either occurs.

NOTE 11—When inspecting for loss of adhesion or cohesion of adhesive or seal, or both, this is most easily done by folding back the test assembly to expose the bond line. Failures should be measured to the nearest half millimeter.

9.2 After the inspection of the test specimen secure the same assembly in the grips of the tensile testing machine and extend at a rate of  $50 \pm 5 \text{ mm}$  ( $2 \pm 0.2 \text{ in.}$ )/min until the seal breaks (seal ruptures or 100 % cohesive or adhesive failure of adhesive). Record elongation and load (at peak load).

9.3 Other coincidence points may be recorded as desired.

9.4 *For Tear Propagation Testing*—Follow the same procedure as described in 9.1. Before starting test, make a 5 mm cut in the middle of the seal parallel to the joint wall with a stencil knife or similar instrument (see Fig. 4). Record kind of tear if any (optional document with camera or a sketch and include in report): NT: No Tear; PT: Partial Tear (Fig. 5); T: Tear (Fig. 6).

9.5 Record any type of failure other than those listed.

## 10. Report

10.1 The report shall include the following information for each sample tested:

- 10.1.1 Seal identification.
- 10.1.2 Adhesive identification.
- 10.1.3 Primer identification.
- 10.1.4 Substrate identification.
- 10.1.5 Joint configuration.
- 10.1.6 In case of a U-joint configuration: length of loop.

NOTE 12—The length of the loop can be measured easily with a piece of paper, by aligning the paper on top of the loop, mark the unbonded length and measure.

- 10.1.7 Actual initial joint opening.
- 10.1.8 Applied bond depth.
- 10.1.9 Applied adhesive thickness.
- 10.1.10 Actual seal length.
- 10.1.11 Actual conditioning.
  - 10.1.11.1 Artificial weathering test used.

NOTE 13—Refer to Practice G 151 for information required in the report section.

- 10.1.12 Actual conditioning time.
- 10.1.13 Surface preparation.
- 10.1.14 *Tensile Adhesion Testing Data*:
  - 10.1.14.1 Tested strain.
  - 10.1.14.2 *Modulus*—Tensile load over length of joint in N/mm (lb/in.) at each segmented elongation point (12.5 %, 25 %, 37.5 %,.....).
  - 10.1.14.3 Percentage loss if any in bond depth at substrate/adhesive interface.
  - 10.1.14.4 Percentage loss if any in bond depth at seal/adhesive interface.
  - 10.1.14.5 Percentage loss if any in cohesion of adhesive.
  - 10.1.14.6 Kind of tear propagation as described in 9.4.



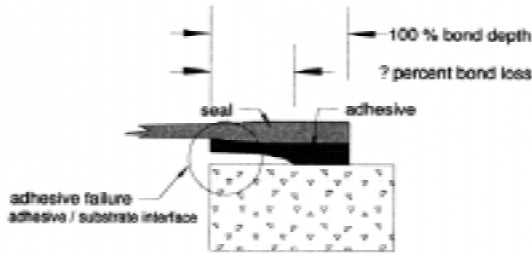

FIG. 7 Percentage Loss, If Any, in Bond Depth at Substrate/ Adhesive Interface

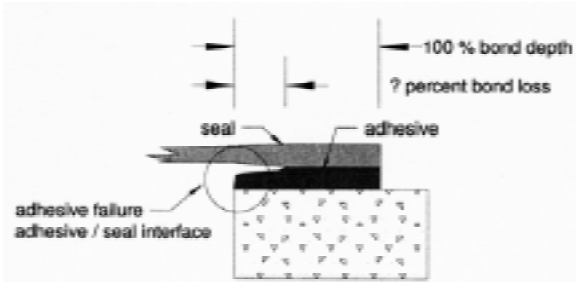

FIG. 8 Percentage Loss, If Any, in Bond Depth at Seal/Adhesive Interface

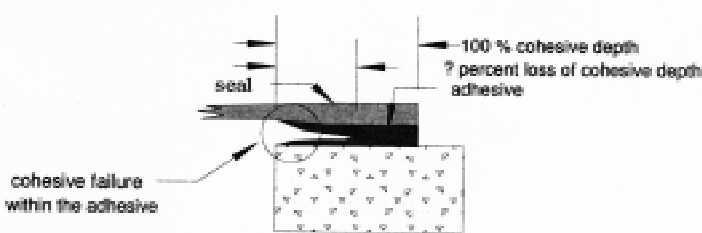

FIG. 9 Percentage Lose, if Any, in Cohesion of Adhesive

- 10.1.14.7 Strain at peak load.
- 10.1.14.8 Peak tensile load over length of joint in N/mm (lbs/in.).
- 10.1.15 Describe any substrate failure if any.
- 10.1.16 Variation, if any, from the test procedure.

**11. Precision and Bias**

11.1 The number of laboratories and materials in this study DOES NOT meet the minimum requirements for determining precision prescribed in Practice E 691.

	This Study	ASTM E 691 Minimum
Laboratories	3	6
Materials	2	4
Determinations	4	2

11.2 All laboratories used the same precured sealant (same lot no.), the same adhesive sealant (same lot no.) and the same substrate. The actual test specimens were assembled by each laboratory in reference to 7.1. All specimens were conditioned in reference to 8.1 for 7 days as required by the manufacturer and then tested for movement class 200 % elongation as described in the Standard Specification For Precured Elastomeric Silicone Joint Sealants (5.1.1). The actual results are given in Table 1.

11.3 In one test series the three labs tested two sets of three specimens for movement and modulus according to 9.1 and 9.2.

11.4 In another test series the three labs tested two sets of three specimens for tear propagation according to 9.4.

11.5 Laboratory no. 3 tested one set of three specimens of a different product (Note 14) for movement and modulus according to 9.1 and 9.2. This product failed the movement class 200 %E.

11.6 Laboratory no. 3 tested one set of three specimens of a different product (Note 14) for tear propagation according to 9.4. This product failed the movement class 200 %E.

NOTE 14—Different product: precured part made from a commercially available acetoxycure silicone sealant.

11.7 Precision Data for:

11.7.1 Initial Tensile Load/Length of Specimen at 200 % Elongation (lbs/in.) Precision, characterized by repeatability, Sr, r, and reproducibility, SR, R has been determined for the materials to be:

Materials	Average	Sr	SR	r	R
A	7.557	0.893	1.072	2.499	3.002
B	product failed 200 % elongation test, no data available				

11.7.2 Tensile Load After 1 h Holding Time /Length of Specimen at 200 % Elongation (lbs/in.) Precision, characterized by repeatability, Sr, r, and reproducibility, SR, R has been determined for the materials to be:

Materials	Average	Sr	SR	r	R
A	5.243	0.518	0.518	1.451	1.451
B	product failed 200 % elongation test, no data available				

11.7.3 Ultimate Elongation (%) Precision, characterized by repeatability, Sr, r, and reproducibility, SR, R has been determined for the materials to be:

Materials	Average	Sr	SR	r	R
-----------	---------	----	----	---	---

TABLE 1 Precision and Bias Data from 3 Laboratories (Actual Test Results)

Tensile load over length of joint at 200 %E after 1 h	lbs/in.	5.62	4.63	5.09	5.63	5.00	5.15	fail
Loss of tensile load after 1 h holding time	%	37.63	33.81	29.98	29.60	21.98	28.00	n/a
Loss of adhesion (measured at deepest adhesion loss from the orig. bond-line (at 200 %E))	in.	none	none	none	none	none	none	n/a
Loss of cohesion (measured at deepest cohesion loss from the orig. bond-line (at 200 %E))	in.	none	none	none	none	none	none	n/a
Ultimate elongation (strain at peak load)	%	617.33	665.67	792.33	733.33	638.33	638.67	186.67
Peak tensile load over length of joint	lbs/in.	15.37	14.65	16.11	17.71	17.32	17.60	6.84
Describe kind of tear if any after 1 h holding time at 200 %E		partial tear	partial tear	partial tear	partial tear	partial tear	partial tear	tear

	A	680.889	83.168	103.837	232.871	290.743	Materials	Average	Sr	SR	r	R
A							A	16.629	1.042	1.533	2.916	4.293
B	186.67		product failed 200 % elongation test				B	6.84	product failed 200 % elongation test			

11.7.4 *Peak Tensile Load/Length of Specimen at Break (lbs/in.) Precision*, characterized by repeatability, Sr, r, and reproducibility, SR, R has been determined for the materials to be:

11.7.5 This precision statement is provisional. Within five years, additional data will be obtained and processed which does meet the requirements of Practice E 691.

*ASTM International takes no position respecting the validity of any patent rights asserted in connection with any item mentioned in this standard. Users of this standard are expressly advised that determination of the validity of any such patent rights, and the risk of infringement of such rights, are entirely their own responsibility.*

*This standard is subject to revision at any time by the responsible technical committee and must be reviewed every five years and if not revised, either reapproved or withdrawn. Your comments are invited either for revision of this standard or for additional standards and should be addressed to ASTM International Headquarters. Your comments will receive careful consideration at a meeting of the responsible technical committee, which you may attend. If you feel that your comments have not received a fair hearing you should make your views known to the ASTM Committee on Standards, at the address shown below.*

*This standard is copyrighted by ASTM International, 100 Barr Harbor Drive, PO Box C700, West Conshohocken, PA 19428-2959, United States. Individual reprints (single or multiple copies) of this standard may be obtained by contacting ASTM at the above address or at 610-832-9585 (phone), 610-832-9555 (fax), or service@astm.org (e-mail); or through the ASTM website (www.astm.org).*