



Designation: C 717 – 03

Standard Terminology of Building Seals and Sealants¹

This standard is issued under the fixed designation C 717; the number immediately following the designation indicates the year of original adoption or, in the case of revision, the year of last revision. A number in parentheses indicates the year of last reapproval. A superscript epsilon (ϵ) indicates an editorial change since the last revision or reapproval.

1. Scope

1.1 This standard covers terms, related standard definitions, and descriptions of terms used or likely to be used in standard test methods, specifications, guides, and practices (related to building seals and sealants) consistent with the scope and areas of interest of ASTM Committee C24.

1.2 Definitions and descriptions of terms are written to ensure that building seals and sealants standards are properly understood and interpreted.

2. Referenced Documents

2.1 ASTM Standards:

- C 509 Specification for Elastomeric Cellular Preformed Gasket and Sealing Material²
- C 542 Specification for Lock-Strip Gaskets²
- C 716 Specification for Installing Lock-Strip Gaskets and Infill Glazing Materials²
- C 790 Guide for Use of Latex Sealants²
- C 797 Practices and Terminology for Use of Oil- and Resin-Based Putty and Glazing Compounds²
- C 898 Guide for Use of High Solids Content, Cold Liquid-Applied Elastomeric Waterproofing Membrane with Separate Wearing Course²
- C 957 Specification for High-Solids Content, Cold Liquid-Applied Elastomeric Waterproofing Membrane with Integral Wearing Surface²
- C 961 Test Method for Lap Shear Strength for Hot-Applied Sealants²
- C 964 Guide for Lock-Strip Gasket Glazing²
- C 981 Guide for Design of Built-Up Bituminous Membrane Waterproofing Systems for Building Decks²
- C 1021 Practice for Laboratories Engaged in the Testing of Building Sealants²
- C 1127 Guide for Use of High Solids Content, Cold Liquid-Applied Elastomeric Waterproofing Membrane with an Integral Wearing Surface²

- C 1193 Guide for Use of Joint Sealants²
- D 883 Terminology Relating to Plastics³
- D 1079 Terminology Relating to Roofing, Waterproofing, and Bituminous Material⁴
- D 1565 Specification for Flexible Cellular Materials—Vinyl Chloride Polymers and Copolymers (Open-Cell Foam)³
- D 1566 Terminology Relating to Rubber⁵
- D 2102 Test Method for Shrinkage of Textile Fibers (Bundle Test)⁶
- E 631 Terminology of Building Constructions⁷
- 2.2 *ACI (American Concrete Institute) Standard:*
 - 301-72 (1975) Specifications to Structural Concrete for Buildings⁸

3. Significance and Use

3.1 Definitions:

3.1.1 Terms and their related standard definitions in Section 4 are intended for use uniformly and consistently in all building seals and sealants test methods, specifications, guides, and practices. The purpose of such use is to promote a clear understanding and interpretation of the standards in which they are used.

3.1.2 Definitions of terms are written in the broadest sense possible, consistent with the intended meaning. Definitions have not been limited to a specific technical field when they can have a multi-field application.

3.1.3 The definition of a term that can have different meanings in different technical fields is preceded by a phrase limiting it to the specific field intended, that is, “in building construction.”

3.2 Description of Terms:

3.2.1 Descriptions of Terms are special purpose definitions intended to provide a precise understanding and interpretation of the seals and sealants standards in which they are used.

3.2.2 A specific description of a term is applicable to the standard or standards in which the term is described and used.

¹ This terminology is under the jurisdiction of ASTM Committee C24 on Building Seals and Sealants and is the direct responsibility of Subcommittee C24.01 on Terminology of Building Seals and Sealants.

The boldface designations refer to the original source of the definition and the ASTM Technical Committee having jurisdiction.

Current edition approved Feb. 10, 2003. Published April 2003. Originally approved in 1972. Last previous edition approved in 2002 as C 717 – 02.

² *Annual Book of ASTM Standards*, Vol 04.07.

³ *Annual Book of ASTM Standards*, Vol 08.01.

⁴ *Annual Book of ASTM Standards*, Vol 04.04.

⁵ *Annual Book of ASTM Standards*, Vol 09.01.

⁶ *Annual Book of ASTM Standards*, Vol 07.01.

⁷ *Annual Book of ASTM Standards*, Vol 04.11.

⁸ Available from American Concrete Institute, P.O. Box 19150 Redford Station, Detroit, MI 48219.

3.2.3 Each standard in which a term is used, in a specially defined manner, should list the term and its description under the subheading, descriptions of terms.

4. Terminology

4.1 *Terms and Definitions:*

adhesive failure, n—in building construction, failure of the bond between the sealant, adhesive, or coating and the substrate surface.

back bedding, n—See **bedding**.

back putty, n—See **bedding**.

back-up material—See **sealant backing**.

band aid sealant joint, n—Use **bridge sealant joint** (preferred term).

bead, n—in building construction, in sealants and glazing, a strip of applied sealant, glazing compound, or putty.

bed, v—in building construction in glazing, to apply a bead of

sealant between a lite of glass or a panel and the stationary stops or sight bars of the sash or frame.

bed, n—See **bedding**.

bedding, n—in building construction in glazing, a bead of sealant applied between a lite of glass or a panel and the stationary stop or sight bar of the sash or frame. It is usually the first bead to be applied when setting glass or panels.

bicellular sealant backing, n—a flexible and very compressible extruded shape (usually cylindrical), with a surface skin, that is composed of both open and closed cell material.

bite, n—in building construction in glazing, the effective structural contact dimension of a structural sealant. (See Fig. 1 and Fig. 2.)

bloom, n—in building construction, a substance formed by blooming.

blooming, v—in building construction, movement or diffusion of a component such as a plasticizer, monomer, unreacted

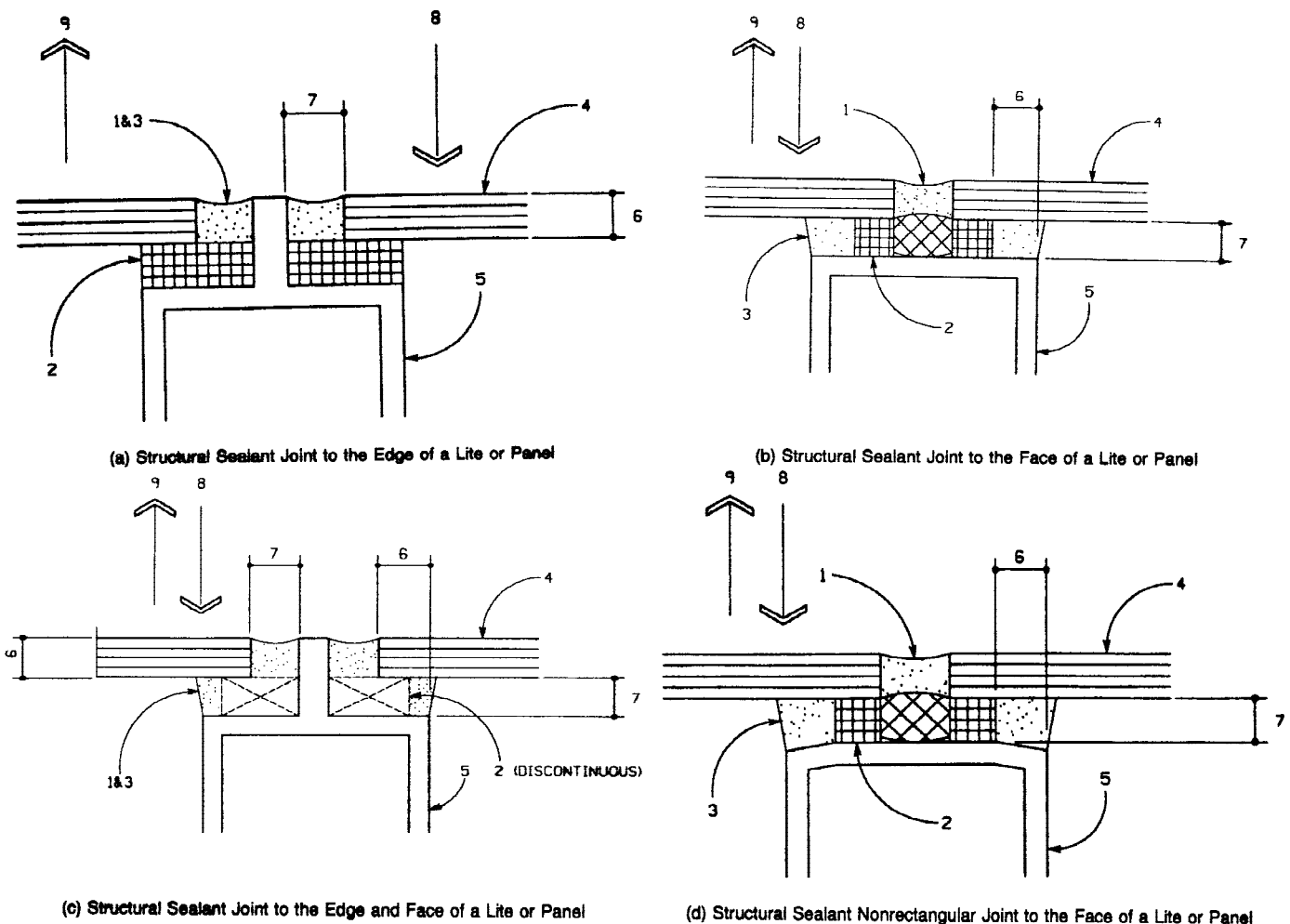

LEGEND

- (1) Weather seal
- (2) Spacer
- (3) Structural Sealant
- (4) Glass Lite or Panel
- (5) Metal Framing System
- (6) Bite (B)
- (7) Thickness (T)
- (8) Positive Lateral Load
- (9) Negative Lateral Load
- (10) Movement Due to Lateral Load
- (11) Sealant in Compression Due to Lateral Load
- (12) Sealant in Tension and Shear Due to Lateral Load

FIG. 1 Typical Structural Sealant Joint Configurations

ASTM C 717 - 03

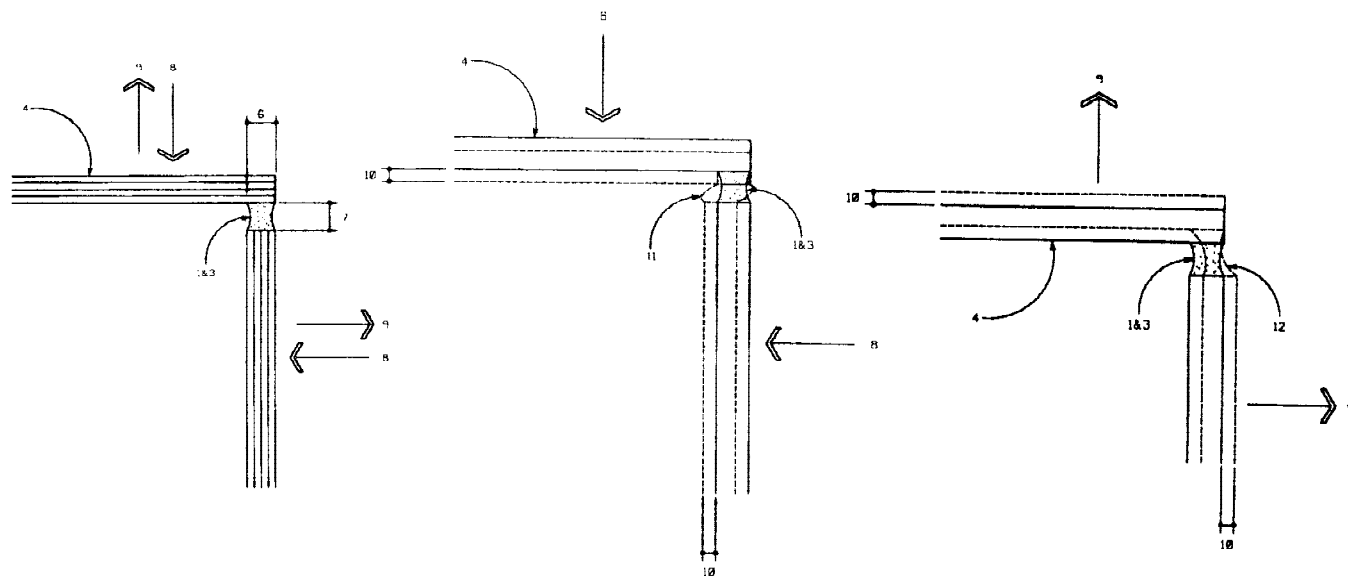

(a) Vertical Corner With One Lite or Panel Structurally Sealed to the Other

(b) Positive Applied Lateral Load

(c) Negative Applied Lateral Load

FIG. 2 Applied Load Transfer at a Vertical Corner Structural Sealant Joint (see Fig. 1 for Legend)

polymer or other formulation ingredient to a sealant, coating, or membrane surface.

bond breaker—*in building construction*, a material to prevent adhesion at a designated interface.

bridge sealant joint, n—*in building construction*, a joint where sealant is applied over the joint to the face of substrates that are in approximately the same plane (see Fig. 3).

DISCUSSION—Not to be confused with joints in bridges.

building seal—See **seal**.

butt glazing, n—*in building construction*, a glazing system wherein butt joints are formed between lites and filled with a glazing sealant.

butt joint, n—See **butt sealant joint**. (See Fig. 4.)

butt sealant joint, n—*in building construction*, a joint where sealant is applied within the joint between approximately parallel substrate surfaces that are face-to-edge or edge-to-edge. (See Fig. 4.)

caulk, v—*in building construction*, to install or apply a sealant across or into a joint, crack, or crevice.

caulk, n—See **sealant**.

caulking, n—See **sealant**.

caulking compound, n—See **sealant**.

cell, n—a single small cavity surrounded partially or completely by walls. **D 1566; D-11**

cellular material, n—a generic term for materials containing many cells (either open, closed, or both) dispersed through the mass. **D 1565; D1566; D-11**

chalk, n—*in building construction*, a powder formed by chalking

DISCUSSION—The powder is not necessarily white.

chalking, v—*in building construction*, formation of a powder on the surface of a sealant, coating, or membrane that is caused by the disintegration of the polymer or binding

FIGURE LEGEND

- A SEALANT
- B SEALANT BACKING
- C BOND BREAKER
- D JOINT
- E SUBSTRATE FACE
- F SUBSTRATE EDGE

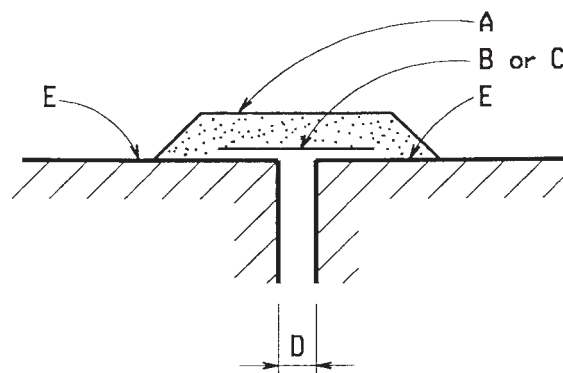
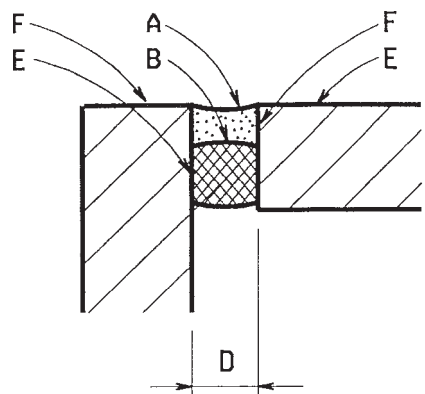

FIG. 3 Bridge Sealant Joint

medium due to weathering.

DISCUSSION—Chalk on a light color sealant is often white, however a darker color can also exhibit chalking.

closed cell, n—a cell totally enclosed by its walls and hence not interconnecting with other cells. **D 883; D-20**



a. face to edge

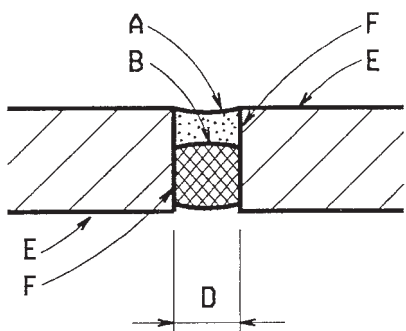

b. edge to edge

- A—Sealant
- B—Sealant backing
- C—Bond breaker
- D—Joint
- E—Substrate face
- F—Substrate edge

FIG. 4 Butt Sealant Joint

closed cell material, *n*—a cellular material in which substantially all cells in the mass are closed cells.

closed cell sealant backing, *n*—*in building construction*, a flexible and somewhat compressible extruded shape (usually cylindrical), with a surface skin, that is composed of closed cell material.

cohesive failure, *n*—*in building construction*, failure characterized by rupture within the sealant, adhesive, or coating.

cold joint, *n*—a plane of weakness in concrete caused by an interruption or delay in the placing operation, which permits the first batch to start setting before the next batch is placed, resulting in little or no bond between the two batches.

compatibility, *n*—*in building construction*, the capability of two or more materials to be placed in contact or close proximity with one another and each material maintaining its usual physical or chemical properties, or both.

compatible materials, *n*—*in building construction*, compounds or substances that can exist in close proximity to one another without detrimental effects on either.

compound, *n*—an intimate mixture of all the ingredients necessary for a finished material or product.

compression gasket, *n*—a gasket designed to be used under compression.

compression glazing, *n*—see **compression glazing system**.

compression glazing, *v*—*in building construction*, the act of installing components into a compression glazing system.

compression glazing system, *n*—*in building construction*, gasket(s) or a combination of sealant(s) and gasket(s) used to provide weather-tightness by way of continuous pressure on the components in the joint.

compression seal, *n*—a seal which is attained by a compressive force on the sealing material.

construction joint, *n*—*in building construction*, a formed or assembled joint at a predetermined location where two successive placements (“lifts”) of concrete meet.

DISCUSSION—Frequently a keyway or reinforcement is placed across the joint. With proper design, this joint may also function as a control or an isolation joint.

control joint, *n*—*in building construction*, a formed, sawed, tooled, or assembled joint acting to regulate the location and degree of cracking and separation resulting from the dimensional change of different elements of a structure.

DISCUSSION—The joint is usually installed in concrete and concrete masonry construction to induce controlled cracking at preselected locations or where a concentration of stresses is expected.

crazed, *adj*—*in building construction*, having a random network of cracks in a sealant, coating, or membrane surface which do not penetrate through the body of the material.

crazing, *v*—*in building construction*, the formation of a network of random surface cracks in a sealant, coating, or membrane.

creep, *n*—the time dependent part of a strain resulting from stress.

D 1079; D-8

cure, *v*—*in building construction*, to attain the intended performance properties of a compound by means of evaporation, chemical reaction, heat, radiation, or combinations thereof.

cure, *n*—*in building construction*, the process by which a compound attains its intended performance properties by means of evaporation, chemical reaction, heat, radiation, or combinations thereof.

cured, *adj*—*in building construction*, pertaining to the state of a compound that has attained its intended performance properties by means of evaporation, chemical reaction, heat, radiation, or combinations thereof.

dense rubber, *n*—*in building construction*, a solid rubber material substantially free of cells or porosity.

dirt pick-up, *n*—*in building construction*, soiling caused by a foreign material other than micro-organism growth that is deposited on, adhered to, or embedded into a sealant, coating, or membrane.

DISCUSSION—Micro-organism growth can produce a similar appearance.

dry-film thickness, *n*—the thickness of a cured film, coating, or membrane.

durability, *n*—*in building construction*, a general term for

resistance to deleterious change of an installed sealant, coating or membrane.

DISCUSSION—Durability describes the ability of a sealant, coating or membrane to maintain the required properties for its intended service. Durability is measured by the length of time that a sealant, coating, or membrane can maintain its functional characteristics in use. This time will vary depending on the environment and use of the sealant, coating, or membrane (for example, outdoor vs. indoor use).

durability limit, n—see the preferred term, **service life**.

edge spacer, n—in building construction in glazing, a spacer placed to prevent edge contact and to position laterally a pane of glass or a panel within the supporting frame.

elastomer, n—a macromolecular material that returns rapidly to approximately its original dimensions and shape after substantial deformation by a weak force and release of the force.

DISCUSSION—a) Elastomers are divided into two major polymer systems—thermoset and thermoplastic. b) In standards for rubber, the word elastomer is not to be used interchangeably for the term “rubber”.

D 1566; D-11

elastomeric, adj—having the characteristics of an elastomer.

elongation, n—extension produced by a tensile stress.

D 1566; D-11

expanded rubber, n—in building construction, an elastomeric closed-cell material made by incorporating a gas-producing ingredient into a rubber compound that decomposes during vulcanization, producing gas bubbles that expand the compound; the bubbles are predominately non-interconnecting.

expansion joint, n—in building construction, a formed or assembled joint at a predetermined location, which prevent the transfer of forces across the joint as a result of movement or dimensional change of different elements of a structure or building.

expansion joint seal, n—in building construction, a seal or sealant system that provides an elastic, compressible, or flexible barrier to the passage of gases, liquids, or solids.

face glazing, n—the method of glazing in which a rabbeted glazing recess, with no removable stop, is used and a triangular bead of compound is applied to the face of the lite and extended onto the recess.

fillet bead joint, n—Use **fillet sealant joint** (preferred term). (See Fig. 5.)

fillet sealant joint, n—in building construction, a joint where sealant is applied over the joint to the face of substrates that are approximately perpendicular to each other (see Fig. 5).

flow, v—in building construction, the deformation of a tape sealant under stress.

fluid migration, n—in building construction, accumulation of a fluid from a sealant, coating, or membrane on or in an adjacent material.

DISCUSSION—Migration of a non-fluid component can also occur.

four-side structural sealant glazing, n—in building construction, a glazing system wherein all sides of a rectangular-shaped lite or panel are structural sealant glazed.

gasket, n—any preformed, deformable device designed to be placed between two adjoining parts to provide a seal.

glazing, v—in building construction, the installation of glass or

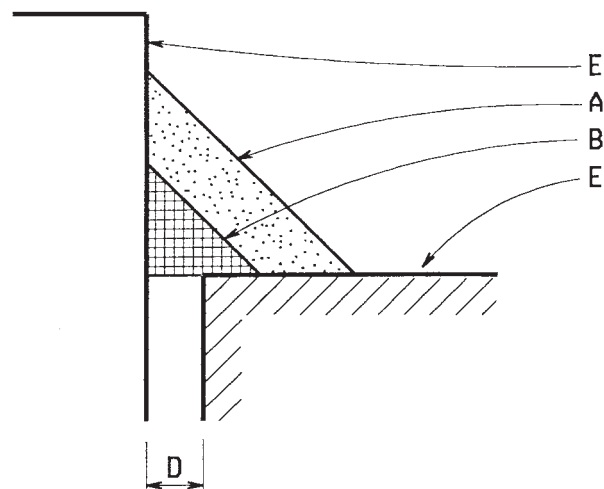
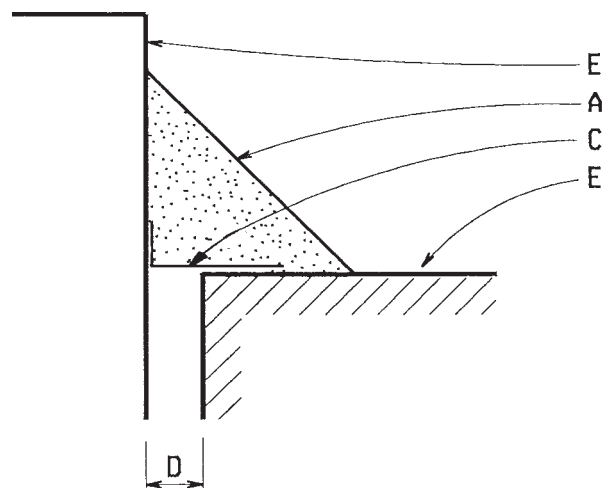

- A—Sealant
- B—Sealant backing
- C—Bond breaker
- D—Joint
- E—Substrate face
- F—Substrate edge

FIG. 5 Fillet Sealant Joints

other materials in prepared openings.

glazing compound, n—in building construction in glazing, a putty material composed primarily of oil- or resin-based ingredients used for sealing window glass in frames.

DISCUSSION—Historically these compounds cure primarily through solvent evaporation, oxidation or both. Compounds other than oil- or resin-based can be used for glazing, though they may not have a putty-like consistency.

glazing, construction site, n—in building construction, the installation of glass or panels into a metal framing system, at a construction site, under generally uncontrolled environmental conditions.

glazing, factory, n—See **glazing, shop**.

glazing, field, n—See **glazing, construction site**.

glazing, shop, n—*in building construction*, the installation of glass or panels into a metal framing system under controlled environmental conditions.

DISCUSSION—Shop glazing typically occurs at a location remote to a construction site. However, shop glazing can be performed at the construction site if acceptable to the code authority and provided appropriate management controls and environmental conditions are maintained.

gun-grade, n—*in building construction*, a material of a suitable viscosity to extrude through the nozzle of a hand- or power-operated device.

hardness, n—the resistance to indentation as measured under specified conditions. **D 1566; D-11**

hydrostatic pressure, n—a state of stress in which all the principal stresses are equal (and there is no shear stress), as in a liquid at rest; the product of the unit weight of the liquid and the difference in elevation between the given point and the free liquid elevation.

isolation joint, n—*in building construction*, a formed or assembled joint specifically intended to separate and prevent the bonding of one element of a structure to another and having little or no transference of movement or vibration across the joint.

joint, n—*in building construction*, the space or opening between two or more adjoining surfaces.

joint backing—See **sealant backing**.

joint filler, n—a compressible material used in a partial or totally filled expansion, control, or isolation joint by its permanent placement in or between building materials such as concrete or masonry during construction; sometimes used as a sealant backing in a partially filled joint.

knife-grade, n—*in building construction*, a compound of such consistency that it is generally applied with a knife or spatula hand tool.

laitance, n—*in building construction*, a weak layer of cement and aggregate fines on a concrete surface that is usually caused by an overwet mixture, overworking the mixture, improper or excessive finishing, or combinations thereof.

lap sealant joint, n—*in building construction*, a joint where sealant is applied within the joint between approximately parallel substrates that are face-to-face (see Fig. 6).

latex foam rubber, n—*in building construction*, an elastomeric open-cell material made by whipping or stirring air or some other gas into rubber latex compound as it is gelled and before it is subsequently cured.

DISCUSSION—The word *latex* must be in front of foam rubber so this material will not be confused with a number of chemically blown, fine cell, elastomeric products, which sometimes are incorrectly called *foam rubber*.

lift, n—the concrete placed between two consecutive horizontal construction joints.

light, n—Use **lite** (preferred term).

lite, n—one piece of glazing (also spelled light), synonym: pane. **E 631**

lock-strip gasket, n—*in building construction*, a gasket in which sealing pressure is attained by inserting a keyed locking strip into a mating keyed groove in one face of the gasket.

modulus, n—as related to sealants used in building construction, the stress (force/unit area) at a corresponding strain (elongation) expressed as a percent of the original dimension.

DISCUSSION—When the stress to strain values are expressed as a ratio, this describes the slope of a line tangent to the given point on the stress-strain curve. This is the tangent modulus.

modulus, secant—slope of the line connecting the origin and a given point of the stress-strain curve.

modulus, tangent, n—the slope of the line touching (tangent to) the stress-strain curve at a given point on the curve.

muntin, n—a secondary intermediate member subdividing a glazed area.

necking, n—*in building construction*, the localized reduction in cross section that may occur in a material under stress. **D 883; D-20**

needle glazing—*in building construction*, the application of a small bead of a sealant at the sight line adhering to the sash and glass or panel by means of a nozzle with an orifice not exceeding 1/8 in. (3.18 mm) in diameter.

non-compression glazing, n—see **non-compression glazing system**.

non-compression glazing, v—*in building construction*, the act of installing components into a non-compression glazing system.

non-compression glazing system, n—*in building construction*, a sealant or combination of sealant(s) used to provide weather-tightness by way of the adhesive/cohesive characteristics of the components in the joint.

open cell, n—a cell not totally enclosed by its walls and hence interconnecting with other cells. **D 1566; D-11**

open cell material, n—a cellular material in which substantially all cells in the mass are open cells.

open cell sealant backing, n—*in building construction*, a flexible and very compressible fabricated shape (usually cylindrical), without a surface skin, that is composed of open cell material.

outgassing, n—the emission of occluded gasses from a material by vacuum, heat, or pressure.

DISCUSSION—As applied to sealant backing materials contained

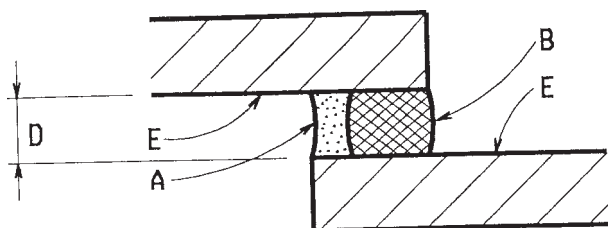

A—Sealant
B—Sealant backing
C—Bond breaker
D—Joint
E—Substrate face
F—Substrate edge

FIG. 6 Lap Sealant Joints

within a filled joint, outgassing may occur when it is compressed or punctured causing gas bubbles to form in the overlying sealant.

pane, n—See **lite**.

placement, n—the process of placing and consolidating concrete; a quantity of concrete placed and finished during a continuous operation; also inappropriately called pouring.

pot life—See **working life**.

premature deterioration, n—*in building construction*, significant deleterious change (to a degree that jeopardizes functionality) of an installed sealant, coating or membrane earlier than the product's claimed or reasonably expected service life.

primer—*in building construction*, a compatible coating designed to enhance adhesion.

putty, n—*in building construction*, a knife-grade compound generally used as a glazing compound or to fill cracks or holes.

rabbet, n—a two-sided, L-shaped, recess in a sash or frame designed to receive glazing.

DISCUSSION—Provides a fixed stop in the sash or frame.

reglet, n—a continuous groove, slot or recess within a building component surface which receives other components such as flashing, gaskets or anchors; a continuous prefabricated metal or plastic device containing a groove, slot or recess which can be cast into (as a form) or mounted onto a building component surface.

reinforced joint, n—a concrete joint bridged by reinforcing steel embedded in both joining parts.

reversion, n—*in building construction in joint sealing*, a loss of elastomeric properties and a decrease in durometer hardness of a seal or cured sealant following environmental exposure.

DISCUSSION—Softening and the ability to permanently reshape a seal or sealant usually characterizes reversion. Depending on a specific seal or sealant formulation, high heat, ultraviolet radiation, or moisture (as a liquid or vapor) may cause reversion acting either alone or in combination. The seal and sealant industry is not in agreement on reversion causes.

rundown, n—*in building construction*, bloom or fluid migration from a sealant, coating, or membrane that due to natural forces is carried down and accumulates on vertical and sloping surfaces.

DISCUSSION—Similar patterns of discoloration can be caused by other than blooming and fluid migration.

sag, n—*in building construction*, the gravity-induced downward flow of a sealant or glazing compound, resulting in an uneven thickness, when applied on a vertical surface.

seal, n—*in building construction*, a barrier against the passage of liquids, solids, or gases.

sealant—*in building construction*, a material that has the adhesive and cohesive properties to form a seal.

sealant, chemically curing, n—*in building construction*, a compound that cures primarily through chemical reaction.

sealant, emulsion—See **sealant, latex**.

sealant, hot-applied, n—*in building construction*, a compound that is applied in a molten state and cures primarily by

cooling to ambient temperatures.

DISCUSSION—A hot-applied sealant is sometimes called a hot-melt sealant.

sealant, latex, n—*in building construction*, a compound that cures primarily through water evaporation.

DISCUSSION—The terms latex sealant and emulsion sealant are sometimes used interchangeably.

sealant, non-sag, n—*in building construction*, a compound that exhibits little or no flow when applied in vertical or inverted joints.

sealant, precured, n—*in building construction*, a preformed, factory cured elastomeric material that when adhered to a joint forms a seal.

sealant, preshimmied, n—*in building construction*, a sealant having encapsulated therein solids or discrete particles that limit its deformation within a joint under compression.

DISCUSSION—The sealant may be in tape or bulk form. Encapsulated solids or particles may include such materials as continuous rods of resilient plastic or rubber, glass beads, or string, which act as shims or space fillers.

sealant, preshimmied tape, n—*in building construction*, a preshimmied sealant in tape sealant form.

DISCUSSION—The shim is usually a continuous plastic or rubber rod or discrete particles placed within the body of the tape sealant to regulate the compressibility of the tape sealant. See also **sealant, tape** and **sealant, preshimmied**.

sealant, self-leveling, n—*in building construction*, a compound that exhibits flow sufficient to seek gravitational leveling.

sealant, silicone, n—*in building construction*, a liquid-applied curing compound based on polymer(s) of polysiloxane structures.

sealant, solvent-release, n—*in building construction*, a compound that cures primarily through solvent evaporation.

sealant, structural, n—*in building construction*, a sealant capable of transferring dynamic or static (“live” or “dead,” or both) loads, or both, across joint members exposed to service environments typical for the structure involved.

sealant, tape, n—*in building construction*, a sealant having a preformed shape, and intended to be used in a joint initially under compression.

sealant backing—*in building construction*, a compressible material placed in a joint before applying a sealant.

DISCUSSION—The purpose of the sealant backing is to assist in providing the proper sealant configuration, to limit the depth of the sealant, and in some cases, to act as a bond breaker.

sealing material, n—See **seal**.

sealing tape—See **sealant, tape**.

secant modulus—See **modulus, secant**.

service life, n—*in building construction*, the period of time an installed sealant, coating, or membrane is reasonably expected to function successfully without replacement or significant repair, assuming reasonable or expected periodic maintenance is performed.

setting block, n—*in building construction in glazing*, a piece

of resilient material placed to support, to distribute the load, to prevent edge contact, and to align a pane of glass or a panel within its supporting frame.

shelf-life—*in building construction*, the maximum time packaged materials can be stored under specified conditions and still meet the performance requirements specified.

shim—See **shim spacer**; **spacer**.

shim spacer, *n*—*in building construction in glazing*, a spacer designed and placed to position the face surfaces of a pane of glass or a panel between the stops and to prevent glass or panel contact with the stops.

shrinkage—a decrease in length, area, or volume. **D 2102; D-13**

sight line—*in building construction in glazing*, the line of intersection of an opaque material with a transparent material.

skin, *n*—*in building construction*, a thin layer at the surface of a sealant, cellular rubber gasket, sealant backing, or joint filler that differs in physical properties from the material beneath it.

DISCUSSION—The skin generally decreases the degree of permeability to water or air, or both, through or into a cellular rubber gasket, sealant backing, or joint filler. On sealants, the skin generally offers reduced surface tack, resistance to dirt accumulation, a degree of resistance to mechanical surface deformation damage, and typically indicates the end of tooling time.

spacer, *n*—*in building construction in glazing*, a piece of resilient material placed to maintain space between a pane of glass or a panel and its supporting frame.

spall, *n*—a fragment or chip as from concrete, brick, stone or other similar materials.

spall, *v*—to break off fragments or chips, as from concrete, brick, stone or other similar materials, by water freezing within the material, corrosion expansion of embedded metal, movement pressures, or other physical or chemical processes.

spalling, *adj*—the development of spalls.

sponge rubber, *n*—*in building construction*, an elastomeric open-cell material made by incorporating a gas-producing ingredient into a rubber compound, which expands the rubber compound during vulcanization into a material containing cells that are predominately interconnecting.

standard conditions, *n*—*in building construction*, laboratory test conditions consisting of a relative humidity of $50 \pm 5\%$ at an air temperature of $23 \pm 1^\circ\text{C}$ ($73.4 \pm 2^\circ\text{F}$) at ambient atmospheric pressure.

DISCUSSION—The laboratory environment should be free from direct sun rays and the effects of vapors, gases, and other contaminants.

stop, *n*—*in building construction*, in sealants and glazing, a strip of metal, plastic, or wood used around the periphery of a lite of glass or a panel to secure it in place (also referred to improperly as a bead).

stopless glazing—See **structural sealant glazing**, the preferred term.

DISCUSSION—Inappropriately used to describe structural sealant glazing.

structural sealant glazing, *n*—*in building construction*, a

glazing system wherein a structural sealant is used to transfer loads between a lite or panel and a supporting framework, without mechanical fasteners or other methods of attachment.

substrate, *n*—*in building construction*, (1) a material upon which films, treatments, adhesives, sealants, membranes, and coatings are applied; (2) materials that are bonded or sealed together by adhesives or sealants.

tangent modulus—See **modulus, tangent**.

thermoplastic elastomer, *n*—a material having the general properties of an elastomer and capable of being repeatedly softened by heat and hardened to shape by cooling without significant degradation of the polymer system.

DISCUSSION—Thermoplastic elastomers have some of the properties of thermoset elastomers, but are typically more thermally and pressure sensitive and more sensitive to solvents.

thermoset elastomer, *n*—an elastomeric material that attains its intended properties by an irreversible cross-linking reaction caused by heat alone, heat with a cross-linking agent, chemical interaction, or by radiation; whereby after cross-linking, any reprocessing with heat and pressure will severely degrade the material.

DISCUSSION—Cross-linking renders the material substantially insoluble in organic solvents (can swell), less plastic, and with improved elastic and mechanical properties (compared to its uncured state) over an extended temperature range.

thickness, *n*—*in building construction in glazing*, the minimum structural sealant dimension between structurally bonded substrates (see Fig. 1 and Fig. 2).

DISCUSSION—When adhesion surfaces are not parallel the minimum dimension between those surfaces shall be used (see Fig. 1d).

tooling—*in building construction*, the act of compacting and contouring a sealant in a joint.

tooling time, *n*—*of a sealant*, the time interval after application of a one-component sealant or after mixing and application of multi-component sealant during which tooling is possible.

two-side structural sealant glazing, *n*—*in building construction*, a glazing system wherein two sides of a rectangular-shaped lite or panel, usually opposing, are structural sealant glazed.

unicellular rubber, *n*—See **expanded rubber**.

vulcanization, *n*—an irreversible chemical reaction during which a rubber compound's chemical structure is changed to make it less plastic, more resistant to solvents, and have improved physical and mechanical properties.

DISCUSSION—Generally, sulfur or other cross-linking agents, or both, are used. High energy radiation curing is a new and important innovation.

waterproofing, *n*—*in building construction*, treatment of a surface or structure to prevent the passage of liquid water under hydrostatic, dynamic, or static pressure.

weathering, *n*—*in building construction*, any change of an installed sealant, coating, or membrane due to the action of atmospheric elements.

DISCUSSION—Atmospheric elements include, among others, solar

radiation, temperature, temperature changes, moisture (solid, liquid, or vapor), wind, ozone, carbon dioxide, pollution, and freeze-thaw cycling.

weathering, *v*—*in building construction*, the exposure of an installed sealant, coating, or membrane due to atmospheric elements.

DISCUSSION—Atmospheric elements include, among others, solar radiation, temperature, temperature changes, moisture (solid, liquid, or vapor), wind, ozone, carbon dioxide, pollution, and freeze-thaw cycling.

weathertight, *adj*—*in building construction*, impermeable to the passage of air or water or both under certain conditions as determined by test.

weathertightness, *n*—*in building construction*, the degree of permeability to the passage of water or air or both under certain conditions as determined by test.

working life, *n*—*of a sealant*, the time interval after opening a container of a single component sealant, or after mixing the components of a multi-component sealant, during which application and tooling is possible.

DISCUSSION—Working life and pot life are equivalent terms applicable to multi-component sealants.

4.2 *Description of Terms:*

applicator—any device used to mechanically apply molten sealants that is capable of delivering the required volume at the specified application temperature. **C 961**

authority—the person (organization) authorizing the testing. **C 1021**

beveled bead—a bead of glazing compound having a sloped surface to drain water away from the glass or panel.

C 797

buttering—the application of a glazing compound to a flat contact surface of a member before placing that member in position, such as the buttering of a removable stop before fastening it in place. **C 797**

cellular, *adj*—having a composition of plastic or rubber with relative density decreased by the presence of cells disposed throughout its mass. In closed-cell materials, the cells are predominantly separate from each other. In open-cell materials, the cells are predominantly interconnected. **C 981**

channel—a three-sided, U-shaped recess in a sash or frame to receive a light of glass or a panel; may be formed between an integral and a removable stop or in “pocket” glazing, with no removable stop. **C 797**

channel glazing—the method of glazing in which lights or panels are set in a channel formed by two stops (see Fig. 7). **C 797**

clamping pressure—the pressure exerted by the lip of the lock-strip gasket on material installed in the channel, when the lock-strip is in place. **C 542; C716; C964**

clip—a wire spring device used to hold glass in a rabbeted metal sash for face-glazing. **C 797**

cold-applied—capable of being applied without heating as contrasted to hot-applied; cold-applied products are furnished in a liquid state, whereas hot-applied products are furnished as solids that must be heated to liquefy them. **C 898; C957; C1127**

compatible—nonstaining to substrate and sealant and nondetrimental to sealant performance. **C 962**

curing time—the period between application and the time when the material attains its intended physical properties.

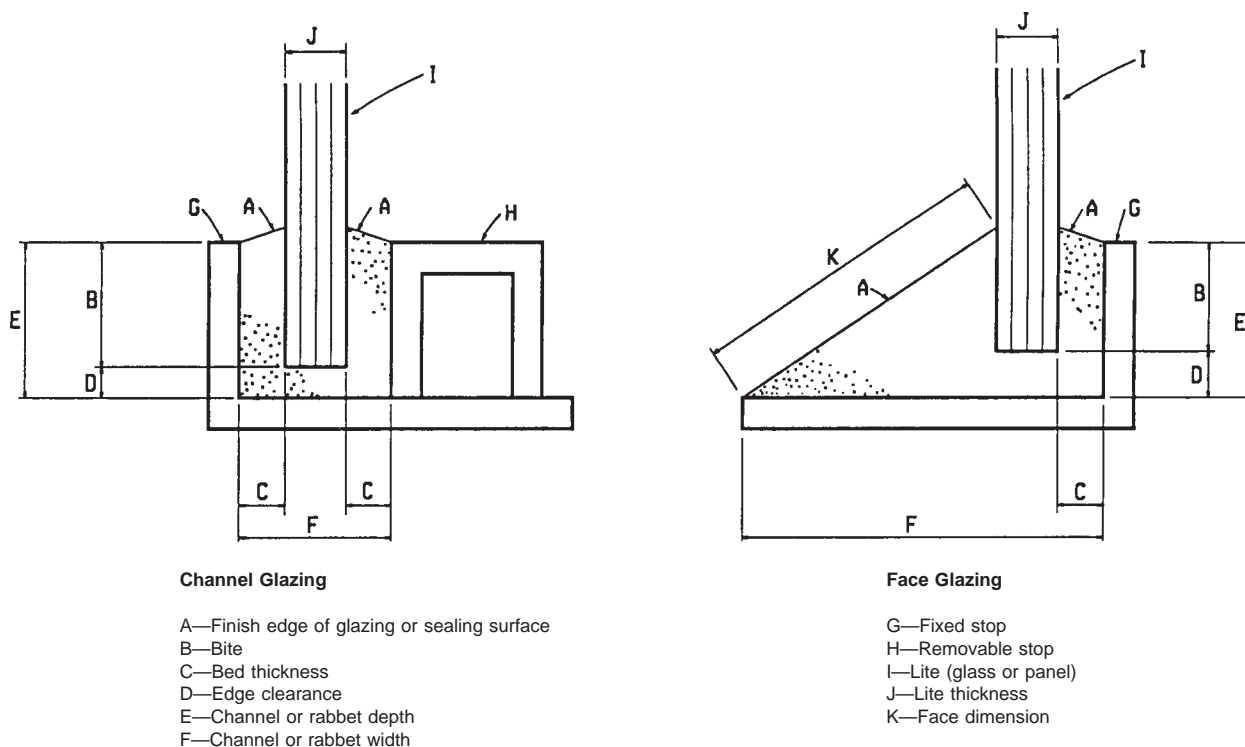

FIG. 7 Typical Glazing Profiles

C 898; C981; C1127

deck—the horizontal structural substrate supporting the plaza deck system. See also **structural slab**. **C 957; C981, C1127**

deflection—the deviation of a structural element from its original shape or plane due to physical loading, temperature changes or rotation of its supports. **C 898; C981; C1127**

drainage course—See **percolation layer** and Fig. 8. **C 898; C981**

dry occupancy—an occupied space below the plaza deck system in which the computed or anticipated relative humidity is below 30 %. **C 981**

durometer—(1) an instrument for measuring the hardness of rubber-like materials. (2) a term used to identify the relative hardness of rubber-like materials, for example “low durometer” (relatively soft) or “high durometer” (relatively hard). **C 542; C716; C964**

dynamic—exhibiting change or movement. **C 981**

edge clearance—the distance between the bottom of a channel of a lock-strip gasket and the edge of material installed in the channel. (See Fig. 9.) **C 542; C716; C964**

exterior glazed—glazed from the exterior of the building. **C 797**

exterior stop—a removable or integral stop on the outdoor side of glass or a panel. **C 797**

extrudability—force required to produce sealant flow through an orifice. **C 790**

filler strip—See **lock-strip**, the preferred term. **C 542; C716; C964**

finish—the exposed top surface of the plaza deck system, or traffic, or wearing surface. **C 981; C1127**

finish wearing surface—See *traffic surface*. **C 898**

flange—that part of a lock-strip gasket which extends to form one side of a channel (see Fig. 9). **C 542; C716; C 964**

flashing—a generic term describing the transitional area between the waterproofing membrane and surfaces above the wearing surface of the building deck; a terminal closure or barrier to prevent ingress of water into the system. **C 898; C981; C1127**

flexible foam—a preformed, cured, flexible, cellular material made from foamed rubber or plastic. **C 1193**

floated finish—a concrete finish provided by consolidating and leveling the concrete with only a power driver or hand float, or both. A floated finish is coarser than a troweled finish. For specifications, See ACI 301-72 (1975). **C 898; C981; C1127**

freeze-thaw cycle—the freezing and subsequent thawing of a material. **C 898; C981; C1127**

gasket glazing—a method of setting glass or panels in prepared openings, using a preformed gasket to obtain a weathertight seal. **C 509**

gasket, lock-strip, H-type—two channel recesses, of equal or unequal sizes, one on either side of a central web (see Fig. 9). **C 542**

gasket, lock-strip, reglet-type—a channel recess on the inner edge and a tongue, or spline, on the outer edge, the latter being designed for insertion in a reglet (see Fig. 9). **C 542**

gasket, structural—See **lock-strip gasket**, the preferred term. **C 542; C716; C964**

gasket, zipper—See **lock-strip gasket**, the preferred term. **C 542; C716; C964**

grout—concrete containing no coarse aggregates; a thin mortar. **C 898; C981; C1127**

heel bead—glazing compound applied at the base of a glazing channel, on the removable stop side, *after* setting glass or panel and before the removable stop is installed. **C 797**

H-gasket—See **gasket, lock-strip, H-type** and Fig. 7. **C 542; C716; C964**

hinge—the minimum thickness of gasket material between the channel recess and the lock-strip cavity; the plane at which bonding occurs when the flange is bent open to receive or release installed material. **C 542; C716; C964**

horizontal ladder gasket—a ladder gasket installed in a vertical plane in such a way that the intermediate cross members (muntins) are vertical members (see Fig. 10). **C 716; C964**

insulating concrete—a lightweight concrete made with lightweight coarse aggregate and having relatively low insulating

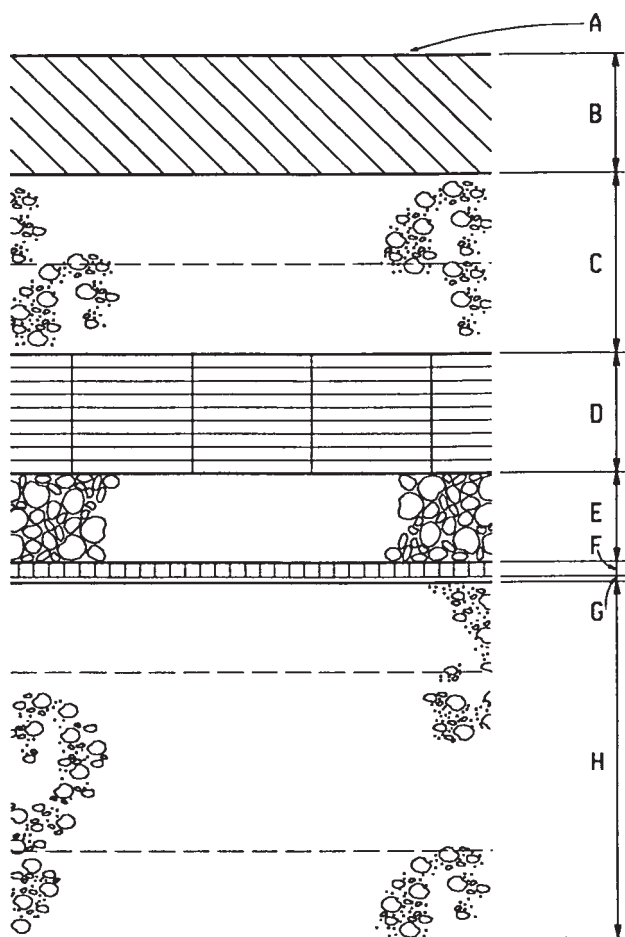

A—Wearing surface
B—Wearing course
C—Protection or working slab
D—Insulation
E—Drainage course
F—Protection course
G—Liquid-applied membrane
H—Structural slab over occupied space

FIG. 8 Basic Components of a Cold Liquid-Applied Elastomeric Membrane Waterproofing System With Separate Wearing Course

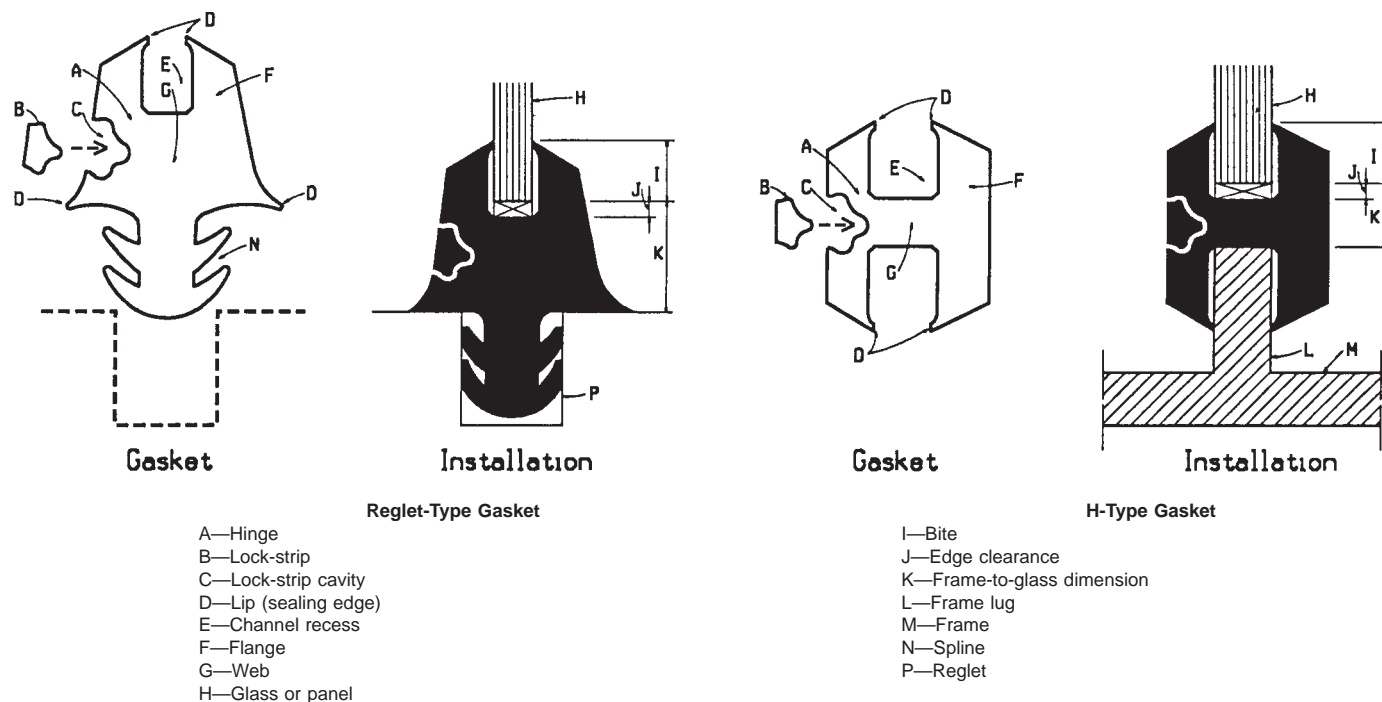

FIG. 9 Basic Lock Strip Gasket Glazing Profiles, Functional Principles, and Nomenclature

characteristics. **C 981**

interior glazed—glazed from the interior of the building. **C 797**

interior stop—a removable or integral stop on the indoor side of the glass or panel. **C 797**

joint width—See Fig. 9. **C 1193**

ladder gasket—a lock-strip gasket in the form of a subdivided frame having one or more integrally formed intermediate cross members (see Fig. 10). **C 542; C716; C964**

lip—the inner face of the tip of a flange on a lock-strip gasket (see Fig. 9). **C 542; C716; C964**

lip pressure—the pressure exerted by the lip of a lock-strip gasket on material installed in the channel, when the lock-strip is in place. **C 542; C716; C964**

lip seal pressure—the lip pressure required to effect a seal against the passage of water and air. **C 542**

lock strip or locking strip—the strip that is designed to be inserted in the lock-strip cavity to force the lips against material placed in the channel (see Fig. 9). **C 542; C716; C964**

lock-strip cavity—the groove in the face of a lock-strip gasket designed to receive and retain the lock-strip (see Fig. 9). **C 542; C716; C964**

percolation layer (drainage course)—a layer of washed gravel or of a manufactured drainage media that allows water to filter through to the drain (see Fig. 8). **C 898; C981**

ply—a single layer of membrane reinforcement in the bituminous membrane waterproofing system. **C 981**

point—a thin, flat, triangular or diamond-shaped piece of zinc used to hold glass in wood sash by driving it into the wood. **C 797**

preformed gasket—an elastomeric compound molded in the

form of a continuous strip, channel, or other shape, for use in filling joints and providing weathertight seals in glazing or between building components. **C 509**

preformed sealant backing—See Fig. 11. **C 1193**

preparatory coat—an initial coat of the liquid-applied membrane which is applied at cracks, joints, or terminal points to provide reinforcement to the membrane at these critical areas. **C 1127**

protection board—See **protection course** (see Fig. 6). **C 898; C981**

protection course—semi-rigid sheet material placed on top of the waterproofing membrane to protect it against damage during subsequent construction and to provide a protective barrier against compressive and shearing forces induced by materials placed above it (see Fig. 8). **C 898**

raggle—same as reglet. **C 981**

reglet gasket—See **gasket, lock-strip, reglet type**. **C 542**

scaling—same as spalling. **C 981**

screw-on-bead or stop—stop, molding, or bead secured in place by screws or nails. **C 797**

sealant backing depth—See Fig. 9. **C 1193**

sealant contact depth—See Fig. 9. **C 1193**

sealant depth—See Fig. 9. **C 1193**

sealant recess depth—See Fig. 9. **C 1193**

sealant width—See Fig. 9. **C 1193**

specified temperature—application temperature specified by the sealant manufacturer. **C 961**

spline or tongue—that part of a reglet-type lock-strip gasket which is designed to be installed in a reglet in supporting material (see Fig. 9). **C 542; C716; C964**

static—exhibiting little or no change or movement. **C 981**

stop, removable—a removable molding or bead used around the periphery of a light of glass or a panel to secure it in

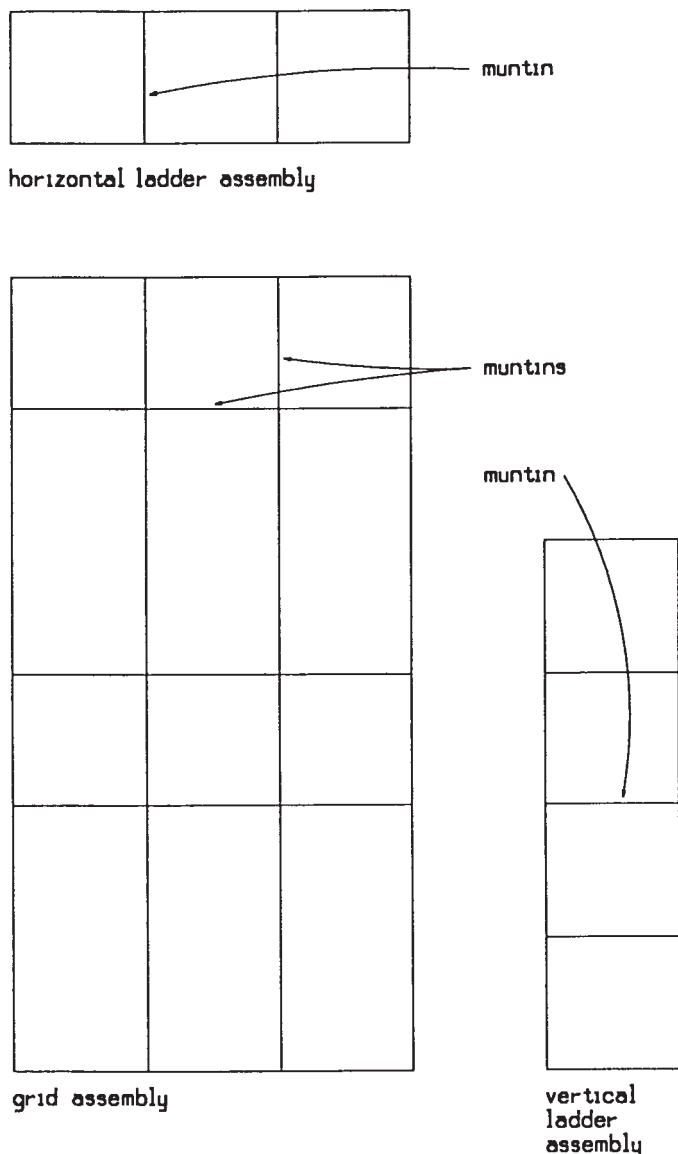

FIG. 10 Gasket Systems

place. C 797
stop, stationary or integral—the face of a rabbet or fin formed as an integral part of a frame or sash and against which glass or a panel is set. C 797
structural gasket—See *lock-strip gasket*, the preferred term. C 964

structural slab—a horizontal, supporting, cast-in-place, concrete building deck (see Fig. 8). C 898; C981; C1127
supported gasket member—a gasket member held in place by a supporting frame member. C 716; C964
tack—sticky or adhesive quality of the surface of applied sealant. C 790
technician—an employee of the testing laboratory assigned to perform the actual operations of testing. C 1021
testing laboratory—a qualified organization authorized to test building sealants for compliance with specified standards. C 1021
toe bead—a bead of glazing or sealing compound applied at the base of a glazing channel, on the integral stop side of the glass, *before* setting the glass or panel, to prevent leakage past the stop (see also *heel bead*). C 797
tooling depth—See Fig. 9.
traffic surface—a surface exposed to traffic, either pedestrian or vehicular, also described as finish wearing surface. C 898; C1127
troweled finish—a concrete finish provided by smoothing the surface with power driven or hand trowels or both, after the float finishing operation. A troweled finish is smoother than the floated finish. For specifications, see ACI 301-72 (1975). C 898; C1127
united millimetres (or united inches)—the sum of the dimensions in millimetres (or inches) of the length and width of a light of glass or panel. C 797
unsupported gasket member—a gasket member joining infill materials without being held in place by a supporting frame member. C 716; C964
vertical ladder gasket—a ladder gasket installed in a vertical plane in such a way that the intermediate cross members (muntins) are horizontal members (see Fig. 10). C 716; C964
wearing surface—See **traffic surface**. C 898; C1127
weathertight—preventing passage of liquid water and gas. C 1193
web—that part of an H-type lock-strip gasket which extends between the flanges, forming two channels and that part of a reglet-type lock-strip gasket which extends between the flanges and spline (see Fig. 9). C 542; C716; C964
wet-film gage—a gage for measuring the thickness of a wet film. C 898; C1127
wet-film thickness—the thickness of a liquid coating as it is applied. C 898; C957; C1127
zipper gasket—See **lock-strip gasket**, the preferred term. C 964

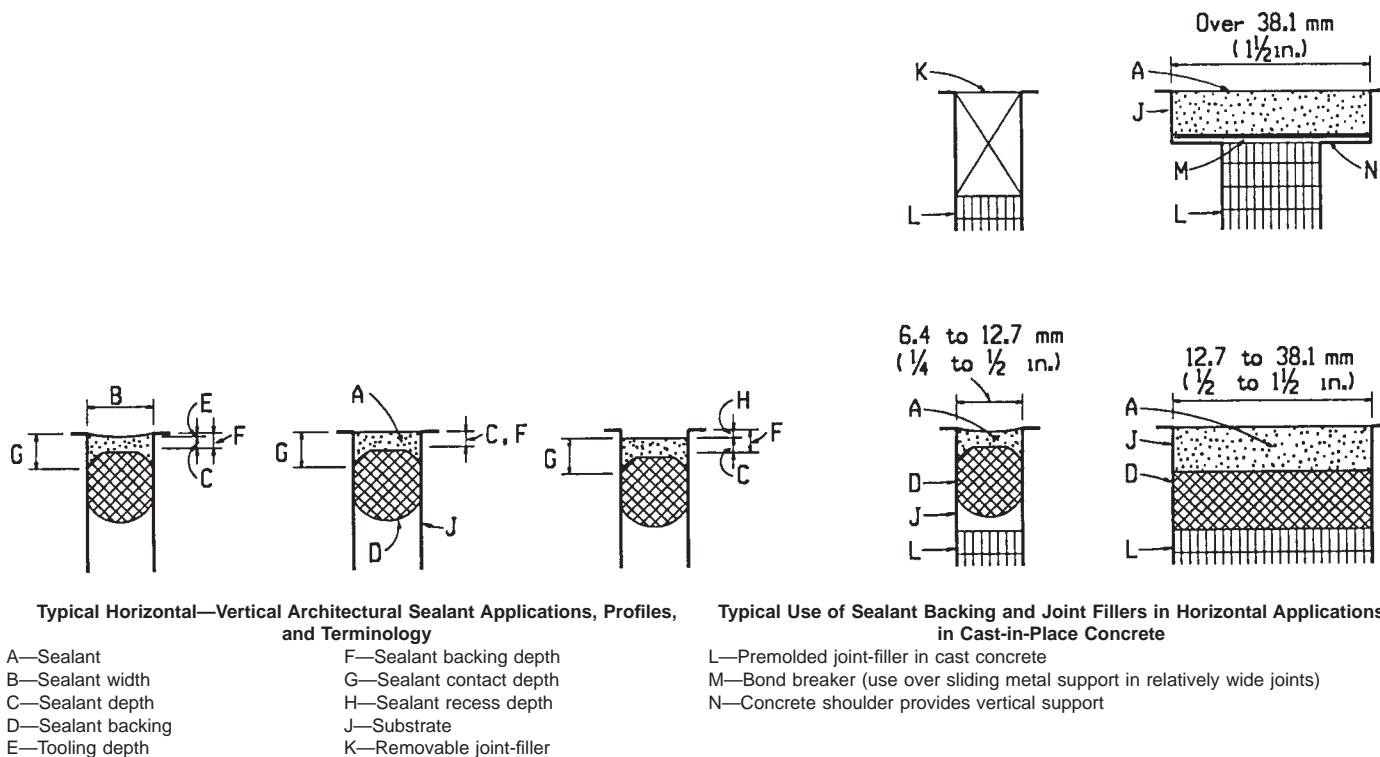

FIG. 11 Sealant, Backing, and Filler Profiles

ASTM International takes no position respecting the validity of any patent rights asserted in connection with any item mentioned in this standard. Users of this standard are expressly advised that determination of the validity of any such patent rights, and the risk of infringement of such rights, are entirely their own responsibility.

This standard is subject to revision at any time by the responsible technical committee and must be reviewed every five years and if not revised, either reapproved or withdrawn. Your comments are invited either for revision of this standard or for additional standards and should be addressed to ASTM International Headquarters. Your comments will receive careful consideration at a meeting of the responsible technical committee, which you may attend. If you feel that your comments have not received a fair hearing you should make your views known to the ASTM Committee on Standards, at the address shown below.

This standard is copyrighted by ASTM International, 100 Barr Harbor Drive, PO Box C700, West Conshohocken, PA 19428-2959, United States. Individual reprints (single or multiple copies) of this standard may be obtained by contacting ASTM at the above address or at 610-832-9585 (phone), 610-832-9555 (fax), or service@astm.org (e-mail); or through the ASTM website (www.astm.org).