



Standard Guide for Lock-Strip Gasket Glazing¹

This standard is issued under the fixed designation C 964; the number immediately following the designation indicates the year of original adoption or, in the case of revision, the year of last revision. A number in parentheses indicates the year of last reapproval. A superscript epsilon (ϵ) indicates an editorial change since the last revision or reapproval.

1. Scope

1.1 This guide covers the use of lock-strip gaskets in compliance with Specification C 542 in walls of buildings not over 15° from a vertical plane. The prime performance considerations are weathertightness against air and water infiltration, and structural integrity under wind loads. Included are terminology, design considerations, and fabrication tolerances when using lock-strip gaskets in glazing applications.

1.2 The values stated in inch-pound units are to be regarded as the standard. The SI units in parentheses are for information only.

1.3 *This standard does not purport to address all of the safety concerns, if any, associated with its use. It is the responsibility of the user of this standard to establish appropriate safety and health practices and determine the applicability of regulatory limitations prior to use.*

2. Referenced Documents

2.1 ASTM Standards:

- C 542 Specification for Lock-Strip Gaskets²
- C 716 Specification for Installing Lock-Strip Gaskets and Infill Glazing Materials²
- C 717 Terminology of Building Seals and Sealants²
- C 864 Specification for Dense Elastomeric Compression Seal Gaskets, Setting Blocks, and Spacers²
- C 963 Specification for Packaging, Identification, Shipment, and Storage of Lock-Strip Gaskets²
- C 1036 Specification for Flat Glass³
- D 1566 Terminology Relating to Rubber⁴
- E 283 Test Method for Determining the Rate of Air Leakage Through Exterior Windows, Curtain Walls, and Doors Under Specified Pressure Differences Across the Specimen⁵
- E 330 Test Method for Structural Performance of Exterior Windows, Curtain Walls, and Doors by Uniform Static Air Pressure Difference⁵

¹ This guide is under the jurisdiction of ASTM Committee C-24 on Building Seals and Sealants and is the direct responsibility of Subcommittee C24.73 on Compression Seal and Lock-Strip Gaskets.

Current edition approved Sept. 8, 1988. Published March 1989. Originally published as C 964 – 81. Last previous edition C 964 – 87.

² *Annual Book of ASTM Standards*, Vol 04.07.

³ *Annual Book of ASTM Standards*, Vol 15.02.

⁴ *Annual Book of ASTM Standards*, Vol 09.01.

⁵ *Annual Book of ASTM Standards*, Vol 04.11.

E 331 Test Method for Water Penetration of Exterior Windows, Curtain Walls, and Doors by Uniform Static Air Pressure Difference⁵

3. Terminology

3.1 *Definitions*—Refer to Terminology C 717 for definitions of the following terms used in this guide: bite; compound; edge spacer; elastomer; elastomeric; gasket; glazing; hardness; joint; lock-strip gasket; open cell; seal; sealant; setting block; and spacer. Additional elastomeric terms can be found in Terminology D 1566.

3.2 *Definitions of Terms Specific to This Standard:*

3.2.1 *clamping pressure*—the pressure exerted by the lip of a lock-strip gasket on material installed in the channel when the lock-strip is in place.

3.2.2 *durometer*—(1) an instrument for measuring the hardness of rubber-like materials. (2) a term used to identify the relative hardness of rubber-like materials, for example, “low durometer” (relatively soft) or “high durometer” (relatively hard).

3.2.3 *edge clearance*—the distance between the bottom of a channel of a lock-strip gasket and the edge of material installed in the channel (see Figs. 1 and 2).

3.2.4 *elongation*—increase in length, expressed as a percent of the original length.

3.2.5 *filler strip*—see *lock-strip*, the preferred term.

3.2.6 *flange*—that part of a lock-strip gasket that extends to form one side of a channel (see Figs. 1 and 2).

3.2.7 *H-gasket*—See *lock-strip gasket*, and Fig. 1.

3.2.8 *hinge*—the minimum thickness of gasket material between the channel recess and the lock-strip cavity; the plane at which bending occurs when the flange is bent open to receive or release installed material.

3.2.9 *horizontal ladder gasket*—a ladder gasket installed in a vertical plane in such a way that the intermediate cross members (muntins) are vertical members (see Fig. 3).

3.2.10 *ladder gasket*—a lock-strip gasket in the form of a subdivided frame having one or more integrally formed intermediate cross members (see Fig. 3).

3.2.11 *lip*—the inner face of the tip of a flange on a lock-strip gasket (see Figs. 1 and 2).

3.2.12 *lip pressure*—the pressure exerted by the lip of a lock-strip gasket on material installed in the channel when the lock-strip is in place.

3.2.13 *lock-strip or locking strip*—the strip that is designed

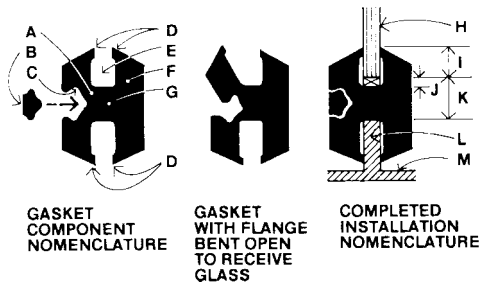

- | | |
|----------------------|----------------------------|
| A Hinge | H Glass or panel |
| B Lock-strip | I Bite |
| C Lock-strip cavity | J Edge clearance |
| D Lip (sealing edge) | K Frame-to-glass dimension |
| E Channel recess | L Frame lug |
| F Flange | M Frame |
| G Web | |

FIG. 1 Basic H-Type Gasket, its Functional Principles and Nomenclature

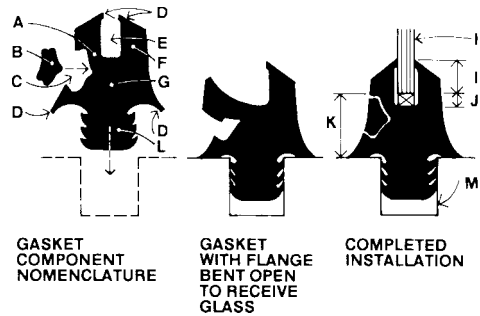

- | | |
|----------------------|----------------------------|
| A Hinge | H Glass or panel |
| B Lock-strip | I Bite |
| C Lock-strip cavity | J Edge clearance |
| D Lip (sealing edge) | K Frame-to-glass dimension |
| E Channel recess | L Spline |
| F Flange | M Reglet |
| G Web | |

FIG. 2 Reglet-type Gasket, its Functional Principles and Nomenclature

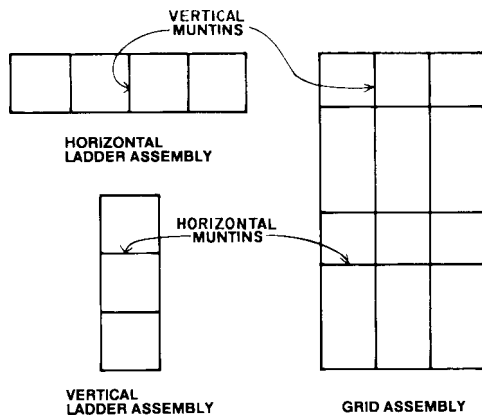

FIG. 3 Gasket Systems

to be inserted in the lock-strip cavity to force the lips against material placed in the channel (see Figs. 1 and 2).

3.2.14 *lock-strip cavity*—the groove in the face of a lock-strip gasket designed to receive and retain the lock-strip (see Figs. 1 and 2).

3.2.15 *muntin*—a secondary intermediate member in a multiple-opening gasket system subdividing a glazed area.

3.2.16 *reglet*—a groove or recess formed in material such as concrete or masonry to receive the spline, or tongue, of a reglet-type lock-strip gasket (see Fig. 2).

3.2.17 *reglet gasket*—See *lock-strip gasket*, and Fig. 2.

3.2.18 *spline or tongue*—that part of a reglet-type lock-strip gasket which is designed to be installed in a reglet in supporting material (see Fig. 2).

3.2.19 *structural gasket*—See *lock-strip gasket*, the preferred term.

3.2.20 *supported gasket member*—a gasket member held in place by a supporting frame member.

3.2.21 *unsupported gasket member*—a gasket member joining infill materials without being held in place by a supporting frame member.

3.2.22 *vertical ladder gasket*—a ladder gasket installed in a vertical plane in such a way that the intermediate cross members (muntins) are horizontal members (see Fig. 3).

3.2.23 *web*—that part of an H-type lock-strip gasket that extends between the flanges, forming two channels and that part of a reglet-type lock-strip gasket which extends between the flanges and spline (see Figs. 1 and 2).

3.2.24 *zipper gasket*—See *lock-strip gasket*, the preferred term.

4. Significance and Use

4.1 This guide provides information and guidelines for the design of lock-strip gasket glazing systems. For related standards, see Specifications C 542, C 716, and C 963.

DESIGN CONSIDERATIONS

5. General

5.1 Structural integrity and watertightness of a gasket glazing system is dependent on interaction of the several components involved. These systems should be carefully designed and built.

6. Components

6.1 The major components of lock-strip gasket glazing and paneling systems are:

6.1.1 The supporting frame of metal, concrete, or other structural building materials,

6.1.2 Lock-strip gasket, serving as an elastomeric mechanical seal and as a retainer for panel or glass, and

6.1.3 Glass or panel infill.

6.1.4 The design of these components and their accessories are interrelated and the total system must be compatible.

7. Supporting Frames

7.1 Supporting frames are made of many materials, of which the more common are aluminum, steel, and concrete.

7.1.1 *Metal*—Die marks, ridges, offsets, and scratches in metal frames in contact with the gasket lips that could cause leakage should be avoided. Metal in contact with any part of the gasket should have sharp edges and burrs removed to avoid the possibility of damage to the gaskets that could result in structural failure through tear propagation. Weathering steel

frames used in gasket installations should be coated to prevent corrosion on the surfaces covered by the gasket to a line not less than 1/8 in. (3.2 mm) beyond the lip edge when installed.

7.1.2 Concrete—Gasket lips in contact with protrusions, crazing, form marks, and offsets on concrete surfaces could cause leakage and glass breakage and such irregularities should be avoided. Concrete frames for lock-strip gaskets should be jointless and are more suitable when precast, as the tolerances and smooth surfaces required are too exacting for cast-in-place concrete. Special forms and meticulous casting procedures are required for optimum performance.

7.1.2.1 Corner Angles—Corner angles in the plane of the glass should be held to $\pm 2^\circ$ tolerance to properly receive the gasket lips. See Fig. 4.

7.1.2.2 Reglets—It is essential that the recess in the concrete be accurately cast so as to properly receive the spline of the gasket. This can be accomplished with a plastic reglet that has a removable weakness membrane as shown in Fig. 4. The removable membrane maintains the proper recess shape and keeps concrete out of the reglet while being cast. The removable membrane can be T-shaped, when desirable, with the stem projecting from the reglet to provide a more convenient means of attachment to the formwork of the concrete panel. After casting, the weakness membrane is easily removed. Plastic reglets are available with flanges extending beyond the gasket lips, providing smooth contact surfaces. An advantage of the plastic flange is the provision of a smooth rigid surface for contact with the gasket lip. The plastic flanges are butted together at the corners requiring a joint which should be properly aligned and sealed. The exposed plastic flange should be solidly cast into the concrete without any voids or honeycombing at the leading edge of the flange because water could enter the interface between the flange and the concrete into which it is cast. An advantage of the flangeless reglet is that the exposed joint between the flange and the concrete as well as the corner butt joints are eliminated and the gasket lips make direct contact with the concrete frame. With this concept it is essential to have a continuous smooth surface free of voids or

honeycombing for the gasket lips to seal against because water could bypass the gasket lip and enter under it. Also important is to have a sharp arris at the corners of the concrete frame so that the corners of the gasket lip can properly contact and seal against the concrete. When plastic reglets are used, joints in them could cause leaks unless sealed. When the gasket lips are in direct contact with the concrete, meticulous casting procedures and close surveillance are required to assure a proper finish along the contacting surface.

7.1.2.3 Frame Lug—It is difficult to achieve watertightness with a gasket gripping the lug of a concrete frame as shown in Fig. 5. Casting the lug to the $\pm 1/32$ -in. (0.8-mm) tolerance required is unrealistic when dealing with concrete. Also, casting it without a tapered draft for ease of form removal results in complicated form work. A tapered draft provides poor control over gasket lip pressure and results in a reduction of pressure when excessive edge clearance permits the gasket lips to slip to the narrower part of the lug. Unless the gasket gripping the lug of a concrete frame has enough mass, insufficient lip pressure against the concrete frame and leakage could result because of the relatively large lug width.

7.1.3 Joints—Ideally, the best type of frame over which to seat the gasket is one without joints. However, the realities of construction should be recognized and dealt with. Watertightness between the lock-strip gasket and frame depends on unbroken pressurized contact. Joints in metal, unless welded and ground flush and smooth, make this concept difficult to achieve. Members on either side of a butt joint should be installed as true to plane as possible. If the design relies upon sealed metal-to-metal joints, the small void between the gasket lip and metal should also be sealed with a supplementary sealant. A recommended safeguard is to have a built-in drainage system within the frame. In this way, any water penetrating the frame joints or gasket to frame joints will be directed back to the outdoors. An aid towards minimizing the possibility of water penetration between the gasket and frame at static (fixed, nonmoving) metal joints in single openings may be seen in Fig. 6. The direction of the joint is horizontal between the horizontal and vertical members at the top of the frame, and vertical between the horizontal and vertical members at the bottom of the frame.

7.1.4 Frame-to-Gasket Lips Clearance—Because lip pressure is critical in resisting the passage of water, the design of the supporting frame must allow at least 1/8-in. (3.2-mm) clearance between the installed gasket lip and any projecting

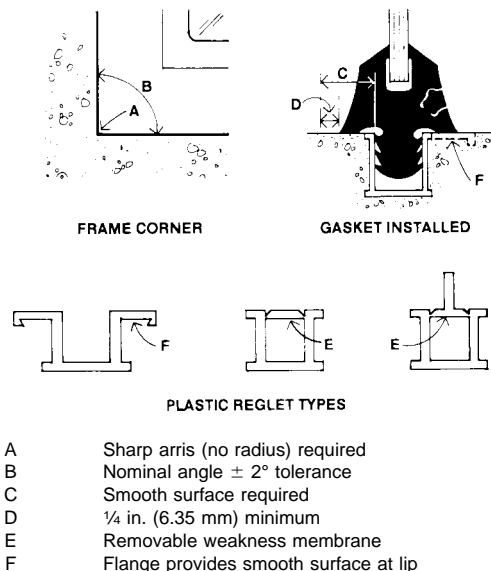
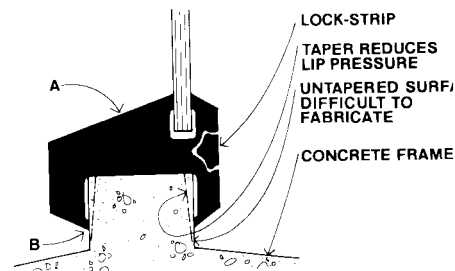

FIG. 4 Reglet-type Gasket in Concrete



NOTE 1—Insufficient mass at A and relative long distance from B to lock-strip minimizes potential for adequate lip pressure at B.

FIG. 5 Gasket Mounting on Concrete Lug

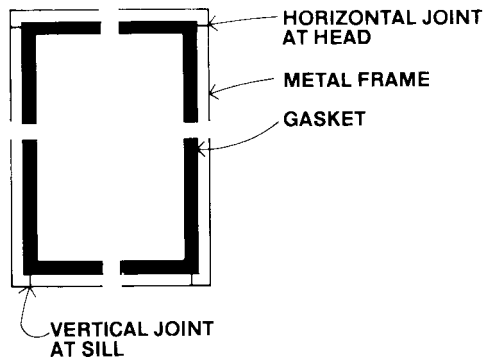

FIG. 6 Single-opening Metal Frame Joints for Increased Watertightness

flanges or fillets. This allows the lips to exert unrestricted pressure against the frame as shown in Fig. 7. Where the frame lug and projecting flange form a fillet, the recommended clearance should not include the convex portion.

8. Gaskets and Accessories

8.1 To accommodate the wide variety of glass and panel thicknesses available as well as allow for mounting to various types of framing members, a wide variety of gasket cross sections are produced by the extrusion manufacturing process. The technique of extruding varies among the manufacturers, and has a limiting factor on the complexity of cross-section designs produced.

8.1.1 Gasket Types—Lock-strip gaskets are typically identified by their general cross-section configuration. The most common are H-type and reglet type. Other special and proprietary interlocking types have been developed as a result of modifications to the basic types, usually because of provisions for mounting or mating to special framing members. Gasket sections are generally of two types: the perimeter section and the muntin section.

8.1.1.1 H-Type—The basic H-type gasket, its installation, and nomenclature are illustrated in Fig. 1. After the gasket is installed over the frame and the glass or panel infill installed in the gasket, the lock-strip, which is of higher durometer, is forced into a groove in the gasket. A resultant compressive force is transferred to the lips which apply pressure to the frame and glass. Sufficient lip pressure against smooth surfaces creates an effective weathertight seal. A wide selection of H-type gaskets are available that accommodate glass, panels, and frame lug thicknesses ranging from 1/16 to 1 1/4 in. (1.6 to 31.75 mm). Gaskets accommodating thicknesses greater than 1 1/4 in. are also available. Thick panels should not be mounted on relatively thin lugs as the weight of the glass or panel cannot

be supported properly. The best performance can be expected where the lug thickness equals or exceeds the thickness of the glass or panel. There are exceptions to this recommendation which are dependent upon other factors, such as lightweight panels, extremely small openings, or situations where total performance is not required. Acceptable deviations require engineering analysis, consultation with the gasket manufacturer, and testing.

8.1.1.2 Reglet Type—The reglet-type gasket is a patented type whose functional principles and nomenclature are illustrated in Fig. 2. Reglet-type gaskets are designed with a spline that fits into a reglet. The seal against the frame is accomplished by forcing the spline of the gasket into the reglet so that the fins on the side of the spline retain the gasket in the reglet and thus hold the sealing lips of the gasket tightly against the frame surface. The seal against the glass or panel is accomplished by the insertion of the lock-strip as with the H-type gasket. Most reglet-type gaskets are designed to fit into a reglet that is 3/4 in. (19.05 mm) deep and 5.8 in. (15.9 mm) wide. If the reglet is of lesser depth, the gasket will “bottom-out” and not provide a proper installation. If the reglet is too wide, the gasket will not be held in place properly and thereby provide difficult glass or panel installation. If the reglet is too narrow, the gasket will be difficult to install. Reglet-type gaskets are available that accommodate glass or panel thicknesses from 1/16 through 1 1/4 in. (1.6 through 31.75 mm). There is an important basic difference between the H-type and reglet-type gaskets that should not be overlooked in field application. The lock-strip of both gaskets causes lip pressure against the frame and glass, but with the reglet-type gasket, lip pressure is also affected by the depth of the gasket spline in the reglet. This is controlled by the installer at the site as well as by the geometry of the gasket and reglet. Available are reglet-type gaskets that have projecting offsets at the upper or lower part of the spline. These are designed to control the depth at which the spline is inserted into the reglet.

8.1.1.3 Special Interlocking and Proprietary Types—In addition to the basic H-type and reglet-type gaskets, there are various special interlocking and proprietary type gaskets. Several of these are illustrated in Fig. 8. The basic principle of the interlocking type is to achieve greater roll-off resistance of the gasket from the frame by mechanically interlocking the gasket to the frame.

8.1.2 Gasket Joints—Best sealing performance is achieved with a continuous gasket having factory-formed injection-molded joints. In the use of discontinuous ladder-type gaskets or stick systems (assembled in the field, using cut lengths), achieving a weathertight seal requires a field application of sealant or adhesive recommended by the gasket manufacturer. Geometric continuity should be achieved at the juncture of extrusion and molded joint. Sharp offsets, the limits of which have not as yet been established, can break the continuity of the lip seal and prevent or reduce water tightness.

8.1.2.1 Corners—Continuous and adequate lip pressure provided by the gasket against frame and glass is a key factor in the design of the gasket for watertightness. A pressure of 4 lbf/linear in. (7 N/linear cm) has been determined to be the minimum that will satisfy this requirement. However, of

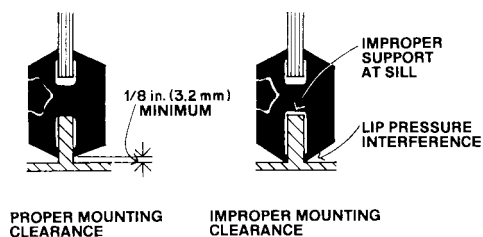

FIG. 7 Gasket Mounting Clearance

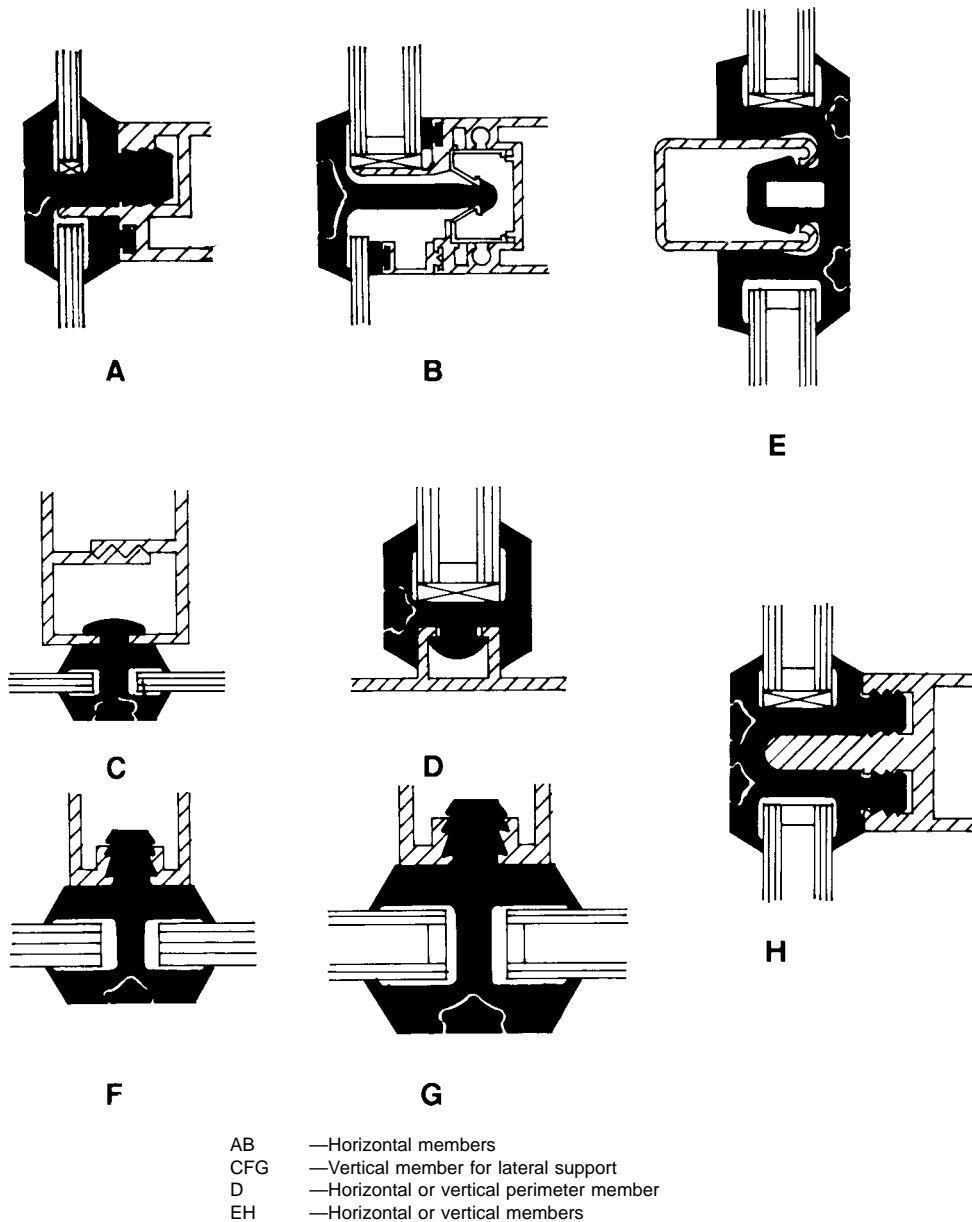

FIG. 8 Special Interlocking and Proprietary Type Gaskets

utmost importance is the requirement that this pressure be continuous and uniform at every point along the lip of the gasket. The present lip pressure test in Specification C 542, is a test for average lip pressure over the entire test specimen length. When applied to the extruded portion of the gasket, it can reasonably be assumed that the pressure would be continuous and uniform at every point, provided the gasket lips are not damaged. This is not necessarily true of the molded corners. Gaskets of various corner designs can pass the lip pressure test, but not all have the capability of sealing out the passage of water. This may be the case with a corner having square lips on the frame side where, because of the longer diagonal distance to the lock-strip, little or no lip pressure may be obtained at the apex. It should not be assumed that passage of the lip pressure test in Specification C 542 provides assurance that the gasket is adequate for resistance to the passage of water. Gasket corner

designs having square lip seals are not as common as previously. Gaskets having approximately 1/4 in. (6.35 mm) radius at the external corner lips are now available. With such a design, a more uniform edge distance is maintained from the lip edge to the lock-strip as shown in Fig. 9. In this way, lip pressure is

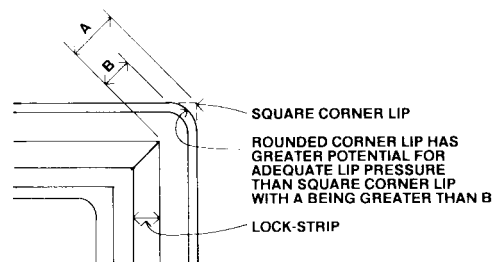

FIG. 9 Gasket Corner Design Features

not generally reduced around the corner as with a square lip because of the appreciably longer moment arm. Generally the round lip is concealed by an external noncontacting square lip for appearance but the seal is provided by the contacting round lip. The angle of the gasket molded corner should conform within 5° to the corner angle of the frame. Molded corner angles of less than 45° should be avoided as the insertion of an extremely acute corner angle is impossible without damage to the molded corner or panel unit.

8.1.2.2 *Tees and Crosses*—Tees permit the juncture of the perimeter member of a gasket to a muntin member. Crosses allow for division of a glazed area horizontally and vertically. Crosses and tees can be injection molded as well as corners. The corner angle conformation tolerance of $\pm 5^\circ$ is also a requirement for tees and crosses.

8.1.2.3 *Butted Joints*—Where feasible, long sections of gaskets should be joined end to end by factory-injection molding. Where field-butt joints are required, an application of sealant or adhesive recommended by the gasket manufacturer should be used in the joint under compression to achieve weathertightness.

8.1.3 *Lock-Strips*—The purpose of lock-strips is to apply pressure to the gasket sealing lips, causing the lips to grip and seal against both the frame and the glass or panel. Lock-strips may be separate from, or an integral part of, the gasket proper. The separate lock-strip should be 10 points harder in Shore A durometer than the gasket itself. The additional hardness of the lock-strip resists deformation under compression and maintains the designed gasket lip pressure for longer periods than would a lock-strip of equal size of a lower durometer.

8.1.4 *Gasket Systems*—A gasket system is produced when perimeter gaskets and muntin gaskets are assembled and designed to mate with corresponding frame members as a total unit. Gasket systems are referred to as (a) supported, in which all the muntin members are metal supported gasket members; or (b) unsupported, in which vertical muntin gaskets are unsupported by metal members. Supported systems should be used where optimum performance is required.

8.1.4.1 *H-Type System*—An H-type system uses an H-type gasket for the perimeter as well as for the muntins. This system permits using a glass panel and a spandrel panel, or a glass panel and a panel containing an operating window insert, in the same system. The gasket manufacturer should be consulted prior to designing such a system, to ensure that perimeter and muntin gaskets are compatible and can be joined together to produce a favorable system.

8.1.4.2 *Reglet-Type System*—A reglet-type system typically includes a reglet-type gasket for the perimeter and a supported or unsupported H-type gasket for the muntins. The reglet type systems require a greater control over the opening dimensions, particularly if the opening is of concrete. The tolerances published by the gasket manufacturer for reglet-type systems should be followed.

8.1.4.3 *Stick System*—A stick system incorporates gaskets that are straight lengths of extrusions cut to size and joined during installation in the field. Manufacturer's recommendations should be followed regarding the installation techniques to be used as well as the type and location of adhesives or

sealants to be used for the joints.

8.1.4.4 *Ladder Assembly System*—A ladder assembly system is produced by vulcanizing muntin gasket extrusions to perimeter gasket extrusions with the use of an injection-molded Tee-joint. These may be vertical or horizontal ladder assembly systems as shown in Fig. 3. Production experience shows that a ladder gasket assembly larger than 20 ft (6.1 m) in length becomes too difficult to fabricate or handle. Field installation problems are also encountered. Where large areas are to be glazed using the ladder gasket assembly, the assemblies are produced in conveniently sized sections, and joined in the field. Joining is accomplished by butting under compression ("crowding") the free ends of the gaskets together. A weather-tight seal can be accomplished by the injection of an appropriate adhesive or sealant recommended by the gasket manufacturer in the butted gasket joint after the unit is glazed and lock-strip inserted. In horizontal ladder systems where the vertical gasket member is unsupported the vertical gasket is used only as a weather seal and does not provide any significant structural support to the vertical glass edges. For vertical ladder systems the horizontal gasket members must be supported (see 10.1.10.4).

8.1.4.5 *Grid Assembly System*—A grid assembly system is one in which horizontal and vertical muntin gaskets intersect within the perimeter gaskets as shown in Fig. 3. Intersecting muntin gaskets are assembled by a molded joint. All grid systems should be of the supported type.

8.1.5 *Setting Blocks*—The purpose of setting blocks is to provide positive support, but prevent direct contact between the bottom of the glass or panel and the web of the sill gasket member. A certain amount of vertical edge clearance is required in order to install the gasket without tearing the upper corners of the gasket. If the glass or panel were to be installed directly onto the web of the sill gasket member, too much edge clearance would be left at the head member. With setting blocks, the glass or panel can be lowered down to the web of the sill member for easier glass insertion at the head and then raised within the gasket enclosure for insertion of setting blocks to provide the desired edge clearance space at the sill member before the lock-strip is installed. Factors to consider in the use of setting blocks are (a) compatibility of materials, (b) location and quantity, (c) avoidance of support at the gasket corners, (d) maximum pressure permitted on the gasket-bearing surface under the setting blocks, and (e) geometry of the setting blocks with regard to the gasket, to the gasket cross section, and glass or panel width.

8.1.5.1 *Material*—The setting block material should be an elastomer of Shore A durometer of 85 ± 5 , of rectangular cross section, dimensionally stable, causing no interactive deterioration of it, the gasket, or the glass or panel infill and in compliance with Specification C 864.

8.1.5.2 *Location*—A continuous strip or two setting blocks at the quarter points are permissible, provided the maximum pressure described in 8.1.5.3 is not exceeded. The continuous strip should be cut short of the width by 4 in. (101.6 mm).

8.1.5.3 *Width*—The width of setting blocks should be 0.05 in. (1.27 mm) less than the nominal glass or panel thickness. Less width could result in improper support for the glass or

panel. Greater width could result in a loss of weathertightness as illustrated in Fig. 10.

8.1.5.4 *Depth*—The depth of setting blocks should be such as to vertically center the panel in the gasket opening thus equalizing the clearances on top and bottom. However, edge clearance should not be increased to the extent that required push-out capacity is jeopardized (see 10.1.1).

8.1.5.5 *Length*—The total cumulative length of the setting blocks should be a minimum of L as defined herein, and a maximum of the opening width less 4 in. (101.6 mm), so as to ensure a minimum expansion of the gasket web at the pressure points.

$$L = W/PT$$

where:

- L = total cumulative length of setting blocks, in. (mm),
- W = weight of glass or panel, lb (kg),
- T = thickness of glass or panel, in. (mm), and
- P = bearing pressure of glass or panel on setting blocks, max = 15 psi (103 kPa).

8.1.6 *Edge Spacers*—When installing unsupported vertical ladder assembly gasket systems, installation of a continuous rubber edge spacer is required between the head of each glass or panel and the web of the gasket muntin above. This procedure maintains the muntin center line at its proper elevation during installation and to prevent the possibility of future settling of stacked lights. The configuration and Shore A durometer of the edge spacers should be as recommended by the manufacturer of the gaskets but no less than that of the gasket.

8.1.7 *Weepholes*—Weepholes in the sill portion of the gasket can be used to drain away water that has entered between the gasket lips and glass during driving rain and gusting winds. Glass manufacturers require that weepholes be used with insulating, wired, and laminated glass, as water trapped in the gasket channel can have detrimental effects on such units. Weepholes in single glazing is optional.

8.1.7.1 *Size and Location*—Weepholes, when used, should be ¼ to ⅜ in. (6.35 to 9.35 mm) in diameter and at least three per opening with one at the center and one at each end between setting block and corner. Whenever possible, provide the weepholes in the web of the gasket so that the water can drain down into the frame and then be channeled outward, in preference to draining outward through the flange of the gasket, as shown in Fig. 11. Weepholes in the flange permit unwanted water to drain outward but can conceivably also permit water to enter from one side of the system to the other

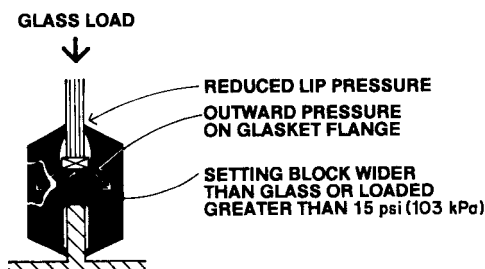
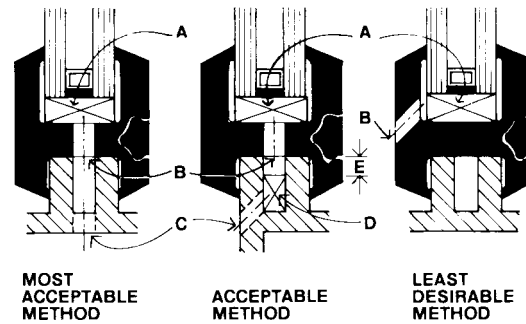

FIG. 10 Effect on Gasket Caused by Too Wide or Overloaded Setting Blocks



- A Setting blocks at ¼ points
- B Weepholes not covered by setting blocks (center between and on each side of blocks near jambs)
- C Weepholes in frame
- D Open-cell polyurethane pad behind each weephole in frame
- E ¼ in. (6.35 mm) minimum clearance when pad is in line with weephole above

FIG. 11 Gasket Drainage Systems

under certain conditions of pressure differential. On the other hand, weepholes could possibly serve to reduce pressure differential within the system. The use of an open-cell polyurethane pad behind each weephole in the metal frame keeps out insects and excessive water penetration while still permitting water to drain gradually back to the outside. When reglet-type gaskets are used, it is recommended that the reglet also be drained to the exterior where feasible. This can be achieved with plastic drain tubes. A minimum of two tubes are recommended with a ⅜-in. (9.35-mm) inside diameter. Assembly testing can best determine the effect of weepholes in the system.

9. Infill Materials

9.1 The more predominant materials placed into and gripped by lock-strip gaskets are glass, plastic sheet materials, and a variety of panels.

9.1.1 *Glass*—The numerous factors affecting the structural integrity of glass when used in lock-strip gasket glazing systems make it advisable that the glass manufacturer be consulted for glass selection and strength of the product to be used. The basic strength characteristics of glass products, particularly tinted and coated glasses, are affected by perimeter treatment and bite. Their influence on the structural performance of the entire system are described under 10.1.4.

9.1.1.1 *Edge Treatment*—The edges of many types of glass cannot be altered after fabrication. These types include heat-strengthened, tempered, spandrel (heat-strengthened or tempered), insulating, and laminated glass of three or more plies. Other types should not be altered by the glazier unless a good clean-cut edge is assured. Nipping, grinding and, in some cases, seaming of the edges should not be permitted (see 10.1.4). Other requirements are as follows:

(a) *Insulating Glass*—The dimensions of insulating glass cannot be altered after fabrication. Some insulating glasses were fabricated with a protective or structural metal edge channel. The channel serves a definite purpose and should not be removed if resetting the glazing; as under most conditions, removal of the edge channel voids the manufacturer’s warranty.

(b) *Tinted and Coated Glasses*—Tinted (gray, bronze, and green) and coated glasses, both single and laminated, are furnished with factory edges which may vary with manufacturers, glass types, and thicknesses. In each case the edgework represents the manufacturer’s best judgment. Field cutting should be avoided, but when necessary only a clean-cut edge should be allowed. When acceptable to the glass manufacturer, scarfing or rounding of the corners (intersections of edges) of the glass may be done, using a 180-grit or finer emery cloth or sandpaper to help prevent damage to the gaskets.

(c) *Clear Glass*—Regular plate or float and sheet glasses can be successfully field cut, provided sufficient glass is removed to prevent nipping and “run-outs.” Their edges may be seamed and their corners scarfed, provided a fine emery cloth or sandpaper (180-grit or finer) is used. Cut sizes supplied by the manufacturers normally are clean-cut. In some cases large lights of heavy-duty glass may have special factory edges.

(d) *Heat-Strengthened and Tempered Glasses*—These types of glass are usually furnished with seamed edges. Edge or corner treatment must be accomplished before tempering. After fabrication, edges (including corners) should not be modified in any way.

(e) *Patterned Glasses*—Patterned glasses with a deep pattern cannot be installed in gaskets with good assurance against water infiltration. When this type is being considered, the feasibility of using a gasket system can best be determined by assembly testing.

9.1.1.2 *Bite*—For tinted and coated glasses, both monolithic and insulating, the following maximum bites on the glass should be adhered to as closely as possible. Excessive bite may result in serious thermal stresses which may materially contribute to glass breakage, especially when other stresses are simultaneously placed on the glass. Minimum bite is governed by the maximum edge clearance permitted for structural reasons (see 10.1.1).

Glass Thickness, in. (mm)	Maximum Bite, in. (mm)
¼ (6.35) or thinner	⅜ (9.35)
⅜ (9.35)	7/16 (11.06)
½ (12.7)	½ (12.7)
Insulating glass	9/16 (14.22)

Some manufacturers will permit greater bite than 9/16 in. (14.22 mm) for insulating glass (particularly when tempered) but should be confirmed by the manufacturer.

9.1.1.3 *Strength Criteria in Unsupported Gasket Members*—In multiple-opening gasket systems, unsupported members do not provide any significant stiffening influence (see 8.1.4). Insulated units are not to be used in unsupported gasket systems. They require metal or other type structural members on all edges. Also, monolithic glass thickness and strength for such openings must be chosen to meet two-side or three-side support conditions. This usually requires significant increases in glass thickness or heat strengthening or tempering of the glass.

9.1.2 *Sheet Plastic*—Because of the greater coefficient of expansion and greater flexibility of plastic compared to glass, the criteria for glass cannot be used for sheet plastic.

9.1.2.1 *Flexibility*—Acrylic and polycarbonate sheets are extremely flexible in sizes and thicknesses normally used in glazing installations. This should be considered in evaluating

the resistance to push-out afforded by the gasket. Specific data regarding deflections of sizes and thicknesses and minimum bite to be used should be obtained from the plastic manufacturer.

9.1.2.2 *Use of Solvents*—Many common solvents such as gasoline, benzene, and acetone, will cause deterioration of the surface of acrylic and polycarbonate sheets. The plastic manufacturer should be consulted and his instructions followed, regarding acceptable cleaning materials harmful to the surface of the plastic.

9.1.2.3 *Thermal Expansion*—Reference should be made to the manufacturer’s literature regarding provisions for thermal expansion of the plastics. In large sizes the edge clearances required for expansion prohibit the use of standard gasket cross sections.

9.1.2.4 *Edge Treatment*—Sheet plastics are not notch-sensitive, and treatment of edges is not as significant as for glass. Edges may be sawed and seamed. Apparent fissures or cracks at the edge, however, are cause for rejection.

9.1.2.5 *Tolerances*—Dimensional and thickness tolerances for acrylic and polycarbonate sheets for glazing are available from the manufacturer. There are not established standards in this regard, and early consultation with the plastics manufacturer is recommended.

9.1.3 *Panels*—Metal and various other laminated materials can be installed and held weathertight in lock-strip gaskets. Criteria for use are generally the same as for glass. In addition, the following requirements govern the use of panels:

9.1.3.1 *Edge Strength*—Edge strength should be adequate for gasket glazing to prevent crushing during insertion and to resist permanent deformation when loaded.

9.1.3.2 *Corrosion Protection*—Surfaces should be noncorrosive or protected with a noncorrosive coating. Weathering steel should have the portion hidden in the gasket plus a minimum of ⅛ in. (3.18 mm) exposed surface coated with a protective coating.

9.1.3.3 *Edge and Corner Treatment*—No sharp edges or corners should be permitted unless protection is provided. Wherever possible, corners should be rounded. A suitable tape is feasible for protection against sharp edges but not against sharp corners. When used, the tape should not extend onto the face of the panel by more than ⅛ in. (3.2 mm) so that it does not interfere with the contact of the gasket lips against the panel.

9.1.3.4 *Surface Smoothness*—Surfaces should be smooth and free of offsets around the perimeter, where contacted by the gasket.

9.1.3.5 *Insulated Panels*—Insulated sheet metal panels should have the facing metal flanged and overlapped at edges to avoid contact of sharp edges and corners with the gasket.

9.1.3.6 *Weight*—The weight of the panel should be so limited that the load transmitted to the gasket web at the bottom of the panel is no greater than 15 psi (103 kPa) unless permitted by the gasket manufacturer.

9.1.3.7 *Weepage*—Provide weepholes in gaskets retaining insulated metal panels or those which have unprotected cores which can be damaged with moisture.

10. Factors Affecting Performance

10.1 Since lock-strip gaskets are elastomeric mechanical seals that grip the supporting frame and glass or panel infill, structural performance is of prime importance, and all factors that affect such performance must be considered in the design of a lock-strip gasket glazing system. In addition to glass or panel strength, the more critical factors are edge clearance, bite, centering of glass or panel, glass edges and corners, deflection of glass or panel lubricants, gasket design, gasket fabrication, frame and glass tolerances, and supporting frame design.

10.1.1 *Edge Clearance*—Investigations and reports of various tests performed to date indicate that glass-to-web and frame-to-web edge clearances, with the resultant frame-to-glass distance, is an extremely important factor in determining the structural capacity of the gasket to resist push-out of the glass from the gasket or roll-off of the gasket from the supporting frame when subjected to wind loads. The greater the frame-to-glass dimensions, the more critical becomes the structural capacity of the gasket to resist push-out or roll-off. This can be analyzed by observing Fig. 12, which is a schematic drawing representing the configuration of the gasket under load. P is the resultant unit load imposed on the lips of the gasket from wind loads acting on the glass, and D is the distance between the glass edge and the supporting frame. The gasket is flexible, but must have sufficient flexural strength to resist, within acceptable limits of flexure, the moment developed as a product of P and D . With P being a constant for a given load on the glass, it can be seen that the variable D becomes a critical factor relative to the structural capacity of the gasket. The gasket clearance, as measured after the installation is complete, must ensure sufficient grip of gasket lips on both the supporting frame and panel or glass. For economical installations and prevention of tearing of the premolded corner in the process, this clearance should be as large as possible, but for maximum strength and weathertightness a minimum clearance is preferable. Any subsequent differential movement or

dimensional change of supporting frame and infill panel or glass should result in a gasket clearance that is neither beyond the maximum design value nor zero. Nominal clearance around all sides of the panel or glass should ideally be $\frac{1}{8}$ in. (3.2 mm) with the bottom clearance being maintained by setting blocks.

10.1.1.1 *Structural Capacity and Lip Pressure*—Structural capacity of a gasket to resist push-out or roll-off should not be confused with lip pressure values. Specification C 542 requires that the lip pressure of a gasket should be a minimum of 4 lbf/linear in. (7 N/linear cm) to provide an adequate and lasting seal. It should not be assumed that a gasket meeting this requirement has sufficient structural capacity to resist 4 lbf/linear in. of push-out or roll-off pressure. It may be able to resist more or less pressure depending on several factors, including the amount of edge clearance which is of major importance.

10.1.1.2 *Design Limits*—The resultant average unit load on the gasket, determined by dividing the total load on the contained glass or panel by the perimeter length, increases more rapidly when related to area increase than when related to perimeter increase. The larger areas and thicker lights of glass, therefore, more critically affect the ability of the gasket to resist roll-off. Although there are many factors to consider, tentative design criteria presently advocated by glass and gasket manufacturers for basic H-type gaskets with normal four-side support is to limit their use with flat glass having a thickness of $\frac{3}{8}$ in. (9.35 mm) and under to a maximum opening area of 100 ft² (929 m²) and to limit their use with flat glass $\frac{1}{2}$ in. (12.7 mm) or more in thickness to a maximum opening of 60 ft² (557.4 m²). These data are based on a standard glass wind load performance chart utilizing a 2.5 design factor.

10.1.2 *Bite*—With the gasket snugged to the frame, the minimum bite or grip on the panel or single glass should be $\frac{1}{4}$ in. (6.35 mm) and $\frac{1}{8}$ in. (3.2 mm) beyond the metal edging on insulated glass even though published design push-out resistance of the gasket selected may otherwise be determined adequate.

10.1.3 *Centering of Glass or Panel*—To achieve optimum structural performance, the glass should be centered in the opening. Since edge clearance is an important factor, centering the glass will give uniform edge clearance all around. Normally the weakest point in push-out or roll-off resistance occurs where the clearance is the greatest. Setting blocks are recommended so that the glass can be centered vertically. Dynamic wind loads and movement of frame members can cause the glass to shift off center. A possible aid in preventing this could be the insertion of continuous edge spacers between the glass edges and the gasket web at the jambs. These can be difficult to install, however, since they must be inserted after the glass is in place and before the lock-strip is secured. Although no test data presently exist, a feasible compromise could possibly be to insert short strips of edge spacers in the vertical portion of the lower corners and molded L-shaped spacers around the upper corners of the glass. The horizontal upper leg would prevent the vertical lower leg from dropping down. With either method, the size, shape, and compressibility of the edge spacers must be carefully sized to avoid decreasing the necessary lip pressure against the glass.

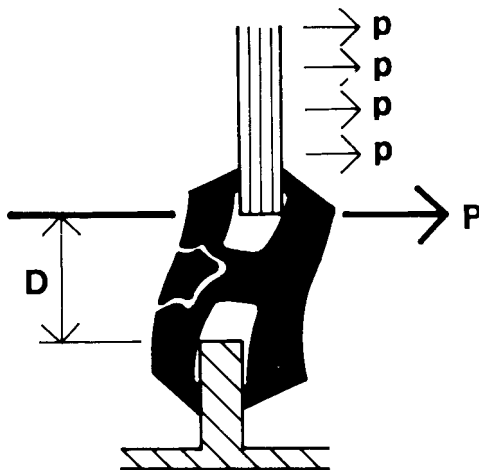

- p Unit area load on glass
- P Resultant linear load on gasket
- D Frame-to-glass edge dimension
- PD Moment to be resisted by the gasket

FIG. 12 Roll-off Forces Acting on Gasket

10.1.4 *Glass Edges and Corners*—Seaming glass edges to reduce their sharpness can reduce the strength of glass significantly and, contradictory as it may appear, the process of seaming glass edges so that they feel smooth to the touch actually creates numerous minute cuts or weakness points. Glass manufacturers will in some cases, as for thinner lights of ordinary clear glass, condone seaming edges but should be consulted as to feasibility and method (see 9.1.1.1). Since thermal stresses are greatest at the center of the glass edges and approach zero at the corners, some glass manufacturers will permit the corners to be rounded slightly. When acceptable to the glass manufacturer, this is an important aid to the installation of the glass with minimum edge clearance and eliminates the possibility of sharp corners cutting the lips or web of the gasket. When considered desirable, the gasket can be protected against the sharp edges of clean cut glass by taping them with a suitable tape. However, the tape should not extend onto the surface of the glass by more than $\frac{1}{8}$ in. (3.2 mm) so that it does not interfere with the contact of the gasket lips against the glass. Rounding of corners would not apply to insulating glass.

10.1.5 *Deflection of Glass*—On large lights of glass, having thicknesses of $\frac{1}{4}$ in. (6.35 mm) or under, large deflections occur under wind loading at the center of the glass in a direction perpendicular to the plane of the glass. This increases edge clearance and thereby reduces the push-out resistance of the gasket.

10.1.6 *Lubricants*—Lubricants are useful, and even essential, for facilitating the installation of gasket glazing systems. However, when lubricants are carelessly applied and are placed on the gripping surfaces of the frame, gasket, and glass, serious reductions in structural performance can result. Since the installation is made easier with lubricants, it stands to reason that push-out or roll-off resistance is decreased. Lubricants should be compatible, nonstaining products that ideally will evaporate and become ineffective soon after placement. Lubricants exposed to the exterior generally evaporate and become ineffective soon after placement, but this is not necessarily true where the lubricants are literally bottled up in the critical gasket channels that receive the glass and frame. The lock-strip cavity should be lubricated to ease the installation of the lock-strip and does no harm. There is no reason to place lubricant on the supporting frame or in its gasket channel, and this should not be permitted. It is normal practice to place lubricant in the glass-side gasket channel as this eases installation. However, this decreases structural performance capability as long as the lubricant is fluid. Therefore its use in this location should be kept to an absolute minimum or not used at all if required structural performance cannot be achieved with it.

10.1.7 *Gasket Design*—The structural performance of a gasket is influenced by its configuration, mass, and the compound used in its formulation. To attempt to improve any one property or change any one dimension of a given gasket design will generally affect others.

10.1.7.1 *Web Thickness*—One of the more critical dimensions that affects structural performance is web thickness. The greater the thickness, the greater the frame to glass dimension and the push-out or roll-off moment which must be resisted by

the flexural strength of the gasket.

10.1.7.2 *Asymmetry*—Due to asymmetry of the gasket and the greater hardness of the lock-strip, different performance could result under a given directional load, depending on which side of the gasket the push-out force is applied.

10.1.7.3 *Mass*—Another critical feature is the overall mass of the gasket. Too often the gasket selected has insufficient channel depth to accommodate the cumulative tolerances of frame, glass, edge clearance, and bite for a particular set of conditions. Were the gasket channel depth to be increased, the overall gasket mass would accordingly have to be increased to achieve adequate lip seal pressures.

10.1.7.4 *Channel Depth*—It is important to note that there are maximum limits for gasket bite when related to the type of glass used. The glass manufacturer's recommendations on bite should be followed for the type and thickness of glass used (see 9.1.1.2).

10.1.7.5 *Rubber Compound*—Another critical feature affecting structural performance of the gasket is its rubber compound. Physical properties such as tensile strength, elongation at rupture, tear resistance, hardness, compression set, and brittleness are affected by the manufacturer's proprietary formulation. Specification C 542 has established the physical property requirements of lock-strip gaskets and these should be complied with.

10.1.8 *Gasket Fabrication and Tolerances*—Although the basic gasket design and formulation may be adequate, quality control must also be provided to ensure that any deviations in fabrication runs are held to acceptable limits. Of critical concern is the juncture of the extruded portion of the gasket with the molded corner. Offset lips can occur at this point if fabrication is not carefully controlled. The permissible tolerances for physical properties and dimensions specified in Specification C 542 must be maintained for proper performance. Gaskets should be installed under uniform linear compression. To achieve this, gasket lengths, including the lock-strips, should be $\frac{1}{2}$ to 1% longer than the measured opening. The lesser "crowd" is used with the larger gasket cross sections.

10.1.9 *Frame and Glass Tolerances*—Fig. 12 illustrates the importance of frame-to-glass distance as related to push-out and roll-off resistance. It is essential, therefore, that acceptable tolerances for both frame and glass be established for each project and complied with, so that edge clearance does not exceed acceptable limits. The glass manufacturers are in general agreement on the dimensional tolerances of insulating glass as well as the cutting tolerances of flat glass and have published applicable data for their products. For flat glass, tolerances established in Specification C 1036 must be complied with to be compatible with gaskets in compliance with Specification C 542. For insulating glass tolerances, the glass manufacturer should be consulted. Normal plumbness, out of square, and opening tolerances for the supporting frame can vary with the type of frame material used, as well as with the method of fabrication. The frame lug that receives an H-type gasket must be within $\pm \frac{1}{32}$ in. (0.8 mm) in width to be compatible with gaskets in compliance with Specification C 542. A careful analysis of all tolerances in the system are

required to achieve a structurally sound, yet economical design.

10.1.10 *Supporting Frame Design*—Since all loads on the gasket are transferred through the gasket to the supporting frame, it is essential that the frame has sufficient strength to adequately support the loads within certain limits of deflection, racking, and rotation of members. The frame should not be the weakest part of the whole system, and a frame that permits the glass to fail before the glass can reach its ultimate strength indicates at best an uneconomical design. The structural capacity of the supporting frame is first determined by engineering analysis. Only by testing an assembled mockup of all components can the frame be more realistically evaluated as to its performance under load.

10.1.10.1 *Building Sway*—Not to be overlooked in calculating the movement of the frame is the effect of building sway under wind pressure. Since the supporting frame is generally attached to the structure so as to move with it, structural movement that causes racking in a direction parallel to the glass can be a significant factor when one adds up the cumulative effect on edge clearance and the lessening of push-out resistance.

10.1.10.2 *Seismic Loading*—Racking movement can also be caused by seismic loads and should be considered in areas where such occurrences may be prevalent.

10.1.10.3 *Eccentric Loading*—Eccentric loading of the glass with respect to the thickness of the supporting frame can, under certain conditions, affect water penetration as well as structural performance. This can occur when the glass is considerably thicker than, or offset from, the frame support below it, and the gasket cannot properly support the load without excessive deformation. When insulating glass is used, its perimeter seal can be jeopardized if full width frame support is not provided at the bottom of the glass. Eccentric loading causes a constantly applied torque on the cross section of the gasket. This can reduce in-place lip pressure below required limits, although the gasket as a component may be able to satisfy minimum lip pressure requirements. Assembly testing is required for proper evaluation.

10.1.10.4 *Vertical Ladder-Type System Support*—In vertical ladder-type installations as illustrated in Fig. 3, where the horizontal gasket members are unsupported, the vertical load of a light of glass is transferred through the gasket web to the light below. Laterally unsupported vertical ladder-type installations are not recommended (see Fig. 13), because of the unacceptable practice of transferring load to successive lights of glass. Furthermore, watertightness and pushout resistance depend on proper shimming being provided in the clearance above and below the gasket web, so that the vertical load may be properly transmitted downward from the light above to the light below without slippage of the glass within the gasket and

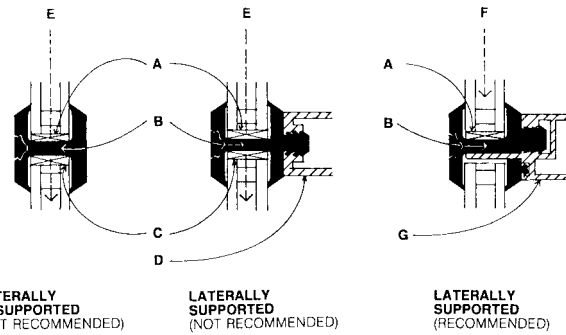

- A Setting blocks
- B Web
- C Spacers
- D Laterally supporting muntin
- E Vertical load transfer through setting blocks, web, and spacers to glass light below is not recommended.
- F Vertical load transfer through setting, blocks, and web to supporting muntin is recommended
- G Laterally and vertically supporting muntin.

FIG. 13 Vertical Ladder Assembly Horizontal Muntin

sagging or overloading of the horizontal gasket member. This type of system requires consideration of the number of lights that may be stacked vertically, glass size and strength, vertical thermal movement, compressive load on the web of the gasket, and other architectural and engineering design factors. In some vertical ladder-type installations, special proprietary gasket shapes are used to interlock with the frame on one side of the gasket, and the vertical load of each light of glass is transmitted eccentrically to the frame. Such gaskets, as well as the system used, must be carefully engineered and tested to assure proper transfer of load from glass to frame. Flat glass, limited by size and weight, has been used in this manner in gaskets similar to Types A, B, E, and H shown in Fig. 8.

11. Assembly Testing

11.1 Appropriate testing is of major importance when determining what type of performance may be expected from the design, fabrication and installation of a lock-strip gasket glazing system. Specification C 542 is basically a specification for testing of only the properties of the gasket component in a system. Testing of the complete assembly for air infiltration, water penetration, and structural performance can be accomplished by using Test Methods E 283, E 330, and E 331. "Heat Release Data Under Uniform Specimen Thermal Exposure Using the IMO Flammability Test," *FP/385 (USA)*, International Maritime Organization, London, March 27, 1985.

12. Keywords

12.1 elastomeric; glazing; lock-strip gasket; sealant

The American Society for Testing and Materials takes no position respecting the validity of any patent rights asserted in connection with any item mentioned in this standard. Users of this standard are expressly advised that determination of the validity of any such patent rights, and the risk of infringement of such rights, are entirely their own responsibility.

This standard is subject to revision at any time by the responsible technical committee and must be reviewed every five years and if not revised, either reapproved or withdrawn. Your comments are invited either for revision of this standard or for additional standards and should be addressed to ASTM Headquarters. Your comments will receive careful consideration at a meeting of the responsible technical committee, which you may attend. If you feel that your comments have not received a fair hearing you should make your views known to the ASTM Committee on Standards, 100 Barr Harbor Drive, West Conshohocken, PA 19428.

 **C 964**

This standard is copyrighted by ASTM, 100 Barr Harbor Drive, West Conshohocken, PA 19428-2959, United States. Individual reprints (single or multiple copies) of this standard may be obtained by contacting ASTM at the above address or at 610-832-9585 (phone), 610-832-9555 (fax), or service@astm.org (e-mail); or through the ASTM website (<http://www.astm.org>).