



Standard Test Method for Extrudability of Oil- and Resin-Base Caulking Compounds¹

This standard is issued under the fixed designation D 2452; the number immediately following the designation indicates the year of original adoption or, in the case of revision, the year of last revision. A number in parentheses indicates the year of last reapproval. A superscript epsilon (ϵ) indicates an editorial change since the last revision or reapproval.

1. Scope

1.1 This test method describes the laboratory procedure for determining the rate of extrusion of oil- and resin-base caulking compounds.

1.2 The values stated in metric (SI) units are to be regarded as the standard. The values given in parentheses are provided for information only.

1.3 The subcommittee with jurisdiction is not aware of any similar ISO standard.

1.4 *This standard does not purport to address all of the safety concerns, if any, associated with its use. It is the responsibility of the user of this standard to establish appropriate safety and health practices and determine the applicability of regulatory limitations prior to use.*

2. Referenced Documents

2.1 *ASTM Standards:*

C 717 Terminology of Building Seals and Sealants²

D 1475 Test Method for Liquid Coatings, Inks, and Related Products³

3. Terminology

3.1 *Definitions*—Definitions of the following terms are found in Terminology C 717: caulking compound, compound, sealant.

4. Significance and Use

4.1 The rate of extrusion determined by this test may be correlated with the rate of gunning of the compound.

5. Apparatus

5.1 *Press-Flow Extrusion Rheometer* constructed in accordance with Fig. 1.

5.2 *Air Supply and Pressure Gage*, accurate to 6.9 kPa (1 psi).

5.3 *Clamps and Stand* to hold rheometer.

5.4 *Balance*, accurate to 0.01 g.

5.5 *Stop Watch*.

5.6 *Spatula (Steel)*.

5.7 *Weight-per-gallon Cup*, capacity 83.2 cm³.

6. Reagent

6.1 *Solvent*, such as methyl ethyl ketone.

7. Sampling

7.1 The compound to be tested shall be taken from a previously unopened container and thoroughly mixed before using.

8. Conditioning

8.1 After thoroughly cleaning the press-flow rheometer with solvent, condition the compound and the rheometer in the laboratory for at least 5 h at $23 \pm 2^\circ\text{C}$ ($73.4 \pm 3.6^\circ\text{F}$).

9. Procedure

9.1 Remove the orifice holder from the rheometer cylinder and hold the open end up, making sure that the follower plate remains inside.

9.2 Fill the cylinder with compound, avoiding air pockets. Strike off the filled cylinder with a spatula and replace the bottom orifice cap. Connect the tube to an air supply and fix it to a support stand above the balance.

9.3 Adjust the air pressure to 207 kPa (30 psi) and open the air valve. If the pressure drops, readjust to 207 kPa while extrusion is in progress. Close the air valve and discard this extruded compound. The apparatus is now ready for testing.

9.4 Open the air valve and start the stop watch simultaneously. After extruding approximately 50 g of compound, close the air valve and stop the stop watch simultaneously. Weigh to the nearest 0.01 g the amount of compound extruded.

9.5 Calculate the seconds per gram by dividing the number of seconds elapsed by the number of grams extruded, and designate this as value *S*.

9.6 Convert the value *S* to seconds per millilitre after determining the specific gravity of the compound using the weight-per-gallon cup and Test Method D 1475.

¹ This test method is under the jurisdiction of ASTM Committee C24 on Building Seals and Sealants, and is the direct responsibility of Subcommittee C24.20 on General Sealant Standards.

Current edition approved May 10, 2003. Published June 2003. Originally approved in 1966. Last previous edition approved in 1999 as D 2452 – 94 (1999) ^{ϵ 1}.

² *Annual Book of ASTM Standards*, Vol 04.07.

³ *Annual Book of ASTM Standards*, Vol 06.01.

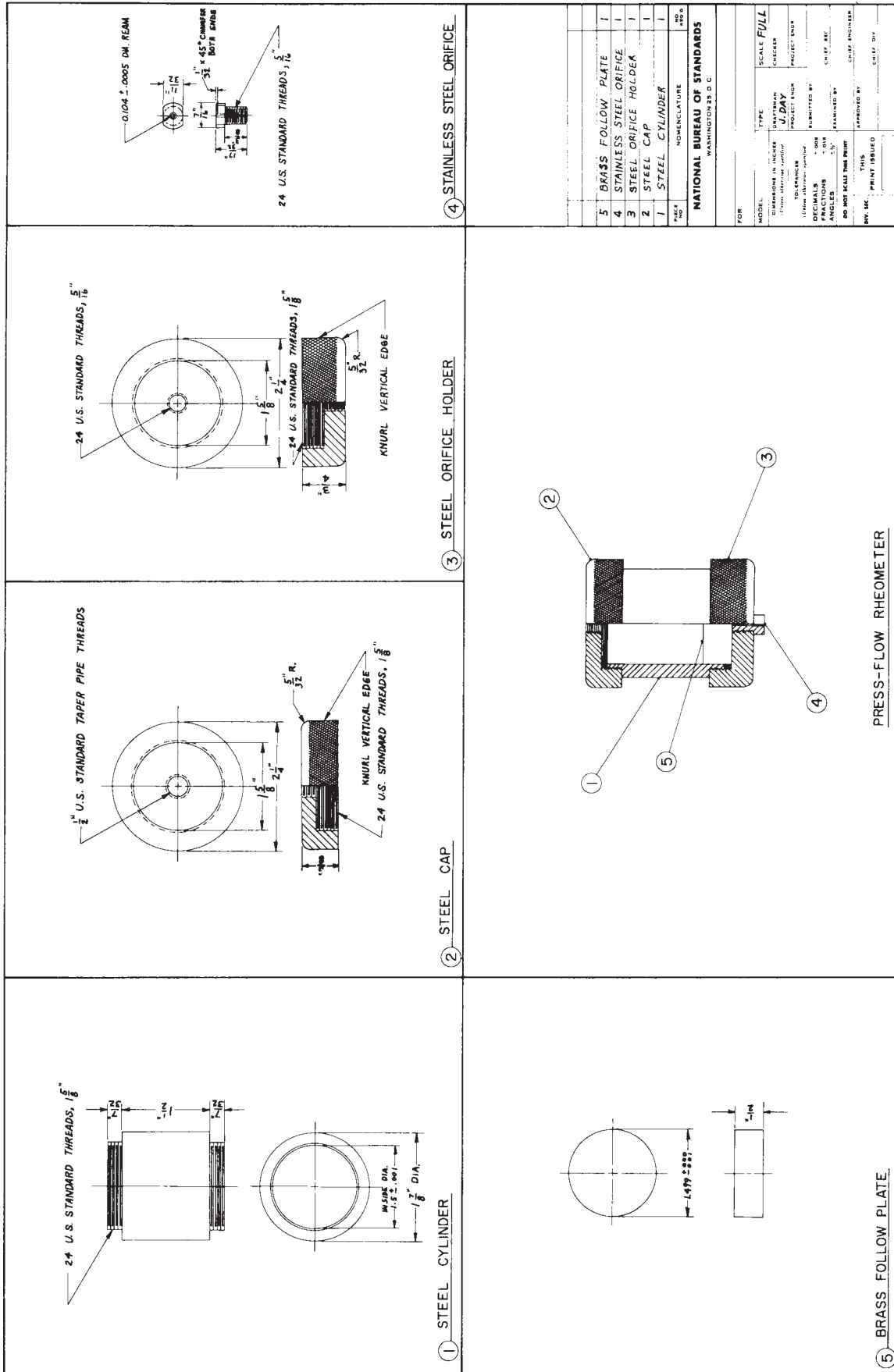

FIG. 1 Press-Flow Extrusion Rheometer

NOTE 1—Since different compounds have different specific gravities, and the extrusion rate in terms of volume normally is of greater interest than in terms of weight, the results shall be converted to terms of seconds per millilitre.

10. Specific Gravity

- 10.1 Weigh the weight-per-gallon cup accurately to 0.1 g.
- 10.2 Remove the cover and fill to within 2.5 mm (0.1 in.) of the brim with compound.
- 10.3 Carefully replace the cover so that air and excess material are expelled through the vent. Wipe the cover to remove surplus and reweigh.
- 10.4 By subtraction, determine the weight (grams) of contents. The net weight of the sample in grams, divided by 10, is the weight per gallon in pounds.

11. Calculation

11.1 Calculate the extrudability, E , in seconds per millilitre, as follows:

$$E = S \times D \quad (1)$$

where:

S = seconds per gram, and

D = specific gravity = weight/gallon (in pounds) \times 0.12.

12. Report

12.1 Report the extrudability, in seconds per millilitre.

13. Precision and Bias

13.1 On the basis of a round-robin in which six laboratories tested six samples covering a range of extrudability values, the “between-laboratories” coefficient of variation was found to be 16.7 %. Based on this value of the coefficient of variation, the following criteria should be used for judging the acceptability of results at the 95 % confidence level:

13.1.1 *Repeatability*—No data at the present time.

13.1.2 *Reproducibility*—Two results obtained by operators in different laboratories should be considered suspect if they differ by more than 60 % of the mean value.

14. Keywords

14.1 caulking compounds; extrudability; gunnability

ASTM International takes no position respecting the validity of any patent rights asserted in connection with any item mentioned in this standard. Users of this standard are expressly advised that determination of the validity of any such patent rights, and the risk of infringement of such rights, are entirely their own responsibility.

This standard is subject to revision at any time by the responsible technical committee and must be reviewed every five years and if not revised, either reapproved or withdrawn. Your comments are invited either for revision of this standard or for additional standards and should be addressed to ASTM International Headquarters. Your comments will receive careful consideration at a meeting of the responsible technical committee, which you may attend. If you feel that your comments have not received a fair hearing you should make your views known to the ASTM Committee on Standards, at the address shown below.

This standard is copyrighted by ASTM International, 100 Barr Harbor Drive, PO Box C700, West Conshohocken, PA 19428-2959, United States. Individual reprints (single or multiple copies) of this standard may be obtained by contacting ASTM at the above address or at 610-832-9585 (phone), 610-832-9555 (fax), or service@astm.org (e-mail); or through the ASTM website (www.astm.org).