



Designation: D 2453 – 9903

Standard Test Method for Shrinkage and Tenacity of Oil- and Resin-Base Caulking Compounds¹

This standard is issued under the fixed designation D 2453; the number immediately following the designation indicates the year of original adoption or, in the case of revision, the year of last revision. A number in parentheses indicates the year of last reapproval. A superscript epsilon (ϵ) indicates an editorial change since the last revision or reapproval.

1. Scope

1.1 This test method describes a laboratory procedure for determining the shrinkage of oil- and resin-base (Note) caulking compounds, as well as the evaluation of the tenacity property of such compounds. This test method is applicable to both gun (Type I) and knife (Type II) grades.

NOTE 1—This is not a suitable test method for water-base products.

1.2 The values stated in SI units are to be regarded as the standard. The values given in parentheses are for information only.

1.3 The subcommittee with jurisdiction is not aware of any similar ISO standard.

1.4 *This standard does not purport to address all of the safety concerns, if any, associated with its use. It is the responsibility of the user of this standard to establish appropriate safety and health practices and determine the applicability of regulatory limitations prior to use.*

2. Referenced Documents

2.1 *ASTM Standards:*

¹ This method is under the jurisdiction of ASTM Committee C24 on Building Seals and Sealants, and is the direct responsibility of Subcommittee C24.20 on General Sealant Standards.

Current edition approved Feb. 10, 1999; 2003. Published April 1999; June 2003. Originally published as D 2453 – 66 T; approved in 1966. Last previous edition approved in 1999 as D 2453 – 94 ϵ .

3. Terminology

3.1 *Definitions*—Definitions of the following terms are found in Terminology C 717: caulking, caulking compound, compound, cure, joint.

4. Summary of Test Method

4.1 A ¼-in. layer of caulking compound is aged 120 h at 65 ± 2°C (149 ± 3.6°F) and its shrinkage is determined by comparing its initial volume to the volume after the aging period.

4.2 After the shrinkage has been determined, this same specimen is also used to test tenacity by folding the aged material 180° six times.

5. Significance

5.1 Shrinkage is a measure of the nonvolatile solids of an oil- or resin-base compound. A compound that exhibits excessive shrinkage may have a tendency to crack or shink from the sides of a joint when in service.

5.2 Tenacity is the measure of the flexibility of an oil- or resin-base caulking compound. Oil- or resin-base caulking compounds that cure excessively hard and do not remain flexible may fail prematurely because of the inability to absorb movement.

6. Apparatus and Materials

6.1 *Cabinet or Room*, capable of maintaining a temperature of 23 ± 2°C (73.4 ± 3.6°F) at 50 ± 5 % relative humidity for extended periods of time.

6.2 *Oven* (convection-type), controlled at 65 ± 2°C (149 ± 3.6°F).

6.3 *Oven* (convection- or blower-type), controlled at 104 ± 2°C (220 ± 3.6°F).

6.4 *Titration Buret*, 50-mL capacity, marked in 0.1 mL.

6.5 *Brass Ring*, metal, 0.8 to 3.2 mm (1/32 to 1/8 in.) thick; inside diameter, 66.7 mm (2 5/8 in.); and 12.7 mm (1/2 in.) wide, with ends of the ring ground flat.

6.6 *Cover Plates*, ground glass, two, 76 to 89 mm (3 to 3 1/2 in.) in diameter.

6.7 *Limestone Block*, standard 89 mm (3 1/2 in.) square by 16 to 19 mm (5/8 to 3/4 in.) thick.

6.8 *Steel Spatula or Putty Knife* about 102 mm (4 in.) long and about 19 mm (3/4 in.) wide.

6.9 *Leveling Tool* for spreading compound (Fig. 1).

6.10 *Knife*, thin-pointed blade.

6.11 *Putty Knife*, steel, stiff, about 102 mm (4 in.) long and about 51 mm (2 in.) wide at the end.

6.12 *Distilled Water*.

7. Sampling

7.1 The compound to be tested shall be taken from a previously unopened container. Remove the compound from the container and work with a putty knife to a homogeneous consistency on a nonporous surface.

8. Conditioning

8.1 Condition limestone blocks in an oven at 104 ± 2°C (220 ± 3.6°F) for 24 h and then cool to room temperature.

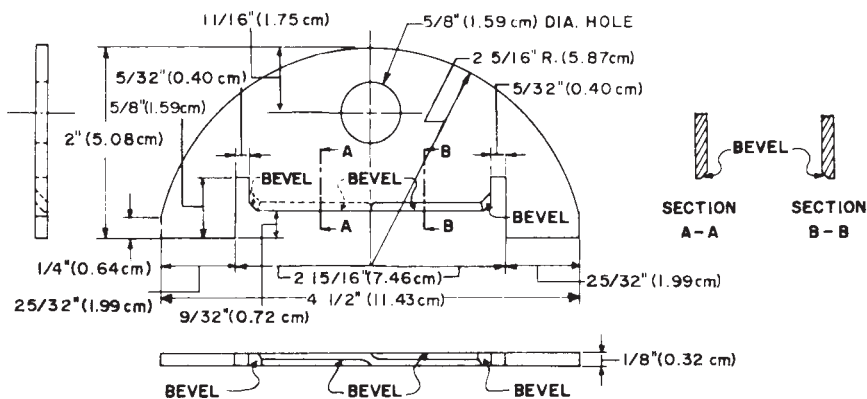

FIG. 1 Tool for Leveling Caulking Compound in the Shrinkage Test Specimen

² Annual book of ASTM Standards, Vol 04.07.

8.2 Condition the unopened cartridge or can of caulking compound for at least 5 h at $23 \pm 2^\circ\text{C}$ ($73.4 \pm 3.6^\circ\text{F}$).

9. Procedure for Shrinkage Determination

9.1 Place the brass ring on one of the ground-glass plates. Determine the volume of the ring by filling it with distilled water at $23 \pm 2^\circ\text{C}$ ($73.4 \pm 3.6^\circ\text{F}$), from a titrating buret. Pour the water slowly from the buret into the ring so that there are no air bubbles visible when the glass cover plate is centered on top of the ring. Record the amount of water required to fill the ring to the nearest 0.03 mL, as V_r .

9.2 Center the ring on the limestone block. Spread a 6-mm ($1/4$ -in.) layer of compound in the ring, using the leveling tool to form good contact with ring and stone (Fig. 1). The leveling tool should fit firmly against the inside surface of the ring while the tool is rotated. Pour distilled water from the buret into the ring until it is exactly filled (without air bubbles), as determined by covering with a ground-glass plate (Fig. 2). Record the quantity of water needed to fill the ring (reading the buret to an accuracy of 0.03 mL) and designate the amount as V_i .

9.3 Pour out the water from the ring and place the specimen, at the same level as the temperature measuring device, in an oven set at $65 \pm 2^\circ\text{C}$ ($149 \pm 3.6^\circ\text{F}$) for 120 h. At the end of this exposure period and after the specimen has cooled for 2 h at room temperature, repeat the filling of the ring using the buret and record the volume of water used as V_f .

10. Calculation

10.1 Calculate the shrinkage, in volume percent, as follows:

$$\text{Shrinkage, \%} = [(V_f - V_i)/(V_r - V_i)] \times 100 \tag{1}$$

where:

V_r = volume of ring, mL,

V_f = volume of water required to fill ring after 120 h exposure, and

V_i = volume of water required to fill ring before oven exposure.

11. Procedure for Tenacity Determination

11.1 After the shrinkage determination has been completed, run the point of the knife blade along the inside edge of the ring and lift the ring from the compound and the block. With the stiff putty knife, loosen one half of the caulking pat from the block. Place the putty knife under the loosened portion of the compound and fold over 180° onto the remaining part of the compound, return to the original position, and repeat the operation until six folds have been made along the same line. Embrittlement or lack of tenacity is indicated by breaking or cracking of the caulking layer at the crease.

12. Report

12.1 *Shrinkage*— Report the percent of volume shrinkage.

12.2 *Tenacity*— Report as pass or fail; passage requires a minimum of six folds.

13. Precision and Bias

13.1 *Shrinkage*— On the basis of a round robin in which eight laboratories tested two samples, the “between-laboratories” standard deviation of the amount of shrinkage, expressed in percent, by volume, was found to be 1.10. Based on this value of the standard deviation, the following criteria should be used for judging the acceptability of results at the 95 % confidence level:

13.1.1 *Repeatability*—No data at the present time.

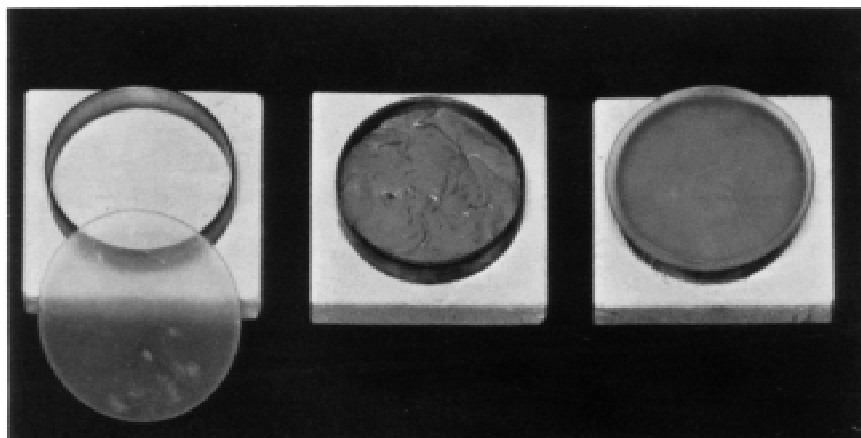

FIG. 2 Stages in the Shrinkage Test Procedure

13.1.2 *Reproducibility*—Two results obtained by operators in different laboratories should be considered suspect if they differ by more than 3.8 percentage points.

13.2 *Tenacity*:

13.2.1 On the basis of a round robin in which eight laboratories tested two samples in a “pass-fail” test, there was a unanimous agreement among all the participant laboratories on the two samples tested.

13.2.2 *Repeatability*—No data at the present time.

14. Keywords

14.1 caulking compound; flexibility; shrinkage

ASTM International takes no position respecting the validity of any patent rights asserted in connection with any item mentioned in this standard. Users of this standard are expressly advised that determination of the validity of any such patent rights, and the risk of infringement of such rights, are entirely their own responsibility.

This standard is subject to revision at any time by the responsible technical committee and must be reviewed every five years and if not revised, either reapproved or withdrawn. Your comments are invited either for revision of this standard or for additional standards and should be addressed to ASTM International Headquarters. Your comments will receive careful consideration at a meeting of the responsible technical committee, which you may attend. If you feel that your comments have not received a fair hearing you should make your views known to the ASTM Committee on Standards, at the address shown below.

This standard is copyrighted by ASTM International, 100 Barr Harbor Drive, PO Box C700, West Conshohocken, PA 19428-2959, United States. Individual reprints (single or multiple copies) of this standard may be obtained by contacting ASTM at the above address or at 610-832-9585 (phone), 610-832-9555 (fax), or service@astm.org (e-mail); or through the ASTM website (www.astm.org).