



Standard Test Method for Flammability of Marine Surface Finishes¹

This standard is issued under the fixed designation E 1317; the number immediately following the designation indicates the year of original adoption or, in the case of revision, the year of last revision. A number in parentheses indicates the year of last approval. A superscript epsilon (ϵ) indicates an editorial change since the last revision or reapproval.

1. Scope

1.1 This fire-test-response standard covers a procedure for measuring fire properties associated with flammable behavior of surface finishes used on noncombustible substrates aboard ship (Note 1). In particular, these include surface finishes intended for use in ship construction such as deck surfacing materials, bulkhead and ceiling veneers including any adhesives used to fasten the veneers to the bulkheads and ceilings, paints, and exposed treatment of insulating materials.

NOTE 1—This test method has been prepared to closely follow the test procedure of IMO Resolution A.653(16) (1).² Optional provisions not applicable to the domestic use of this test method have been deleted.

1.2 Tests performed according to this test method are intended to yield fire properties that, when appropriately interpreted, are potentially useful to select materials and surface treatments that will limit the rapid growth and spread of fire.

1.3 This test method requires a specific range of specimen radiant thermal exposure for measuring fire properties.

1.4 *This standard is used to measure and describe the response of materials, products, or assemblies to heat and flame under controlled conditions, but does not by itself incorporate all factors required for fire hazard or fire risk assessment of the materials, products, or assemblies under actual fire conditions.*

1.5 *This standard does not purport to address all of the safety concerns, if any, associated with its use. It is the responsibility of the user of this standard to establish appropriate safety and health practices and determine the applicability of regulatory limitations prior to use.* For specific hazard statements, see Section 7.

2. Referenced Documents

2.1 ASTM Standards:

E 84 Test Method for Surface Burning Characteristics of Building Materials³

E 162 Test Method for Surface Flammability of Materials Using a Radiant Heat Energy Source³

E 176 Terminology of Fire Standards³

E 286 Test Method for Surface Flammability of Building Materials Using an 8-ft (2.44-m) Tunnel Furnace⁴

E 648 Test Method for Critical Radiant Flux of Floor-Covering Systems Using a Radiant Heat Energy Source³

E 970 Test Method for Critical Radiant Flux of Exposed Attic Floor Insulation Using a Radiant Heat Energy Source³

E 1321 Test Method for Determining Material Ignition and Flame Spread Properties³

2.2 *Code of Federal Regulations (CFR):*

CFR Title 46, Part 164.009, Noncombustible Materials⁵

2.3 *ASTM Adjuncts:* ASTM

Detailed drawings (19), construction information, and parts list (Adjunct to E1317)⁶

3. Terminology

3.1 *Definitions*—For definitions of general terms used in this test method, refer to Terminology E 176.

3.2 *Definitions of Terms Specific to This Standard:*

3.2.1 *compensating thermocouple, n*—a thermocouple for the purpose of generating an electrical signal representing long-term changes in the stack metal temperatures wherein a fraction of the signal generated is subtracted from the signal developed by the stack-gas thermocouples.

3.2.2 *critical flux at extinguishment, n*—a flux level at the specimen surface corresponding to the distance of farthest advance and subsequent self-extinguishment of the flame on the centerline of a specimen.

3.2.2.1 *Discussion*—The flux reported is based on calibration tests with a special calibration dummy specimen.

3.2.3 *dummy specimen*—a noncombustible (as defined by 46 CFR 164.009) specimen used for standardizing the operating condition of the equipment, roughly 20 mm in thickness with a density of $750 \pm 100 \text{ kg/m}^3$.

3.2.4 *fume stack*—a box-like duct with thermocouples and baffles through which flames and hot fumes from a burning

¹ This test method is under the jurisdiction of ASTM Committee E05 on Fire Standards and is the direct responsibility of Subcommittee E05.22 on Surface Burning.

Current edition approved June 10, 1997. Published August 1997. Originally published as E 1317 – 90. Last previous edition E 1317 – 97.

² The boldface numbers in parentheses refer to a list of references at the end of this standard.

³ *Annual Book of ASTM Standards*, Vol 04.07.

⁴ Discontinued; see *1992 Annual Book of ASTM Standards*, Vol 04.07.

⁵ Available from Superintendent of Documents, U.S. Government Printing Office, Washington, DC 20402.

⁶ Detailed drawings are available from ASTM Headquarters. Request ADJE1317.

specimen pass whose purpose is to permit measurement of the heat release from the burning specimen.

3.2.5 *heat for ignition*—the product of time from initial specimen exposure until the flame front reaches the 150-mm position and the flux level at this position, the latter obtained in prior calibration of the apparatus.

3.2.6 *heat for sustained burning*—the product of time from initial specimen exposure until the arrival of the flame front, and the incident flux level at that same location as measured with a dummy specimen during calibration.

3.2.7 *marine board*—an insulation board of 750 ± 100 kg/m³ density that meets the noncombustibility criteria of 46 CFR 164.009.

3.2.8 *measured heat release of specimen*—the observed heat release under the variable flux field imposed on the specimen and measured as defined by this test method.

3.2.9 *mirror assembly*—a mirror, marked and aligned with the viewing rakes, used as an aid in quickly identifying and tracking the flame front progress.

3.2.10 *reverberatory wires*—a wire mesh located in front of, but close to, the radiating surface of the panel heat source which serves to enhance the combustion efficiency and increase the radiance of the panel.

3.2.11 *special calibration dummy specimen*—a dummy specimen as defined by Fig. 1, made of the same material as the dummy specimen, intended only for use in calibration of flux gradient along the specimen.

3.2.12 *viewing rakes*—a set of bars with wires spaced at 50-mm intervals for the purpose of increasing the precision of timing the flame front progress along the specimen.

4. Summary of Test Method

4.1 This test provides methods for evaluating the flammability characteristics of 155 by 800-mm specimens in a vertical orientation. The specimens are exposed to a graded radiant-flux field supplied by a gas-fired radiant panel. Means are provided for observing the times to ignition, spread, and extinguishment of flame along the length of the specimen as well as for measuring the compensated millivolt signal of the stack gas thermocouples as the burning progresses. Results are reported

in terms of heat for ignition, heat for sustained burning, critical flux at extinguishment, and heat release of the specimen during burning.

5. Significance and Use

5.1 This test method provides a means for evaluation of the flammable performance of surface finish materials used in constructing and outfitting ships.

5.2 A specimen of the surface finish of concern is mounted on the support material contemplated for use and subjected to a controlled significant radiant-flux exposure.

5.3 All specimens are tested while mounted in a vertical plane.

5.4 The following surfaces are exposed to test:

5.4.1 Bulkhead specimens having surface veneers, fabrics, or painted finishes are tested on one or both exposed sides.

5.4.2 Ceiling finish materials shall be tested on the lower exposed surface.

5.4.3 For ceiling finish materials which are perforated and air backed, tests also shall be conducted on the back (upper) surface of the material.

5.4.4 Deck finish and flooring materials are tested on the upper exposed surface.

5.4.5 Protective membranes or finishes on insulation materials are tested on the air-exposed face or faces.

5.5 This test method provides fire properties that relate to the flammability of the specimens tested. These include ignitability, heat exposure for continued burning, critical flux at extinguishment, and heat-release behavior under varying flux-exposure conditions applied.

5.6 This test method does not provide:

5.6.1 Full information on fire properties of surface-finish materials supported by backing materials other than those tested.

5.6.2 Full information on surface-finish materials when used in other thicknesses than those tested.

5.6.3 Methods for using the fire property measurements as a measure for classifying the fire risk or hazard of the specimens tested.

6. Apparatus

6.1 *Test Equipment*— Figs. 2-6 show photographs of the equipment as assembled ready for test. Detailed drawings and a parts list are available from ASTM.⁶ These provide engineering information necessary for the fabrication of the main frame, specimen holders, stack, and other parts of the equipment. Some commercially available units have added safety features that are not described in the drawings. Brief parts list for the test equipment assembly includes:

6.1.1 *Main Frame* (see Fig. 2(a) and Fig. 2(b) consisting of two separate sections; the burner frame and the specimen support frame. These two units are bolted together with threaded rods permitting flexibility in mechanical alignment.

6.1.2 *Specimen Holders* that provide for support of the specimen during test. At least two of these are required. Using three of these will prevent delays resulting from required cooling of holders prior to mounting specimens.

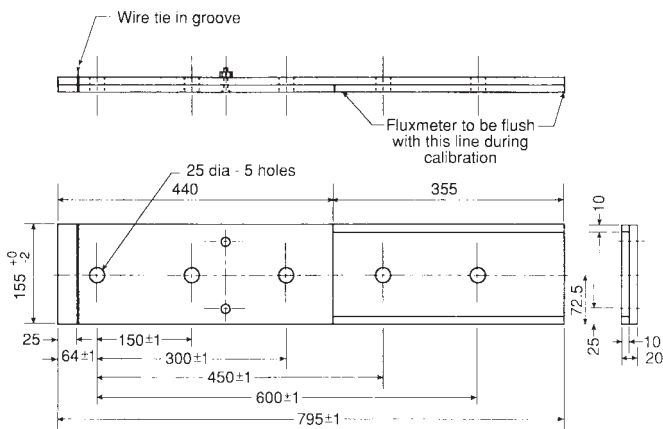

NOTE 1—All dimensions are in millimetres.

FIG. 1 Dummy Specimen for Flux Gradient Calibration



FIG. 2 (a) General View of the Apparatus

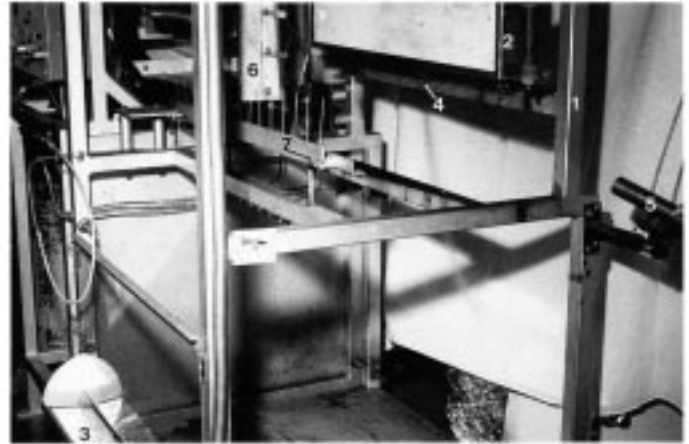

- 1—Specimen support frame
- 2—Specimen holder
- 3—Flame-front viewing mirror
- 4—Viewing rake
- 5—Radiation pyrometer
- 6—Radiant panel assembly
- 7—Viewing rake for horizontal specimen not used in this test method

FIG. 3 View From Specimen Insertion Frame



FIG. 4 Radiant Panel Facing Dummy Specimen

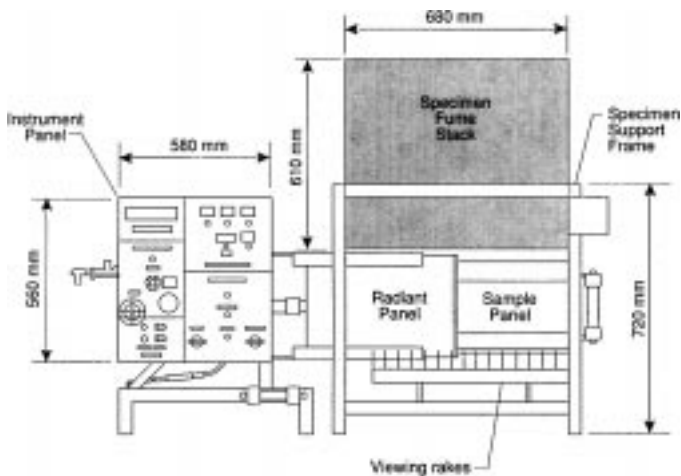

FIG. 2 (b) Test Apparatus Main Frame, Front View (continued)

6.1.3 *Specimen Fume Stack*, fabricated of stainless sheet steel of 0.46 ± 0.05 mm thickness (see Fig. 7) complete with gas and stack-metal compensating thermocouples (also see Fig. 5).

6.1.4 *Radiant Panel (2)* (see Fig. 4) shall have heated surface dimensions of 280 by 483 mm. The radiant panel consists of an enclosure supporting porous refractory tiles.

6.1.5 *Air and Fuel Supply*—An air and fuel supply to support combustion on the radiant panel surface, air-flow metering device, gas-control valves, pressure reducer and safety controls are all mounted on the burner frame. Requirements are summarized as follows:

6.1.5.1 A regulated air supply of about $30 \text{ m}^3/\text{h}$ at a pressure sufficient to overcome the friction loss through the line, metering device, and radiant panel (Note 2). The radiant panel pressure drop amounts to only a few millimetres of water.

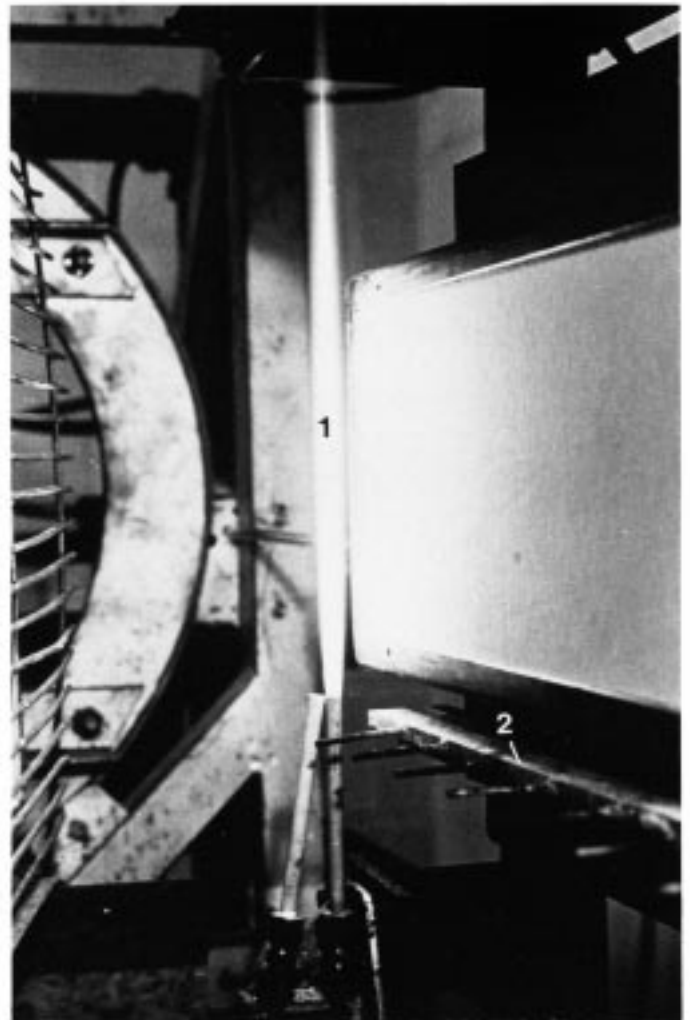

FIG. 5 Rear View of Specimen Supported in Equipment Showing Specimen Clamp, Stack and Handle of Stack Thermocouple Assembly

NOTE 2—In the absence of a calibrated flowmeter in the air line this flow rate can be roughly set by holding a lighted match with its axis horizontal and close to the panel tile face. The match flame should deviate from the vertical by about 10°.

6.1.5.2 The fuel gas used shall be either natural gas or methane. A pressure regulator shall be provided to maintain a constant supply pressure. The gas shall be controlled either by a manually adjusted needle valve or a venturi mixer. The venturi mixer will allow control of the flux level of the panel by adjusting only the air valve. Safety devices shall include an electrically operated shutoff valve to prevent gas flow in the event of electric power failure, air pressure failure, or loss of heat at the burner surface. The fuel gas flow requirements shall be 1.0 to 3.7 m³/h at a pressure sufficient to overcome pressure losses.

6.1.6 The specimen holder, pilot-flame holder, fume stack, flame-front viewing rakes, radiation pyrometer, and mirror are all assembled on the specimen support frame. The arrangement of parts on this frame is evident in Fig. 2(a), Fig. 2(b), and Fig. 3.



1—Pilot flame
2—Viewing rake

NOTE 1—Two burners are provided; only one for the non-contracting pilot is operating.

FIG. 6 Pilot Flame and Dummy Assembly

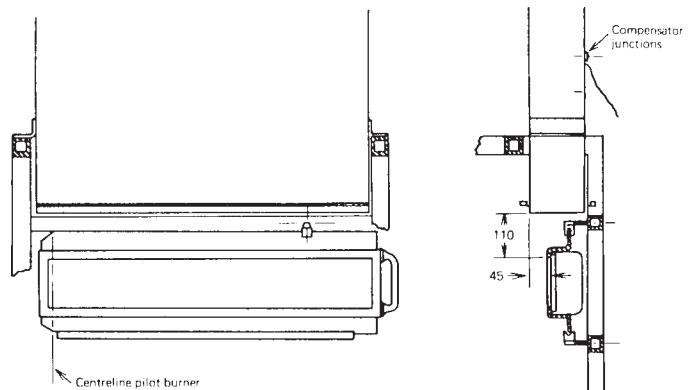

FIG. 7 Stack—Specimen Position Dimensions



6.1.7 A dummy specimen of marine board of the thickness and density specified in the test procedure shall be mounted on the apparatus in the position of the specimen except during actual testing.

6.2 Instrumentation:

6.2.1 *Total Radiation Pyrometer*—This instrument shall be compensated for its temperature variation and shall have a sensitivity between the thermal wavelengths of 1 and 9 μm that is nominally constant and shall view a centrally located area on the radiant panel of about 150 by 300 mm. The instrument shall be rigidly mounted on the specimen support frame in such a manner that it will be directed at the radiant panel surface oriented for specimens in the vertical positions.

6.2.2 *Heat Fluxmeters*—It is desirable to have at least two fluxmeters for this test method. They shall be of the thermopile type with a sensitivity of approximately 10 mV at 50 kW/m² and capable of operation at three times this rating. One of these shall be retained as a laboratory reference standard. They shall have been calibrated to an accuracy of $\pm 5\%$ or better. The time constant of these instruments shall not be more than 290 ms (corresponding to a time to reach 95 % of final output of not more than 1 s). The target sensing the applied flux shall occupy an area not more than 4 by 4 mm and be located flush with and at the center of the water cooled 25 mm circular exposed metallic end of the fluxmeter. If fluxmeters of smaller diameter are to be used, these shall be inserted into a copper sleeve of 25 mm outside diameter in such a way that good thermal contact is maintained between the sleeve and water cooled fluxmeter body. The end of the sleeve and exposed surface of the fluxmeter shall lie in the same plane. Radiation shall not pass through any window before reaching the fluxmeter sensing surface.

6.2.3 *Timing Devices*, such as either a paper tape chronograph, as well as digital clock with second resolution, digital stopwatch with a memory for ten times, an audio tape recorder, a data acquisition/computer system, or an audio visual (VCR) instrument shall be provided to measure the times of ignition and flame front advancement with resolution to $\frac{1}{10}$ s.

6.2.4 *Recording Millivoltmeter*—A two-channel multirange recording millivoltmeter having at least 1 M Ω input resistance shall be used to record signals from the fume stack thermocouples (see Fig. A1.3) and the output from the radiation pyrometer. The signal from the fume stack will in most instances be less than 15 mV. The sensitivity of the other channel shall be selected to require less than full scale deflection with the total radiation pyrometer or fluxmeter chosen. The effective operating temperature of the radiant panel will not normally exceed 935°C. Either the two-channel multi-range recording millivoltmeter or a digital millivoltmeter with a resolution of 10 μV or less shall be used for monitoring changes in operating conditions of the radiant panel.

6.3 Space for Conducting Tests:

6.3.1 *Test Area*—The dimensions of the test area shall be at least 45 m³ volume with a ceiling height of not less than 2.5 m.

6.3.2 *Fume Exhaust System*—An exhaust system shall be installed with a capacity for moving air and combustion products at a rate of 30 m³/min. The exhaust system shall be surrounded by a 1.3 by 1.3 m refractory-fiber fabric skirt

hanging down to 1.7 ± 0.1 m from the floor of the room. The specimen support frame and radiant panel shall be located beneath this hood in such a way that essentially all combustion fumes are withdrawn from the room.

6.3.3 The apparatus shall be located with a clearance of at least 1-m separation between it and the walls of the test room. No combustible finish material of ceiling, floor, or walls shall be located within 2 m of the radiant heat source.

6.3.4 *Air Supply*—Access to an exterior supply of air, to replace that removed by the exhaust system, is required. This shall be arranged in such a way that the ambient temperature remains reasonably stable (for example, the air might be taken from an adjoining heated building).

6.3.5 *Room Draughts*—Measurements shall be made of air speeds near a dummy specimen in the vertical position while the fume exhaust system is operating but the radiant panel and its air supply are turned off. The air flow shall not exceed 0.2 m/s in any direction at a distance of 100 mm perpendicular to the lower edge at midlength of the specimen.

7. Hazards

7.1 Take the following safety precautions:

7.1.1 Safeguards shall be installed in the panel fuel supply to guard against a gas-air fuel explosion in the test chamber. The safeguards shall include, but are not limited to, one or more of the following: a gas feed cutoff activated when the air supply fails; a fire sensor directed at the panel surface to interrupt gas supply if the panel flame is extinguished; or other suitable and approved device. Manual reset is a requirement of any safeguard system used.

7.1.2 The exhaust system shall be so designed that the laboratory environment is protected from smoke and gas. The operator shall be instructed to minimize his exposure to combustion products by following sound safety and industrial hygiene practices, for example, ensure that the exhaust system is working properly, wear appropriate clothing including gloves, wear breathing apparatus when hazardous fumes are expected.

8. Test Specimens

8.1 The samples selected for testing shall be representative of the product as it is intended for use.

8.2 *Specimen Size*—The specimen shall be 155 + 0, – 5 mm wide by 800 + 0, – 5 mm long, and shall be representative of the product.

8.3 *Specimen Thickness*—Materials and composites of normal thickness 50 mm or less shall be tested using their full thickness. For materials and composites of normal thickness greater than 50 mm, obtain the requisite specimens by cutting away the unexposed face to reduce the thickness to 50 + 3, – 0 mm.

8.4 *Number Required*—Test three specimens for each different exposed surface and specimen orientation of the product evaluated.

8.5 *Composites*—Assemblies shall be as specified in 8.3. However, where thin materials or composites are used, it is possible that the presence of an air gap or the nature of any underlying construction, or both, significantly affects the flammability characteristics of the exposed surface. Care shall be

taken to ensure that the test result obtained on any assembly is relevant to its use in practice. For comparison of the relative performance of surface treatments without consideration of the particular backing to which they are likely to be applied, they shall be tested on 10 to 21-mm marine board backing of $750 \pm 100 \text{ kg/m}^3$ density.⁶

9. Calibration of Apparatus

9.1 Perform mechanical, electrical, and thermal calibrations as described in Annex A1. Perform these adjustments and calibrations following initial installation of the apparatus and at other times as the need arises.

9.2 *Monthly Verification*—In a continuing program of tests, the flux distribution shall be determined not less than once a month. When the time interval between tests is greater than one month, the flux distribution shall be determined at the start of the test series.

9.3 *Daily Verification*—Perform the following tests on a daily basis.

9.3.1 *Adjustment of the Pilot Burner*— Adjust the acetylene and air supply to provide a flame length of about 230 mm (see Fig. 8). When this has been done, the flame length as viewed in a darkened laboratory will be seen to extend about 40 mm above the upper retaining flange of the specimen holder. Adjust the space between the burner and the specimen while the radiant source is operating using softwood splines of 3-mm thickness and of 10 and 12-mm width. When these splines are moved along the flame length between the pilot burner flame and a dummy specimen surface during a 2-s exposure, the 10-mm spline shall not be charred but the 12-mm spline shall show char. With the specimen in the vertical position, the charring of the 12-mm spline shall occur over a vertical distance of at least 40 mm from the upper exposed edge of the specimen.

9.3.2 Clean the stack-gas thermocouples by light brushing at least daily. When materials producing heavy soot clouds are tested it is likely that such cleaning will be required even more frequently. Also individually check these thermocouples for electrical continuity to ensure the existence of a useful thermojunction. Following daily cleaning of the parallel connected stack-gas thermocouples, check both the thermocouples and the compensating junction to verify that the resistance between them and the stack metal is in excess of $10^6 \Omega$.

9.4 *Continuous Monitoring of Operation*— A dummy specimen shall remain mounted in the position normally occupied by a specimen whenever the equipment is in stand-by operation. This is a requirement of the continuous monitoring procedure that is accomplished by measuring both stack and millivolt signals from the total radiation pyrometer mounted securely on the specimen holder frame facing the surface of the radiant panel.

9.5 The radiation pyrometer is used for determining that the required thermal operating level has been achieved. The use of the radiation pyrometer permits continuous monitoring of panel operating level even when tests are in progress. The signals shall remain essentially constant for 3 min prior to test. The observed operating level shall correspond, within 2 %, to the similarly measured condition during the calibration procedure mentioned in A1.3.3.

10. Conditioning

10.1 *Specimen Conditioning*—Before testing, condition the specimens to constant moisture content, at a temperature of $23 \pm 3^\circ\text{C}$, and a relative humidity of $50 \pm 5 \%$. Constant moisture content is considered to be reached when, following two successive weighing operations carried out at an interval of 24 h, the measured masses do not differ by more than 0.1 % of the mass of the specimen.

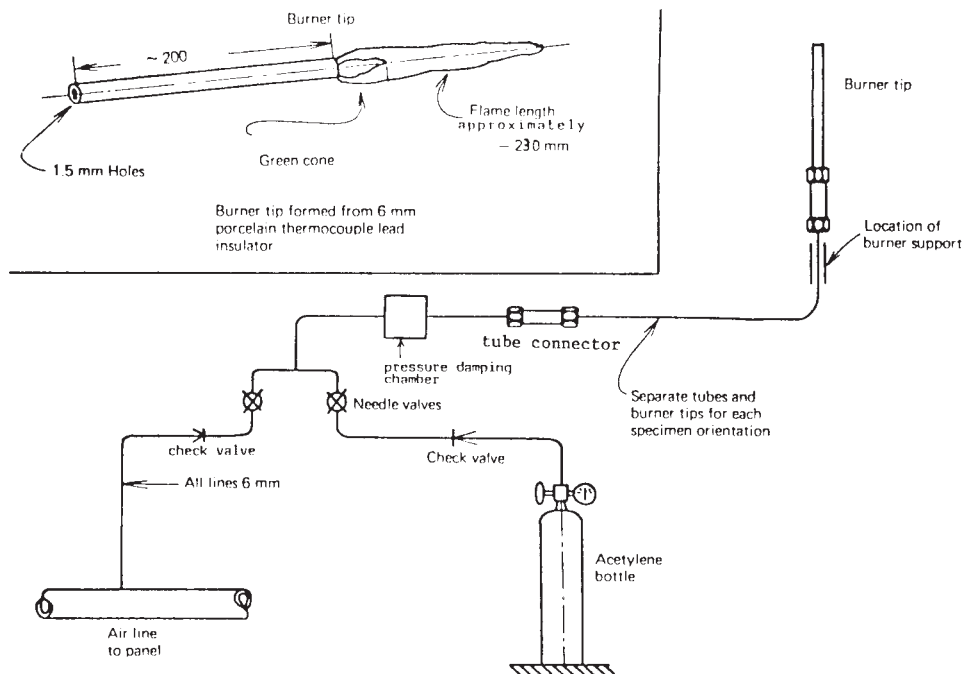

FIG. 8 Pilot Burner Details and Connections

10.2 *Specimen Preparation*—Using a marker such as a soft pencil, draw a line centrally down the length of the exposed face of each specimen. Do not use a marker that will affect specimen performance. Prepare the properly conditioned specimen for test in a cool holder away from the heat of the radiant panel. Prior to insertion in the specimen holder, wrap the back and edges of the specimen in a single sheet of 0.2 mm thick aluminum foil having dimensions of $(175 + a)$ mm by $(820 + a)$ mm, where a is twice the specimen thickness. When inserted in the specimen holder, back each specimen by a cool 10 ± 2 -mm sheet of marine board having the same lateral dimensions and density as the dummy specimen. When mounting nonrigid specimens in the holder, place shims between the specimen and the holder flange to ensure that the exposed specimen face remains at the same distance from the pilot flame as a rigid specimen. For such materials the shims shall only be required for a 100-mm length at the hot end of the specimen.

11. Procedure

11.1 Conduct the test as follows:

11.1.1 Mount the dummy specimen in a specimen holder in position facing the radiant panel. Start the fume-exhaust system.

11.1.2 Adjust the radiant panel to the operating conditions specified in A1.3.2 and A1.3.3.

11.1.3 When both the radiant panel and stack signals have attained equilibrium after the preheat period, light the pilot flame, record both signals for 3 min, and verify continued signal stability.

11.1.4 Remove the dummy specimen holder, and within 10 s insert the specimen in the test position. Immediately start both the clock and chronograph.

11.1.5 Operate the event marker of the chronograph to indicate the time of ignition and arrival of flame front during the initial rapid involvement of the specimen. The time of arrival at a given position is observed as the time at which the flame front at the longitudinal centerline of the specimen coincides with the position of two corresponding wires of the viewing rakes. Record these times manually both from measurements of the chronograph chart and then after the initial rapid flame spread from visual observations of flame position and observation of the clock. Record the arrival of the flame front at each 50-mm position along the specimen. Record both the time and the position on the specimen at which flaming ceases to progress. Record the panel operating level as well as stack signals throughout the test, and continue until test termination.

11.1.6 During the test, make no changes in the fuel supply rate to the radiant panel to compensate for variations in its operating level.

11.1.7 Terminate the test, remove the test specimen, and reinsert the dummy specimen holder when any one of the following conditions occurs:

11.1.7.1 The specimen fails to ignite after a 10-min exposure,

11.1.7.2 Three minutes have passed since all flaming from the specimen ceased, or

11.1.7.3 Flaming reaches the end of the specimen or self-extinguishes and therefore ceases to progress along the specimen. This is applicable only when heat-release measurements are not being made.

11.1.8 Repeat 11.1.1-11.1.6 for two additional specimens.

11.1.9 In the event of failure during testing of one or more specimens, reject such data or perform a new test or tests. Potential sources of failure include, but are not limited to, incomplete observational data or malfunction of the data-logging equipment. It is possible that excessive stack-signal base drift will also require further equipment stabilization and retest.

11.1.10 If the first two specimens do not ignite following a 10 min exposure, test the third specimen with an impinging pilot flame. If this specimen ignites, test two additional specimens with the impinging pilot flame.

11.1.11 If a specimen shows extensive loss of incompletely burned material during the test, test at least one additional specimen, restrained in the test frame with poultry netting. Report the data so obtained separately.

11.1.12 Observe and record the general behavior of the specimen, including glowing, charring, melting, flaming drips, disintegration of the specimen, etc.

12. Report

12.1 Report the following information:

12.1.1 Name and address of the testing laboratory.

12.1.2 Name and address of the manufacturer.

12.1.3 Date of the test.

12.1.4 Description of the product tested including trade name together with its construction, orientation, thickness, density, and, where appropriate, the face subject to test. In the case of specimens that have been painted or varnished, the information recorded shall include the quantity applied as well as the nature of the supporting materials.

12.1.5 Number of specimens tested.

12.1.6 Type of pilot flame used, that is, impinging or nonimpinging.

12.1.7 Duration of each test.

12.1.8 Observations of the burning characteristics of the specimens during the test exposure, such as flashing, unstable flame front, whether or not pieces of burning materials fell off, separations, fissures, sparks, fusion, changes in form, etc.

12.1.9 *Test Results*:

12.1.9.1 Report the results in terms of the thermal measurements of incident flux with a dummy specimen in place. Do not compensate for changes in thermal output of the radiant panel during the conduct of the test.

12.1.9.2 *Heat for Ignition*—List values as defined in 3.2.5.

12.1.9.3 *Heat for Sustained Burning*—List values including averages as defined in 3.2.6, and the average of these values for stations of 150 through 400 mm, measured on the centerline of the specimen.

12.1.9.4 *Critical Flux at Extinguishment*—List values as defined in 3.2.2, and the average of these values.

12.1.9.5 *Heat Release Factors*—List the total heat release, the average total heat release for the specimens tested (Q_{dt}), and the peak heat release (dQ/dt) (see Fig. 9).

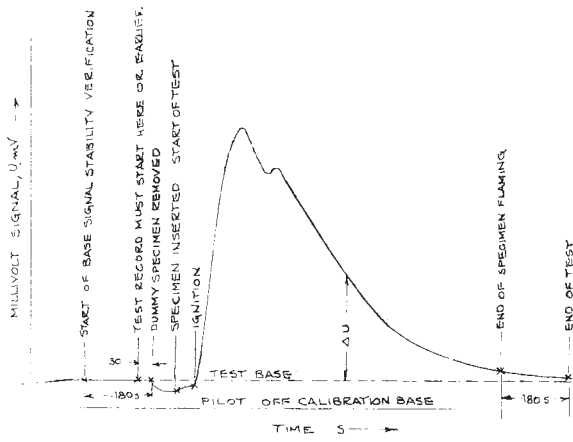

(a) Events Specified and Stack Millivolt Signal Curve Produced During Test

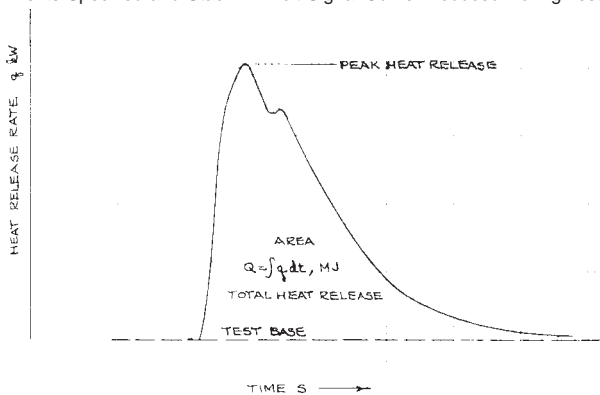

(b) Calculation of Heat Release Curve

NOTE 1— q is heat rate from millivolt signal and derived from calibration curve (b) Calculation of Heat Release Curve.

FIG. 9 Diagrams Showing Method of Deriving Heat Release Curve

13. Precision and Bias ⁷

13.1 Two interlaboratory studies have been conducted on this test method. The first, reported in Ref (3) involved four

countries and ten materials. The data for one of the materials was not included in the analysis because of inadequate testing. This study was limited to flame-spread properties. Values of the coefficient of variation for heat for ignition, critical heat for extinguishment, and heat for continued burning based on three tests of each material were reported. It was found that the average values for all materials in all laboratories were, respectively, 13, 27, and 20 %. Some revisions were made, resulting in the present IMO Resolution A.564(14) (1).

13.2 A second interlaboratory study was conducted with inclusion of the heat-release measurement. The study which involved eleven countries and tests of seven materials was reported by Japan to IMO in Ref (4). Unfortunately, as shown in Ref (5), so many arbitrary deviations were incorporated in the testing, equipment, procedures, and limited reporting of data, that it is impossible to have confidence in the between laboratory analyzed results. However, the within laboratory results exhibit considerable uniformity. Averages of the coefficient of variation in percent for all materials tested and reported by Japan in Ref (4) show values of 9.36, 7.46, 8.04, and 12.37 %. These are for critical flux at extinguishment, heat for ignition, heat for sustained burning, and total heat release, respectively. The statistical calculations made by Japan are somewhat optimistic since n rather than $n - 1$ was used in calculating the standard deviation. These have been corrected by the factor $\sqrt{n/(n - 1)}$, since $n = 3$ becomes 1.225. The resulting average coefficients of variation become 12, 9, 10, and 15 %, respectively.

13.3 This test method incorporates revisions to emphasize specific procedures as well as eliminating an originally optional method of monitoring operating levels of the equipment. The latter had been included in the IMO version to avoid problems some countries might have had in using this test method.

⁷ Supporting data available from ASTM Headquarters. Request RR:E05-1007.

ANNEX

(Mandatory Information)

A1. ASSEMBLY AND CALIBRATION OF APPARATUS

A1.1 Mechanical Adjustment

A1.1.1 With the apparatus assembled as specified in Section 6, make the following mechanical alignments:

A1.1.2 Check the rotating ring to ensure that it lies in a vertical plane. If the bearing does not lie in the vertical plane, adjust the upper support bracket. If any nonvertical position is caused by excessive bearing roller clearance, install larger rollers.

A1.1.3 With the radiant panel rotated into a vertical position (as checked with a level), the angle between the panel and rotating ring, and between the panel and the longitudinal members of the specimen support frame shall be 15° (see Fig. A1.1).

A1.1.4 With an empty specimen holder installed, adjust the upper fork to ensure the holder lies in a vertical plane. Adjust the spacing between the radiant panel and the holder so that

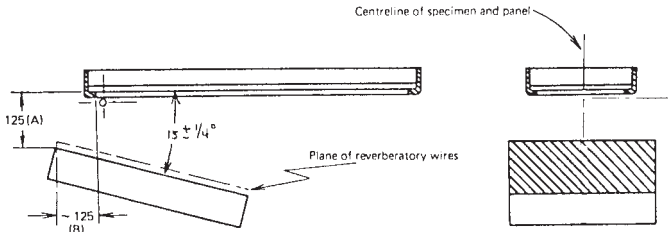

FIG. A1.1 Specimen and Panel Arrangement

Dimension A of Fig. A1.1 is 125 ± 2 mm while still maintaining the $15 \pm \frac{1}{4}^\circ$ angular relationship. The initial spacing of Dimension B shall be 125 mm when required subsequent adjustment of Dimension B is permissible.

A1.1.5 Position the vertical pilot as shown in Fig. A1.2.

A1.1.6 Position the viewing rake so that the pins are located at multiples of 50 ± 2 -mm distance from the closest end of the specimen exposed to the panel.

A1.2 Mechanical Alignment

A1.2.1 The position of the refractory surface of the radiant panel with respect to the specimen must correspond with the dimensions shown in Fig. A1.1. These relationships shall be achieved by adjustment between the panel and its mounting bracket, the two main frames, and the position of the specimen holder guides. Make these adjustments for the specimen in the vertical position. Detailed procedures for making these adjustments are given in A1.1.3 and A1.1.4.

A1.2.2 Position the fume stack for heat release measurements on the specimen support frame in the position shown in Fig. 7, so as to allow for stack removal and cleaning. Mount the compensating thermocouple in such a manner that good thermal contact is achieved while ensuring greater than 1 MΩ electrical resistance from the stack metal wall.

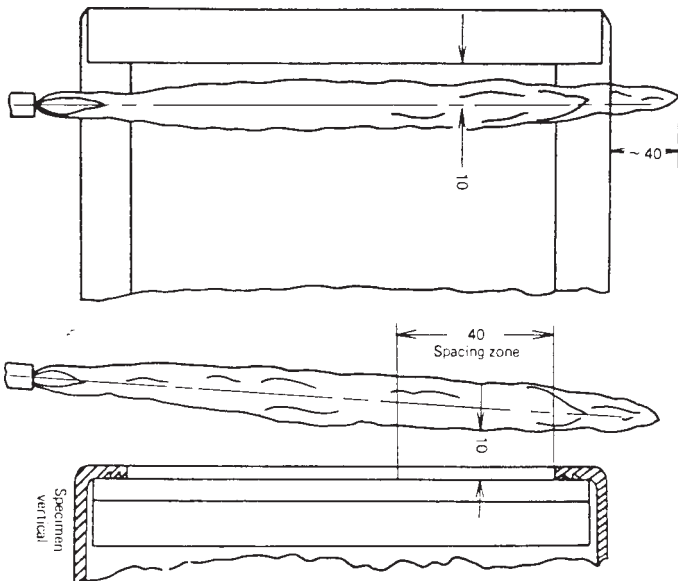

FIG. A1.2 Position of Pilot Flame

A1.3 Thermal Adjustment of Radiant Panel Operating Level

A1.3.1 Thermal adjustment of the panel operating level is achieved by first setting an air flow of about $30 \text{ m}^3/\text{h}$ through the panel (see Note 2). Gas is then supplied and the panel ignited and allowed to come to thermal equilibrium with a dummy specimen mounted before it. At proper operating condition there shall be no visible flaming from the panel surface except when viewed from one side parallel to the panel surface plane. From this direction a thin blue flame very close to the panel surface will be observed. An oblique view of the panel after a 15-min warm-up period shall show a bright orange radiating surface.

A1.3.2 With a water cooled (Note A1.1) fluxmeter mounted in a special dummy specimen (see Fig. 1), the flux incident on the specimen shall correspond to the values shown in Table A1.1. Compliance with this requirement is achieved by adjustment of the air gas flow rates. When required, make changes in air and gas flow to achieve the condition of no significant flaming from the panel surface. In systems using a venturi, the flux levels shall be changed by adjusting only the air valve. Precise duplication of the flux measurements specified in Table A1.1 for the 50 and 350 mm positions on the basis of the fluxmeter calibration used will fix the flux at the other stations well within the limits called for. This does not mean that the measured flux levels are correct, but it does ensure that a fixed configuration or view geometry between the panel and specimen have been achieved. To meet these requirements, make changes in the specimen longitudinal position shown by Dimension B in Fig. A1.1. A plot and smooth curve shall be developed on the basis of the fifteen or at least eight flux

TABLE A1.1 Calibration of Flux to the Specimen

NOTE 1— Listed are typical flux incident on the specimen and specimen positions at which the calibration measurements are to be made. The flux at 50 and 350-mm positions shall be set as accurately as possible. Calibration data at other positions shall agree with typical values within 10%. This calibration shall be performed with the use of the special dummy specimen. It is possible to measure all except the first of the fifteen typical measurements listed with two successive 50-mm withdrawals of the calibration dummy specimen.

Distance from Exposed End of the Specimen, mm	Typical Flux Levels at the Specimen, kW/m ²	Calibration Position to be Used, ^A kW/m ²
0	49.5	
50	50.5	50.5
100	49.5	
150	47.1	X
200	43.1	
250	37.8	X
300	30.9	
350	23.9	23.9
400	18.2	
450	13.2	X
500	9.2	
550	6.2	X
600	4.3	
650	3.1	X
700	2.2	
750	1.5	X

^A An X indicates fluxes at the additional six measuring positions required by the standard. The seven empty spaces represent the fluxes at the additional but not required measuring positions in this test method.

measurements required. The shape of the curve shall be similar to that defined by the typical data shown in Table A1.1. Records of the radiation pyrometer signal shall be kept following successful completion of this calibration procedure. If a change in panel-specimen axial position is required to meet the requirements for flux at the 50 and 350 mm positions, this shall be done by adjusting the screws connecting the two frames. In this way, the pilot position with respect to the specimen will remain unchanged. Make no further change in the spacing of the two frames. The specimen stop screw adjustment shall be changed to meet the flux requirements in this test method, and then the position of the pilot burner mount shall be checked and, if necessary, adjusted to maintain the 10 + 2, - 0 mm pilot spacing.

NOTE A1.1—**Caution:** Water cooling of the fluxmeter is required to avoid damage to the fluxmeter and erroneous signals at low flux levels. The temperature of the cooling water shall be controlled in such a manner that the fluxmeter body temperature remains within a few degrees of room temperature. Correction of the flux measurement should be made for large temperature differences between the fluxmeter body and room temperature. Failure to supply water cooling may result in thermal damage to the sensing surface and loss of calibration of the fluxmeter.

A1.3.3 Once these operating conditions have been achieved, all future panel operation shall take place with the established air flow with gas supply as the variable to achieve the specimen flux as calibrated. Monitor this level with use of a radiation pyrometer fixed to view the source surface.

A1.3.4 Achieve the following adjustments and calibrations by burning methane gas from a line heat source located parallel to and in the same plane as the centerline of a dummy specimen located in the vertical position and without fluxmeters. This line burner consists of a 2-m length of pipe of 9.1-mm internal diameter. One end is closed off with a cap, and a line of 15 holes of 3-mm diameter is drilled at 16-mm spacing through the pipe wall. The gas is burned as it flows through this line of vertically positioned holes, and flames up through the stack. The measured flow rate and the net or lower heating value of the gas serve to produce a known heat release rate that is observed as a compensated thermocouple millivolt signal change. Prior to performing calibration tests, conduct measurements to verify that the stack thermocouple compensation has been properly adjusted.

A1.3.5 *Compensation Adjustment:*

A1.3.5.1 The fraction of the signal from the compensator thermocouple that is subtracted from the stack thermocouple is adjusted by means of the resistance of one leg of a potential divider shown in Fig. A1.3. The purpose of this adjustment is to eliminate, as far as practical, from the stack signal the long-term signal changes resulting from the relatively slow stack metal temperature variations. Fig. A1.4 shows the curves resulting from low compensation, correct compensation, and overcompensation. These curves were obtained by abruptly placing the lighted gas calibration burner adjacent to the hot end of a dummy specimen, and then extinguishing it. For this adjustment the calibration feed rate shall be set to correspond to a heat rate of 1 kW. The compensator potential divider shall be adjusted to yield curves that show a rapid rise to a steady state signal that is essentially constant over a 5-min period following the first minute of signal rise. The apparatus is

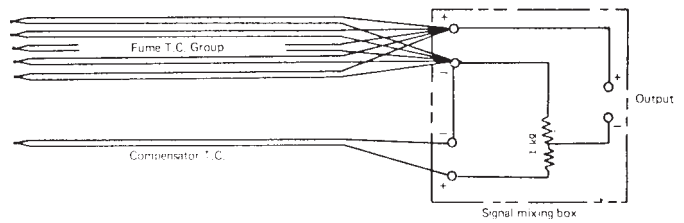

NOTE 1—Two sets of thermocouples and lead wires are required. The wire size and lengths within the fume thermocouple circuit group must be the same to ensure proper signal averaging. The parallel connection of the couples shall be achieved at the mixing box by plug connection of the leads. This allows quick removal and checks for continuity and grounding problems with minimum delay. No cold junction shall be used but the signal mixing box shall be shielded from panel radiation.

FIG. A1.3 Diagrammatic Sketch of Thermocouple Circuit

properly adjusted if, when the calibration burner is shut off, the signal rapidly decreases and reaches a steady state value within 2 min. Following this, there shall be no long-term rise or fall of the signal. Experience has shown that between 40 and 50 % of the compensation thermocouple signal is included in the output signal to achieve this condition, but variation in equipment will require other values. When properly adjusted, a square thermal pulse of 7 kW shall show not more than 7 % overshoot shortly after application of the calibration flame (see Fig. A1.5).

A1.3.6 *Fume Stack Calibration:*

A1.3.6.1 The following adjustments and calibrations shall be achieved by burning methane gas from a line heat source located parallel to and in the same plane as the centerline of a dummy specimen located in the vertical position and without fluxmeters. This line burner consists of a 2-m length of pipe of 9.1 mm internal diameter. One end is closed off with a cap; a line of 15 parallel holes of 3 mm diameter is drilled at 16 mm spacing through the pipe wall. The gas is burned as it flows through this line of vertically positioned holes, and flames up through the stack. The measured flow rate and the net or lower heating value of the gas serve to produce a known heat release rate which is observed as a compensated stack millivolt signal change. Prior to performing calibration tests, measurements shall be conducted to verify that the stack thermocouple compensation has been properly adjusted.

A1.3.6.2 With the dummy specimen mounted in position, the stack calibration shall be carried out with the panel producing a flux of 50.5 W/m² at the 50-mm location and the pilot burner not lit. Calibration of the stack millivolt signal rise above the initial steady state base following any initial overshoot peak shall be made by introducing and removing the line burner described in A1.3.4. The signal rise shall be that observed above the equilibrium base signal level with unlit calibration burner tube in position with ports at the hot end of the specimen. The flow rate of methane of at least 95 % purity shall be varied over the range of about 0.004 to 0.02 m³/min in sufficient increments to permit plotting the data in a well defined curve of stack compensated millivolt signal rise against the net or lower heat input rate. A similar calibration shall be performed with the calibration burner located at the cool end of the specimen. The results are acceptable if the two heat release rate curves show agreement within 15 %. A typical curve is

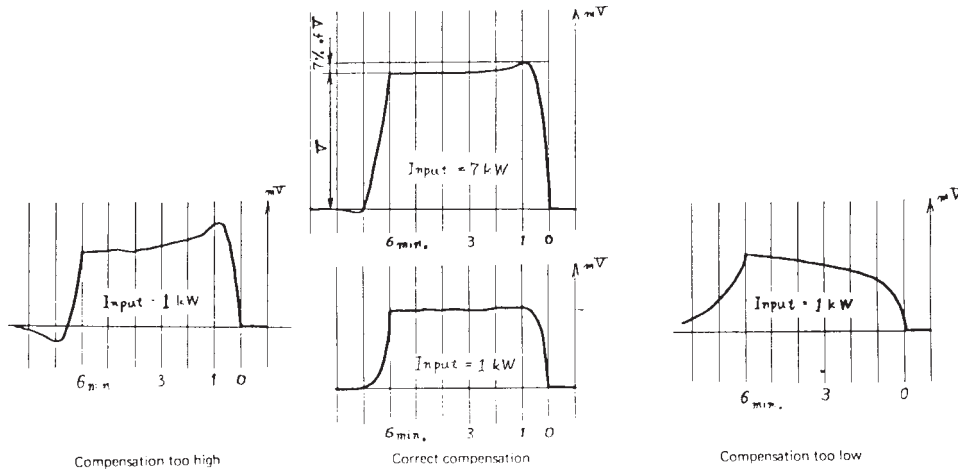

NOTE 1—The four curves shown illustrate changes in the indicated mV signal rise for three different levels of inverse feedback or compensation level.
FIG. A1.4 Response-Behavior of Heat Release Signal to a Square Wave Thermal Pulse

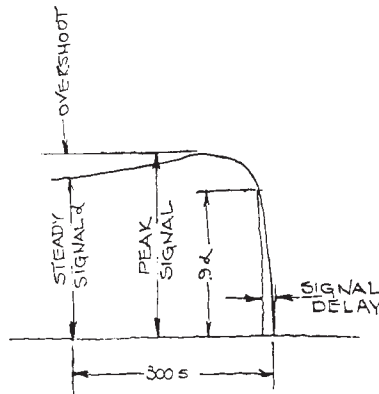

FIG. A1.5 Square Heat Transient Showing Overshoot and Signal Delay

shown in Fig. A1.6. The curve for the calibration burner at the hot end of the specimen shall be the one used for reporting all heat release measurements. This completes the calibration and the test equipment is ready for use.

A1.3.6.3 Once these operating conditions have been achieved, all future panel operation shall take place with the

established air flow with gas supply as the variable to achieve the specimen flux level as calibrated. Monitor this level with a fixed radiation pyrometer that points toward the source surface.

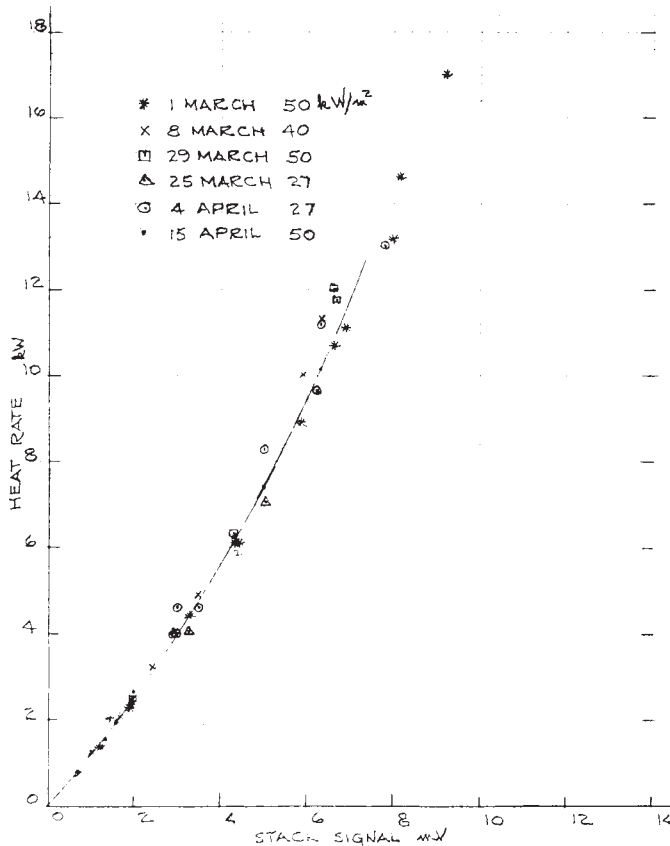

FIG. A1.6 Typical Stack Calibration Curve Including Data at Several Heat Rates

APPENDIX

(Nonmandatory Information)

X1. COMMENTARY ON FLAMMABILITY TEST

X1.1 Introduction

X1.1.1 The International Safety of Life at Sea (SOLAS) Convention (6) requires the use of marine finishes of limited flame spread characteristics in commercial vessel construction.

X1.1.2 The increased understanding of the behavior of unwanted fires has made it clear that flame spread alone does not adequately characterize fire behavior. It is also important to have other information, including ease of ignition, measured heat release, etc., during a fire exposure. Thus the International Maritime Organization (IMO) has adopted a test method essentially similar to the one described in this test method. Reference (1) describes the IMO procedure.

X1.1.3 Except for Test Method E 1321, which uses similar apparatus, this test method differs from many ASTM fire standards (Test Methods E 84, E 162, E 286, E 648, and E 970) since it does not attempt to provide a physical model of any fire system. Rather it provides for the measurement of a number of fire performance properties under a well defined severe radiant heat exposure. These fire properties may be combined by regulatory authorities to secure a measure of the fire risk

imposed by use of surface finish materials. Like all experimentally determined fire properties, the properties measured and defined by this test method are dependent on the test method and equipment described herein. Any reference to the properties should be accompanied by reference to this test method.

X1.2 History of the IMO Flammability Apparatus

X1.2.1 The test equipment covered by this test method was initially developed for IMO to meet the need for defining low flame spread requirements called for by the Safety of Life at Sea (SOLAS) Convention. The need was emphasized when in 1967 IMO, then IMCO, reached an agreement that noncombustible bulkhead construction would be required for all passenger vessels. These bulkheads were usually faced with decorative veneers.

X1.2.2 Some of the decorative veneers used on these bulkheads had proved highly flammable during fires. Various national flammability test methods were considered. Development of an International Standards Organization (ISO) test method was considered. Since it became apparent that development of a suitable test by ISO/TC92 would require more



time than IMO had envisioned, IMO decided during 1976–1977 to accept an offer from the United States delegation to develop a suitable prototype test. Initial work on the test method was jointly sponsored by the National Institute of Standards and Technology (NIST), then the National Bureau of Standards (NBS), and the United States Coast Guard.

X1.2.3 To facilitate ISO acceptance of this test method at a later date, specimens of the same size with similar mounting and exposure arrangements initially proposed by ISO were incorporated. However, there was in IMO a firm belief that a more severe thermal exposure would be required than that previously considered by ISO. It was also agreed that a measure of heat release was necessary for flammability measurement. Thus a new type of radiant heat source was developed with improved specimen-source configuration to permit reproducible specimen flux distribution control. Provision was made for a measure of heat release from the specimen mounted in the vertical plane. A noncontacting flame was included as a piloted ignition source.

X1.2.4 The objectives in developing this test method were as follows:

X1.2.4.1 To provide a test method for selection of materials of limited flammability, and

X1.2.4.2 To provide a test method capable of measuring a number of material fire properties in as specified a fashion as possible with a single specimen exposure.

X1.2.5 This test method differs from most fire test methods since it does not simulate a physical model of any fire system. Its use results in the measurement of a number of fire properties that must be considered together for flammability estimates.

X1.2.6 It was recognized that there may be several different ways in which these measurements could be utilized. It was suggested that IMO should use the test as a go/no go measuring tool for surface finish materials to limit the severity of their participation in a fire. The fire research community is interested in variable irradiance ignition measurements, coupled with flame spread measurements to derive more basic fire thermal properties of the materials studied. These objectives are defined in separate standards. This test method relates only to the test as used by IMO.

X1.3 Main Features of the Apparatus

X1.3.1 The test equipment has been developed to provide great flexibility for operating over a wide range of specimen thermal exposure. The specimens may be mounted either in a vertical or horizontal plane. In the vertical plane the flame front moves horizontally along the roughly 770 mm exposed length of the specimen. Since flames from the specimen rise at right angles to flame progress, radiant and convective heat transfer to unburned fuel ahead of the flame front is relatively low. Thus external heat flux incident on the unignited portion of the specimen at the flame front can be considered closely simulated by calibration measurements on a dummy specimen in the absence of combustion.

X1.3.2 With the specimen mounted in the horizontal plane, the situation is different. Convective flow over the specimen is less well organized. At the hot end the flame tends to flow in the direction of propagation, but later as the flame front progresses the flames rise more vertically. Both radiant heating

from the flame near the specimen as well as modification of panel radiance by smoke or flames, or both, on the panel surface may cause very significant deviation of irradiance over flux measured with the special calibration dummy specimen. For these reasons the main use of the equipment is expected to be confined to specimens tested in the vertical plane. It should also be noted that only in this plane can the specimen efflux be segregated from that of the radiant heat source and thus permit a measurement of heat release.

X1.3.3 Construction drawings with limited assembly details are available.⁵ The assembly drawings closely follow the prototype unit as modified to accept specimens of 75-mm thickness; however, the optional assembly method for 50-mm specimens originally used is preferred. The equipment is only recommended for use where methane or natural gas is available. Use of propane or other gases impose lower limits on panel radiance, requiring a change of the panel-specimen geometry to permit operation at 50.5 kW/m² (Note X1.1). Such modification will not permit operation at higher flux levels as is possible with natural gas. The drawings cover simple mixing of fuel gas and air just prior to entry to the panel plenum chamber. Some commercially produced units provide for electric spark ignition for the panel, as well as the safety feature of a venturi-type fuel gas-air mixer. In this arrangement, the low-pressure fuel gas is proportioned to follow the air flow controlled by a single valve. Any unit assembled should include adequate check valves to prevent reverse flow in the connected gas lines. Although not shown in detail on the drawings, electrical safety interlocks should be provided to shut the burner and pilot off in the event of a flashback resulting in combustion within the radiant-panel plenum, electrical-power failure, and failure of the air supply.

NOTE X1.1—Unless otherwise noted, the flux operating level of the equipment is that measured at the 50-mm position from the exposed hot end of the specimen. The flux at this location is 1 % higher than the average flux incident over the first 100 mm of the specimen length.

X1.4 Operating Range of the Equipment

X1.4.1 The apparatus has been developed to provide great flexibility for operation over a wide range of specimen exposure while mounted in either a vertical or horizontal plane. The vertical plane is preferred, since specimen thermal exposure is best defined with this specimen orientation. Operating characteristics described in X1.4.2 refer to specimens mounted in this manner.

X1.4.2 Ignition, Flame Spread, and Heat Release:

X1.4.2.1 Specimens 155 by 800 mm can be burned under a well defined flux gradient varying from 50.5 down to 1.5 kW/m² (about 3 % of maximum flux). This is the mode covered by this test method. With the described pilot flame the flux contributed by the pilot to the specimen is about 5 % of 50.5 kW/m².

X1.4.2.2 While the operating level required by this test method is from 50.5 kW/m², the unit can be operated with maximum specimen flux approaching 70 kW/m², or reduced to about 15 kW/m² with flux distribution closely proportional to that specified at 50.5 kW/m². However, at the lower maximum

flux range gaseous conduction and convection losses to the room ambient are likely to present deviations from strict proportionality.

X1.4.2.3 While this test method calls for tests with varying flux along the specimen length, specimens of 112 by 142 mm can be burned under an essentially uniform flux field at imposed flux levels between 15 and about 70 kW/m².

X1.4.2.4 Panel radiance can be monitored throughout the test for specimens in the vertical plane.

X1.4.2.5 The measurements made are dependent on use of a specific fluxmeter that has been accurately calibrated.

X1.4.2.6 As with almost all fire test methods, the measurements made are apparatus dependent and should only be reported with reference to the test method and procedure used.

X1.5 Test Data Reporting Method

X1.5.1 This test method has been developed to yield a number of fire properties in as well defined nature as possible. As such, the data resulting from use of this test must be combined and used together with other information to yield a measure of surface flammability. Although there may be numerous ways in which such an assessment can be achieved, the one currently being used by IMO involves, among other properties, the heat for ignition, and sustained burning. This heat comprises an average of the product of the time of flame arrival and the incident flux based on the calibration procedure used at the positions in question. It represents the heat per unit specimen area to which the portion of the specimen has been exposed prior to time of flame arrival. This differs from previous methods for a specific distance traveled. Heat for

sustained burning, while not a constant for a given specimen or material, is considered useful for characterizing flame spread behavior independently of the imposed heat-flux distribution involved. This statement is justified since experimental evidence indicates that flame arrival time at a specimen location primarily subjected to a given constant heat flux is controlled by the flux level involved.

X1.5.2 Fig. X1.1 shows flame spread plots of burning hardboard specimens under four quite different imposed flux distributions. Three of these were with the apparatus defined by this test method but operating at different peak flux levels of 50, 34, and 26 kW/m². The fourth dashed data curve was derived from apparatus using a flux distribution similar to that proposed by ISO with a 45° specimen heat-source configuration, but with a contacting pilot flame. These data coalesce very significantly as shown in Fig. X1.2 when flux at the flame front is plotted against flame arrival time. Of course the forced ignition with the contacting pilot flame of the ISO procedure shows a diverging starting transient due to early forced ignition. The poorer agreement of the data at flux levels below 10 kW/m² may have resulted from failure to recognize heat transfer from the room ambient to the fluxmeter during calibration of the ISO flux curve. Calculating heat for sustained burning as defined in this test results in an average value of 2.7 MJ/cm² with an associated coefficient of variation of 27 % for the six data items. The dotted line in Fig. X1.2 shows the extent to which this heat of continued burning value of 2.7 MJ/cm² fits into the group of data. From this example, it is quite evident that flame spread data becomes much more generally useful when plotted as flux at the flame front position against time of

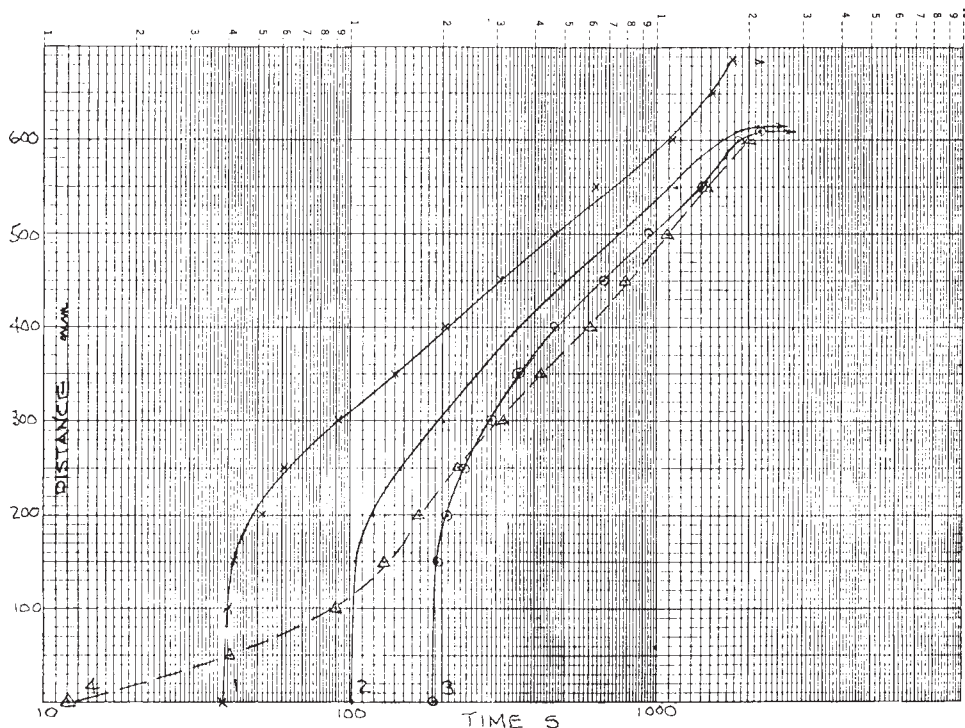

NOTE 1—The solid lines were determined using the IMO apparatus: curve No. 1 at 50 kW/m², No. 2 at 34 kW/m², and No. 3 at 26 kW/m². The dashed curve was determined using another apparatus with different flux distribution and an impinging pilot flame.

FIG. X1.1 Flame Spread Versus Time Data for Hardboard

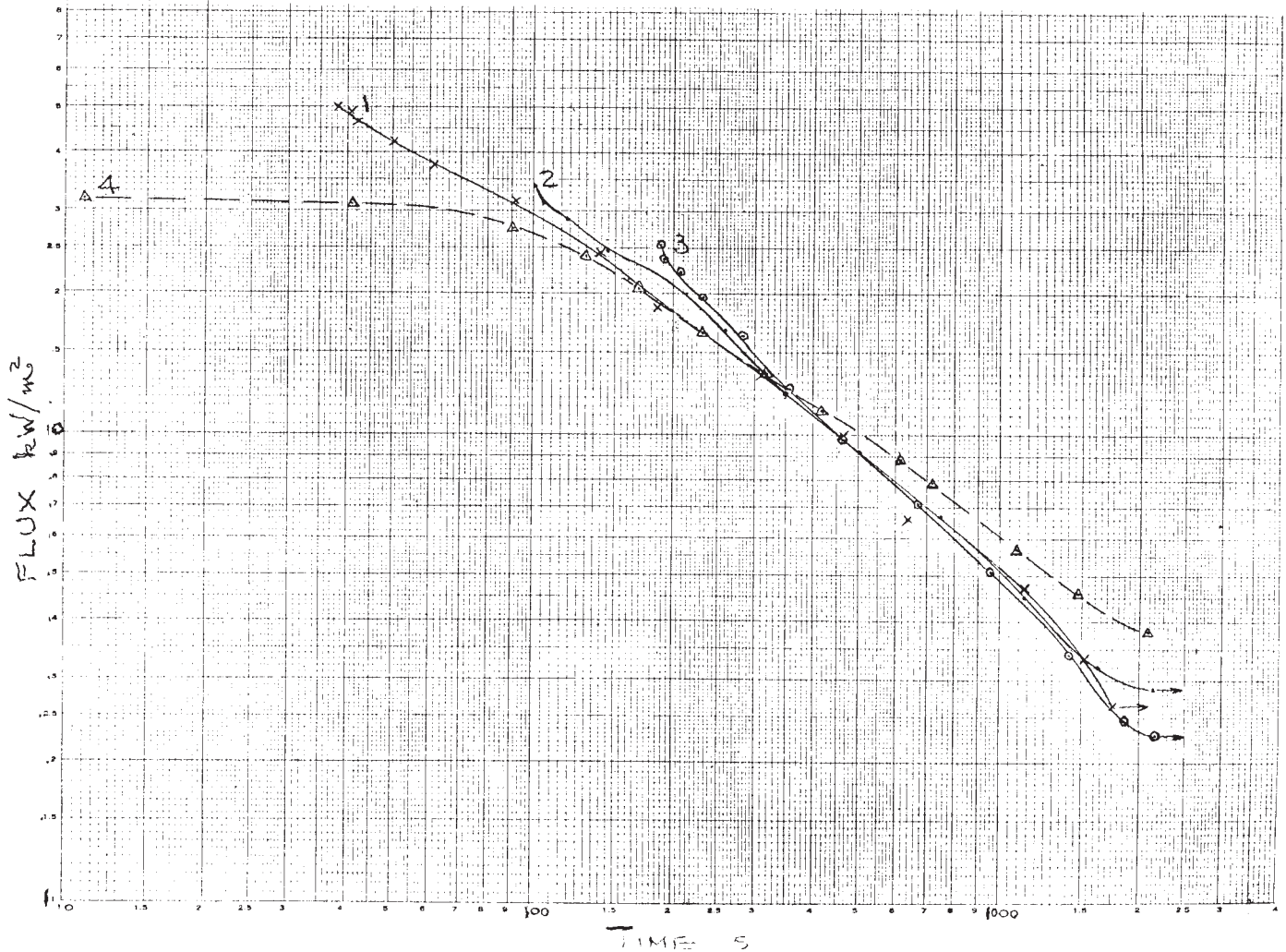

NOTE 1—The dotted line corresponds to the heat for sustained burning of 2.7 MJ/m² specified in 12.1.9.3.

FIG. X1.2 Data of Fig. X1.1 Plotted as Flux at Flame Front Versus Time

flame arrival. Fig. X1.3 presents data from a wide range of materials plotted in this way together with a scale of heat for sustained burning. In general, materials of higher heat of sustained burning and specially those also accompanied with high critical flux at extinguishment are significantly safer materials with respect to flame spread behavior than the others shown. Notice that, for the range of materials illustrated, the data appear to be grouped in three bands. From left to right these represent foamed polymerics, carpets, and low density cellulosics, and finally woods, gypsum board, and marine laminates. For a flammability assessment, heat release behavior also must be considered for an overall estimate of possible material behavior or acceptability.

X1.6 Some Problems with Flux Measurement

X1.6.1 The success of interlaboratory agreement of experimental data using this test method is dependent on the use of properly calibrated fluxmeters. At least two instruments should be available. One should be used as needed for calibration of the equipment and the other reserved as a reference standard. Instruments of the Schmidt-Boelter or thermopile type should

be used. They are preferable to the Gardon or foil type because of the former's more limited sensing surface temperature rise and thus greater sensitivity. This is rated as a 50 kW/m² unit since it yields roughly 10 mV at that incident flux. Since the manufacturer reports that these units can withstand operation at 500 % of their rating, they are unlikely to be damaged if used at flux levels of 70 kW/m².

X1.6.2 The reason for recommending fluxmeters of the thermopile type is to permit useful signals at the low flux end of the specimens while limiting temperature rise at high-flux levels of the sensing surface above that of the fluxmeter body as controlled by the cooling water.

X1.6.3 Fluxmeters of the type used may show two types of errors. Both are most prominent at flux levels below 10 kW/m². The first is an electrical bias signal as a result of radiation loss exchange between the fluxmeter and the room ambient that it views through a large solid angle at the low flux end of the specimen. This error can be largely reduced by maintaining the fluxmeter at room temperature or correcting the calibration signal by the bias measured with the fluxmeter viewing only the room enclosure. The second type of error is caused by the

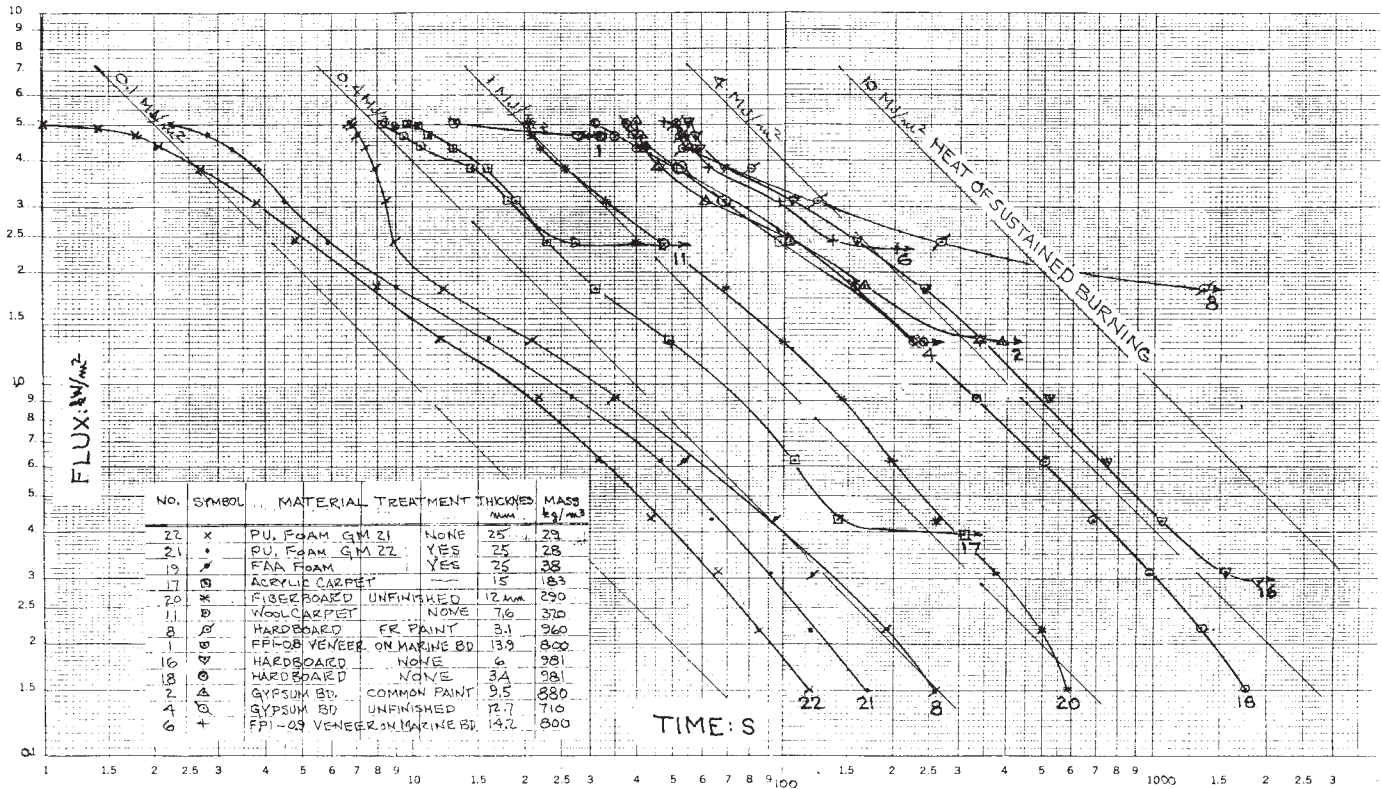

NOTE 1—A number of lines of constant heat of burning are included for reference.
FIG. X1.3 Data From a Wide Range of Materials Plotted as Flux at Flame Front Versus Time

heated convective film flowing up the specimen surface over the relatively cool fluxmeter surface. As with the bias error, this defect is most noticeable at the low flux end of the specimen. Measurements suggest that this error can be reduced by about 60 % by mounting the fluxmeter in such a way that the sensing surface projects 10 mm beyond the surface on which the film develops. This is accomplished by use of the special dummy specimen for flux gradient calibration.

X1.6.4 In some applications, fluxmeter measurement problems have been reported resulting from moisture condensation on the sensing surface. This type of problem should not exist with the IMO apparatus because the instruments are not exposed to combustion products during their use.

X1.7 Techniques Used for Flux Measurement

X1.7.1 An accurate measurement of flux incident on the specimen just ahead of the flame front would present a sizeable research activity impractical for use in routine testing. As a practical expedient, calibration of flux is carried out with use of a special dummy specimen shown in Fig. 1. This is made from marine board of 800 ± 100 kg/m³ density. The fluxmeter used should fit snugly in the various apertures. If the fit is loose or becomes loose, plastic tape around the fluxmeter may act as a shim.

X1.7.2 The first requirement in calibration is to adjust the panel and specimen positions to meet the requirements shown in Fig. A1.1. Dimension A is that perpendicular from the specimen to the exposed end of the refractory tile. The 15°

angle is between the specimen and tile surfaces. Dimension B is only approximate and should be adjusted by changing the spacing of the two frames so that the ratio of 50 to 350-mm flux is equal to 2.11. This corresponds to the required 50.5 kW/m² at 50 mm and a flux of 23.9 kW/m² at 350 mm. When this requirement has been achieved it is then a relatively simple matter to measure the flux at 15 of the defined locations shown in Table A1.1. This is accomplished by flux measurements at the apertures of the special calibration dummy specimen when fully inserted as well as after each of two 50-mm withdrawals of the specimen holder. During this calibration, the panel radiance must remain constant. Therefore, a radiation pyrometer or other suitable device should be used.

X1.7.3 The radiation pyrometer provides the working basis of establishing the desired specimen flux operating level. It does not need to be calibrated in terms of panel temperature, but will require calibration of its output signal in terms of the measured flux at the 50-mm position on the specimen. The latter is accomplished with a fluxmeter and the special calibration dummy specimen. For use in meeting the requirements of this test method, a determination of pyrometer signal for a fluxmeter measurement of 50.5 kW/m² is all that is required. However, since the equipment may also be used for ignition and heat release measurement at various flux levels, calibration may be desirable over the full operating range of the panel or radiant source. The resulting calibration curve will approximate a straight line, but may show a small deviation from that line.

X1.8 Uniform Flux Testing

X1.8.1 The specification of a flux operating level of 50.5 kW/m² is based on the fact that when operating at this level the average flux on the first 100 mm of the specimen is within about 1 % of longitudinal flux uniformity at 50 kW/m². Advantage can be taken of this fact for tests of ignition and heat release under uniform irradiance. Ignition tests have been reported by Harkleroad and Quintiere (7), while Ref (8) describes use of specimens with reduced surface dimensions for heat release measurements at uniform flux. In this latter application, use of a special sheet metal specimen retainer strip serves to complete the specimen support on the fourth side. In some cases the use of 25-mm mesh poultry netting is desirable with specimens that tend to soften, deform, or fragment during testing.

X1.9 Spread of Flame Measurements

X1.9.1 The construction drawings show details of the rakes and viewing mirror to assist in viewing the position of the flame front as it travels down the specimen. They do not describe a scale similar to that marked on the mirror face. This scale can be mounted on the underside of the horizontal specimen support member nearest the mirror. A scale in this position has been found to considerably simplify quick alignment of the rake at the specimen with the mirror marks. As the rakes are darkened following continued testing they may become difficult to identify. This may be corrected with a light spray application of white paint.

X1.9.2 Since specimen exposure flux is so uniform over the first 100 mm of specimen length, it may be difficult to measure flame arrival times on some specimens at 50 and 100-mm stations. Every effort should be made, however, to measure the ignition time corresponding to flame front at the midline of the specimen as well as at 150 mm and subsequent stations. During development of this test method, initial rapid flame spread was recorded with use of a strip chart recorder, as a chronograph, with paper speed of 5 mm/s. The chart drive was actuated by a switch closure as the specimen frame reached its full exposure condition. A hand-held momentary closure switch with dry cell and series resistance was used to insert event marks through the recording pen. This was used only for a period of 15 to 30 s following ignition. Later stages of flame progress were manually recorded by use of a digital second clock. Other types of chronographs that would serve the purpose equally well include a hand-held cassette recorder, a digital chronograph with printer, or a computer used to record the stack millivolt signal. However, if this is done, the chronograph signal should provide for time resolution to at least 0.1 signals.

X1.10 Heat Release

X1.10.1 This test method incorporates a fume stack or duct to permit securing a heat release-time curve during specimen burning under the thermal exposure conditions used. The measurement is made by use of five parallel connected bare thermocouples in the exhaust opening of the stack. The transient response of the signals from these junctions is improved by negative feedback from an electrically insulated

junction in good thermal contact with the stack wall. The magnitude of the feedback compensation signal used is controlled by a potential divider across the stack wall signal, see Fig. X1.4. The degree of compensation can be expressed as the ratio of r/R . This is the only adjustment available in the heat release measurement. This test method calls for selection of a compensation to yield a square heat pulse signal for a 1-kW signal while at the same time limiting initial transient overshoot to less than 7 % for a 7-kW square heat pulse (see Fig. A1.5).

X1.10.2 The heat pulse signals are produced by burning methane from a calibration line burner described in this test method. The burner is positioned with the axis of the burner ports vertical and with the burner tube axis in the same horizontal plane parallel to the centerline of the dummy specimen. The end of the calibration flame should be near the hot end of a dummy specimen exposed to the heat flux specified in this test method. The heat rates mentioned previously are defined by the lower heat of combustion of methane (802.3 kJ/gm mol) and the rate of methane flow. The popularity of variable orifice flow meters, that are usually calibrated for use with air, can result in serious errors unless corrections, appropriate for the particular meter used, have been made for methane. A properly calibrated dry test meter and stopwatch may be preferable.

X1.10.3 The stack calibration procedure described in A1.3.6.1 makes clear the requirement that stack calibration is to take place with the radiant panel operating, a dummy specimen in place, and the pilot burner unlit. The additional requirement that the calibration burner tube be in place in front and on the centerline of a dummy specimen has been found desirable because of a small change in stack signal base caused by increased convection heat flow. This becomes important when low level signals are being observed. The stack signal rise above the initial steady level for a range of gas feed rates in kW units defines the required calibration curve. In measuring the signal rise any initial overshoot should be neglected in preference to use of the final steady state level (see Fig. A1.5).

X1.10.4 Obviously, the mass of the fume stack and thus its heat capacity will have an effect on the transient response of the thermocouple system. Thus a close tolerance has been set on the metal thickness of the stack as 0.46 ± 0.05 -mm stainless steel.

X1.10.5 The transient resulting in a depression from the initial steady-state signal during start of a test complicates data reduction. Obviously, the base level above which the signal is

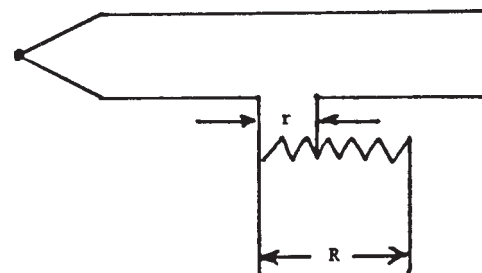

FIG. X1.4 Method of Measuring Stack Signal Compensation r/R From Ratio of Two Resistances

measured will vary perhaps in an exponential way during the test. While computer programs can be devised to compensate for change in the base signal level, it has seemed preferable to only require reporting of the heat release rate above the steady state level effective when the test was performed. Determination of this steady state does not require use of the calibration burner tube.

X1.10.6 Following equipment warm up with panel radiance set as observed with the radiation pyrometer, variations of the steady-state stack signal should not be large. Variations of more than a few tenths of a millivolt should be considered as a possible indication of trouble with the equipment. Checks for ground in the thermocouple system, open junctions, sooty junctions, etc., should be made. A check of flux to the specimen might also be in order. The method of data reduction will compensate for minor drift of steady-state base in a very significant way, since it allows for use of the calibration curve with zero either at the low point of the starting transient or a base level corresponding to extinction of the pilot burner. This assumes that heat release is calculated as the difference of the integrated release signal less the integrated area up to the test base signal level.

X1.11 Cautions in Equipment Calibration and Use for Heat Release Measurement

X1.11.1 While Table A1.1 only requires calibration of flux levels at eight positions along the specimen, it is important that either by interpolation or calibration at the fifteen positions shown a smooth curve be developed as the basis of determining the flux level at the positions of flame extinguishment.

X1.11.2 Any change in stack compensation adjustment will affect stack calibration. Thus this adjustment should be made first and then firmly fixed before calibration.

X1.11.3 Compensation may be done with a methane flow rate corresponding to a net or lower heat rate of 7 kW. At this rate compensation should be adjusted to show an over shoot above the final steady signal rise of 7 %. This behavior should result in an essentially square heat pulse when the methane feed rate is reduced to 1 or 2 kW.

X1.11.4 In use of the calibration burner, it should be set with the burner holes vertical. The burner tube should be set near the dummy specimen face and midwidth. Its position should be such that when looking along the burner tube the flames are seen to flow up into the stack without actual contact with the dummy specimen or the specimen holder metal parts.

X1.11.5 During calibration of the stack thermocouples the radiant panel should be operating to produce 50.5 kW/m² on the specimen at the 50 mm position. The pilot burner should not be lit. If the pilot burner is lit, the fuel feed ratio to the burner must be closely defined and used with any use of the resulting calibration.

X1.11.6 Fuel used for calibration should be methane of at least 95 % purity.

X1.11.7 Experience indicates that early tests with a new stack may show some small changes in calibration. For this reason it is best to run 6 or 8 tests with hardboard or similar material before a final calibration measurement is made.

X1.11.8 In performing the calibration the initial steady state signal should be that with the panel operating as mentioned above and with the calibration burner in position but with no gas flow. The final steady state millivolt *signal rise*, ignoring any initial transient peak, should be determined as a function of a range of gas feed rates.

X1.11.9 The data reduction method should recognize that the zero heat release level will be below the operating steady state level prior to test, by a millivolt change that corresponds to extinction of the pilot burner. Thus, heat release above the operating steady state can be calculated as the difference between that to the stack signal and that to the base level.

X1.11.10 Experience with this test method has shown that during warm-ups for a test the base-signal level can provide a sensitive warning of deviations from the desired operating conditions. These include (1) failure of the pilot burner, or its improper adjustment, and (2) changes in the stack thermocouple system such as shorts to ground, open circuits, heavy soot deposits, and improper connection after checking for shorts.

X1.11.11 In routine testing a strip chart record including measurements 3 min before, during, and after a test of both stack and radiation, pyrometer signals will be useful in showing the operating conditions under which the test was run.

X1.11.12 In reporting the degree of compensation used, it is only necessary to report the fraction of the compensator potential divider that is included in series with the stack signal. See Fig. X1.4.

X1.11.13 The compensation mixing box should be shielded from radiant and convective heat from the test equipment since no cold junction compensation is provided.



REFERENCES

- (1) "Recommendation on Improved Fire Test Procedures for Surface Flammability of Bulkhead, Ceiling and Deck Finish Materials," *Resolution A.653(16)*, International Maritime Organization, London, November 20, 1989.
- (2) Robertson, A. F., "Development of an Improved Radiant Heat Source for Fire Testing," *Fire and Materials*, Vol 6, No. 2, 1982, pp. 68–71.
- (3) "Fire Test Procedures: Report of First Interlaboratory Study of the IMO Flammability Test Method," *FP/342 (USA)*, International Maritime Organization, London, November 3, 1983.
- (4) "Results of Interlaboratory Study on Test Procedures for Surface Flammability of Bulkhead and Deck Finish Materials, Resolution A.564(14)," *FP33/INF.27*, International Maritime Organization, London, January 19, 1988.
- (5) "Analysis of Replies from the Questionnaire on the Second IMO Interlaboratory Study of IMO Resolution A5.64(14)," *FP33/INF.20*, International Maritime Organization, London, January 8, 1988.
- (6) *International Convention for the Safety of Life at Sea*, International Maritime Organization, London, 1986.
- (7) Quintero, J. G., and Harkelroad, M., "New Concepts for Measuring Flame Spread Properties," *Fire Safety Science and Engineering, ASTM STP 882*, ASTM, 1985, pp. 239–267.
- (8) "Heat Release Data Under Uniform Specimen Thermal Exposure Using the IMO Flammability Test," *FP/385 (USA)*, International Maritime Organization, London, March 27, 1985.

ASTM International takes no position respecting the validity of any patent rights asserted in connection with any item mentioned in this standard. Users of this standard are expressly advised that determination of the validity of any such patent rights, and the risk of infringement of such rights, are entirely their own responsibility.

This standard is subject to revision at any time by the responsible technical committee and must be reviewed every five years and if not revised, either reapproved or withdrawn. Your comments are invited either for revision of this standard or for additional standards and should be addressed to ASTM International Headquarters. Your comments will receive careful consideration at a meeting of the responsible technical committee, which you may attend. If you feel that your comments have not received a fair hearing you should make your views known to the ASTM Committee on Standards, at the address shown below.

This standard is copyrighted by ASTM International, 100 Barr Harbor Drive, PO Box C700, West Conshohocken, PA 19428-2959, United States. Individual reprints (single or multiple copies) of this standard may be obtained by contacting ASTM at the above address or at 610-832-9585 (phone), 610-832-9555 (fax), or service@astm.org (e-mail); or through the ASTM website (www.astm.org).