



Standard Test Method for Determining Material Ignition and Flame Spread Properties¹

This standard is issued under the fixed designation E 1321; the number immediately following the designation indicates the year of original adoption or, in the case of revision, the year of last revision. A number in parentheses indicates the year of last approval. A superscript epsilon (ϵ) indicates an editorial change since the last revision or reapproval.

1. Scope

1.1 This fire test response standard determines material properties related to piloted ignition of a vertically oriented sample under a constant and uniform heat flux and to lateral flame spread on a vertical surface due to an externally applied radiant-heat flux.

1.2 The results of this test method provide a minimum surface flux and temperature necessary for ignition ($\dot{q}''_{o,ig}$, T_{ig}) and for lateral spread ($\dot{q}''_{o,s}$, $T_{s,min}$), an effective material thermal inertia value ($k\rho c$), and a flame-heating parameter (Φ) pertinent to lateral flame spread.

1.3 The results of this test method are potentially useful to predict the time to ignition, t_{ig} , and the velocity, V , of lateral flame spread on a vertical surface under a specified external flux without forced lateral airflow. Use the equations in Appendix X1 that govern the ignition and flame-spread processes and which have been used to correlate the data.

1.4 This test method is potentially useful to obtain results of ignition and flame spread for materials. Data are reported in units for convenient use in current fire growth models.

1.5 SI units are used throughout the standard.

1.6 *This standard is used to measure and describe the response of materials, products, or assemblies to heat and flame under controlled conditions, but does not by itself incorporate all factors required for fire hazard or fire risk assessment of the materials, products, or assemblies under actual fire conditions.*

1.7 *This standard does not purport to address all of the safety concerns, if any, associated with its use. It is the responsibility of the user of this standard to establish appropriate safety and health practices and determine the applicability of regulatory limitations prior to use.* For specific hazard statements, see Section 7.

2. Referenced Documents

2.1 ASTM Standards:

E 84 Test Method for Surface Burning Characteristics of Building Materials²

E 162 Test Method for Surface Flammability of Materials Using a Radiant Heat Energy Source²

E 176 Terminology of Fire Standards²

E 286 Test Method for Surface Flammability of Building Materials Using an 8-ft (2.44-m) Tunnel Furnace³

E 648 Test Method for Critical Radiant Flux of Floor-Covering Systems Using a Radiant Heat Energy Source²

E 970 Test Method for Critical Radiant Flux of Exposed Attic Floor Insulation Using a Radiant Heat Energy Source²

E 1317 Test Method for Flammability of Marine Surface Finishes²

2.2 ASTM Adjuncts:ASTM

Detailed drawings (19), construction information, and parts list (Adjunct to E 1317)⁴

3. Terminology

3.1 *Definitions*—For definitions of terms used in this test method, refer to Terminology E 176.

3.2 Definitions of Terms Specific to This Standard:

3.2.1 *backing board, n*—a noncombustible insulating board, mounted behind the specimen during actual testing to satisfy the theoretical analysis assumption of no heat loss through the specimen. It shall be roughly 25 ± 5 mm thick with a density no greater than 200 ± 50 kg/m³.

3.2.2 *dummy specimen, n*—a noncombustible insulating board used for stabilizing the operating condition of the equipment, mounted in the apparatus in the position of the specimen and removed only when a test specimen is to be inserted. It shall be roughly 20 ± 5 mm in thickness with a density of 750 ± 100 kg/m³.

3.2.2.1 *Discussion*—For the ignition tests, the dummy specimen board shall have a hole at the 50-mm position for mounting the fluxmeter.

3.2.3 *effective thermal property, n*—thermal properties derived from heat-conduction theory applied to ignition/ flame-spread data treating the material as homogenous in structure.

3.2.4 *mirror assembly, n*—a mirror, marked and aligned with the viewing rakes, used as an aid for quickly identifying and tracking the flame-front progress.

¹ This test method is under the jurisdiction of ASTM Committee E-5 on Fire Standards and is the direct responsibility of Subcommittee E05.22 on Surface Burning.

Current edition approved June 10, 1997. Published August 1997. Originally published as E 1321 – 90. Last previous edition E 1321 – 97.

² *Annual Book of ASTM Standards*, Vol 04.07.

³ Discontinued; see *1992 Annual Book of ASTM Standards*, Vol 04.07.

⁴ Available from ASTM Headquarters. Order ADJE1317.

3.2.5 *special calibration board, n*—a specially assembled noncombustible insulating board used for standardizing the operating condition of the equipment which is used only to measure the flux distribution at specified intervals along the specimen surface. It shall be roughly 20 ± 5 mm in thickness with a density of 750 ± 100 kg/m³.

3.2.6 *thermally thick, n*—the thickness of a medium that is large enough to have the predominate thermal (temperature) effects experienced within that distance, that is, negligible heat is lost from its unexposed side.

3.2.7 *thermal operating level, n*—the operating condition at which the radiance of the heat source produces a specified constant heat flux to some specified position at the specimen surface.

3.2.8 *viewing rakes, n*—a set of bars with wires spaced at 50-mm intervals for the purpose of increasing the precision of timing flame-front progress along the specimen.

3.3 Symbols: Symbols:

- b = ignition correlation parameter, s^{-1/2}.
- C = flame heat transfer factor, m^{s/2}/kW·s^{1/2}.
- CF = ratio of radiation pyrometer signal to flux incident on dummy specimen as measured during calibration; a linear correlation is assumed, mV/(kW/m²).
- $F(t)$ = specimen thermal response function.
- $F(x)$ = surface flux configuration invariant, (kW/m²)/mV.
- h = heat loss coefficient, kW/m²·K.
- \dot{q}''_e = measured incident flux, kW/m².
- $\dot{q}''_{o,ig}$ = critical flux for ignition, kW/m².
- $\dot{q}''_{o,s}$ = critical flux for spread, kW/m².
- t = time, s.
- t^* = characteristic equilibrium time, s.
- t_1 = time at sample insertion, s.
- t_2 = time at ignition, s.
- t_{ig} = ignition time under incident flux, s.
- T_{ig} = ignition temperature, °C.
- $T_{s,min}$ = minimum temperature for spread, °C.
- T_∞ = ambient and initial temperature, °C.
- V = flame (pyrolysis front) velocity, m/s.
- x = longitudinal position along centerline of specimen, m.
- Φ = flame heating parameter, (kW)²/m³.
- k_{pc} = thermal heating property, (kW/m²·K)² s.
- ϵ = surface emissivity.
- σ = Stefan-Boltzmann constant, kW/m²·K⁴.

4. Summary of Test Method

4.1 This test method consists of two procedures; one to measure ignition and one to measure lateral-flame spread. Vertically mounted specimens are exposed to the heat from a vertical air-gas fueled radiant-heat energy source inclined at 15° to the specimen (see Fig. 1).

4.1.1 For the ignition test, a series of 155, +0, -5 mm by 155, +0, -5 mm specimens (see Fig. 1) are exposed to a nearly uniform heat flux (see Fig. 2) and the time to flame attachment, using piloted ignition (see Fig. 3), is determined.

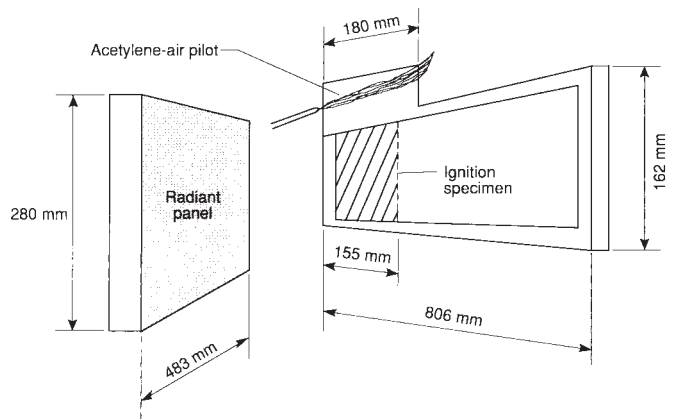

FIG. 1 Schematic of Apparatus With Ignition Specimen

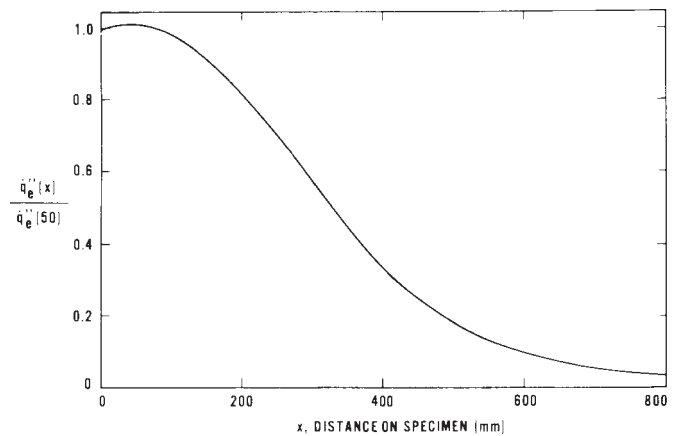
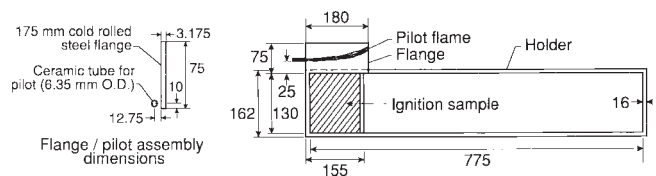

FIG. 2 Normalized Flux Over Specimen



NOTE 1—All dimensions are in millimetres.
FIG. 3 Pilot Configuration for Ignition Test

4.1.2 For the flame spread test, a 155, +0, -5 mm by 800, +0, -5 mm specimen (see Fig. 1) is exposed to a graduated heat flux (see Fig. 2) that is approximately 5 kW/m² higher at the hot end than the minimum heat flux necessary for ignition; this flux being determined from the ignition test (see 11.2). The specimen is preheated to thermal equilibrium; the preheat time being derived from the ignition test (see 12.1). After using piloted ignition, the pyrolyzing flame-front progression along the horizontal length of the specimen as a function of time is tracked. The data are correlated with a theory of ignition and flame spread for the derivation of material flammability properties.

5. Significance and Use

5.1 This test method addresses the fundamental aspects of piloted ignition and flame spread. The procedure is suitable for the derivation of relevant material flammability parameters that



FIG. 4 General View of Apparatus

include minimum exposure levels for ignition, thermal-inertia values, and flame-spread properties.

5.2 This test method is used to measure some material-flammability properties that are scientifically constant and compatible and to derive specific properties that allow the prediction and explanation of the flame-spread characteristics of materials. They are considered effective properties that are dependent on the correlations used and when combined with theory can be used over a wide range of fire conditions for predicting material ignition and flame-spread behavior.

5.3 Do not use this test method for products that do not have planar, or nearly planar, external surfaces and those products and assemblies in which physical performance such as joint separation and fastening methods has a significant influence on flame propagation in actual fire conditions.

5.4 In this procedure, the specimens are subjected to one or more specific sets of laboratory test conditions. If different test conditions are substituted or the end-use conditions are changed, it is not always possible by or from this test method to predict changes in the fire-test-response characteristics measured. Therefore, the results are valid only for the fire test exposure conditions described in this procedure (see also 1.6).

6. Apparatus

6.1 *Test-Equipment Fabrication*—Fig. 4 shows a photograph of the equipment as assembled ready for test. Figs. 5 and 6 show schematics of the apparatus.⁴ These provide engineering information necessary for the fabrication of the main frame, specimen holders, stack, and other necessary parts of

the equipment. Some commercially available units have added safety features that are not described in the drawings.

NOTE 1—The specimen fume stack available in some commercial models is not required for this test procedure.

6.2 A brief parts list for the test-equipment assembly includes:

6.2.1 *Main Frame* (see Fig. 5), consisting of two separate sections, the radiant-panel support frame and the specimen support frame. The two frame sections shall be joined in a manner that allows adjustments in the relative position of the radiant panel to the specimen to be made easily.

6.2.2 *Specimen Holders*, to provide for support of the specimen during test; at least two of these are required, and three prevent delays resulting from required cooling of holders prior to mounting specimens.

6.2.3 *Radiant Panel*, consisting of a radiation surface of porous refractory tiles mounted at the front of a stainless steel plenum chamber to provide a flat radiating surface of approximately 280 by 483 mm. The plenum chamber shall include baffle plates and diffusers to distribute the gas/air mixture evenly over the radiation surface. The gas/air mixture enters the plenum chamber at one of the short sides to facilitate easy connection when the panel is mounted from the frame. A reverberatory screen (see Fig. 6) is provided immediately in front of the radiating surface to enhance the combustion efficiency and increase the radiant output.

6.2.4 *Air and Fuel Supply*, to support combustion of the radiant panel. The appropriate air and fuel flow-metering

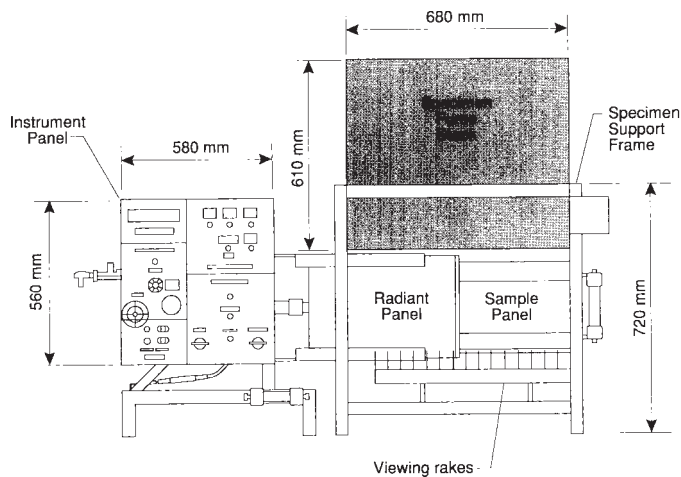

FIG. 5 Test Apparatus Main Frame, Front View

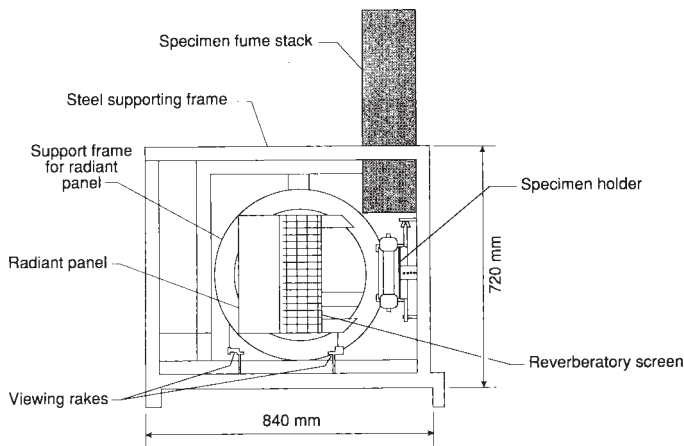

FIG. 6 Test Apparatus, Side View

devices, gas control valves, pressure reducer, and safety controls are all mounted on the panel support frame (see Fig. 5). Requirements are as follows:

6.2.4.1 A regulated air supply of about $8.33 \times 10^{-3} \text{ m}^3/\text{s}$ at a pressure sufficient to overcome the friction loss through the line, metering device, and radiant panel; the radiant-panel pressure drop amounts to approximately 20 to 30 Pa. A flowmeter suitable for indicating air flow over the range of 2 to $15 \times 10^{-3} \text{ m}^3/\text{s}$ shall be provided. A flowmeter suitable for indicating methane flow rates over the range of 0.1 to $1.1 \times 10^{-3} \text{ m}^3/\text{s}$ shall be provided.

6.2.4.2 The fuel gas used shall be either natural gas or methane. A pressure regulator shall be provided to maintain a constant supply pressure. Gas is controlled by either a manually adjusted needle valve or a venturi mixer. The venturi mixer will allow one to control the flux level of the panel by adjusting only the air valve. The fuel gas-flow requirements are roughly 0.26 to $1.03 \times 10^{-3} \text{ m}^3/\text{s}$ at a pressure sufficient to overcome line pressure losses.

NOTE 2—If a venturi mixer is used, the regulated air and fuel gas supply shall be sufficient for efficient operation of the venturi mixer.

6.2.5 *The Specimen Holder Support Frame Guides, Pilot Flame Holder, Fume Stack (optional), Flame Front Viewing*

Rakes, Radiation Pyrometer, and Mirror are all assembled on the specimen support frame. The arrangement of parts on this frame is shown in Figs. 4-6.

6.2.6 *Dummy Specimen*, of noncombustible insulating board of the thickness and density specified in the test procedure, shall be mounted on the apparatus in the position of the specimen except during actual testing or calibration.

6.3 Instrumentation:

6.3.1 *Total Radiation Pyrometer*, compensated for its temperature variation and having a nominal sensitivity between the thermal wavelengths of 1 and $9 \mu\text{m}$ that shall view a centrally located area on the radiant panel of about 150 by 300 mm. The instrument shall be securely mounted on the specimen support frame in such a manner that it can view the radiant panel surface oriented for specimens in the vertical position.

6.3.2 *Heat Fluxmeters*—Have available at least three fluxmeters for this test method. One of these shall be retained as a laboratory reference standard. The fluxmeters shall be of the thermopile type with a nominal range of 0 to $50 \text{ kW}/\text{m}^2$ and have a sensitivity of approximately 10 mV at $50 \text{ kW}/\text{m}^2$. They shall have been calibrated to an accuracy of 5 % over this range. The time constant of these instruments shall not be more than 290 ms (corresponding to a time to reach 95 % of final output of not more than 1 s). The target sensing the applied flux shall occupy an area not more than 4 by 4 mm and be located flush with and at the center of the water-cooled 25-mm circular exposed metallic end of the fluxmeter. If fluxmeters of smaller diameters are to be used, these shall be inserted into a copper sleeve of 25-mm outside diameter in such a way that good thermal contact is maintained between the sleeve and water-cooled fluxmeter body. The end of the sleeve and exposed surface of the fluxmeter shall lie in the same plane. Radiation shall not pass through any window before reaching the target.

6.3.3 *Timing Devices*, such as a chronograph, a digital clock, a stopwatch, a tape recorder, a data acquisition/computer system, or video camera shall be used to measure the times of ignition and flame-front advancement.

6.3.4 *Digital Millivoltmeter or Data Acquisition System*, capable of indicating signal changes of $10 \mu\text{V}$ or less, is suitable for monitoring changes in operating conditions of the radiant panel.

6.4 Space for Conducting Tests:

6.4.1 *Test Area*, at least 45-m^3 volume with a ceiling height of not less than 2.5 m. The floor area supporting the apparatus shall be level.

6.4.1.1 The apparatus shall be located with a clearance of at least 1-m separation between it and the walls of the test room. No combustible finish material of ceiling, floor, or walls shall be located within 2 m of the radiant heat source.

6.4.2 *Fume Exhaust System*—An exhaust system shall be installed with a capacity for moving air and combustion products at a rate of $0.3 \text{ m}^3/\text{s} \pm 5\%$. The exhaust system should be surrounded by a 1.3 by 1.3-m refractory fiber skirt hanging down to $1.7 \pm 0.1 \text{ m}$ from the floor of the room. The specimen support frame and radiant panel should be located beneath this hood in such a way that all combustion fumes are withdrawn from the room.

6.4.3 *Air Supply*—Access to an exterior supply of air, to replace that removed by the exhaust system, is required. This shall be arranged in such a way that the ambient room temperature remains at $25 \pm 5^\circ\text{C}$.

6.4.4 *Room Drafts*—Measurements shall be made of air speeds near a dummy specimen in the vertical position while the fume exhaust system is operating but the radiant panel and its air supply are turned off. At a distance of 100 mm from the panel, perpendicular to the lower edge and at midlength of the panel, the air flow shall not exceed 0.2 m/s in any direction.

7. Hazards

7.1 Safeguards shall be installed in the panel fuel supply system to guard against a gas air fuel explosion in the test chamber. The safeguards shall include, but are not limited to, one or more of the following: a gas feed cut-off activated when the air supply fails; a flame sensor directed at the panel surface that stops fuel flow when the panel flame goes out; and a heat detector mounted in contact with the radiant panel plenum that is activated when the panel temperature exceeds safe limits. Manual reset is a requirement of any safeguard system used.

7.2 The exhaust system must be so designed and operated that the laboratory environment is protected from smoke and gas. The operator shall be instructed on ways to minimize exposure to combustion products by following sound safety and industrial hygiene practices. For example, ensure that the exhaust system is working properly and wear appropriate clothing including gloves, safety glasses, breathing apparatus (when hazardous fumes are expected), etc.

7.3 During this test, very high irradiances are generated that are capable of igniting some clothing following even brief exposures. Take precautions to avoid ignitions of this type.

8. Test Specimens

8.1 The specimens selected for testing shall be representative of the product as it is intended for use.

8.2 *Specimen Thickness*—The requisite specimen shall be thermally thick. Materials and composites of normal thickness 50 mm or less shall be tested using their full thickness.

NOTE 3—Some commercially available units may be used for testing specimens with thickness of $75, +0, -3$ mm.

8.2.1 *Composites*—Assemblies shall be as specified in 8.2. However, where thin materials or composites are used in the fabrication of an assembly, it is possible that the presence of an air gap, or the nature of any underlying construction, or both, significantly affects the flammability characteristics of the exposed surface. Use the same substrate for testing as used during field installation. If that substrate cannot be used or if it is unknown, a reference substrate must be used in its place. The standard reference substrate is fiber-reinforced cement board with a nominal thickness of 6.3 mm, a density of 1762 ± 80 kg/m³, and uncoated. When testing a thin material or a composite assembly, ensure that no air gap exists between the specimen and the substrate material.

8.2.2 Specimens shall be tested in the form of intended use.

8.3 *Specimen Size*:

8.3.1 *Ignition Test*—The specimens shall be $155, +0, -5$ by $155, +0, -5$ mm and shall be representative of the product.

8.3.2 *Flame Spread Test*—The specimens shall be $155, +0, -5$ by $800, +0, -5$ mm and shall be representative of the product.

8.4 *Number of Specimens*:

8.4.1 *Ignition Test*—Obtaining the ignition-flux profile requires the testing of six to twelve specimens.

8.4.2 *Flame Spread Test*—Test three specimens for each different exposed surface of the product tested.

9. Calibration of Apparatus

9.1 Perform mechanical, electrical, and thermal calibrations as described in Annex A1. Perform these adjustments and calibrations following initial installation of the apparatus and at other times as the need arises.

9.2 *Monthly Verification*—In a continuous program of tests, the flux distribution shall be determined not less than once a month. Where the time interval between tests is greater than one month, the flux distribution shall be determined at the start of the test series.

9.3 *Continuous Monitoring of Operation*—A dummy specimen shall remain mounted in the position normally occupied by a specimen whenever the equipment is in stand-by operation. This is a necessary condition of the continuous monitoring procedure that is accomplished by measuring the following:

9.3.1 The millivolt signal from a heat fluxmeter positioned 50 mm from the exposed end of a dummy specimen, and

9.3.2 The millivolt signal from the radiation pyrometer mounted securely on the specimen holder frame facing the surface of the radiant panel.

9.3.3 Either of these measurement methods is satisfactory for determining that the required thermal operating level has been achieved. Satisfactory results require that both signals show no drift for 3 min prior to test. The observed operating level of the panel from either the radiation pyrometer or the fluxmeter shall correspond, within 2 %, to the similarly measured conditions during the calibration procedure mentioned in A1.3.

10. Conditioning

10.1 *Specimen Conditioning*—Before testing, condition the specimens to constant moisture content at a temperature of $23 \pm 3^\circ\text{C}$ and a relative humidity of 50 ± 5 %. Constant moisture content is considered to be reached when, following two successive weighings, carried out at 24-h intervals, the measured mass does not differ by more than 0.1 % of the mass of the specimen.

10.2 *Specimen Preparation*—Prior to insertion in the specimen holder, wrap the back and edges of the specimen in a single sheet of 0.2 mm thick aluminum foil. When inserted in the specimen holder, back each specimen with a 25-mm sheet of noncombustible refractory insulating material of the same lateral dimensions, density, and thermal characteristics as the backing board.

10.2.1 *Flame Spread Test*—Using an appropriate marker such as chalk, or a soft pencil, draw a line along the center horizontal length of the exposed face of each specimen. Make vertical markings at 25-mm (or less) increments as an aid in tracking the flame-front progress.

11. Procedures

11.1 *General*—This test method involves mounting conditioned specimens in a well defined flux field and measuring ignition times, spread of flame, and position of final extinguishment. Therefore, these procedures assume that the apparatus has been prepared and calibrated as described in Section 10 and Annex A1.

- 11.1.1 Start the fume exhaust system.
- 11.1.2 Slide the dummy specimen into the apparatus.
- 11.1.3 Turn on the regulated air supply to the radiant panel.
- 11.1.4 Position ignitor approximately 2 cm in front of the radiant-panel surface.
- 11.1.5 Turn on the gas supply to ignite the radiant panel.

11.1.6 Adjust the air/gas flow for the appropriate thermal operating level by referencing the millivolt signal from the water cooled heat fluxmeter that monitors the irradiance at the 50-mm position on the dummy specimen or the millivolt signal from the total-radiation pyrometer that monitors the radiant-panel surface, or both. Make the adjustments to the output of the radiant panel by first adjusting the air supply and then, if necessary, adjusting the gas supply. Allow at least 15 min for the radiant panel to reach equilibrium.

11.1.7 If the heat fluxmeter signal is used in establishing the appropriate operating level, turn on the cooling water to the fluxmeter prior to positioning the fluxmeter in the special 50-mm dummy specimen. The cooling water shall be within $\pm 3^{\circ}\text{C}$ of room temperature. Use the dummy specimen fabricated to accommodate the fluxmeter at the 50-mm position.

11.2 *Ignition Test Procedure:*

11.2.1 Adjust the thermal operating level for an external flux $\{ \dot{q}''_e(x) \}$ of 30 kW/m^2 to the specimen surface at the 50-mm position.

11.2.2 Ignite the pilot; adjust the air/acetylene control valves so that a light-blue conical flame extends approximately 180 mm lengthwise across the contiguous wall flange at the top of the specimen holder (see Fig. 3).

11.2.3 Check and, if necessary, readjust the apparatus to the appropriate thermal operating level. Allow the apparatus to stabilize for at least 3 min.

11.2.4 Record the output of the radiation pyrometer for the purpose of monitoring the radiant panel operating level during testing. A sample data-log format is shown in Fig. 7.

11.2.5 Record the external flux $\{ \dot{q}''_e(x) \}$ as determined from the output of the fluxmeter at the 50-mm position.

11.2.6 Record the ambient room temperature, T_{∞} .

11.2.7 Remove the fluxmeter from the dummy specimen.

11.2.8 Within a 10-s interval, remove the holder containing the dummy specimen from the apparatus and insert the holder containing the test specimen. Using a suitable instrument such as a stopwatch, audiovisual instrument, data acquisition/computer system, chronograph, or strip chart recorder, or any combination thereof, record the time (t_1) when the test specimen is fully in place and the time (t_2) of flame attachment to the specimen surface. Time of ignition (t_{ig}) is defined as the time after specimen insertion to the time of flame attachment to the specimen surface ($t_2 - t_1$). Terminate the test at 20 min if ignition does not occur.

11.2.9 Record the time to ignition, t_{ig} .

IGNITION DATA LOG

Date: _____ Test Number: _____ Time: _____

Orientation: _____

Pilot Configuration: _____

Specimen: _____

Size: _____ mm Humidity: _____ RH %

Specimen Backing: _____ Density: _____ kg/m^2

Comment: _____

Flux Sensor No: _____ Calibration Factor: _____

Flux Sensor Reading: _____ mV _____ kW/m^2 (\dot{q}''_e)

Pyrometer Reading: _____ mV _____ kW/m^2 (\dot{q}''_e)

Comments: _____

Time to:

Ignition of upper flame _____ s

Oscillating flames _____ s

Attached flame (t_{ig}) _____ s

Comments: _____

FIG. 7 Data Logging Format Sample, Ignition Test

11.2.10 If ignition occurred, readjust the external flux $\{ \dot{q}''_e(x) \}$ at the 50-mm position downward using increments of approximately 5 kW/m^2 and repeat the test until a flux at which no ignition occurs has been identified. If ignition did not occur, readjust the external flux $\{ \dot{q}''_e(x) \}$ at the 50-mm position upward (using increments of approximately 5 kW/m^2), and repeat the test (using fresh specimen(s)) until a minimum flux at which ignition occurs has been identified.

11.2.11 Determine a minimum flux for ignition ($\dot{q}''_{o,ig}$) by bracketing within $\pm 2 \text{ kW/m}^2$ the fluxes for ignition/no ignition.

11.2.12 Repeat 11.2.1-11.2.9 adjusting the external flux $\{ \dot{q}''_e(x) \}$ at the 50-mm position upward (using increments of approximately 10 kW/m^2), until an ignition time flux profile (Fig. 8) has been determined for fluxes $\{ \dot{q}''_e(50) \}$ between the minimum flux for ignition ($\dot{q}''_{o,ig}$) and 65 kW/m^2 . Depending on the number of tests required to bracket the minimum flux for ignition, this may require eight to twelve tests.

11.3 *Flame Spread Test Procedure:*

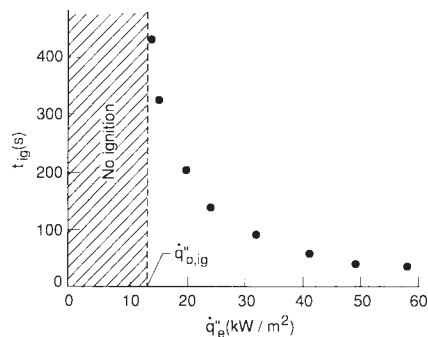

FIG. 8 Ignition Time as a Function of External Irradiance

11.3.1 Remove the pilot flame so that it does not come in contact with the fuel gases emitted from the heated specimen.

11.3.2 With the dummy specimen in place, adjust the thermal operating level to the specimen surface, 50 mm from the hot end, for an irradiance that is at roughly 5 kW/m² higher than the minimum irradiance ($\dot{q}''_{o,ig}$) necessary for ignition. Allow the apparatus to stabilize for 3 min.

NOTE 4—This flux should be selected for ease in tracking the flame front. For most materials this will be between 5 and 10 kW/m² above the minimum ignition flux.

11.3.3 Record the external flux { $\dot{q}''_e(x)$ } to the specimen surface at the 50-mm position. If applicable for data recording, start the data acquisition/computer system, the audiovisual instrument, or the strip chart recorder, or combination thereof.

11.3.4 Within a 10-s interval, remove the holder containing the dummy specimen from the apparatus and insert the holder containing the test specimen. Immediately activate the timing mechanism.

11.3.5 Record the time when the test specimen is fully in place by using the audio portion of the audiovisual instrument, observing the stopwatch, or activating the event marker connected to the computer, strip-chart recorder, or chronograph. A sample flame spread data log format is shown in Fig. 9.

11.3.6 Allow the specimen to preheat for the time, t^* (from correlated ignition-test data) and replace the pilot flame to the position shown in Fig. 3. If the specimen does not ignite, a repeat test (fresh specimen) using a modified ignition source should be conducted, that is, follow steps 11.3.1-11.3.5, allow the specimen to preheat for the time, t^* , and ignite the specimen by manually moving a pilot along the bottom surface of the specimen in the direction of decreasing irradiance.

11.3.7 Record the time of ignition (t_{ig}).

11.3.8 Visually track the flame-front progress along the longitudinal centerline of the specimen by using the mirror assembly, the viewing rakes, or the markings on the specimens, or combination thereof. Record the arrival time of the flame front at 25-mm increments. As an alternate to the use of the mirror assembly for materials that propagate flame spread rapidly following ignition, audiovisual equipment shall be used to record the arrival time of the flame front at the incremented positions.

11.3.9 Terminate the test if flaming reaches the end of the specimen or self-extinguishes and thus ceases progress along the specimen.

11.3.10 Record both the time, t , (in seconds) and the position, x , (in millimetres) along the specimen at which the flame-front progression ceases.

11.3.11 *Observations*—In addition to recording experimental data, document observations on general behavior of the specimen including glowing, charring, melting, flaming drips, disintegration of the specimen, etc.

11.3.12 Repeat operations 11.3.1-11.3.11 for two additional specimens.

12. Calculation

12.1 Ignition Test Calculation:

12.1.1 The theories used to develop correlation of ignition test data are developed in Appendix X1 and Appendix X2.

12.1.2 Plot test-data results ($\dot{q}''_{o,ig}/(\dot{q}''_e)$) versus \sqrt{t} (see Fig. X1.2 (a) and (b)).

12.1.3 Fit straight line to data (solid line, see Fig. X1.2 (a) and (b)). See Appendix X1 for the rationale for using this technique.

12.1.4 Determine ignition parameters, b and t^* , from the respective slope of the line drawn through the data and the intercept of this line with the line $F(t) = 1 = \dot{q}''_{o,ig}/\dot{q}''_e$ (see Fig. X1.2 (a)).

12.1.5 Using the minimum flux required for ignition ($\dot{q}''_{o,ig}$) (see 11.2.11), determine the surface ignition temperature (T_{ig}) (see Fig. 10 and Eq X1.9).

NOTE 5—Assuming a surface emissivity of one and steady conditions, h depends only on the apparatus configuration (geometry) and operating level. Here steady-state surface temperatures were measured for a number of real building materials over a range of heat-flux levels and also calculated for $h_c = 15 \text{ W/m}^2\cdot\text{k}$. Fig. 10 shows the theoretical and measured data linking specimen-surface temperature to imposed heat flux. This curve can be used with reasonable accuracy to infer surface temperature at ignition (T_{ig}) for the $\dot{q}''_{o,ig}$ as a substitute to Eq X1.9 in Appendix X1.

12.1.6 Determine effective thermal property ($k\rho c$) as follows (see also Eq X1.12 in Appendix X1):

$$k\rho c = \frac{4}{\pi} \left(\frac{h}{b} \right)^2 \quad (1)$$

where h = the heat-transfer coefficient at ignition, determined as follows (see also Eq X1.7 in Appendix X1):

$$h = \frac{\dot{q}''_{o,ig}}{T_{ig} - T_\infty} \quad (2)$$

12.2 Flame Spread Test Calculation:

12.2.1 The theory used to develop the correlation of flame-spread test data are developed in Appendix X1 and Appendix X2.

12.2.2 Using the flux-distribution values of Table 1, compute $F(x)$ at the x -positions corresponding to the flame-front arrival times, t , as follows:

$$F(x) = \frac{\dot{q}''_e(x)}{\dot{q}''_e(50)} \quad (3)$$

12.2.3 Calculate the surface flux at the measured flame-front positions from the flux $\dot{q}''_e(50)$ as recorded in 11.3.3, as follows:

$$\dot{q}''_e(x) = F(x) * \dot{q}''_e(50) \quad (4)$$

12.2.4 Compute flame-front velocity by applying a running three-point least square fit to the measured flame front position-time (x, t) data as follows:

$$V = \frac{\sum tx - \frac{\sum t \sum x}{3}}{\sum t^2 - \frac{(\sum t)^2}{3}} \quad (5)$$

12.2.5 Correlate and plot flame-spread data as shown in Fig. X1.2 (see also Eq X1.10 in Appendix X1) as follows:

$$V^{-1/2} \text{ versus } \dot{q}''_e(x) F(t) \quad (6)$$

where:

$$F(t) = \begin{cases} b \sqrt{t}, & t \leq t^* \\ 1, & t \geq t^* \end{cases} \quad (7)$$



E 1321 – 97a (2002)

FLAME-SPREAD DATA LOG

Test Identification: _____ Date: _____

Material: _____

Test No. _____ Specimen No. _____ Ambient Temperature _____ (°C)

Specimen Conditioning: Relative Humidity _____ Room Temperature _____ (°C)

Specimen Backing: _____ Density: _____ (kg/m³)

Flux Sensor No. _____ Calibration Factor _____ (kW mV/m²)

Flux Sensor Reading _____ (mV) _____ (kW/m²)

Pyrometer Reading _____ (mV) _____ (kW/m²)

Preheat Time: _____ (s)

Flame Front Position (mm)	Arrival Time (s)	Remarks:
Ignition Time _____		
50 _____		
100 _____		
150 _____		
175 _____		
200 _____		
225 _____		
250 _____		
275 _____		
300 _____		
325 _____		
350 _____		
375 _____		
400 _____		
425 _____		
450 _____		
475 _____		
500 _____		
525 _____		
550 _____		
575 _____		
600 _____		
625 _____		
650 _____		
675 _____		
700 _____		
725 _____		
750 _____		
775 _____		

FIG. 9 Data Logging Format Sample, Flame Spread Test

NOTE 6—The plotted velocity (V) and surface flux (q''_o) should represent values at the midpoint of the three points used for the data fit.

12.2.6 Fit line to linear section of data (see solid line Fig. X1.2). See Appendix X2 for the rationale for weighing the data points over the linear section of the data.

12.2.7 Obtain the following parameters:

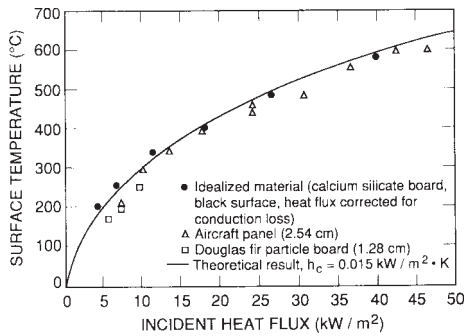

FIG. 10 Equilibrium Surface Temperature as a Function of External Radiant Heating

- C flame spread parameter (slope of straight line fitted to correlated flame spread data (see Fig. X1.2))
- $\dot{q}''_{o,ig}$ x intercept of straight line (see Fig. X1.2)
- T_{ig} from $\dot{q}''_{o,ig}$ and theoretical curve for surface temperature (see Eq X1.9, Fig. 10)
- $\dot{q}''_{o,s}$ flux at position where flame stops (see Fig. X1.2)
- $T_{s,min}$ from $\dot{q}''_{o,s}$ and theoretical curve for surface temperature at thermal equilibrium (see Eq X1.9 and Fig. 10)

12.2.8 Compute flame-spread parameter, Φ (see Eq X2.7 in Appendix X2), as follows:

$$\Phi = \frac{4}{(Cb)^2} \tag{8}$$

13. Report

13.1 Report the following information:

- 13.1.1 The date, the original ignition and flame spread data, the observations made on each specimen, and the derived ignition and flame spread parameters,
- 13.1.2 Name and address of the testing laboratory,
- 13.1.3 Identification of specimen including manufacturer and code designation, thickness, density, and where known, composition of the specimen,
- 13.1.4 Identification of specimen backing material including thickness, density, and where known, thermal conductivity,
- 13.1.5 Data from the ignition test including:
 - 13.1.5.1 A table or graph, or both, showing ignition times for external fluxes, and
 - 13.1.5.2 Measured and derived ignition parameters, as follows:

- $\dot{q}''_{o,ig}$ = flux necessary for ignition, min,
- T_{ig} = surface temperature necessary for ignition, min,
- b = ignition correlation parameter,
- t^* = time for specimen to reach thermal equilibrium, and
- kpc = thermal heating property,

13.1.6 Data from flame spread test including:

- 13.1.6.1 Surface flux at the 50-mm position,
- 13.1.6.2 Flame-front arrival time at 25-mm increments along specimen surface, and
- 13.1.6.3 Measured and derived flame spread parameters, as follows:

- C = flame spread parameter,
- $\dot{q}''_{o,ig}$ = flux necessary for ignition, min,
- T_{ig} = surface temperature necessary for ignition, min,
- $\dot{q}''_{o,s}$ = flux necessary for flame spread, min,
- $T_{s,min}$ = temperature necessary for flame spread, min, and
- Φ = flame heating parameter, and

13.1.7 Calibrated flux distribution along specimen surface at positions listed in Table 1.

TABLE 1 Calibration of Flux to the Specimen

NOTE 1—This table includes typical flux incident on the specimen and specimen positions at which the calibration measurements are to be made. The flux at 50 and 350-mm positions shall be set as accurately as possible. Calibration data at other positions shall agree with typical values within 10 %. This calibration shall be performed with the use of the special dummy specimen. It is possible to measure all except the first of the fifteen typical measurements listed.

Distance From Exposed End of the Specimen, mm	Typical Flux Levels at the Specimen, kW/m ²	Calibration Position to be Used, kW/m ^{2A}
0	49.5	
50	50.5	50.5
100	49.5	
150	47.1	X
200	43.1	
250	37.8	X
300	30.9	
350	23.9	23.9
400	18.2	
450	13.2	X
500	9.2	
550	6.2	X
600	4.3	
650	3.1	X
700	2.2	
750	1.5	X

^A An X indicates the fluxes at the additional six measuring positions required by the standard. The seven empty spaces represent the fluxes at the additional measuring positions recommended by the standard.

14. Precision and Bias

- 14.1 Precision—The precision of this test method is under consideration and is awaiting evaluation.
- 14.2 Bias—This test method for determining ignition and flame spread properties of materials has no bias because these values are effective properties derived from the test data. While these effective properties may have more precisely measurable physical counterparts, in this test method they are determined by a fit of the data to a model for flame spread.

ANNEX

(Mandatory Information)

A1. ASSEMBLY OF APPARATUS

A1.1 Assembly and Adjustment

A1.1.1 The heat-flux measurement at the surface of the specimen is the controlling criterion both in the original adjustment of test operating conditions and periodic verification of this adjustment. This heat flux shall be measured by a fluxmeter inserted into holes in a special calibration board (see Fig. A1.1).

A1.1.2 Monitor radiant-panel operating levels between consecutive tests by use of a heat fluxmeter mounted at the 50-mm position in a dummy specimen and during the test by use of a radiation pyrometer calibrated on the basis of the readings of a heat fluxmeter. The calibration should be periodically checked. This radiation pyrometer shall be rigidly fixed to the specimen holder frame in such a manner that it continuously views the radiating-panel surface (see 6.3.1).

A1.2 Mechanical Alignment

A1.2.1 The position of the refractory surface of the radiant panel with respect to the specimen must correspond with the angle and Dimension A shown in Fig. A1.2. These relationships are achieved by adjustment between the panel and its mounting bracket, the two main frames, and position of the specimen holder guides.

A1.2.2 With the apparatus assembled as specified in Section 6, make the following mechanical alignments:

A1.2.2.1 Check the rotating ring (see Fig. 6) with a level to ensure that it lies in a vertical plane. If the bearing does not lie in the vertical plane, adjust the upper support bracket. If any nonvertical position is caused by excessive bearing roller clearance, install larger rollers.

A1.2.2.2 With the radiant panel rotated into a vertical position (as checked with a level), the angle between the panel and the longitudinal members of the specimen support frame shall be $15 \pm 0.25^\circ$ (see Fig. A1.2).

A1.2.2.3 With an empty specimen holder installed, adjust the upper guide fork to ensure the holder lies in a vertical

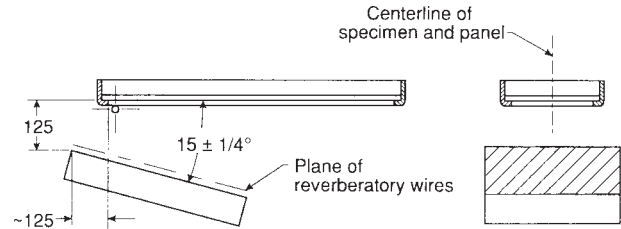

NOTE 1—All dimensions are in millimetres.

FIG. A1.2 Specimen-Panel Arrangement

plane. Adjust the spacing between the radiant panel and the holder frame so that Dimension A in Fig. A1.2 is 125 ± 2 mm while still maintaining the $15 \pm 0.25^\circ$ angular relationship. Dimension B must be adjusted to meet the flux distribution requirements along the specimen.

A1.2.2.4 Position the horizontal pilot as shown in Fig. 3.

A1.2.2.5 Position the viewing rake so that the pins are located at multiples of 50 ± 2 -mm distance from the closest end of the specimen exposed to the panel.

A1.3 Thermal Adjustment of Radiant Panel Operating Level

A1.3.1 Thermal adjustment of the panel operating level is achieved by first setting an air flow of about $0.26 \text{ m}^3/\text{s}$ through the panel. Gas is then supplied and the panel ignited and allowed to come to thermal equilibrium with a dummy specimen mounted before it. At proper operating condition there shall be no visible flaming from the panel surface except when viewed from one side parallel to the surface plane. From this direction a thin blue flame very close to the panel surface will be observed. An oblique view of the panel after a 15 min warm up period shall show a bright orange radiating surface.

NOTE A1.1—In the absence of a calibrated flowmeter in the air line, this flow rate can be roughly set by holding a lighted match with its axis horizontal and close to the burner-tile face. The flame from the match shall deviate from the vertical by about 10° .

A1.3.2 With a water-cooled fluxmeter mounted in the calibration board (see Fig. A1.1), the flux incident on the specimen shall correspond to the values shown in Table 1. Compliance with this requirement is achieved by adjustment of the air/gas flow rates. When required, changes in air and gas flow shall be made to achieve the condition of no significant flaming from the panel surface. In systems using a venturi valve, change the flux levels by adjusting only the air valve.

NOTE A1.2—**Caution:** Water cooling of the fluxmeter is required to avoid damage to the fluxmeter and erroneous signals at low flux levels. Control temperature of the cooling water in such a manner that the fluxmeter body temperature remains within a few degrees of room temperature. Correction of the flux measurement should be made for temperature differences between the fluxmeter body and room temperature. Failure to supply water cooling may result in thermal damage to the

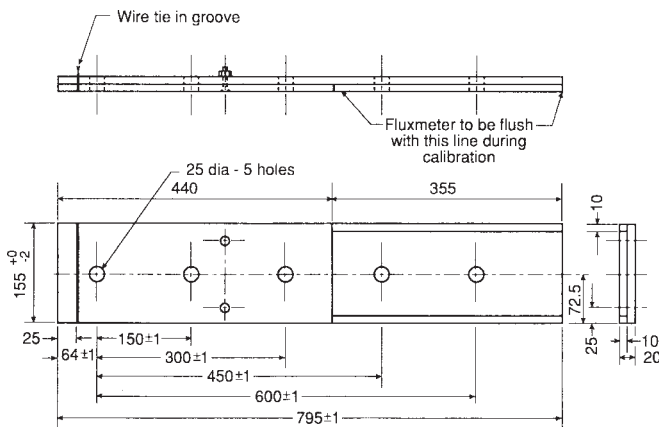

NOTE 1—All dimensions are in millimetres.

FIG. A1.1 Dummy Specimen for Flux Gradient Calibration

sensing surface and loss of calibration of the fluxmeter.

A1.3.2.1 The flux measured at both the 50 and 350-mm position shall match the values in Table 1 to ensure that a fixed configuration or view geometry between the panel and the specimen has been achieved. To meet these requirements, change the specimen longitudinal position shown by Dimension *B* in Fig. A1.2.

A1.3.2.2 Develop a plot and smooth curve on the basis of at least the eight required flux measurements shown in Table 1. On the basis of the normalized flux-distribution curve (see Fig. 2), the flux gradient along the specimen length is derived from a single flux measurement at the 50-mm position.

NOTE A1.3—It is recommended that the 15 measured flux levels at the positions shown in Table 1 be used to produce a smoother curve.

A1.3.2.3 If the radiation pyrometer is to be used to set the flux level at the 50-mm position, calibrate it over the operating range of 20 to 65 kW/m², on the basis of the reading of a fluxmeter positioned at the 50-mm position and the slope (*CF*), an apparatus constant, determined (see Fig. A1.3). Calculate

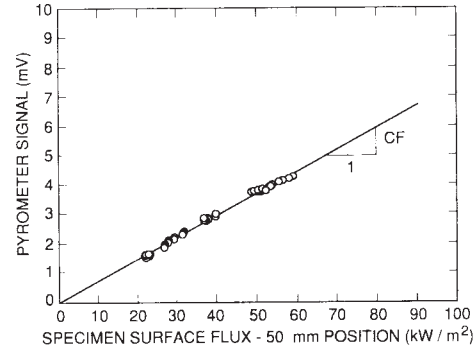

FIG. A1.3 Typical Calibration of Panel Output to Specimen Surface as a Function of Total Radiation Pyrometer Signal

the flux distribution along the specimen using *CF* or a fluxmeter reading at the 50-mm location (see 12.2.2 and 12.2.3). Once the relationship between the pyrometer millivolt output and the flux at 50 mm has been established, use either way to set the heat flux level.

APPENDIXES

(Nonmandatory Information)

X1. IGNITION THEORY (1)⁵

X1.1 The ignition theory is based on the following two reasonable assumptions:

X1.1.1 Most common organic solids, that is, those whose thermal diffusivity *k/ρc* fall in the range of 0 to 10⁻⁷ m²/s, in applications of construction can be treated as a semi-infinite solid since the depth of heating for conditions of piloted ignition is 2 to 5 mm. Even for materials of thickness smaller than this, the semi-infinite results apply if effective thermal properties for the assembly of the material and its substrate are considered. The same approach can be used for composite or nonhomogenous materials.

X1.1.2 Piloted ignition in an atmosphere of ambient-oxygen concentration occurs when the surface temperature of the material reaches a threshold value, *T_{ig}*, which depends on the material itself but is relatively independent of the way in which the material is heated. In other words, a sample of a certain material initially at ambient temperature and suddenly subjected to an external heat flux, will ignite with a pilot when its surface temperature reaches *T_{ig}*, irrespective of the heat-flux level (provided it is high enough to at least compensate for the heat losses). There is some experimental evidence for this assumption (2, 3).

X1.2 Consequently, the ignition theory can be formulated as a one-dimensional heat transfer problem in which a semi-infinite slab is subjected to an external radiant flux, *q''_e*.

Ignition occurs when the surface temperature, *T*, reaches *T_{ig}*. Fig. X1.1 shows the problem under study.

X1.2.1 For common building materials, the surface emissivity, *ε*, is close to one and can be assumed to be one. Also, the radiative part of the surface heat losses can be linearized. Thus, mathematically, the problem can be posed as follows:

$$\frac{\partial T}{\partial t} = \frac{k}{\rho c} \frac{\partial^2 T}{\partial y^2} \tag{X1.1}$$

$$y = 0: -k \frac{\partial T}{\partial y} = \dot{q}''_e - h_c(T - T_\infty) - \sigma(T^4 - T_\infty^4)$$

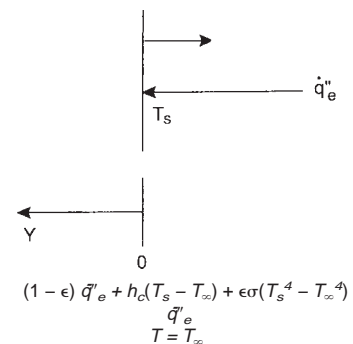

where:
ε = emissivity and
σ = Stefan-Boltzmann constant

FIG. X1.1 Model for Ignition Study

⁵ The boldface numbers in parentheses refer to the list of references at the end of this standard.

$$\cong \dot{q}''_e - h(T - T_\infty) \quad (X1.2)$$

$$y \rightarrow \infty: T = T_\infty \quad (X1.3)$$

$$t = 0: T = T_\infty \quad (X1.4)$$

The solution for this problem for the temperature at $y = 0$ can be written as follows:

$$T_s - T_\infty = \frac{\dot{q}''_e}{h} (1 - \exp(\tau) \operatorname{erfc}(\sqrt{\tau})) \quad (X1.5)$$

where:

$$\tau = \frac{h^2 t}{k\rho c} \quad (X1.6)$$

X1.2.2 At the minimum flux for piloted ignition, $\dot{q}''_{o,ig}$, theoretically ignition will occur for $t \rightarrow \infty$ when conductive losses into the material will be zero and heat losses from the surface will be equal to the external flux as follows:

$$\dot{q}''_{o,ig} = h(T_{ig} - T_\infty) \quad (X1.7)$$

Consequently Eq X1.5 can be rewritten at $t = t_{ig}$ and $T = T_{ig}$ using Eq X1.7 as follows:

$$\frac{\dot{q}''_{o,ig}}{\dot{q}''_e} = (1 - \exp(\tau) \operatorname{erfc}(\sqrt{\tau})) \quad (X1.8)$$

where τ is defined as in Eq X1.6, however with t being the piloted ignition time at \dot{q}''_e .

X1.2.3 The ignition temperature represents the surface temperature required to produce a flammable mixture just at the lower flammable limit for the ignition conditions under consideration. Although it is difficult to measure the surface temperature at ignition, it is possible to infer an (effective) ignition temperature by determining experimentally the critical radiative heat flux for piloted ignition, that is:

$$\dot{q}''_{o,ig} = h_c(T - T_\infty) + \sigma(T^4 - T_\infty^4) \cong h(T_{ig} - T_\infty) \quad (X1.9)$$

where here a black surface has been assumed.

X1.2.4 From experimental ignition tests, time to ignition, t , is measured at various levels of flux (\dot{q}''_e). By bracketing (see 11.2.11), the critical flux for ignition ($\dot{q}''_{o,ig}$) is determined. It has been found that for many materials (2-4), these experimental results can be correlated by the following relationship:

$$\frac{\dot{q}''_{o,ig}}{\dot{q}''_e} = F(t) = \begin{cases} b\sqrt{t}, & t \leq t^* \\ 1, & t \geq t^* \end{cases} \quad (X1.10)$$

The function $F(t)$ is the empirically determined counterpart to $[1 - \exp(\tau) \operatorname{erfc} \sqrt{\tau}]$ of Eq X1.11 and X1.12. The surface temperature rise as a function of time for Eq X1.1-X1.4 with negligible heat losses ($h = 0$) is proportional to \sqrt{t} . The zero heat loss condition is true immediately after insertion of the sample, but becomes less accurate as T_{ig} is approached. Yet, the experimental data on a wide range of materials show that the \sqrt{y} fit is acceptable. The higher \dot{q}''_e , the lower $\dot{q}''_{ig}/\dot{q}''_e$ and the smaller are the heat losses compared to \dot{q}''_e . Therefore on Fig. X1.2(a) for example, the lower points show the \sqrt{t} behavior while around t^* errors are larger and a \sqrt{t} fit becomes less accurate. Since Eq X1.11 and X1.12 were the result of a solution based on linearized heat loss, $F(t)$ should be considered the result for the actual heat loss experienced with the nonlinear radiative loss especially. It has been surprising but fortuitous that the simple functional form of Eq X1.1 has been

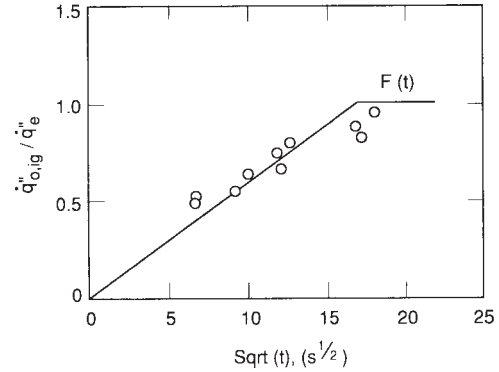

(a) Polycarbonate, $\dot{q}''_{o,ig} = 30 \text{ kW/m}^2$,

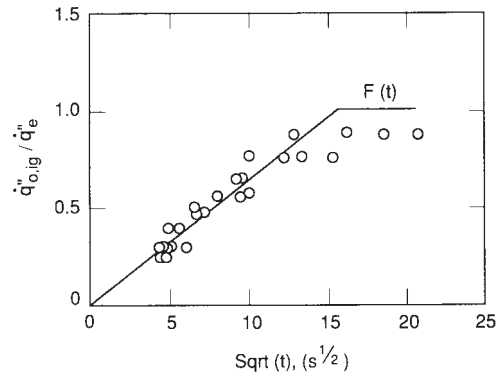

(b) Carpet, $\dot{q}''_{o,ig} = 18 \text{ kW/m}^2$

FIG. X1.2 Pilot Ignition Results Under Radiative Heating

satisfactory in many varied and complex materials. As t or $\tau \rightarrow \infty$, $1 - \exp(\tau) \operatorname{erfc} \sqrt{\tau}$ approaches 1 so that t^* in $F(t)$ can be regarded as a time to reach equilibrium or steady state in the material. Also as t or $\tau \rightarrow 0$, $1 - \exp(\tau) \operatorname{erfc} \sqrt{\tau}$ approaches $k\rho c$. Hence since $F(t)$ follows this behavior for $t \leq t^*$, it follows that:

$$b = \frac{2h}{\sqrt{\pi k\rho c}} \quad (X1.11)$$

Thus, $k\rho c$ can be derived as follows:

$$k\rho c = \frac{4}{\pi} \left(\frac{h}{b}\right)^2 \quad (X1.12)$$

The ignition data analysis yields the two effective properties, $k\rho c$ and T_{ig} , for a material. These should be applicable for both ignition and flame spread. Some examples of results (3) are shown in Fig. X1.2(a) and Fig. X1.2(b).

X1.2.5 These results were obtained in a vertical orientation in the flame-spread test apparatus where h_c was determined to be $15 \text{ kW/m}^2 \cdot \text{K}$ under conditions of natural convection (2-4). From Eq X1.9 the derived ignition temperature for the polycarbonate sample (see Fig. X1.2(a)) was found to be 528°C and for the carpet shown in Fig. X1.2(b) a value of 412°C was determined. Of course, accuracy cannot be ensured to three significant figures. Experimental tests show values range from as low as 280°C for a form of polymethylmethacrylate (PMMA) to 620°C for a fire-retarded plywood. Most materials seem to fall in a range of 350 to 450°C . Comparison with

measured values of surface temperature have been done on a limited basis with encouraging results. The measurement technique used has been described by Atreya et al (5). Tables X1.1 and X1.2 summarizes how these measured T_{ig} values compare with the inferred T_{ig} as derived from $\dot{q}''_{o,ig}$ and Eq. X1.14. The wood shown here and all other samples were tested

TABLE X1.1 Comparison of Measured and Derived Ignition Temperatures Under Radiative Heating

NOTE 1—The corresponding derived values for $k\rho c$ compared to values found in the literature at normal atmospheric temperatures (20 to 25°C) tend to be always higher. This is shown in Table X1.2 for the same materials.

Material	Radiative Heating, kW/m ²	Measured T_{ig} , °C	Derived T_{ig} , °C
Particle board	20 to 63	290 to 380	382
PMMA	16 to 46	285 to 330	378

TABLE X1.2 Comparison of Derived and Literature Values of $k\rho c$

NOTE 1—These results might be explained in terms of $k\rho c$ increasing with temperature and by overestimating the T_{ig} that then influences h in Eq X1.2 and X1.3. These variations in $k\rho c$ and T_{ig} should be considered acceptable for assessing ignition and subsequently flame spread when the empirical procedure is compared to the difficulty of measuring T_{ig} directly, especially for complex materials.

Material	Derived Value, (kW/m ² ·K) ² s	Literature Value (25°C), (kW/m ² ·K) ² s
PMMA	1.02	0.66
Particle board	0.93	0.14

under laboratory temperature and humidity that remained fairly constant at 20°C and 50 % relative humidity so that changes in results due to wide variations in moisture content have been minimized. Results are also shown for PMMA determined similarly.

X2. FLAME SPREAD THEORY (1)

X2.1 Many investigators have studied the theoretical and fundamental aspects of flame spread on a surface in a direction opposite to a directed flow of the environment (6-11). This is generally referred to as opposed flow flame spread. The opposed flow may be induced by the spreading flame itself due to buoyancy effects. This would be the case for downward or lateral spread on a wall or horizontal axisymmetric spread on a floor. The natural convection velocities should not vary greatly for small fire conditions and for typical flame temperatures can be estimated at 0 to 10 cm/s (7).

X2.2 Since most materials require external heating (under normal oxygen conditions) to enable flame spread, this will be a necessary part of a test to derive flame-spread data. The thermal theory for flame spread considered here has been discussed at length (1). The model diagram is shown in Fig. X2.1.

X2.2.1 The flame is spreading over the surface in the x -direction and is depicted as being blown by a wind. The fuel is burned out over region x_b , pyrolyzing over region $x_p - x_b$, and no degradation or vaporization occurs for $x > x_p$. The tip of the flame is given by x_f and the surface ahead of the pyrolyzing region receives most of the flame-heat transfer over this region ($x_f - x_p$). The initial temperature is given by T_∞ and the position where the temperature achieves the ignition temperature (T_{ig})

on the surface. Since external heat transfer is involved, the study considers a fixed position x and a one-dimensional conduction in the y -direction. The heat flux from the flame \dot{q}''_f is constant and uniform over the time period Δt before x_p reaches the position x ; the flame spread velocity $V_p = dx_p/dt$ is also constant in this period, and Δt is defined to be equal to $(x_f - x_p)/V_p$ where the flame heat flux is applied only over the region $x_f - x_p$. Quintiere (1) found the mathematical solution for V_p to be as follows:

$$V_p = \frac{(\dot{q}''_f)^2 (x_f - x_p)}{\frac{\pi}{4} k\rho c (T_{ig} - T_s)^2} \tag{X2.1}$$

$$\text{where } T_s - T_\infty = \frac{\dot{q}''_f(x_p)}{h} [1 - \exp(\tau) \operatorname{erfc} \sqrt{\tau}] \tag{X2.2}$$

or $T_s - T_\infty$ is the temperature rise due to the external heating.

X2.2.2 The solution derived by deRis (7) under steady conditions with consideration of the gas phase and solid fuel phase in two dimensions can be given as follows:

$$V_p = V_g \frac{(k\rho c)_g}{k\rho c} \left(\frac{T_f - T_{ig}}{T_{ig} - T_s} \right)^2 \tag{X2.3}$$

Here V_g is the opposed flow velocity, T_f is the flame temperature, and the subscript g denotes properties of the gas phase. Recently Wichmann (11) has developed an alternative model that has included effects of finite kinetics in the gas phase. This analysis changes the exponent in Eq X2.3 from 2 to 2.5 and primarily modifies the value of V_p by a function of a Damköhler number that brings into play needed kinetic data for the fuel. Roughly, if chemical kinetic effects are unimportant, then Eq X2.3 is adequate, but if kinetics are important, then the actual flame-spread speed is lower than that given by Eq X2.2. These results have been shown experimentally for

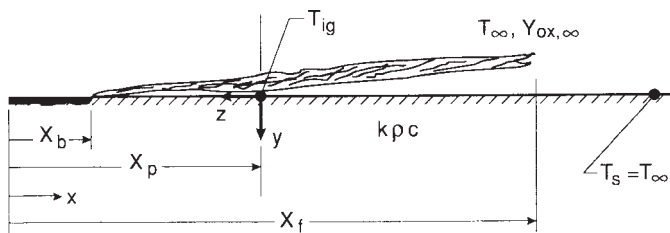

FIG. X2.1 Model for Flame Spread

thick (PMMA) and thin (paper) fuels over a wide range of flows (V_g), gravitational fields, and oxygen concentrations (6, 8, 10, 11).

X2.2.3 The problem with applying Eq X2.3 in general is the ability to determine the flame temperature for a complex material experiencing opposed flow flame spread. In comparing Eq X2.3 with Eq X2.1 it can be seen that the numerator suggests another property that could be sought for specific conditions of opposed flow spread. Here we consider lateral flame spread on a wall (3, 4, 12). By applying a variable decreasing external radiant-heat flux with distance from the ignitor, the flame will spread according to the local surface temperature, T_s . The data can ultimately be correlated by the following relationship:

$$V = \frac{\Phi}{k\rho c(T_{ig} - T_s)^2} \quad (X2.4)$$

where Φ is now a new material flame spread property. It should be a constant for a particular material under conditions of a fixed V_g and a fixed ambient oxygen concentration. Thus, under natural convection conditions in air, values for Φ were developed (3, 4). The results for lateral spread were also found in agreement for downward spread and horizontal axisymmetric spread (4) indicating the opposed flow velocities were similar. This suggests that Φ values derived under lateral spread could also apply to downward (provided melting is not significant) or horizontal spread under natural convection conditions.

X2.2.4 If Eq X2.3 is accepted as correct, where T_f is the actual flame temperature, then this value of T_f can be computed from the data for Φ . For the orientation of lateral spread apparatus it can be argued that natural convection prevails and V_g is weakly dependent on material through T_f . Selecting $T_f = 2080^\circ\text{C}$ for purposes of estimating V_g , gives 0.11 m/s (4, 7). Therefore, from Eq X2.3 and X2.4:

$$T_f = T_{ig} + \left(\frac{\Phi}{V_g(k\rho c)_g} \right)^{\frac{1}{2}} \quad (X2.5)$$

where $(k\rho c)$ is taken for air at normal temperature to be $3.3 \times 10^{-5} (\text{kW}/\text{m}^2 \cdot \text{K})^2 \text{s}$.

X2.2.5 The procedure for determining Φ requires several steps. Eq X2.4 can be rewritten making use of Eq X1.6-X2.4. This results in the following:

$$V_p(t)^{-\frac{1}{2}} = \left(\frac{h^2\Phi}{k\rho c} \right)^{-1/2} (\dot{q}''_{o,ig} - \dot{q}''_e F(t)) \quad (X2.6)$$

Here t refers to the time the pyrolysis front is at a position x and is the time over which \dot{q}''_e has acted at that same position. The empirically derived results from ignition, $F(t)$, allow accounting for the varying surface temperature over distance, x , and time, t . This technique has been successful in correlating a wide range of materials over a heat-flux range of 2 to 50 kW/m^2 with a wide range of heating times as well (3). Some illustrative results are shown in Fig. X2.2.

X2.2.5.1 The velocity was determined in Fig. X2.2 by analyzing the record of the pyrolysis front as a function of time. The lines have been drawn by weighing the data points over the center of the data. This is done for two reasons: V_p is not accurately determined as $\dot{q}''F(t)$ approaches the intercept

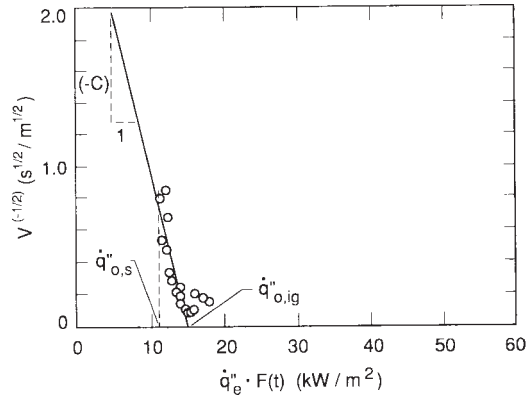

(a) Asphalt Shingle, $\dot{q}''_e F(t) (\text{kW}/\text{m}^2)$

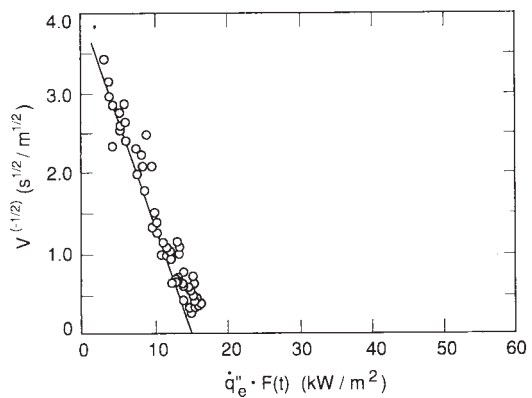

(b) Wool Carpet, $\dot{q}''_e F(t) (\text{kW}/\text{m}^2)$

FIG. X2.2 Correlations of Lateral Flame Spread

$\dot{q}''_{o,ig}$; and at the other extreme, extinction effects tend to cause some scatter and curvature in the results. It is interesting to note that this correlation provides a way to determine $\dot{q}''_{o,ig}$ independent of the ignition procedure of bracketing. It follows from Eq X1.3, Eq X1.5, Eq X2.4, and Eq X2.5 that:

$$\Phi = \frac{4}{\pi(Cb)^2} \quad (X2.7)$$

where C , the slope of the line through the data points, is a constant related to the term $(h^2\Phi/k\rho c)^{-1/2}$ of Eq X2.6. Results of these two materials are summarized in Table X2.1.

X2.2.6 Generally results for Φ have ranged from approximately 1 to 15 $(\text{kW})^2/\text{m}^3$ whereas a value of 0 to 10 $(\text{kW})^2/\text{m}^3$ could be estimated from Eq X2.1 using a theoretical flame

TABLE X2.1 Illustrative Results for Lateral Flame Spread

Material	$\dot{q}''_{o,ig}$ Ignition Data, kW/m^2	T_{ig} , $^\circ\text{C}$	$\dot{q}''_{o,ig}$ Spread Data, kW/m^2	Φ , $(\text{kW})^2/\text{m}^3$	T_f , $^\circ\text{C}$	$T_{s,min}$, $^\circ\text{C}$
Asphalt shingle	15	378	16	5.4	1590	140
Wool carpet (No. 2 treated)	20	435	16	7.3	1850	335
Wool carpet (No. 2 untreated)	22	455	16	0.89	950	365
PMMA	16	378	16	14.4	2370	<90

temperature and a characteristic velocity for natural convection of approximately 10 cm/s. Also shown in Table X2.1 are minimum temperatures for spread ($T_{s,\min}$) below which no propagation is observed. This cannot be explained theoretically, but must be governed by heat losses and chemical kinetic effects as the surface temperature decreases. The flame spread correlations of Fig. X2.2 show this lower limit for $\dot{q}''_e F(t)$ from which a corresponding temperature can be computed from Eq X1.5 and Eq X1.10, that is:

$$T_{s,\min} - T_\infty = \frac{1}{h} (\dot{q}''_e F(t)) \text{ lower limit} \quad (\text{X2.8})$$

where h is evaluated at $T_{s,\min}$ by Eq X1.7. Values of $T_{s,\min}$ range widely. For example, PMMA will allow lateral spread for

normal ambient temperatures, while for Douglas fir particle board $T_{s,\min} = 275^\circ\text{C}$, and for a fire retarded plywood $T_{s,\min} = T_{ig} = 620^\circ\text{C}$ so that no lateral flame spread was found to be possible.

X2.2.7 As can be seen in Fig. X1.2, $F(t)$ is only the best fit to the ignition data. In particular around t^* , heat losses become more important in comparison to \dot{q}''_e and $F(t)$ deviates more from the solution (see Eq X1.8). Therefore, the flame-spread data tend to give better correlation if the sample is preheated over a time, t^* , so that steady-state conditions can be assumed. The reasoning explained before remains valid, however $F(t)$ becomes equal to 1 in all the equations.

X3. COMMENTARY

X3.1 Introduction

X3.1.1 There are many different tests for assessing the flammability of materials (see Test Methods E 84, E 162, E 286, E 648, E 970, and E 1317). In most cases these tests are for the purpose of evaluating interior finish materials and products, particularly wall and ceiling applications. In general, all of the tests express their results in terms of some observations or measurements. These are then used to derive a relative ranking scale on which to evaluate materials. Unfortunately, the bases of these ranking scales are arbitrary, and therefore results from one test do not necessarily agree with another. Each test measures some combination or aspect of flammability; namely, ignition, flame spread, and energy release. But none attempts to relate its measured test results to theories of ignition, spread, or combustion. Consequently, the test results are limited in their use, but often widely applied.

X3.1.2 This practice is in sharp contrast to the evaluation of material performance in other fields. If there is interest in the heat transfer characteristics of materials, their thermal properties would be sought. If there is interest in the strength of materials, their modulus of elasticity and yield stress would be sought. Then an understanding of how the material is to be used would be sought and that configuration would be analyzed based on the principles of heat transfer or structural analysis. If the materials were complex in form, it would be expected that the property data were effective since the engineering analysis used would most likely be based on a model for simple homogeneous materials. For example, a measured thermal conductivity of a foam material would represent all the underlying heat-transfer processes in the foam. Its measured thermal conductivity would not be that of the pure material or the entrapped air in the foamed material, but it would be an effective value based on Fourier's law of heat conduction applied to the foam. Obviously, the effects on a material in a fire are more complex than this. But by using simple theories based on scientific analysis, we should be able to derive and utilize effective property data in an analogous fashion (13).

X3.2 Historical Aspects

X3.2.1 In 1968, the International Standards Organization (ISO) became interested in small scale tests as a means of

determining fire behavior of materials and initiated a study for an apparatus design and test procedure to evaluate ignitability and flame spread of materials. Several years later, the International Maritime Organization (IMO) became interested in the ISO spread of flame test method and initiated a more serious consideration for adopting the test method that resulted in years of apparatus development, testing, and study. In 1985, the Department of Transportation, Federal Aviation Administration (FAA) sponsored a study at the National Institute for Standards and Technology (NIST) to develop and analyze the measurement of flame-spread properties (3, 4). This test method is a result of that study.

X3.3 Scope

X3.3.1 This test method describes a procedure that utilizes the apparatus evolved from the ISO/IMO research and the scientific analysis process initiated by the FAA study to measure material flammability properties applicable to fire spread of materials on a vertically oriented surface.

X3.3.2 The apparatus utilizes a radiant-heat source capable of supplying up to 65 kW/m² to a vertically oriented specimen. The test results pertain to piloted ignition of a vertical specimen under constant and uniform irradiation and to lateral flame spread on a vertical surface due to an external applied heat flux. The test method may not be applicable to products that do not have planar, or nearly planar, external surfaces and those products and assemblies in which physical performance such as joint separation and fastening methods can significantly influence flame propagation in actual fire conditions.

X3.3.3 The properties derived from this test method provide information about the flame-spread characteristics of materials and can serve as an indication of their hazardous characteristics. The test results provide material fire parameters that correspond to property data required by theories of surface flame spread and ignition. In particular, these properties include: ignition temperature; minimum temperature for lateral spread; the product of density, specific heat and thermal conductivity; and the numerator of the governing equation for opposed flame spread under material convection conditions. The last property relates to the flame temperature or flame-heat transfer characteristics of the material.



X3.3.4 The analysis may be used to rank material performance by some set of criteria (14) applied to the correlation; or the analysis may be employed in fire risk growth models to

develop a more rational and complete risk assessment for wall materials.

REFERENCES

- (1) Quintiere, J. Q., "The Application of Flame Spread Theory to Predict Material Performance," *Journal of Research of the National Bureau of Standards*, Vol 93, Number 1, January–February, 1988, pp. 61–70.
- (2) Quintiere, J., Harkleroad, M., and Walton, W., "Measurement of Material Flame Spread Properties," *Combustion Science and Technology*, 1983, Vol 32, pp. 67–89.
- (3) Quintiere, J. G., and Harkleroad, M., "New Concepts for Measuring Flame Spread Properties," *NBSIR 84-2943*, National Bureau of Standards, Nov. 1984.
- (4) Quintiere, J. G., and Harkleroad, M., "New Concepts for Measuring Flame Spread Properties," *Fire Safety Science and Engineering*, ASTM STP 882, Harmathy, T. Z., ed., ASTM, 1985, pp. 239–267.
- (5) Atreya, A., Carpenter, C., and Harkleroad, M., "Effect of Sample Orientation on Piloted Ignition and Flame Spread," *Fire Safety Science Proceedings*, International Association for Fire Safety Science, First International Symposium, Grant, C. E., and Pagni, P. E., eds., Hemisphere Publishing Corp., NY, 1985, p. 97.
- (6) Fernandez-Pello, A. C., and Hirano, T., *Combustion Science and Technology*, Vol 32, 1983, p. 1.
- (7) deRis, J. N., *Twelfth International Symposium on Combustion*, The Combustion Institute, Pittsburgh, PA, 1969, p. 241.
- (8) Altenkirch, R. A., Eichhorn, R., and Shang, P. C., *Combustion and Flame*, Vol 37, 1980, p. 71.
- (9) Magee, R. S., and McAlevy, R. F. III, *Journal of Fire and Flammability*, Vol 2, 1971, p. 271.
- (10) Fernandez-Pello, A. C., Ray, S. R., and Glassman, I., *Eighteenth International Symposium on Combustion*, The Combustion Institute, Pittsburgh, PA, 1981, p. 579.
- (11) Wichman, I. S., *Combustion Science and Technology*, Vol 40, 1984, p. 223.
- (12) Quintiere, J. G., *Fire and Materials*, Vol 5, No. 2, 1981, pp. 52–60.
- (13) Quintiere, J. Q., "The Application of Flame Spread Theory to Predict Material Performance," *Fundamental Aspects of Polymer Flammability IOP Short Meetings Series Number 4*, Institute of Physics, Bristol, England, April 1987, p. 14.
- (14) Quintiere, J., "A Simplified Theory for Generalizing Results from a Radiant Panel Rate of Flame Spread Apparatus," *Fire and Materials*, Vol 5, No. 2, 1981.

ASTM International takes no position respecting the validity of any patent rights asserted in connection with any item mentioned in this standard. Users of this standard are expressly advised that determination of the validity of any such patent rights, and the risk of infringement of such rights, are entirely their own responsibility.

This standard is subject to revision at any time by the responsible technical committee and must be reviewed every five years and if not revised, either reapproved or withdrawn. Your comments are invited either for revision of this standard or for additional standards and should be addressed to ASTM International Headquarters. Your comments will receive careful consideration at a meeting of the responsible technical committee, which you may attend. If you feel that your comments have not received a fair hearing you should make your views known to the ASTM Committee on Standards, at the address shown below.

This standard is copyrighted by ASTM International, 100 Barr Harbor Drive, PO Box C700, West Conshohocken, PA 19428-2959, United States. Individual reprints (single or multiple copies) of this standard may be obtained by contacting ASTM at the above address or at 610-832-9585 (phone), 610-832-9555 (fax), or service@astm.org (e-mail); or through the ASTM website (www.astm.org).