



# Standard Test Methods for Cigarette Ignition Resistance of Components of Upholstered Furniture<sup>1</sup>

This standard is issued under the fixed designation E 1353; the number immediately following the designation indicates the year of original adoption or, in the case of revision, the year of last revision. A number in parentheses indicates the year of last reapproval. A superscript epsilon ( $\epsilon$ ) indicates an editorial change since the last revision or reapproval.

## 1. Scope

1.1 This is a fire-test-response standard.

1.2 These test methods are designed for the assessment of the resistance of upholstered furniture component assemblies to combustion after exposure to smoldering cigarettes under specified conditions.

1.3 The tests apply to upholstered furniture components—cover fabrics, interior fabrics, welt cords, decking materials, barrier materials, and filling or padding materials including but not limited to: battings of natural or man-made fibers, foamed or cellular filling materials, resilient pads of natural or man-made fibers, and loose particulate filling materials (such as shredded polyurethane or feathers and down).

1.4 The individual test methods and the materials to which they apply are as follows:

1.4.1 *Cover Fabric Test*—Applies to outer cover fabrics (see Sections 11 and 12).

1.4.2 *Interior Fabric Test*—Applies to interior fabrics used in intimate contact with outer fabrics (see Sections 13 and 14).

1.4.3 *Welt Cord Test*—Applies to welt cord (see Sections 15 and 16).

1.4.4 *Filling/Padding Component Test*—Applies to resilient materials used under the cover fabric in seats or in inside vertical walls (inside arm and inside backs) (see Sections 17 and 18).

1.4.5 *Decking Materials Test*—Applies to resilient materials used in the deck under loose cushions (see Sections 19 and 20).

1.4.6 *Barrier Materials Test*—Applies to materials that are intended to serve as a barrier between cover fabric and conventional polyurethane foam (see Sections 21 and 22).

1.5 The values stated in inch-pound units are to be regarded as the standard. The values given in parentheses are for information only.

1.6 *This standard is used to measure and describe the response of materials, products, or assemblies to heat and*

*flame under controlled conditions, but does not by itself incorporate all factors required for fire hazard or fire risk assessment of the materials, products, or assemblies under actual fire conditions.*

1.7 *This standard does not purport to address all of the safety concerns, if any, associated with its use. It is the responsibility of the user of this standard to establish appropriate safety and health practices and determine the applicability of regulatory limitations prior to use. For specific hazard statements, see Section 7.*

## 2. Referenced Documents

### 2.1 ASTM Standards:

E 176 Terminology of Fire Standards<sup>2</sup>

E 691 Practice for Conducting an Interlaboratory Study to Determine the Precision of a Test Method<sup>3</sup>

### 2.2 Federal Specifications:<sup>4</sup>

Fed.Spec. CCC-C-436-D, Cloth, Ticking, Twill, Cotton; Type I

## 3. Terminology

3.1 Definitions—For definitions of terms used in these test methods, refer to Terminology E 176.

### 3.2 Definitions of Terms Specific to This Standard:

3.2.1 *deck*—in upholstered furniture, the upholstered support under the seat cushion in a loose seat construction.

3.2.2 *obvious ignition*—pronounced continuous and self-sustaining combustion of the test system accompanied by rapid generation of heat and smoke. It is a matter of operator judgment based upon experience in this type of operation.

3.2.3 *upholstered*—covered with material (as fabric or padding) to provide a soft surface.

3.2.4 *upholstered furniture*—for the purpose of these test methods, a unit of interior furnishing that (1) contains any surface that is covered, in whole or in part, with a fabric or

<sup>1</sup> These test methods are under the jurisdiction of ASTM Committee E05 on Fire Standards and are the direct responsibility of Subcommittee E05.15 on Furnishings and Contents.

Current edition approved Jan. 10, 2002. Published April 2002. Originally published as E 1353 – 90. Last previous edition E 1353 – 99.

<sup>2</sup> *Annual Book of ASTM Standards*, Vol 04.07.

<sup>3</sup> *Annual Book of ASTM Standards*, Vol 14.02.

<sup>4</sup> Available from Standardization Documents Order Desk, Bldg. 4 Section D, 700 Robbins Ave., Philadelphia, PA 19111-5094, Attn: NPODS.

related upholstery cover material, (2) contains upholstery material, and (3) is intended or promoted for sitting or reclining upon.

3.2.5 *upholstery cover material*—the outermost layer of fabric or related material used to enclose the main support system or upholstery materials, or both, used in the furniture item.

3.2.6 *upholstery material*—the padding, stuffing, or filling material used in a furniture item, which may be either loose or attached, enclosed by an upholstery cover material, or located between the upholstery cover material and support system, if present.

3.2.6.1 *Discussion*—This includes, but is not limited to, material such as foams, cotton batting, polyester fiberfill, bonded cellulose, or down.

3.2.7 *welt*—the piping effect produced when welt cord and cover fabrics are sewn together for ornamental purposes to finish the edges between intersecting surfaces of upholstered furniture cushions, pillows, arms, or backs.

3.2.8 *welt cord*—the continuous small-diameter cylindrical material that is wrapped in fabric and sewn as part of the cover to make a welt edge on upholstered furniture.

#### 4. Summary of Test Method

4.1 These test methods consist of several tests used to evaluate the cigarette ignition resistance of component materials used in the manufacture of upholstered furniture. Each test involves a miniature assembly consisting of the component to be tested along with other specified materials, mounted on a plywood mock-up that resembles a small chair seat and back. The assembly is exposed to a lighted cigarette as an ignition source.

#### 5. Significance and Use

5.1 These test methods are intended to estimate the performance of upholstered furniture under conditions of exposure to a smoldering cigarette. This is accomplished by testing furniture component assemblies. However, interactions between components in production furniture are not necessarily predicted by component assembly testing.

5.2 These test methods are not intended to measure the performance of upholstered furniture under conditions of open flame exposure and do not indicate whether the furniture will resist the propagation of flame under severe fire exposure or when tested in a manner that differs substantially from the test standard.

5.3 The results obtained with a material component tested in mock-up, in accordance with these test methods, do not necessarily indicate the performance of the same material component in other geometric configurations, such as in full-size furniture.

#### 6. Apparatus and Materials

6.1 *Mini-Mock-Up Tester (MMT)* (see Fig. 1):

6.1.1 The mini-mock-up tester consists of a base with a centrally located guide and a stationary vertical panel, a movable horizontal carriage, and a removable vertical support panel.

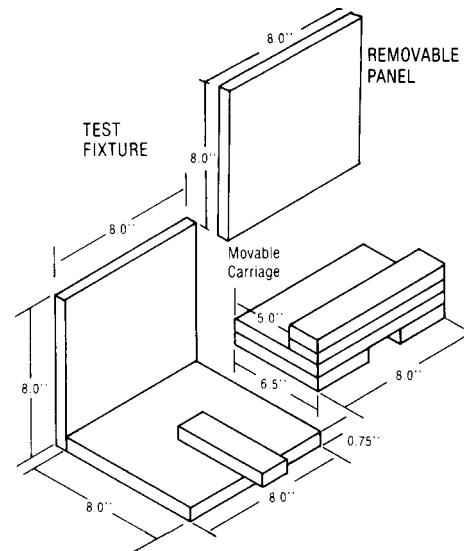


FIG. 1 Mini-Mock-Up Tester

6.1.2 The base consists of two wooden panels, each nominally 8 by 8 in. with nominal 0.75-in. thickness, joined together at one edge. The carriage has a 5 by 8-in. (125 by 203-mm) platform to support a horizontal specimen. The platform is 2.5 in. (38 mm) above the floor of the base and has a 1.5-in. (38-mm) lip at the front edge. The carriage is grooved to fit over a guide provided on the floor of the base. The removable vertical support panel consists of a wooden panel nominally 8 by 8 in. and with nominal 0.75-in. thickness, which stands against the vertical wall of the base.

6.2 *Decking Materials Tester (DMT)* (see Fig. 2)—The decking materials tester consists of a plywood base and a plywood retainer ring. The base measures 21 by 13.5 by 0.5 in. (533 by 343 by 13 mm). The retainer ring measures 21 by 13.5 by 0.5 in. with an opening measuring 16 by 8.5 in. (406 by 216 mm).

6.3 *Ignition Source*, consisting of cigarettes without filter tips, made from natural tobacco,  $3.4 \pm 0.1$  in. ( $85 \pm 2$  mm) long with a packing density of  $0.156 \pm 0.012$  oz/in.<sup>2</sup> ( $0.270 \pm 0.020$  g/cm<sup>2</sup>) and a total weight of  $0.039 \pm 0.004$  oz ( $1.1 \pm 0.1$  g). The smoldering rate of this cigarette shall be  $0.236 \pm 0.024$  in./min ( $0.10 \pm 0.01$  mm/s) when the cigarette is allowed to burn downward in a draft-protected area.

NOTE 1—With the cigarette supported at the bottom in a vertical position, the burning rate is determined in the region from 0.39 to 1.97 in. (10 to 50 mm) measured from the top.

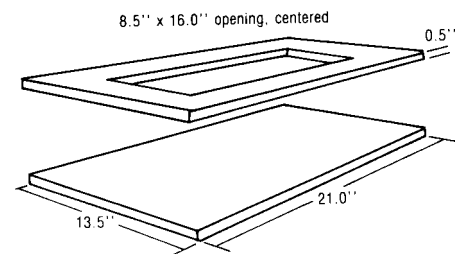


FIG. 2 Decking Materials Tester

6.4 *Standard Type I Cover Fabric*—The standard Type I cover fabric shall be 100 % cotton mattress ticking conforming to Fed. Spec. CCC-C-436-D. It shall be laundered and tumble-dried once before using.

6.5 *Standard Type II Cover Fabric*—The standard Type II cover fabric shall be UFAC standard Type II, 100 % bright regular rayon, scoured, 20/2, ring spun, basketweave construction,  $8.0 \pm 0.5 \text{ oz/yd}^2$  ( $271 \pm 12 \text{ g/m}^2$ ), undyed, containing no flame-retardant finishes or back coating.

6.6 *Sheeting Material*—The sheeting material to cover the test cigarettes shall be 50 % cotton/50 % polyester or 100 % cotton bed sheeting material weighing  $3.7 \pm 0.8 \text{ oz/yd}^2$  ( $125 \pm 28 \text{ g/m}^2$ ). The material shall be laundered in an automatic home clothes washing machine and dried in a tumble drier at least once before use. For testing, the sheeting material shall be cut into pieces approximately 5 by 5 in. (12.5 by 12.5 cm).

6.7 *Standard Polyurethane Foam Substrate*—The standard polyurethane foam substrate shall be open-celled polyether-type urethane, containing no inorganic fillers or flame retardants, having a density of 1.3 to 1.6 lb/ft<sup>3</sup> (20 to 25 kg/m<sup>3</sup>).

6.8 *Miscellaneous*—Other apparatus required to carry out the testing are: straight pins, a staple gun, a knife or scissors, tongs, and a linear scale graduated in millimeters and tenths of an inch.

6.9 *Air Velocity*—Air velocity across the test assemblies shall be maintained below 50 ft/min (15.2 m/min) in order to minimize localized effects from draft superheating of cigarette embers.

NOTE 2—A fume hood with air curtains across the face and zero air velocity at the test locations is recommended. Zero air velocity is indicated by an undisturbed vertical smoke plume of 6 in.

6.10 *Extinguishing Equipment:*

6.10.1 *Pressurized Water Fire Extinguisher*, or other suitable fire extinguishing equipment, immediately available.

6.10.2 *Water Bottle*, fitted with a spray nozzle to extinguish any ignited portions of the test specimen.

6.10.3 *Bucket of Water*, for immersing smoldering or burning materials removed from the tester.

6.10.4 *Tongs*, to handle smoldering materials prior to immersion.

6.10.5 *Gloves.*

6.10.6 *Breathing apparatus.*

6.11 *Draft-Free Enclosure*—An open draft preventive enclosure shall be provided and used to restrict airflow to convection only (see Fig. 3).

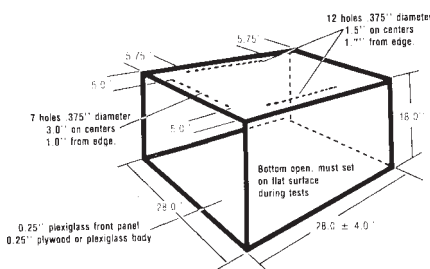


FIG. 3 Draft Enclosure

7. Hazards

7.1 **Warning**—Even under the most carefully observed conditions, smoldering combustion can progress to a point where it cannot be readily extinguished. It is imperative that a test be discontinued as soon as continuing combustion has definitely occurred. Immediately wet the exposed area with a water spray from the water bottle, remove the charred or burned material, and immerse the material in a bucket of water. Ventilate the test area.

7.2 Products of combustion can be irritating and dangerous to test personnel. Test personnel must avoid exposure to smoke and gases produced during testing as much as possible. A large hood with a low air velocity may be in operation during testing to remove products of combustion.

8. Conditioning

8.1 Condition all test upholstery fabrics and test materials (including polyurethane, cigarettes, and sheeting material) at a temperature of  $70 \pm 5^\circ\text{F}$  ( $21 \pm 2.8^\circ\text{C}$ ) and less than 65 % relative humidity for at least 24 h prior to testing. If the test room conditions do not meet the specifications above for the conditioning room, then the testing shall be initiated within 10 min after the specimens are removed from the conditioning room.

9. Report

9.1 Report the following information for each component:

9.1.1 Test procedure used,

9.1.2 Total number of cigarettes applied,

9.1.3 Whether ignition occurred,

9.1.4 Individual maximum lengths for each specimen, measured to the nearest 0.1 in. (0.2 cm),

9.1.4.1 Measurements exceeding 2 in. (5.1 cm) shall be reported as follows: >2 in.,

9.1.5 Whether Class A or Class B, and

9.1.6 Test room conditions.

10. Precision and Bias

10.1 *Precision*—The precision for measuring cigarette ignition resistance classification has not been determined. Results of a planned interlaboratory test series will be included when available.

10.2 *Bias*—The true value of cigarette ignition resistance classification of upholstered furniture components can only be defined in terms of a test method. Within this limitation, these test methods have no known bias and are generally accepted as referee methods.

COVER FABRIC TEST

11. Test Specimen

11.1 Cut three specimens, each 8 by 8 in. (203 by 203 mm), from the material to be tested for horizontal panels, and three specimens, 8 by 15 in. (203 by 381 mm), for vertical panels.

11.2 Cut each specimen with its long dimension in the direction of the warp and assembled for testing in a warp-to-warp orientation, such that the major areas of weave variation will lie in the crevice of the assembled test apparatus.

11.3 For fabrics with complex weaves, cut specimens so that portions of the three largest areas of weave complexity are contacted by the cigarettes placed on the test assemblies. For dyed or printed fabrics, or both, color shall not constitute a difference with respect to cigarette ignition resistance in this test.

**12. Procedure**

12.1 For horizontal panels, place the 8 by 8-in. (203 by 203-mm) cover fabric specimen on an 8 by 5 by 2-in. (203 by 127 by 51-mm) polyurethane substrate as shown in Fig. 4, and pin the ends of the fabric specimens to hold them in place.

12.2 For vertical panels, place the 8 by 15-in. (203 by 381-mm) fabric specimen on an 8 by 8 by 2-in. (203 by 203 by 51-mm) polyurethane substrate as shown in Fig. 4. The fabric shall overlap the top and bottom of the substrate and be pinned into place on the corners. The warp or machine direction of the fabric shall run from front to back on the test assembly.

12.3 Place each assembled vertical and horizontal panel in a mini-mock-up tester as shown in Fig. 4.

12.4 Mark the position of the crevice on the sides of the vertical substrate.

12.5 Light three cigarettes and place a lighted cigarette on each of the three test assemblies so that the cigarette lies in the crevice and against the vertical panel with equal distance of cigarette ends from either side of the assembly.

12.6 Place a piece of sheeting material over each cigarette, smoothing it over the cigarette to ensure intimate contact. Pin the sheeting to the vertical panel about 2.5 in. (63 mm) above the crevice.

NOTE 3—A finger run over the covered cigarettes ensures a good fabric-to-cigarette contact.

12.7 Allow the cigarettes to burn their full lengths unless an obvious ignition of the polyurethane substrate occurs. If a cigarette extinguishes before burning its entire length, place a fresh cigarette on a new test assembly and cover with sheeting fabric until either (1) three cigarettes have burned their entire

length on three individual test specimens, or (2) three cigarettes have self-extinguished on the specimen.

12.8 If continuing ignition occurs (that is, fabric and filling materials are ignited and are smoldering and generating smoke at a rapid rate), there is no need to wait until a cigarette has burned its full length. Stop the test and extinguish the burning material. Ventilate the test room and record an ignition for the cigarette test location.

12.9 If no obvious ignition occurs, record the vertical char on the vertical panel, to the nearest 0.1 in. (2.5 mm), measured from the original crevice position to the highest part of the destroyed or degraded fabric. Determine the original crevice position by laying a straightedge or ruler between the two marks previously marked on the edges of the vertical panel. The highest point of destroyed or degraded fabric is defined as the highest point at which any of the fabric is charred from front to back.

12.10 Classify those fabrics that do not develop obvious ignition (see 12.8) and exhibit a vertical char (see 12.9) of less than 1.8 in. (45 mm) as Class I. Classify fabrics developing obvious ignition or vertical char of 1.8 in. or more as Class II.

**INTERIOR FABRIC TEST**

**13. Test Specimen**

13.1 Cut three specimens, each 8 by 8 in. (203 by 203 mm) from the material to be tested.

13.2 Cut three specimens, each 8 by 8 in. (203 by 230 mm), and three specimens, each 12 by 12 in. (305 by 305 mm), from the standard Type I cover fabric.

**14. Procedure**

14.1 For horizontal panels, place the 8 by 8-in. (203 by 203-mm) piece of interior fabric and an 8 by 8-in. piece of standard Type I cover fabric with the interior fabric against the 8 by 5 by 2-in. (203 by 127 by 51-mm) standard polyurethane substrate as shown in Fig. 5, and pin the ends of the fabric specimen to hold it in place.

14.2 For vertical panels, place the 12 by 12-in. (305 by 305-mm) standard Type I cover fabric on an 8 by 8 by 2-in. (203 by 203 by 51-mm) standard polyurethane substrate as shown in Fig. 5. Pull the cover fabric around the edges of the panel and staple to the backside 1 in. (25 mm) from each edge.

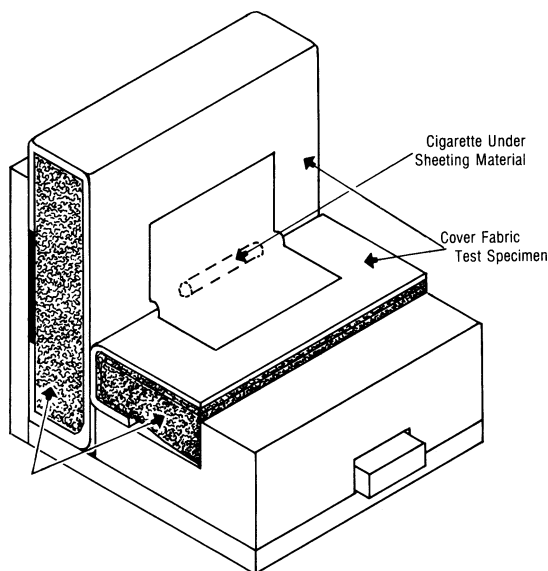
14.3 Place each assembled vertical and horizontal panel in a mini-mock-up tester as shown in Fig. 5.

14.4 Mark the position of the crevice on the sides of the vertical polyurethane substrate.

14.5 Light three cigarettes and place a lighted cigarette on each of the three test assemblies so that the cigarette lies in the crevice and against the vertical panel with equal distance of cigarette ends from either side of the assembly.

14.6 Place a piece of sheeting material over each cigarette, smoothing it over the cigarette to ensure intimate contact. Pin the sheeting to the vertical panel about 2.5 in. (63 mm) above the crevice (Note 3).

14.7 Allow the cigarettes to burn their full lengths unless an obvious ignition of the polyurethane substrate occurs. If a cigarette extinguishes before burning its entire length, place a fresh cigarette on a new test assembly and cover with sheeting



**FIG. 4 Cover Fabric Classification Test Method**

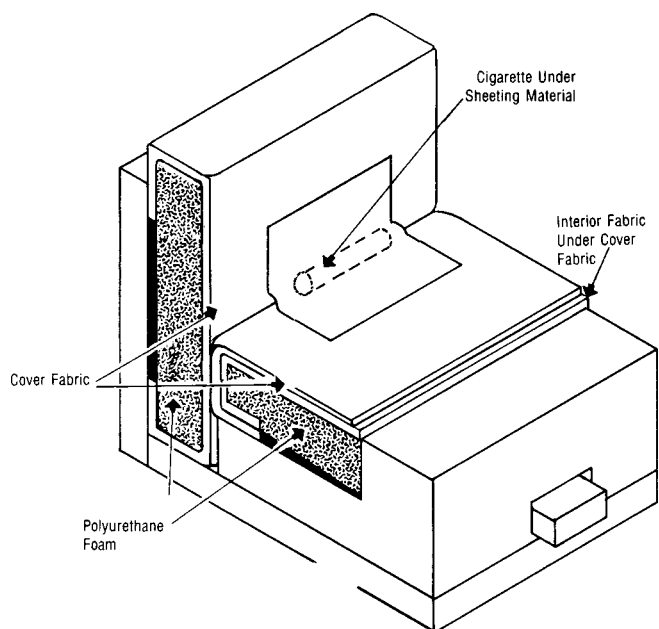


FIG. 5 Interior Fabric Test Method

fabric until either (1) three cigarettes have burned their entire length on three individual test specimens, or (2) three cigarettes have self-extinguished on the specimen.

14.8 If continuing ignition occurs (that is, fabric and filling materials are ignited and are smoldering and generating smoke at a rapid rate), there is no need to wait until a cigarette has burned its full length. Stop the test and extinguish the burning material. Ventilate the test room and record an ignition for the cigarette test location.

14.9 If no obvious ignition occurs, record the vertical char on the vertical panel to the nearest 0.1 in. (25 mm), from the original crevice position to the highest part of the destroyed or degraded interior fabric. Determine the original crevice position by laying a straightedge or ruler between the two marks previously marked on the vertical polyurethane substrate. The highest point of destroyed or degraded fabric is defined as the highest point at which any of the fabric is charred from front to back.

14.10 Classify those fabrics that do not develop obvious ignition (see 14.9) and exhibit a vertical char length (see 14.8) of less than 1.5 in. (38 mm) as Class A. Classify fabrics that develop obvious ignition or exhibit a char length of greater than 1.5 in. (38 mm) as Class B.

### WELT CORD TEST

#### 15. Test Specimen

15.1 Cut three 8 in. (203 mm) long specimens from the welt cord to be tested.

15.2 Cut three pieces of the standard Type II cover fabric, each 8 by 8 in. (203 by 203 mm), for horizontal panels, three pieces, each 8 by 15 in. (203 by 381 mm), for vertical panels, and three pieces, each by 1.5 in. (203 by 37 mm) or a width sufficient to allow 0.5-in. (13-mm) tails to extend below the welt. (Width of the welt may have to be adjusted to the size of the welt cord.)

#### 16. Procedure

16.1 For horizontal panels, place the 8 by 8-in. (203 by 203-mm) Type II cover fabric on an 8 by 5 by 2-in. (203 by 127 by 51-mm) standard polyurethane substrate as shown in Fig. 6, and pin the ends of the fabric specimens to hold them in place.

16.2 For vertical panels, place the 8 by 15-in. (203 by 381-mm) Type II cover fabric on an 8 by 8 by 2-in. (203 by 203 by 51-mm) standard polyurethane substrate as shown in Fig. 6. The fabric shall overlap the top and bottom of the substrate and be pinned into place in the corners.

16.3 Place each assembled vertical and horizontal panel in a mini-mock-up tester as shown in Fig. 6.

16.4 Place a welt cord specimen into the center of a folded strip of standard Type II cover fabric, to make an unsewn welt. Place an unsewn welt in each test assembly so that the fabric edges are between the horizontal and vertical panels and are held tightly in place by the panels (see Fig. 5).

16.5 Mark the position of the top of the welt on the sides of the vertical polyurethane substrate.

16.6 Light three cigarettes and place a lighted cigarette on each of the three test assemblies so that the cigarette lies on the welt and against the vertical panel with equal distance of cigarette ends from either side of the assembly.

16.7 Place a piece of sheeting material over each cigarette, smoothing it over the cigarette to ensure intimate contact. Pin the sheeting to the vertical panel about 2.5 in. (63 mm) above the crevice (Note 3).

16.8 Allow the cigarettes to burn their full lengths. If a cigarette self-extinguishes before burning its full length, place a fresh cigarette on a new test assembly and cover with sheeting fabric until either (1) three cigarettes have burned their full lengths on three individual specimens, or (2) three cigarettes have self-extinguished on the sample.

16.9 If continuing ignition occurs (that is, fabric and filling materials are ignited and are smoldering and generating smoke

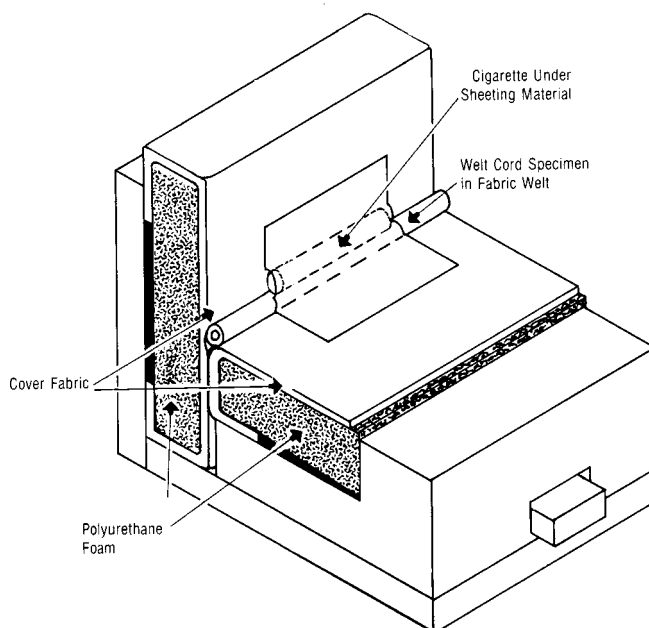


FIG. 6 Welt Cord Test Method

at a rapid rate), there is no need to wait until a cigarette has burned its full length. Stop the test and extinguish the burning material. Ventilate the test room and record an ignition for the cigarette test location.

16.10 If no obvious ignition occurs, record the vertical char on the vertical panel from the top of the original welt position to the highest part of the destroyed or degraded fabric. Determine the top of the original welt position by laying a straightedge or ruler between the two marks previously marked on the edges of the vertical panel. The highest point of destroyed or degraded fabric is defined as the highest point at which any of the fabric is charred from front to back.

16.11 Classify cords that do not develop obvious ignition (see 16.9) and exhibit a vertical char length (see 16.10) of less than 1.5 in. (38 mm) as Class A. Classify cords that develop obvious ignition or exhibit a vertical char length of greater than 1.5 in. (38 mm) as Class B.

### FILLING/PADDING COMPONENT TEST

#### 17. Test Specimen

17.1 Cut three specimens, each 8 by 5 by 2 in. (203 by 127 by 51 mm), for the horizontal panels, and three specimens, each 8 by 8 by 2 in. (203 by 203 by 51 mm), for the vertical panels.

17.2 For loose or particulate materials (shredded polyurethane, down, etc.) sew bags of the above dimensions, using the same ticking or any other materials, or both, to be used in manufacturing the finished piece of furniture.

NOTE 4—The packing density of the loose padding material should be as close as possible to that in the production furniture; test results can depend greatly on the packing density.

17.3 Cut three pieces, each 8 by 8 in. (203 by 203 mm), from the standard Type I cover fabric for horizontal panels, and three pieces, each 12 by 12 in. (305 by 305 mm), for vertical panels.

#### 18. Procedure

18.1 Construct three horizontal panels by wrapping each horizontal specimen panel with a piece of standard Type I cover fabric so that the top surface is completely covered and the warp direction of the fabric continues over the crevice edge and partially covers the bottom surface. Pin the cover fabric in place, at the top and bottom (see Fig. 7).

18.2 Construct three vertical panels by covering one surface of a removable vertical support panel with the vertical pad of the test specimen followed by the standard Type I cover fabric. Pull the standard Type I cover fabric around the edges of the panel and staple to the backside.

18.3 Place each assembled horizontal and vertical panel in a mini-mock-up tester as shown in Fig. 6 so that a snug fit is obtained between the two panels and the fabric orientation is warp-to-warp.

18.4 Mark the position of the crevice on the edges of the cover fabric.

18.5 Light three cigarettes and place a lighted cigarette on each of the three test assemblies so that the cigarette lies in the crevice and against the vertical panel with equal distance of cigarette ends from either side of the assembly.

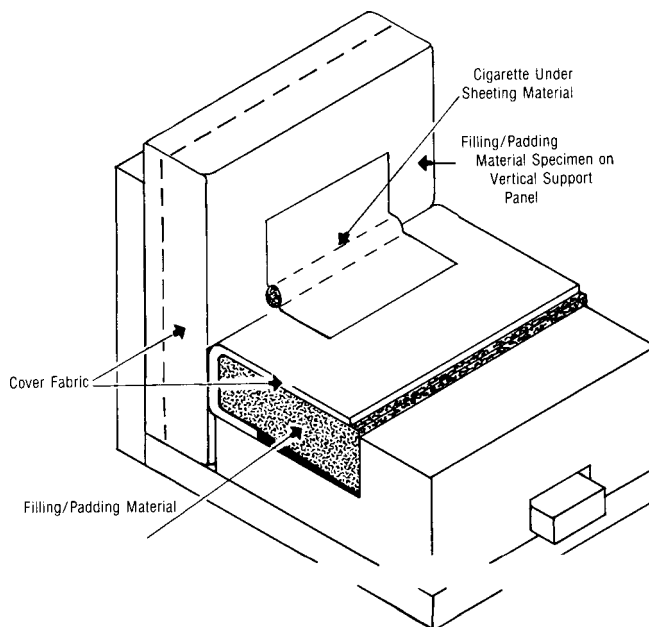


FIG. 7 Filling/Padding Component Test Method

18.6 Place a piece of sheeting material over each cigarette, smoothing it over the cigarette to ensure intimate contact. Pin the sheeting to the vertical panel about 2.5 in. (63 mm) above the crevice (Note 3).

18.7 Allow the cigarettes to burn their full lengths unless an obvious ignition of the substrate occurs. If a cigarette extinguishes before burning its entire length, place a fresh cigarette on a new test assembly and cover with sheeting fabric until either (1) three cigarettes have burned their entire length on three individual test specimens, or (2) three cigarettes have self-extinguished on the sample.

18.8 If continuing ignition occurs (that is, fabric and filling materials are ignited and are smoldering and generating smoke at a rapid rate), there is no need to wait until a cigarette has burned its full length. Stop the test and extinguish the burning material. Ventilate the test room and record an ignition for the cigarette test location.

18.9 If no obvious ignition occurs, record the vertical char on the vertical panel measured from the original crevice position to the highest part of the destroyed or degraded fabric. Determine the original crevice by laying a straightedge or ruler between the two marks previously marked on the edges of the cover fabric.

18.10 Classify fillings/paddings that do not develop obvious ignition (see 18.8) and exhibit a vertical char length (see 18.9) of less than 1.5 in. (38 mm) as Class A. Classify fillings/paddings that develop obvious ignition or exhibit a vertical char length of greater than 1.5 in. (38 mm) as Class B.

### DECKING MATERIALS TEST

#### 19. Test Specimen

19.1 Cut one specimen 21 by 13.5 in. (533 by 343 mm) and at least 1 in. (25 mm) thick from the decking material to be tested. If sample thickness is less than 1 in. (25 mm), use multiple layers in this test to make up the required thickness.

19.2 Cut one piece, 21 by 13.5 in. (533 by 343 mm), from the standard Type II fabric.

**20. Procedure**

20.1 Place the decking material specimens on the plywood base of the decking materials tested and cover with the standard Type II fabric. Place the plywood retainer ring on top of the cover fabric as shown in Fig. 8.

20.2 Light three cigarettes and place on the surface of the standard Type II fabric so that they are equally spaced from each other and from the edges of the retainer ring.

20.3 Place a piece of sheeting material over each of the cigarettes and smooth over the cigarette to ensure intimate contact.

20.4 Allow the cigarettes to burn their full lengths. If a cigarette extinguishes before burning its entire length, place another cigarette on a fresh area of the standard cover fabric until either (1) three cigarettes have burned their entire lengths, or (2) three cigarettes have self-extinguished.

20.5 If continuing ignition occurs (that is, fabric and filling materials are ignited and are smoldering and generating smoke at a rapid rate), there is no need to wait until a cigarette has burned its full length. Stop the test and extinguish the burning material. Ventilate the test room and record an ignition for the cigarette test location.

20.6 If no ignition occurs, measure the maximum length of char from the original cigarette position, and record to the nearest 0.1 in. (2.5 mm).

20.7 Classify decking that does not develop obvious ignition (see 20.5) and exhibits a char length (see 20.6) of less than 1.5 in. (38 mm) as Class A. Classify decking that develops obvious ignition or exhibits a char length of greater than 1.5 in. (38 mm) as Class B.

**BARRIER MATERIALS TEST**

**21. Test Specimen**

21.1 Cut three specimens, each 8 by 8 in. (203 by 203 mm), for horizontal panels from the material to be tested, and three specimens, each 8 by 15 in. (203 by 381 mm), for vertical panels.

21.2 Cut three pieces, each 8 by 8 in. (203 by 203 mm), from the standard Type II cover fabric for horizontal panels and three pieces, each 8 by 12 in. (203 by 305 mm), for vertical panels.

**22. Procedure**

22.1 For horizontal panels, place a barrier specimen on an 8 by 5 by 2-in. (203 by 127 by 51-mm) polyurethane substrate. Fold the barrier around and under the polyurethane as shown in Figs. 4-6 and fasten in place with pins. Place the 8 by 8-in. (203 by 203-mm) cover fabric over each barrier and fasten in place with pins.

22.2 For vertical panels, place a barrier specimen on an 8 by 8 by 2-in. (203 by 203 by 51-mm) polyurethane substrate. Place the 8 by 12-in. (203 by 305-mm) piece of cover fabric over each and fasten in place with pins as shown in Fig. 9.

22.3 Place each assembled horizontal panel and vertical panel in the test assembly so that fabric orientation is warp-to-warp. Firm contact must be achieved across the entire crevice formed by horizontal and vertical panels and there should be no deformation of the barrier material. If necessary, place a staple or thumb tack on the base guide to keep the horizontal panel in its initial position.

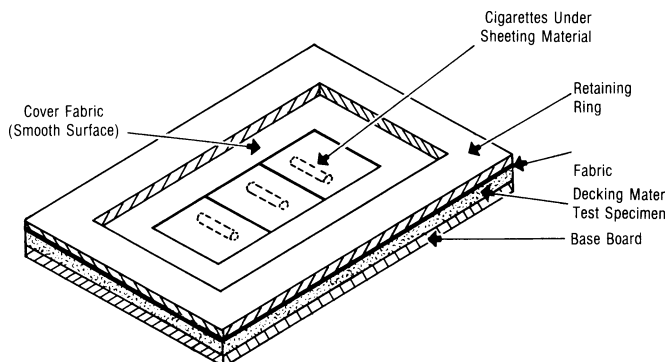
22.4 Mark the position of the crevice on the side of the vertical polyurethane substrate.

22.5 Light three cigarettes and place a lighted cigarette on each of the test assemblies so that the cigarette lies in the crevice and against the vertical panel with equal distance of cigarette ends from either side of the assembly.

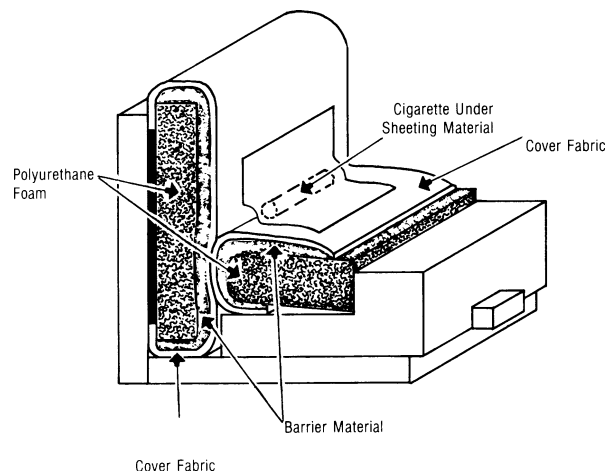
22.6 Place a piece of sheeting material over each cigarette, smoothing it over the cigarette to ensure intimate contact. Pin the sheeting to the vertical panel about 2.5 in. (63 mm) above the crevice (Note 3).

22.7 Allow the cigarettes to burn their full lengths unless an obvious ignition of the substrate occurs. If a cigarette extinguishes before burning its entire length, place a fresh cigarette on a fresh area of the test assembly and cover with sheeting fabric until either (1) three cigarettes have burned their entire length on three individual test specimens or (2) three cigarettes have self-extinguished on the sample.

22.8 If continuing ignition occurs (that is, fabric and filling materials are ignited and are smoldering and generating smoke at a rapid rate), there is no need to wait until a cigarette has burned its full length. Stop the test and extinguish the burning material. Ventilate the test room and record an ignition for the cigarette test location.



**FIG. 8 Decking Materials Test Method**



**FIG. 9 Barrier Materials Test Method**

22.9 If no obvious ignition occurs, record the vertical char on the vertical panel to the nearest 0.1 in. (2.5 mm), measured from the original crevice position to the highest part of the destroyed or degraded cover fabric. Determine the original crevice position by laying a straightedge or ruler between the two marks previously marked on the edges of the vertical panel. The highest point of destroyed or degraded fabric is defined as the highest point at which any of the fabric is charred from front to back.

22.10 Classify barrier materials that do not develop obvious ignition (see 22.8) and exhibit a char length (see 22.9) of less than 2.0 in. (51 mm) as Class A. Classify materials that develop obvious ignition or exhibit a char length of greater than 2.0 in. (51 mm) as Class B.

### 23. Precision and Bias

#### 23.1 Precision:

23.1.1 An interlaboratory evaluation was performed to provide an estimate of the precision of the test method, wherein 5 laboratories tested 5 systems, each with 8 different fabrics. The individual fabrics in each class are identified as Sample 1 through 8 on Tables 1 and 2. The systems tested, in triplicate, are as shown in 23.1.1.1-23.1.1.5.

23.1.1.1 Fabric class urethane form.

23.1.1.2 Barrier 1 in. PE/FR cotton.

23.1.1.3 Barrier 1 in. PE/foam.

23.1.1.4 Decking test FR cotton.

23.1.1.5 Decking test foam.

23.1.2 The statistical analyses for repeatability and reproducibility were conducted in two ways: based on actual measurements of char length (as the standard requires, see 23.1.3) and based on pass/fail (see 23.1.4). This test, in practical use, is a pass/fail test.

23.1.3 The results of the statistical analysis for repeatability and reproducibility of the individual systems in the interlaboratory study, determined in accordance with Practice E 691 (although the number of laboratories is lower than recommended by Practice E 691), are shown in Table 1. This is the analysis involving actual numerical results. Results of over 2 in. were not reported by the laboratories. Therefore, any result greater than 2 in. was considered to be 2 in., because testing was discontinued at this point, the maximum char length usually permitted by users. The precision calculated by assuming that the maximum char length measurement is 2.0 in. does not address the precision of the measurement over the entire possible range, but includes all values up to the point of failure, which are the measurements of concern. Figs. 10 and 11

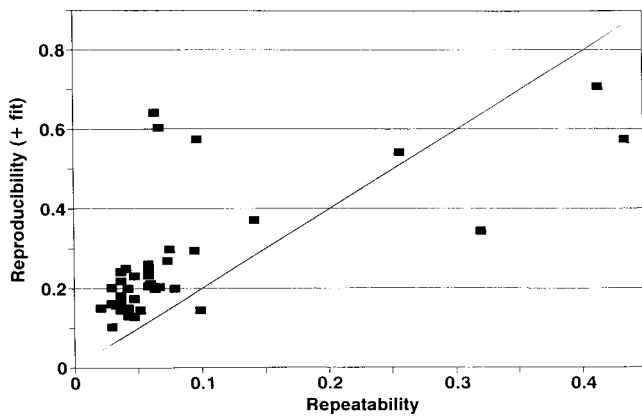
**TABLE 1 Interlaboratory Study for ASTM E 1353 (Results in in.)**

Class of Test	Material	Average	STD Repeat	STD Repro	<i>r</i>	<i>R</i>
Fabric Class Urethane Foam	Sample 1	0.693	0.320	0.343	0.90	0.96
	Sample 2	1.300	0.063	0.642	0.18	1.80
	Sample 3	0.633	0.047	0.128	0.13	0.36
	Sample 4	0.687	0.099	0.144	0.28	0.40
	Sample 5	1.353	0.414	0.708	1.16	1.98
	Sample 6	1.107	0.097	0.575	0.27	1.61
	Sample 7	1.013	0.141	0.372	0.40	1.04
	Sample 8	0.940	0.067	0.603	0.19	1.69
Barrier 1 in. PE/FR Cotton	Sample 1	0.492	0.033	0.157	0.09	0.44
	Sample 2	0.792	0.435	0.575	1.22	1.61
	Sample 3	0.508	0.075	0.297	0.21	0.83
	Sample 4	0.483	0.058	0.205	0.16	0.57
	Sample 5	0.542	0.058	0.260	0.16	0.73
	Sample 6	0.525	0.058	0.232	0.16	0.65
	Sample 7	0.517	0.058	0.249	0.16	0.70
	Sample 8	0.492	0.041	0.249	0.11	0.70
Barrier 1 in. PE/Foam	Sample 1	0.493	0.052	0.145	0.14	0.40
	Sample 2	0.753	0.256	0.541	0.72	1.52
	Sample 3	0.520	0.073	0.269	0.20	0.75
	Sample 4	0.647	0.094	0.294	0.26	0.82
	Sample 5	0.580	0.079	0.200	0.22	0.56
	Sample 6	0.700	0.060	0.211	0.17	0.59
	Sample 7	0.607	0.042	0.199	0.12	0.56
	Sample 8	0.573	0.037	0.163	0.10	0.46
Decking Test FR Cotton	Sample 1	0.347	0.021	0.151	0.06	0.42
	Sample 2	0.387	0.047	0.231	0.13	0.65
	Sample 3	0.360	0.030	0.202	0.08	0.57
	Sample 4	0.407	0.037	0.242	0.10	0.68
	Sample 5	0.353	0.030	0.161	0.08	0.45
	Sample 6	0.407	0.042	0.199	0.12	0.56
	Sample 7	0.407	0.063	0.200	0.18	0.56
	Sample 8	0.387	0.042	0.131	0.12	0.37
Decking Test Foam	Sample 1	0.333	0.037	0.148	0.10	0.42
	Sample 2	0.380	0.067	0.203	0.19	0.57
	Sample 3	0.400	0.037	0.180	0.10	0.51
	Sample 4	0.387	0.037	0.218	0.10	0.61
	Sample 5	0.333	0.030	0.103	0.08	0.29
	Sample 6	0.400	0.047	0.174	0.13	0.49
	Sample 7	0.400	0.037	0.145	0.10	0.40
	Sample 8	0.380	0.042	0.150	0.12	0.42

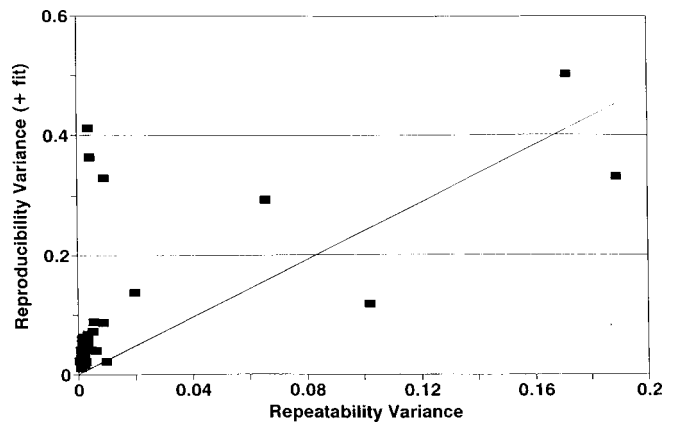


**TABLE 2 Interlaboratory Study for ASTM E 1353 (Results as Pass/Fail)**

Class of Test	Material	Average	STD Repeat	STD Repro	<i>r</i>	<i>R</i>
Fabric Class Urethane Foam	Sample 1	0.93	0.14	0.15	0.40	0.42
	Sample 2	0.60	0.28	0.55	0.79	1.53
	Sample 3	1.00	0.00	0.00	0.00	0.00
	Sample 4	1.00	0.00	0.00	0.00	0.00
	Sample 5	0.47	0.29	0.45	0.81	1.25
	Sample 6	0.80	0.23	0.45	0.65	1.25
	Sample 7	1.00	0.00	0.00	0.00	0.00
	Sample 8	0.80	0.23	0.45	0.65	1.25
Barrier 1 in. PE/FR Cotton	Sample 1	1.00	0.00	0.00	0.00	0.00
	Sample 2	0.92	0.16	0.17	0.45	0.47
	Sample 3	1.00	0.00	0.00	0.00	0.00
	Sample 4	1.00	0.00	0.00	0.00	0.00
	Sample 5	1.00	0.00	0.00	0.00	0.00
	Sample 6	1.00	0.00	0.00	0.00	0.00
	Sample 7	1.00	0.00	0.00	0.00	0.00
	Sample 8	1.00	0.00	0.00	0.00	0.00
Barrier 1 in. PE/Foam	Sample 1	1.00	0.00	0.00	0.00	0.00
	Sample 2	0.87	0.20	0.30	0.55	0.83
	Sample 3	1.00	0.00	0.00	0.00	0.00
	Sample 4	1.00	0.00	0.00	0.00	0.00
	Sample 5	1.00	0.00	0.00	0.00	0.00
	Sample 6	1.00	0.00	0.00	0.00	0.00
	Sample 7	1.00	0.00	0.00	0.00	0.00
	Sample 8	1.00	0.00	0.00	0.00	0.00
Decking Test FR Cotton	Sample 1	1.00	0.00	0.00	0.00	0.00
	Sample 2	1.00	0.00	0.00	0.00	0.00
	Sample 3	1.00	0.00	0.00	0.00	0.00
	Sample 4	1.00	0.00	0.00	0.00	0.00
	Sample 5	1.00	0.00	0.00	0.00	0.00
	Sample 6	1.00	0.00	0.00	0.00	0.00
	Sample 7	1.00	0.00	0.00	0.00	0.00
	Sample 8	1.00	0.00	0.00	0.00	0.00
Decking Test Foam	Sample 1	1.00	0.00	0.00	0.00	0.00
	Sample 2	1.00	0.00	0.00	0.00	0.00
	Sample 3	1.00	0.00	0.00	0.00	0.00
	Sample 4	1.00	0.00	0.00	0.00	0.00
	Sample 5	1.00	0.00	0.00	0.00	0.00
	Sample 6	1.00	0.00	0.00	0.00	0.00
	Sample 7	1.00	0.00	0.00	0.00	0.00
	Sample 8	1.00	0.00	0.00	0.00	0.00



**FIG. 10 Statistics on ASTM E 1353 (Data)—Repeatability vs Reproducibility (in.)**



**FIG. 11 Variance for ASTM E 1353 (Data)—Repeatability vs Reproducibility (in.)**

present the plot of reproducibility vs. repeatability and reproducibility variance vs. repeatability variance, for this analysis, respectively, as part of the information derived from Practice E 691. The abbreviations used are: STD Repeat: standard deviation of the repeatability; STD Repro: standard deviation of the reproducibility; *r*: system repeatability; and *R*: system reproducibility.

23.1.4 The results of the statistical analysis for repeatability and reproducibility of the individual systems, in the interlaboratory study, with the data analyzed as if they produce pass/fail results (fail was taken to be a value of over 2 in. for the barrier tests, of over 1.8 in. for the fabric class urethane foam test and of 1.5 in. for the decking tests) are shown in Table 2. Test results greater than the failure criterion were assigned a “Fail”

value of 0 and test results less than it were assigned a “Pass” value of 1. This analysis was conducted assuming that there can be two possible outcomes: Pass or Fail. Figs. 12 and 13 present the plot of reproducibility vs. repeatability and reproducibility variance vs. repeatability variance, for this analysis, respectively. Abbreviations are as in Table 1.<sup>5</sup>

23.1.5 Table 3 contains the overall repeatability and reproducibility of the test, analyzed both ways. The precision of the pass/fail data is significantly better than that of the numerical data. The abbreviations used are as follows: Avg: average; *r*: overall repeatability; *R*: overall reproducibility; Coeff STD fit: multiplicative coefficient of the linear regression analysis of reproducibility vs. repeatability; Coeff Variance fit: multiplicative coefficient of the linear regression analysis of reproducibility variance vs. repeatability variance; RSQ STD fit: linear least squares correlation coefficient of the fit between reproducibility and repeatability; RSQ Variance fit: linear least

<sup>5</sup> For additional information, see Ohlemiller, T.J., Villa, K.M., Braun, E., Eberhardt, K.R., Harris, R.H., Lawson, J.R., and Gann, R.G., “Test Methods for Quantifying the Propensity of Cigarettes to Ignite Soft Furnishings,” *NIST Special Publication 851*, National Institute of Standards Technology, Gaithersburg, MD, 1993.

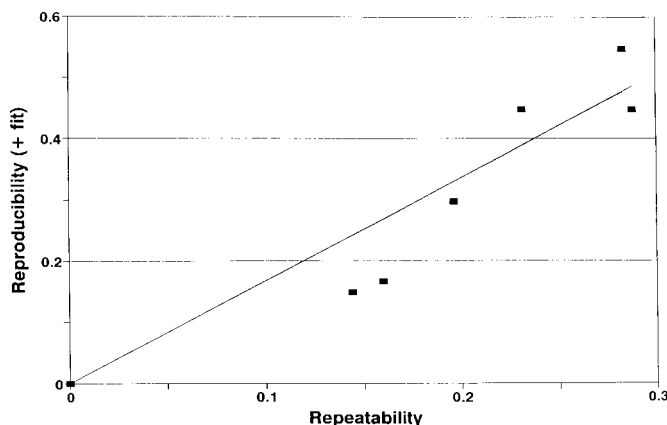


FIG. 12 Statistics on ASTM E 1353 (Pass)—Repeatability vs Reproducibility: P/F

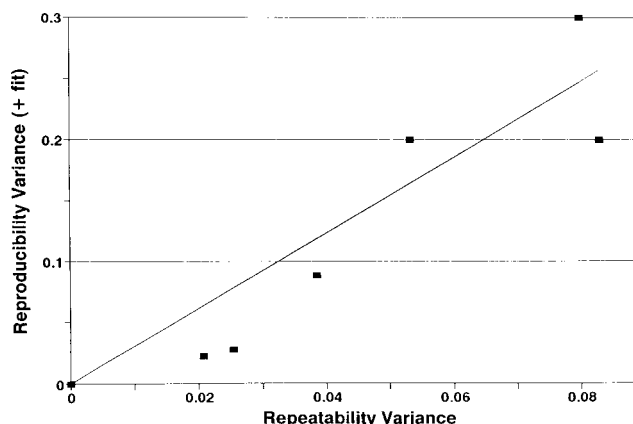


FIG. 13 Variance for ASTM E 1353 (Pass)—Repeatability vs Reproducibility: P/F

TABLE 3 Repeatability and Reproducibility of Test Method

	Numerical Data	Pass/Fail
Avg	0.58	0.96
<i>r</i>	0.24	0.11
<i>R</i>	0.75	0.18
Coeff STD fit	1.99	1.68
Coeff Variance fit	2.39	3.09
RSQ STD fit	-0.22	0.96
RSQ Variance fit	0.17	0.93

squares correlation coefficient of the fit between reproducibility variance and repeatability variance. The lack of fit (and the negative values of RSQ indicate simply that *r* and *R* are not correlated, which is not required for adequate precision.

23.2 *Bias*—The true value of cigarette ignition resistance of upholstered furniture components can only be defined in terms of a test method. Within this limitation, these test methods have no known bias and is generally accepted as a referee method.

## 24. Keywords

24.1 cigarette; component; furniture; ignition; resistance; upholstered

## APPENDIX

### (Nonmandatory Information)

#### X1. COMMENTARY

X1.1 *Introduction*—These test methods were developed by the Upholstered Furniture Action Council (UFAC), with the assistance of the National Institute of Standards and Technology and the Consumer Product Safety Commission. The goal of the effort was to devise a program that could be performed voluntarily by the upholstery industry itself; at the same time it had to compare with other much more complicated and costly protocols proposed concurrently. The resulting program now has been in place in the industry for ten years. Injury and loss

of life statistics have declined sharply during that period, attesting to the effectiveness of this program.

#### X1.2 *Nature of Test*

X1.2.1 Upholstered furniture is made by combining a number of necessary components: cover fabric, filling and padding, and decking substrates. Many pieces also include welt cords and interior fabric. The UFAC system has added to these basics the concept of a barrier between cellulosic cover fabric and

polyurethane padding material. In any ignition situation, all these materials tend to interact with each other in unpredictable ways. Therefore, it was clear early on to those developing the test that testing should not be for components singly, but must be in a simulation of the composite mode. Cover fabrics and urethane foam were standardized so that the other components could be tested in the composite mode, against these uniform reference materials.

X1.2.2 Duplicating actual furniture construction in the mock-ups is impractical, because of the myriad combinations of materials used by the industry. In developing a classification

system by which the comparatively smolder prone cover fabrics could be identified, UFAC was able to require that vulnerable cover fabrics be separated from polyurethane filling by a suitable barrier. Further, certain interior fabrics were found to encourage smoldering tendencies. A test was devised to identify and eliminate such materials. Welt cord proved to be critical, and it was necessary for UFAC to invent a heat-sink mechanism to prevent welt-cord smoldering or “wicking of the combustion,” a major source of furniture ignitions.

*ASTM International takes no position respecting the validity of any patent rights asserted in connection with any item mentioned in this standard. Users of this standard are expressly advised that determination of the validity of any such patent rights, and the risk of infringement of such rights, are entirely their own responsibility.*

*This standard is subject to revision at any time by the responsible technical committee and must be reviewed every five years and if not revised, either reapproved or withdrawn. Your comments are invited either for revision of this standard or for additional standards and should be addressed to ASTM International Headquarters. Your comments will receive careful consideration at a meeting of the responsible technical committee, which you may attend. If you feel that your comments have not received a fair hearing you should make your views known to the ASTM Committee on Standards, at the address shown below.*

*This standard is copyrighted by ASTM International, 100 Barr Harbor Drive, PO Box C700, West Conshohocken, PA 19428-2959, United States. Individual reprints (single or multiple copies) of this standard may be obtained by contacting ASTM at the above address or at 610-832-9585 (phone), 610-832-9555 (fax), or [service@astm.org](mailto:service@astm.org) (e-mail); or through the ASTM website ([www.astm.org](http://www.astm.org)).*