



# Standard Test Method for Heat and Visible Smoke Release Rates for Materials and Products Using an Oxygen Consumption Calorimeter<sup>1</sup>

This standard is issued under the fixed designation E 1354; the number immediately following the designation indicates the year of original adoption or, in the case of revision, the year of last revision. A number in parentheses indicates the year of last reapproval. A superscript epsilon ( $\epsilon$ ) indicates an editorial change since the last revision or reapproval.

## 1. Scope

1.1 This fire-test-response standard provides for measuring the response of materials exposed to controlled levels of radiant heating with or without an external ignitor.

1.2 This test method is used to determine the ignitability, heat release rates, mass loss rates, effective heat of combustion, and visible smoke development of materials and products.

1.3 The rate of heat release is determined by measurement of the oxygen consumption as determined by the oxygen concentration and the flow rate in the exhaust product stream. The effective heat of combustion is determined from a concomitant measurement of specimen mass loss rate, in combination with the heat release rate. Smoke development is measured by obscuration of light by the combustion product stream.

1.4 Specimens shall be exposed to heating fluxes in the range of 0 to 100 kW/m<sup>2</sup>. External ignition, when used, shall be by electric spark. The value of the heating flux and the use of external ignition are to be as specified in the relevant material or performance standard (see X1.2). The normal specimen testing orientation is horizontal, independent of whether the end-use application involves a horizontal or a vertical orientation. The apparatus also contains provisions for vertical orientation testing; this is used for exploratory or diagnostic studies only.

1.5 Ignitability is determined as a measurement of time from initial exposure to time of sustained flaming.

1.6 This test method has been developed for use for material and product evaluations, mathematical modeling, design purposes, or development and research. Examples of material specimens include portions of an end-use product or the various components used in the end-use product.

1.7 The values stated in SI units are to be regarded as the standard.

1.8 *This standard is used to measure and describe the response of materials, products, or assemblies to heat and flame under controlled conditions, but does not by itself incorporate all factors required for fire hazard or fire risk*

*assessment of the materials, products, or assemblies under actual fire conditions.*

1.9 *This standard does not purport to address all of the safety concerns, if any, associated with its use. It is the responsibility of the user of this standard to establish appropriate safety and health practices and determine the applicability of regulatory limitations prior to use.* For specific hazard statements, see Section 7.

## 2. Referenced Documents

### 2.1 ASTM Standards:

D 3286 Test Method for Gross Calorific Value of Coal and Coke by the Isooperibol Bomb Calorimeter<sup>2</sup>

E 176 Terminology of Fire Standards<sup>3</sup>

E 177 Practice for Use of the Terms Precision and Bias in ASTM Test Methods<sup>4</sup>

E 662 Test Method for Specific Optical Density of Smoke Generated by Solid Materials<sup>3</sup>

E 691 Practice for Conducting an Interlaboratory Study to Determine the Precision of a Test Method<sup>4</sup>

E 906 Test Method for Heat and Visible Smoke Release Rates for Materials and Products<sup>3</sup>

### 2.2 ISO Standards:

ISO 5657-1986(E) Fire Tests—reaction to fire—ignitability of building materials<sup>5</sup>

ISO 5725 Precision of test methods—determination of repeatability and reproducibility for a standard test method by inter-laboratory tests<sup>5</sup>

## 3. Terminology

3.1 *Definitions*—For definitions of terms used in this test method, refer to Terminology E 176.

### 3.2 *Definitions of Terms Specific to This Standard:*

3.2.1 *effective heat of combustion, n*—the measured heat release divided by the mass loss for a specified time period.

3.2.2 *heating flux, n*—the incident flux imposed externally from the heater on the specimen at the initiation of the test.

3.2.2.1 *Discussion*—The specimen, once ignited, is also

<sup>1</sup> This test method is under the jurisdiction of ASTM Committee E05 on Fire Standards and is the direct responsibility of Subcommittee E05.21 on Smoke and Combustion Products.

Current edition approved August 10, 2002. Published September 2002. Originally published as E 1354 – 90. Last previous edition E 1354 – 02.

<sup>2</sup> *Annual Book of ASTM Standards*, Vol 05.06.

<sup>3</sup> *Annual Book of ASTM Standards*, Vol 04.07.

<sup>4</sup> *Annual Book of ASTM Standards*, Vol 14.02.

<sup>5</sup> Available from American National Standards Institute (ANSI), 25 W. 43rd St., 4th Floor, New York, NY 10036.

heated by its own flame.

3.2.3 *heat release rate, n*—the heat evolved from the specimen, per unit of time.

3.2.4 *ignitability, n*—the propensity to ignition, as measured by the time to sustained flaming, in seconds, at a specified heating flux.

3.2.5 *net heat of combustion, n*—the oxygen bomb (see Test Method D 3286) value for the heat of combustion, corrected for gaseous state of product water.

3.2.6 *orientation, n*—the plane in which the exposed face of the specimen is located during testing, either vertical or horizontal facing up.

3.2.7 *oxygen consumption principle, n*—the expression of the relationship between the mass of oxygen consumed during combustion and the heat released.

3.2.8 *smoke obscuration, n*—reduction of light transmission by smoke, as measured by light attenuation.

3.2.9 *sustained flaming, n*—existence of flame on or over most of the specimen surface for periods of at least 4 s.

3.2.9.1 *Discussion*—Flaming of less than 4 s duration is identified as flashing or transitory flaming.

3.3 *Symbols:*

$A_s$	= nominal specimen exposed surface area, 0.01 m <sup>2</sup> .
$C$	= calibration constant for oxygen consumption analysis, m <sup>1/2</sup> – kg <sup>1/2</sup> – K <sup>1/2</sup> .
$\Delta h_c$	= net heat of combustion, kJ/kg.
$\Delta h_{c,eff}$	= effective heat of combustion, kJ/kg.
$I$	= actual beam intensity.
$I_o$	= beam intensity with no smoke.
$k$	= smoke extinction coefficient, m <sup>-1</sup> .
$L$	= extinction beam path length, m.
$m$	= specimen mass, kg.
$m_f$	= final specimen mass, kg.
$m_i$	= initial specimen mass, kg.
$\dot{m}$	= specimen mass loss rate, kg/s.
$\Delta P$	= orifice meter pressure differential, Pa.
$q''_{tot}$	= total heat released, kJ/m <sup>2</sup> (Note that kJ ≡ kW·s).
$\dot{q}$	= heat release rate, kW.
$q''$	= heat release rate per unit area, kW/m <sup>2</sup> .
$q''_{max}$	= maximum heat release rate per unit area (kW/m <sup>2</sup> ).
$q''_{180}$	= average heat release rate, per unit area, over the time period starting at $t_{ig}$ and ending 180 s later (kW/m <sup>2</sup> ).
$r$	= repeatability (the units are the same as for the variable being characterized).
$R$	= reproducibility (the units are the same as for the variable being characterized).
$r_o$	= stoichiometric oxygen/fuel mass ratio (–).
$s_r$	= sample-based standard deviation estimate for repeatability (same units as $r$ ).
$s_R$	= sample-based standard deviation estimate for reproducibility (same units as $R$ ).
$t$	= time, s.
$t_d$	= oxygen analyzer delay time, s.
$t_{ig}$	= time to sustained flaming (s).
$\rho$	= density (kg/m <sup>3</sup> ).
$\Delta t$	= sampling time interval, s.

$T_e$	= absolute temperature of gas at the orifice meter, K.
$\dot{V}$	= volume exhaust flow rate, measured at the location of the laser photometer, m <sup>3</sup> /s.
$X_{O_2}$	= oxygen analyzer reading, mole fraction O <sub>2</sub> (–).
$X_{O_2,0}$	= initial value of oxygen analyzer reading (–).
$X_{O_2,1}$	= oxygen analyzer reading, before delay time correction (–).
$\sigma_f$	= specific extinction area, for smoke, m <sup>2</sup> /kg.
$\sigma_r$	= repeatability standard deviation (same units as $r$ ).
$\sigma_R$	= reproducibility standard deviation (same units as $R$ ).

#### 4. Summary of Test Method

4.1 This test method is based on the observation (1)<sup>6</sup> that, generally, the net heat of combustion is directly related to the amount of oxygen required for combustion. The relationship is that approximately 13.1 × 10<sup>3</sup> kJ of heat are released per 1 kg of oxygen consumed. Specimens in the test are burned in ambient air conditions, while being subjected to a predetermined external heat flux, which can be set from 0 to 100 kW/m<sup>2</sup>. Burning may be either with or without a spark ignition. The primary measurements are oxygen concentrations and exhaust gas flow rate. Additional measurements include the mass-loss rate of the specimen, the time to sustained flaming and smoke obscuration, or as required in the relevant material or performance standard.

#### 5. Significance and Use

5.1 This test method is used primarily to determine the heat evolved in, or contributed to, a fire involving products of the test material. Also included is a determination of the effective heat of combustion, mass loss rate, the time to sustained flaming, and smoke production. These properties are determined on small size specimens that are representative of those in the intended end use.

5.2 This test method is applicable to various categories of products and is not limited to representing a single fire scenario. Additional guidance for testing is given in X1.2.3 and X1.11.

5.3 This test method is not applicable to end-use products that do not have planar, or nearly planar, external surfaces.

#### 6. Apparatus

##### 6.1 General:

6.1.1 Where explicitly stated in the following description, dimensions are mandatory and should be followed within nominal tolerances of ±1 mm, unless otherwise specified. Such dimensions are followed by an asterisk in Figs. 1-12.

6.1.2 The test apparatus<sup>7</sup> shall consist essentially of the following components: a conical radiant electric heater, capable of horizontal or vertical orientation; specimen holders, different for the two orientations; an exhaust gas system with oxygen monitoring and flow measuring instrumentation; an

<sup>6</sup> The boldface numbers in parentheses refer to the list of references at the end of this test method.

<sup>7</sup> A list of suppliers of this apparatus is available from ASTM Headquarters.

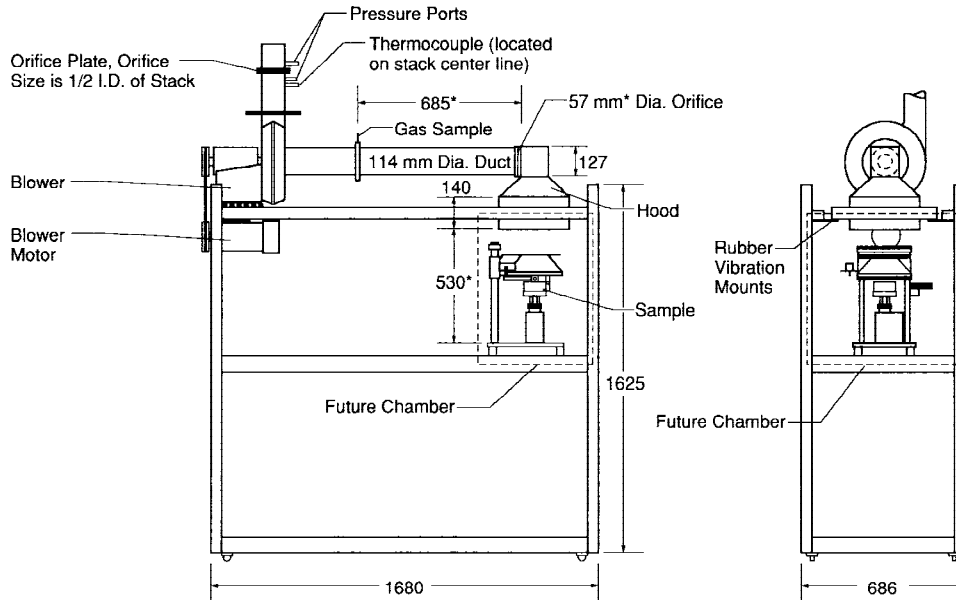

NOTE 1—All dimensions are in millimetres.  
NOTE 2—\* Indicates a critical dimension.

FIG. 1 Overall View of Apparatus

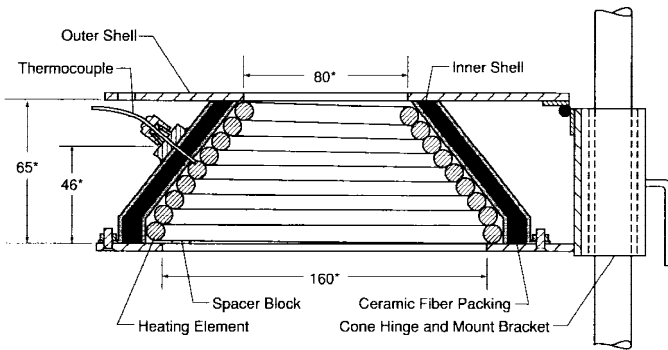

NOTE 1—All dimensions are in millimetres.  
NOTE 2—\* Indicates a critical dimension.

FIG. 2 Cross-Section View Through the Heater

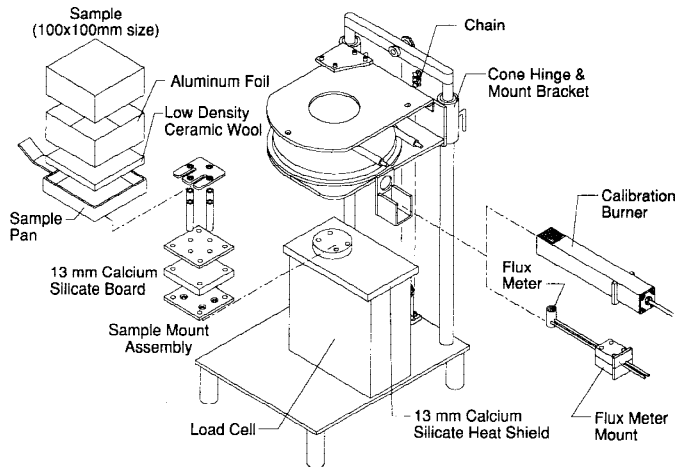

FIG. 3 Exploded View, Horizontal Orientation

electric ignition spark plug; a data collection and analysis system; and a load cell for measuring specimen mass loss. A general view of the apparatus is shown in Fig. 1; a cross section through the heater in Fig. 2; and exploded views of horizontal and vertical orientations in Fig. 3 and Fig. 4.

6.1.3 Additional details describing features and operation of the test apparatus are given in Ref (2).

6.2 Conical Heater:

6.2.1 The active element of the heater shall consist of an electrical heater rod, rated at 5000 W at 240 V, tightly wound into the shape of a truncated cone (Fig. 2 and Fig. 4). The heater shall be encased on the outside with a double-wall stainless steel cone, packed with a refractory fiber material of approximately 100 kg/m<sup>3</sup> density.

6.2.2 The heater shall be hinged so it can be swung into either a horizontal or a vertical orientation. The heater shall be capable of producing irradiances on the surface of the specimen of up to 100 kW/m<sup>2</sup>. The irradiance shall be uniform within the central 50 by 50-mm area of the specimen to within

± 2 % in the horizontal orientation and to within ± 10 % in the vertical orientation. As the geometry of the heater is critical, the dimensions on Fig. 2 are mandatory.

6.2.3 The irradiance from the heater shall be capable of being held at a preset level by means of a temperature controller and three type K stainless steel sheathed thermocouples, symmetrically disposed and in contact with, but not welded to, the heater element (see Fig. 2). The thermocouples shall be of equal length and wired in parallel to the temperature controller. The standard thermocouples are sheathed, 1.5 and 1.6 mm outside diameter, with an unexposed hot junction. Alternatively, either 3 mm outside diameter sheathed thermocouples with an exposed hot junction or 1 mm outside diameter sheathed thermocouples with unexposed hot junction can be used.

6.3 Temperature Controller:

6.3.1 The temperature controller for the heater shall be

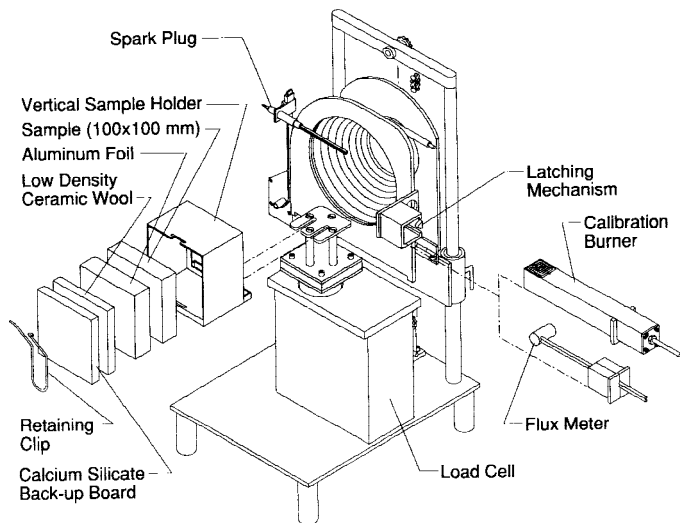

FIG. 4 Exploded View, Vertical Orientation

capable of holding the element temperature steady to within  $\pm 2^\circ\text{C}$ . A suitable system is a 3-term controller (proportional, integral, and derivative) and a thyristor unit capable of switching currents up to 25 A at 240 V.

6.3.2 The controller shall have a temperature input range of 0 to  $1000^\circ\text{C}$ ; a set scale capable of being read to  $2^\circ\text{C}$  or better; and automatic cold junction compensation. The controller shall be equipped with a safety feature such that in the event of an open circuit in the thermocouple line, it will cause the temperature to fall to near the bottom of its range.

6.3.3 The thyristor unit shall be of the zero crossing and not of the phase angle type.

6.3.4 The heater temperature shall be monitored by a meter capable of being read to  $\pm 2^\circ\text{C}$ , or better. It shall be permitted to be incorporated into the temperature controller.

6.4 Exhaust System:

6.4.1 The exhaust-gas system shall consist of a high temperature centrifugal exhaust fan, a hood, intake and exhaust ducts for the fan, and an orifice plate flowmeter (Fig. 5). The exhaust system shall be capable of developing flows from 0.012 to  $0.035\text{ m}^3/\text{s}$ .

6.4.2 A restrictive orifice (57 mm inside diameter) shall be located between the hood and the duct to promote mixing.

6.4.3 A ring sampler shall be located in the fan intake duct for gas sampling, 685 mm from the hood (Fig. 1). The ring sampler shall contain twelve holes to average the stream composition with the holes facing away from the flow to avoid soot clogging.

6.4.4 The temperature of the gas stream shall be measured using a 1.0 to 1.6 mm outside diameter sheathed-junction thermocouple or a 3 mm outside diameter exposed junction thermocouple positioned in the exhaust stack on the centerline and 100 mm upstream from the measuring orifice plate.

6.4.5 The flow rate shall be determined by measuring the differential pressure across a sharp-edged orifice (57 mm inside diameter) in the exhaust stack, at least 350 mm downstream from the fan when the latter is located as shown in Fig. 5.

6.4.6 In other details, the geometry of the exhaust system is not critical. Where necessary, small deviations from the recommended dimensions given in Fig. 5 shall be permitted to be

made. The inner diameter of the duct and the orifice plates is not a critical dimension. Also the fan does not need to be at the exact location as indicated on Fig. 5, but shall be permitted to be further downstream, allowing for a more common type of fan to be used. In this case, sufficient undisturbed inflow distances to the gas sampling probe and the measuring orifice shall be provided for the flow to be uniformly mixed.

6.5 Load Cell—The general arrangement of the specimen holders on the load cell is indicated in Fig. 3 and Fig. 4. The load cell shall have an accuracy of 0.1 g, and shall have a total weighing range of at least 3.5 kg of which at least 500 g shall be available for direct monitoring during any single test.

6.6 Specimen Mounting:

6.6.1 The horizontal specimen holder is shown in Fig. 6.

6.6.2 The bottom of the horizontal specimen holder shall be lined with a layer of low density (nominal density  $65\text{ kg/m}^3$ ) refractory fiber blanket with a thickness of at least 13 mm. The distance between the bottom surface of the cone heater and the top of the specimen shall be adjusted to be 25 mm. For mechanisms constructed according to the drawing in Fig. 2, this is accomplished by using the sliding cone height adjustment.

6.6.3 The vertical specimen holder is shown in Fig. 7 and includes a small drip tray to contain a limited amount of molten material. A specimen shall be installed in the vertical specimen holder by backing it with a layer of refractory fiber blanket (nominal density  $65\text{ kg/m}^3$ ), the thickness of which depends on specimen thickness, but shall be at least 13 mm thick. A layer of rigid, ceramic fiber millboard shall be placed behind the fiber blanket layer. The millboard thickness shall be such that the entire assembly is rigidly bound together once the retaining spring clip is inserted behind the millboard. In the vertical orientation, the cone heater height is set so the center lines up with the specimen center.

6.6.4 The testing technique to be used when testing intumescent specimens in the horizontal orientation shall be documented in the test report. Options include the retainer frame (Fig. 12) and wire grid (Fig. 8). The edge frame is used to reduce unrepresentative edge burning of specimens while the wire grid is used for retaining specimens prone to delamination. The wire grid shown in Fig. 8 is also suitable for the vertical orientation.

6.7 Radiation Shield—The cone heater shall be provided with a removable radiation shield to protect the specimen from the heat flux prior to the start of a test. The shield shall be made of noncombustible material with a total thickness not to exceed 12 mm. The shield shall be one of the following:

- (a) water cooled and coated with a durable matte black finish of surface emissivity  $e = 0.95 \pm 0.05$  or
- (b) not water cooled with a reflective top surface to minimize radiation transfer.

The shield shall be equipped with a handle or other suitable means for quick insertion and removal. The cone heater base plate shall be equipped with the means for holding the shield in position and allowing its easy and quick removal.

6.8 Ignition Circuit—External ignition is accomplished by a spark plug powered from a 10-kV transformer. The spark plug shall have a gap of 3 mm. The transformer must be of a type



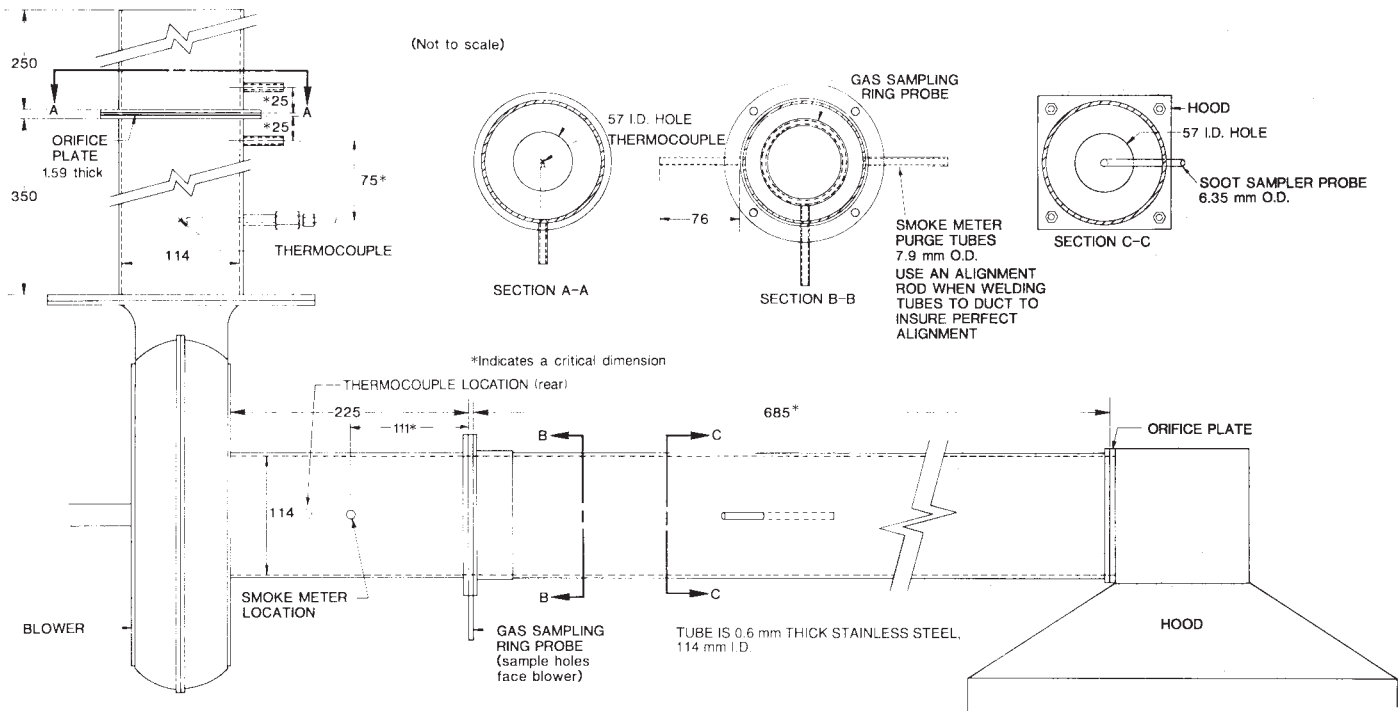

NOTE 1—All dimensions are in millimetres (not to scale).

FIG. 5 Exhaust System

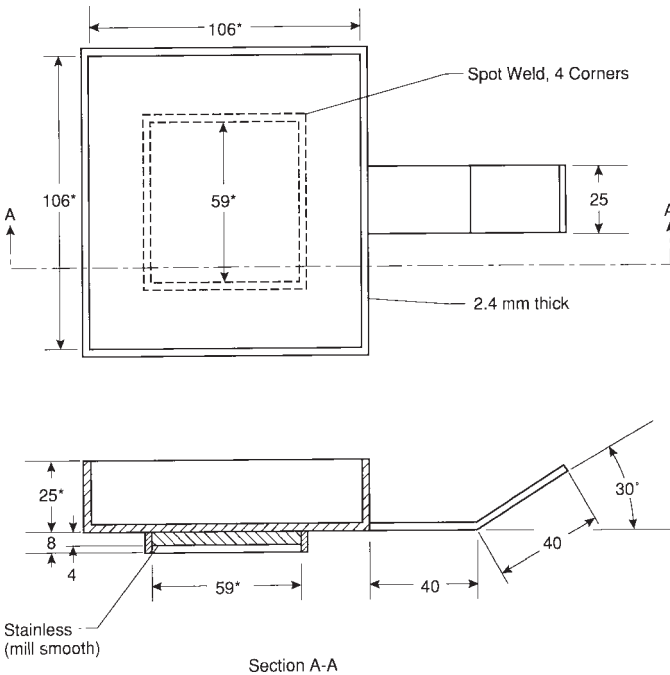

NOTE 1—All dimensions are in millimetres.

NOTE 2—\* Indicates a critical dimension.

FIG. 6 Horizontal Specimen Holder

specifically designed for spark-ignition use. The transformer shall have an isolated (ungrounded) secondary to minimize interference with the data-transmission lines. The electrode length and location of the spark plug shall be such that the spark gap is located 13 mm above the center of the specimen

in the horizontal orientation; in the vertical orientation the gap shall be located in the specimen face plane and 5 mm above the top of the holder. In either position the spark plug shall be removed when sustained flaming is achieved.

6.9 Ignition Timer—The timing device for measuring time to sustained flaming shall be capable of recording elapsed time to the nearest second and shall be accurate to within 1 s in 1 h.

6.10 Gas Sampling—Gas sampling arrangements are shown in Fig. 9. They shall incorporate a pump, a filter to prevent entry of soot, a cold trap to remove most of the moisture, a bypass system set to divert all flow except that required for the oxygen analyzer, a further moisture trap, and a trap for carbon dioxide (CO<sub>2</sub>) removal; the latter if CO<sub>2</sub> is not measured. When a CO<sub>2</sub> trap is used, the sample stream entering the oxygen analyzer must be fully dry; some designs of CO<sub>2</sub> traps require an additional moisture trap downstream of the CO<sub>2</sub> trap.

NOTE 1—If an optional CO<sub>2</sub> analyzer is used instead of removing CO<sub>2</sub> from the oxygen analyzer stream, the equations to calculate the rate of heat release will be different from those for the standard case (Section 12) and are, instead, given in Annex A1.

6.11 Oxygen Analyzer—The analyzer shall be of the paramagnetic type with a range from 0 to 25 % oxygen. The analyzer shall exhibit a linear response and drift of not more than ±50 ppm oxygen (root-mean-square value) over a period of ½ h. Since oxygen analyzers are sensitive to stream pressures, the stream pressure shall be regulated (upstream of the analyzer) to allow for flow fluctuations, and the readings from the analyzer compensated with an absolute pressure regulator to allow for atmospheric pressure variations. The analyzer and the absolute pressure regulator shall be located in

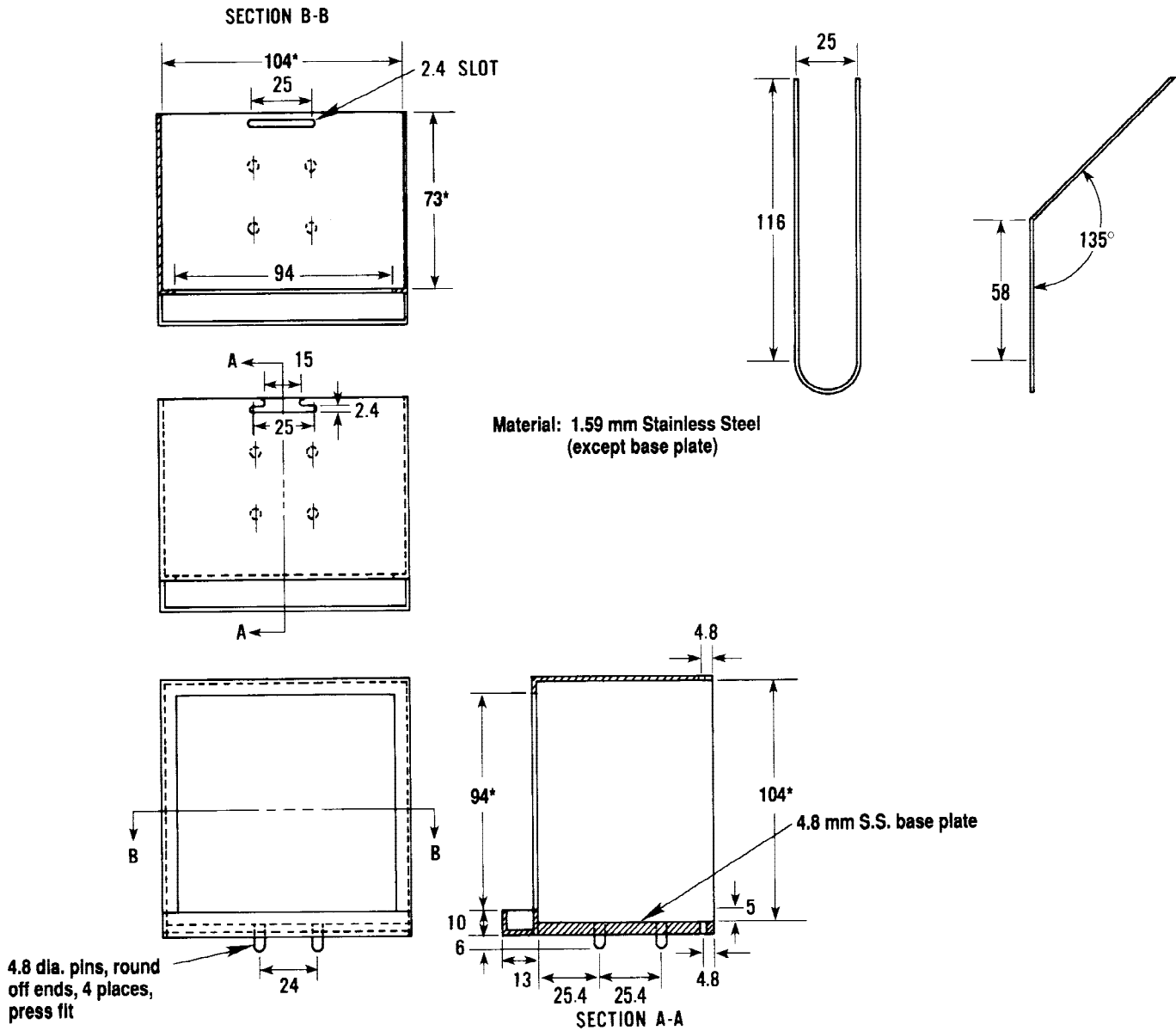

NOTE 1—All dimensions are in millimetres except where noted.  
NOTE 2—\* Indicates a critical dimension.

FIG. 7 Vertical Specimen Holder

a constant-temperature environment. The oxygen analyzer shall have a 10 to 90 % response time of less than 12 s.

6.12 *Smoke Obscuration Measuring System*—The smoke measuring system (Fig. 10) comprises a helium-neon laser, silicon photodiodes as main beam and reference detectors, and appropriate electronics to derive the extinction coefficient and to set the zero reading. The system is designed for split yoke mounting in two pieces, which are rigidly screwed together but resiliently attached to the exhaust duct by means of refractory gasketing, at the location shown in Fig. 5. The meter is located in place by means of two small-diameter tubes welded onto each side of the exhaust duct. These serve as part of the light baffling for the air purging and also serve to aid in the desposition on the tube walls of any smoke that enters despite the purge flow, so that it does not reach the optical elements.

6.13 *Heat Fluxmeter:*

6.13.1 The total heat fluxmeter shall be of the Gardon (foil) or Schmidt-Boelter (thermopile) type with a design range of about 100 kW/m<sup>2</sup>. The target receiving radiation, and possibly to a small extent convection, shall be flat, circular, approximately 12.5 mm in diameter, and coated with a durable matte-black finish. The target shall be water cooled. Radiation shall not pass through any window before reaching the target. The instrument shall be robust, simple to set up and use, and stable in calibration. The instrument shall have an accuracy of within ±3 % and a repeatability within 0.5 %.

6.13.2 The calibration of the heat fluxmeter shall be checked whenever a recalibration of the apparatus is carried out by comparison with an instrument (of the same type as the working heat fluxmeter and of similar range) held as a

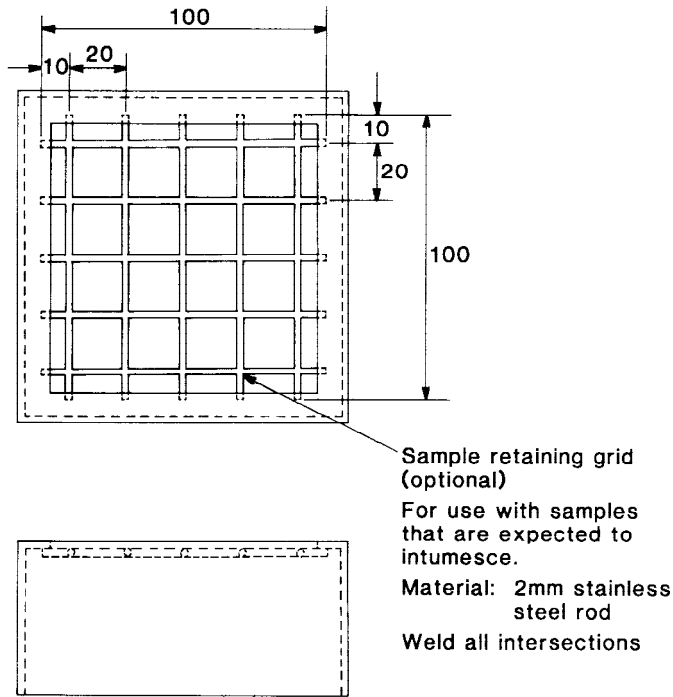

Material: Stainless steel, 1.9 mm thick

NOTE 1—All dimensions are in millimetres.

FIG. 8 Optional Wire Grid (For Horizontal or Vertical Orientation)

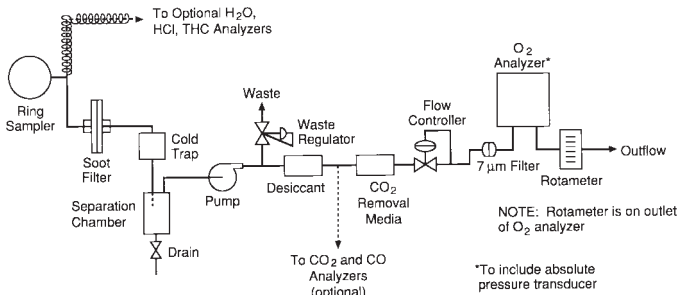

NOTE 1—Rotameter is on outlet of the oxygen (O<sub>2</sub>) analyzer.

FIG. 9 Gas Analyzer Instrumentation

reference standard and not used for any other purpose. The reference standard shall be fully calibrated at a standardizing laboratory at yearly intervals.

6.13.3 This meter shall be used to calibrate the heater temperature controller (Fig. 3 and Fig. 4). It shall be positioned at a location equivalent to the center of the specimen face in either orientation during this calibration.

6.14 *Calibration Burner*—To calibrate the rate of heat release apparatus, a burner is used (Fig. 3 and Fig. 4). The burner is constructed from a square-section brass tube with a square orifice covered with wire gauze through which the methane diffuses (Fig. 11). The tube is packed with ceramic fiber to improve uniformity of flow. The calibration burner is suitably connected to a metered supply of methane of at least 99.5 % purity.

6.15 *Optical Calibration Filters*—Glass neutral density filters, of at least two different values accurately calibrated at the

laser wavelength of 0.6328 µm, are required.

6.16 *Digital Data Collection*—The data collection system used must have facilities for the recording of the output from the oxygen analyzer, the orifice meter, the thermocouples, the load cell, and the smoke measuring system. The data collection system shall have an accuracy corresponding to at least 50 ppm oxygen for the oxygen channel, 0.5°C for the temperature measuring channels, and 0.01 % of full-scale instrument output for all other instrument channels. The system shall be capable of recording data for at least 1 h, at intervals not exceeding 5 s.

## 7. Hazards

7.1 The test procedures involve high temperatures and combustion processes. Therefore, hazards exist for burns, ignition of extraneous objects or clothing, and for inhalation of combustion products. The operator shall use protective gloves for insertion and removal of test specimens. Neither the cone heater nor the associated fixtures shall be touched while hot except with the use of protective gloves. The possibility of the violent ejection of molten hot material or sharp fragments from some kinds of specimens when irradiated cannot totally be discounted and eye protection shall be worn.

7.2 The exhaust system shall be checked for proper operation before testing and must discharge into a building exhaust system with adequate capacity. Provision shall be made for collecting and venting any combustion products that are not collected by the normal exhaust system of the apparatus.

## 8. Test Specimens

### 8.1 Size and Preparation:

8.1.1 Test specimens shall be 100 by 100 mm in area, up to 50-mm thick, and cut to be representative of the construction of the end-use product. For products of normal thickness greater than 50 mm, the requisite specimens shall be obtained by cutting away the unexposed face to reduce the thickness to 50 mm. For testing, wrap specimens in a single layer of aluminum foil, shiny side toward the specimen, covering the sides and bottom. Foil thickness shall be 0.025 to 0.04 mm.

8.1.2 Expose composite specimens in a manner typical of the end-use condition. Prepare them so the sides are covered with the outer layer(s) or otherwise protected.

8.1.3 Some composite and intumescent materials require special mounting and retaining techniques to retain them adequately within the specimen holder during combustion. Such mounting techniques include the use of an edge frame (Fig. 12) in the horizontal orientation, the use of a wire grid in either orientation, or other special mounting procedures suitable to the specimen being tested. Fig. 8 shows a wire grid suitable for several types of intumescent specimens. The exact mounting and retaining method used shall be specified in the test report. Additional specialized guidance to the operator is provided in Ref (2).

8.1.4 Assemblies shall be tested as specified in 8.1.2 or 8.1.3 as appropriate. However, where thin materials or composites are used in the fabrication of an assembly, the presence of an air gap or the nature of any underlying construction often significantly affects the ignition and burning characteristics of the exposed surface. The influence of the underlying layers

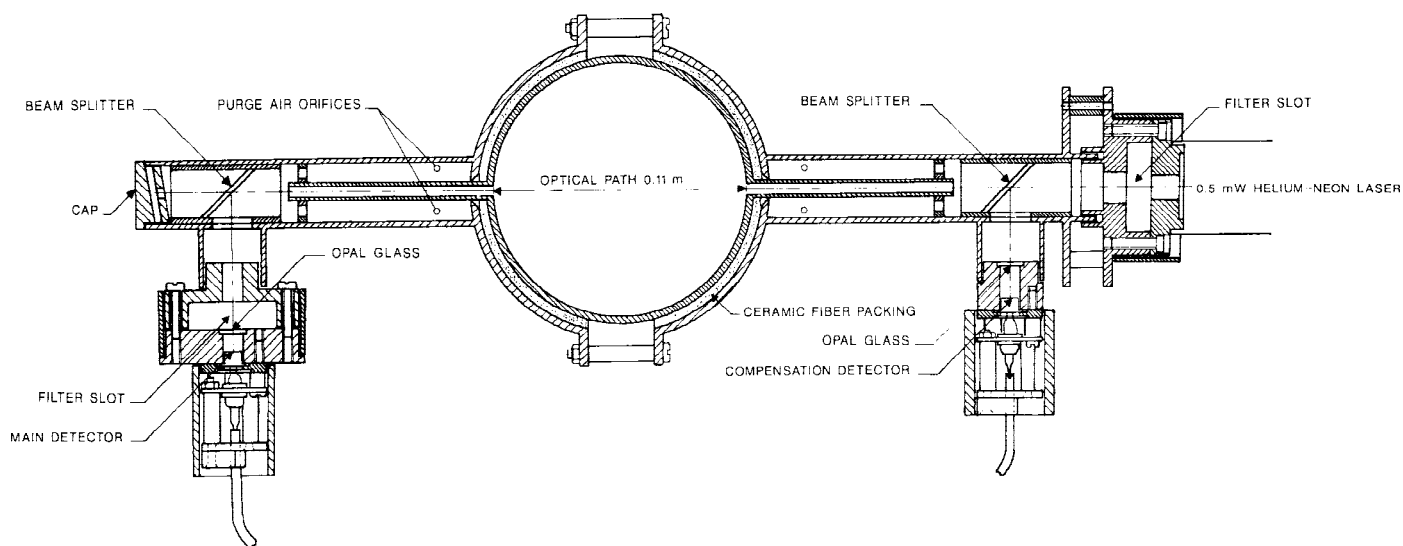

FIG. 10 Smoke Obscuration Measuring System

must be understood and care taken to ensure that the test result obtained on any assembly is relevant to its use in practice. When the product is a material or composite that is normally attached to a well defined substrate, it shall be tested in conjunction with that substrate, using the recommended fixing technique, for example, bonded with the appropriate adhesive or mechanically fixed.

8.1.5 Products that are thinner than 6 mm shall be tested with a substrate representative of end use conditions, such that the total specimen thickness is 6 mm or more. In the case of specimens of less than 6 mm in thickness and that are used with an air space adjacent to the unexposed face, the specimens shall be mounted so that there is an air space of at least 12 mm between its unexposed face and the refractory fibre blanket. This is achieved by the use of a metal spacer frame.

8.2 *Conditioning*—Specimens shall be conditioned to moisture equilibrium (constant weight) at an ambient temperature of  $23 \pm 3^\circ\text{C}$  and a relative humidity of  $50 \pm 5\%$ .

## 9. Test Environment

9.1 The apparatus shall be located in a draft-free environment in an atmosphere of relative humidity of between 20 and 80 % and a temperature between 15 and  $30^\circ\text{C}$ .

## 10. Calibration of Apparatus

10.1 *Heater Flux Calibration*—Set the temperature controller to the required flux by using the heat fluxmeter at the start of the test day, after changing to a new flux level, or when the cone-heater orientation is changed. Do not use a specimen holder when the heat fluxmeter is inserted into the calibration position. Operate the cone heater for at least 10 min and ensure that the controller is within its proportional band before beginning this calibration.

### 10.2 Oxygen Analyzer Calibration:

#### 10.2.1 Preliminary Calibrations:

10.2.1.1 The oxygen analyzer delay time must be determined. This is done by arranging for a methane flow rate equivalent to 5 kW to the calibration burner. The heater shall not be turned on for this calibration. Record the output of the

analyzer on a strip-chart recorder as the methane supply, turned on and ignited, reaches a steady value, and then returns to baseline after the supply is cut off. Record the temperature for the exhaust-orifice meter at the same time. Determine the turn-on delay as the time difference between the time when the temperature reading reaches 50 % of its ultimate deflection and the time when the oxygen reading reaches 50 % of its ultimate deflection. Determine the turn-off delay similarly at turn-off. Take the delay time as the average of the turn-on delay and turn-off delay. Use this value,  $t_d$ , subsequently to time-shift all the oxygen readings.

10.2.1.2 If the oxygen analyzer is equipped with an electric response-time adjustment, set it so that at turn-off there is just a trace of overshoot when switching rapidly between two different calibration gases.

10.2.1.3 The timing of the scans by the data collection system shall be calibrated with a timer accurate to within 1 s in 1 h. The data output shall show event times correct to 3 s.

10.2.2 *Operating Calibrations*—At the start of testing each day, the oxygen analyzer shall be zeroed and calibrated. For zeroing, the analyzer shall be fed with nitrogen gas with the same flow rate and pressure as for the sample gases. Calibration shall be similarly achieved using ambient air and adjusting for a response of 20.95 %. Analyzer flow rates shall be carefully monitored and set to be equal to the flow rate used when testing specimens. After each specimen has been tested, ensure that a response level of 20.95 % is obtained using ambient air.

### 10.3 Heat Release Rate Calibration:

10.3.1 The heat release calibration shall be performed at the start of testing each day. Methane (purity of at least 99.5 %) shall be introduced into the calibration burner at a flow rate corresponding to 5 kW based on the net heat of combustion of methane ( $50.0 \times 10^3\text{kJ/kg}$ ) using a precalibrated flowmeter. The flowmeter used shall be one of the following: a dry test meter, a wet test meter, or an electronic mass flow controller. If an electronic mass-flow controller is used, it shall be calibrated periodically against a dry test meter or a wet test meter. The test



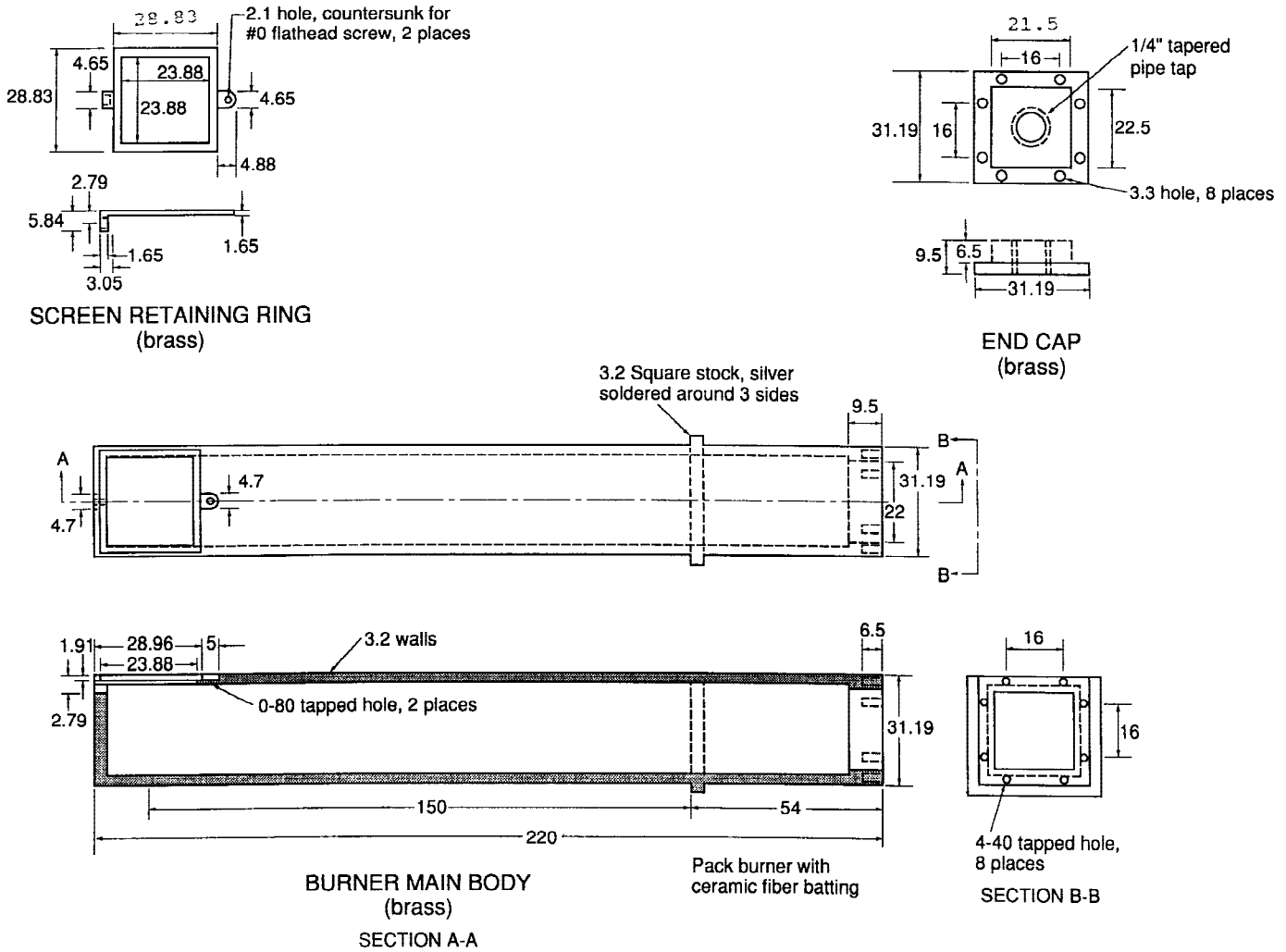

NOTE 1—All dimensions are in millimetres except where noted.

FIG. 11 Calibration Burner

meter shall be equipped with devices to measure the temperature and pressure of the flowing gas, so that appropriate corrections to the reading may be made. If a wet test meter is used, the readings shall also be corrected for the moisture content. The exhaust fan shall be set to the speed to be used for subsequent testing. The required calculations are given in Section 13.

NOTE 2—It shall be permitted for calibration to be performed with the cone heater operating or not, but calibration shall not be performed during heater warm up.

10.4 *Load Cell Calibration*—The load cell shall be calibrated with standard weights in the range of test specimen weight each day of testing or when the load cell mechanical zero needs to be adjusted. Adjust the load cell mechanical zero if necessary due to different specimen holder tare weights after changing orientation.

10.5 *Smoke Meter Calibration*—The smoke meter is initially calibrated to read correctly for two different value neutral density filters, and also at 100 % transmission. Once this calibration is set, only the zero value of extinction coefficient (100 % transmission) normally needs to be verified prior to each test.

## 11. Procedure

### 11.1 Preparation:

11.1.1 Check the CO<sub>2</sub> trap and the final moisture trap. Replace the sorbents if necessary. Drain any accumulated water in the cold trap separation chamber. Normal operating temperature of the cold trap shall be the lowest temperature at which trap freezing does not occur (approximately 0°C).

NOTE 3—If any of the traps or filters in the gas sampling line have been opened during the check, the gas sampling system shall be checked for leaks, for example, by introducing pure nitrogen, at the same flow rate and pressure as for the sample gases, from a nitrogen source connected as close as possible to the ring sampler. The oxygen analyzer must then read zero.

11.1.2 Turn on power to the cone heater and the exhaust blower. (Power to the oxygen analyzer, load cell, and pressure transducer is not to be turned off on a daily basis.)

11.1.3 Set an exhaust flow rate of  $0.024 \pm 0.002$  m<sup>3</sup>/s. (Under room temperature conditions this corresponds to approximately 30 g/s.)

11.1.4 Perform the required calibration procedures specified in Section 9. In the horizontal orientation, put an empty specimen holder (with refractory blanket) in place during

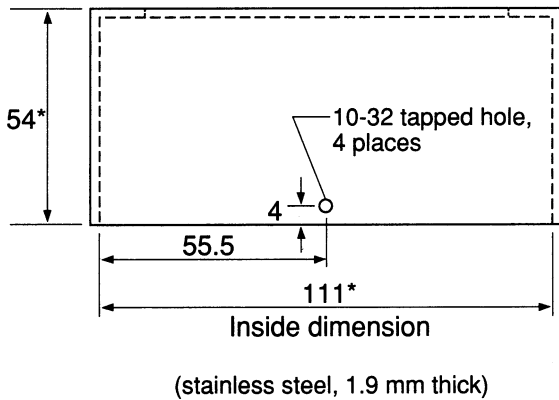
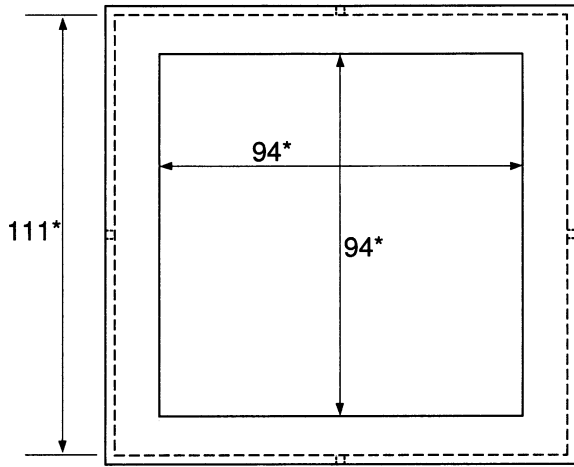

NOTE 1—All dimensions are in millimetres.  
NOTE 2—\* Indicates a critical dimension.

**FIG. 12 Optional Retainer Frame for Horizontal Orientation Testing**

warmup and in between tests to avoid excessive heat transmission to the load cell.

11.1.5 If external ignition is used, position the spark plug holder in the location appropriate to the orientation being used.

**11.2 Procedure:**

11.2.1 When ready to test, if testing in the horizontal orientation, first remove the empty specimen holder.

NOTE 4—When testing in the vertical orientation, the use of an empty specimen holder is not necessary.

11.2.2 Insert the radiation shield and position the specimen, in the appropriate holder, in place. The holder must be at room temperature initially.

11.2.3 Leave the radiation shield in place for a sufficient time to ensure stability of operation (load cell equilibrium), but for no longer than 10 s if the shield is not water cooled. Initiate data collection upon removal of the radiation shield, which signifies the start of the test. The data collection intervals shall be 5 s or less.

11.2.4 Place the specimen, held in the appropriate holder, in place and start the data collection. The data collection intervals

shall be 5 s or less. (The holder must be at room temperature initially.)

11.2.5 Start the ignition timer if external ignition is to be used. Move the spark plug into place and turn on spark power.

11.2.6 Record the times when flashing or transitory flaming occur; when sustained flaming occurs, record the time, turn off the spark, and remove the spark igniter. If the flame extinguishes in less than 60 s after turning off the spark, reinsert the spark igniter and turn on the spark. If flaming recurs, stop the test, discard the test data, and repeat the test without removing the spark until the entire test is completed. Report these events in the test report.

NOTE 5—For reporting the time of sustained flaming, the time to be reported is when the flaming was initially observed, not when the 10 s period elapsed.

11.2.7 Collect data until 2 min after any flaming or other signs of combustion cease, the average mass loss over a 1-min period has dropped below 150 g/m<sup>2</sup>, or until 60 min have elapsed.

11.2.8 Remove specimen holder.

11.2.9 For testing in the horizontal orientation, replace the empty specimen holder.

11.2.10 If the specimen does not ignite in 10 min, remove and discard, unless the specimen is showing signs of heat evolution.

NOTE 6—Stop testing if explosive spalling or excessive swelling occur. The procedures described in 8.1 may be useful in mitigating these effects.

11.2.11 Unless otherwise specified in the material or performance standard, make three determinations and report as specified in Section 14. The 180-s mean heat release rate readings (as specified in Section 14) shall be compared for the three specimens. If any of these mean readings differ by more than 10 % from the average of the three readings, then a further set of three specimens shall be tested. In such cases, report the averages for the set of six readings.

**12. Test Limitations**

12.1 The test data have limited validity if any of the following occur:

12.1.1 In vertical test orientation, the specimen melts sufficiently to overflow the melt trough,

12.1.2 Explosive spalling occurs, or

12.1.3 The specimen swells sufficiently prior to ignition to touch the spark plug or swells up to the plane of the heater base plate during combustion.

**13. Calculation**

13.1 *General*—The equations in this section assume only oxygen is measured, as indicated on the gas analysis system in Fig. 9. Appropriate equations that can be used for cases where additional gas analysis equipment (CO<sub>2</sub>, CO, water vapor) is used are given in Annex A1. If a CO<sub>2</sub> analyzer is used and CO<sub>2</sub> is not removed from the oxygen sampling lines, the equations in Annex A1 must be used.

13.2 *Calibration Constant Using Methane*—Perform the methane calibration daily to check for the proper operation of the instrument and to compensate for minor changes in mass flow determination. (A calibration more than 5 % different

from the previous one is not normal and suggests instrument malfunction.) Compute this calibration constant,  $C$ , from the basic heat release equation (Eq 1) or from Eq 2.

$$5.0 = (12.54 \times 10^3) (1.10) C \sqrt{\frac{\Delta P}{T_c}} \frac{(X_{O_2}^0 - X_{O_2})}{1.105 - 1.5 X_{O_2}} \quad (1)$$

Solved for  $C$ , this gives

$$C = \frac{5.0}{1.10 (12.54 \times 10^3)} \sqrt{\frac{T_c}{\Delta P}} \frac{1.105 - 1.5 X_{O_2}}{X_{O_2}^0 - X_{O_2}} \quad (2)$$

where 5.0 corresponds to 5.0 kW methane supplied,  $12.54 \times 10^3$  is  $\Delta h_c/r_o$  for methane, 1.10 is the ratio of oxygen to air molecular weights, and the variables are given in 3.1. The derivation of the basic Eq 1 is given in Refs (3) and (4).

**13.3 Calculations for Test Specimen**—The following calculations are generally necessary for various applications. The relevant material or performance standard may prescribe additional calculations.

### 13.3.1 Heat Release:

**13.3.1.1** Prior to performing other calculations, the oxygen analyzer time shift is incorporated by the following equation:

$$X_{O_2}(t) = X_{O_2}^1(t + t_d) \quad (3)$$

**13.3.1.2** Then determine the heat-release rate by the following equation:

$$\dot{Q}(t) = \left(\frac{\Delta h_c}{r_o}\right) (1.10) C \sqrt{\frac{\Delta P}{T_c}} \frac{(X_{O_2}^0 - X_{O_2}(t))}{1.105 - 1.5 X_{O_2}(t)} \quad (4)$$

**13.3.1.3** Set the value of  $(\Delta h_c/r_o)$  for the test specimen equal to  $13.1 \times 10^3$  kJ/kg unless a more exact value is known for the test material. Determine the heat-release rate per unit area as follows:

$$\dot{q}''(t) = \frac{\dot{q}(t)}{A_s} \quad (5)$$

where  $A_s$  is the initially exposed area, that is, 0.0088 m<sup>2</sup> in the vertical orientation and in the horizontal orientation if the retainer frame is used, and 0.01 m<sup>2</sup> in the horizontal orientation if the retainer frame is not used.

**13.3.1.4** Determine the total heat released during combustion,  $q''$ , by summation as follows:

$$q'' = \sum_i \dot{q}''_i(t) \Delta t \quad (6)$$

where the summation begins at the next reading after the last negative rate of heat release reading occurred at the beginning of the test, and continuing until the final reading recorded for the test.

**13.3.2 Mass-Loss Rate and Effective Heat of Combustion**—Compute the required mass-loss rate,  $-dm/dt$ , at each time interval using five-point numerical differentiation. The equations to be used are as follows:

**13.3.2.1** For the first scan ( $i = 0$ ):

$$-\left[\frac{dm}{dt}\right]_{i=0} = \frac{25m_0 - 48m_1 + 36m_2 - 16m_3 + 3m_4}{12\Delta t} \quad (7)$$

**13.3.2.2** For the second scan ( $i = 1$ ):

$$-\left[\frac{dm}{dt}\right]_{i=1} = \frac{3m_0 + 10m_1 - 18m_2 + 6m_3 - m_4}{12\Delta t} \quad (8)$$

**13.3.2.3** For any scan for which  $1 < i < n - 1$  (where  $n$

= total number of scans):

$$-\left[\frac{dm}{dt}\right]_i = \frac{-m_{i-2} + 8m_{i-1} - 8m_{i+1} + m_{i+2}}{12\Delta t} \quad (9)$$

**13.3.2.4** For the last scan but one ( $i = n - 1$ ):

$$-\left[\frac{dm}{dt}\right]_{i=n-1} = \frac{-3m_n - 10m_{n-1} + 18m_{n-2} - 6m_{n-3} + m_{n-4}}{12\Delta t} \quad (10)$$

**13.3.2.5** For the last scan ( $i = n$ ):

$$-\left[\frac{dm}{dt}\right]_{i=n} = \frac{-25m_n + 48m_{n-1} - 36m_{n-2} + 16m_{n-3} - 3m_{n-4}}{12\Delta t} \quad (11)$$

**13.3.2.6** Determine the average effective heat of combustion as follows:

$$\Delta h_{c,\text{eff}} = \frac{\sum_i \dot{q}_i(t) \Delta t}{m_i - m_f} \quad (12)$$

with the summation taken over the entire test length. A time-varying value is also determined as follows:

$$\Delta h_{c,\text{eff}}(t) = \frac{\dot{q}_i(t)}{-(dm/dt)} \quad (13)$$

### 13.3.3 Smoke Obscuration:

**13.3.3.1** Determine the extinction coefficient,  $k$ , by the smoke meter electronics as follows:

$$k = \left(\frac{1}{L}\right) \ln \frac{I_o}{I} \quad (14)$$

**13.3.3.2** The average specific extinction area obtained during the test is given as follows:

$$\sigma_{f(\text{Avg})} = \frac{\sum_i \dot{V}_i k_i \Delta t_i}{m_i - m_f} \quad (15)$$

## 14. Report

**14.1** Report the following information unless specified otherwise in the relevant material or performance standard. Clearly state the units for all measurements in the report. Certain units convenient for reporting are suggested in parentheses.

**14.1.1** Specimen identification code or number.

**14.1.2** Manufacturer or submitter.

**14.1.3** Date of test.

**14.1.4** Operator.

**14.1.5** Composition or generic identification.

**14.1.6** Specimen thickness.<sup>8</sup>

**14.1.7** Specimen mass.<sup>8</sup>

**14.1.8** Color of the specimens.

**14.1.9** Details of specimen preparation by the testing laboratory.

**14.1.10** Test orientation, specimen mounting, and whether the retainer frame, the wire grid, or other special mounting procedures were used.

**14.1.11** Heating flux and exhaust system flow rate.<sup>8</sup>

**14.1.12** Number of replicate specimens tested under the

<sup>8</sup> Report these items for each specimen.

same conditions. (This shall be a minimum of three, except for exploratory testing.)

14.1.13 Time to sustained flaming (seconds).<sup>8</sup> If sustained flaming was not observed, record that there was no ignition.

14.1.14 Heat-release rate (per unit area) curve (kW/m<sup>2</sup>).<sup>8</sup>

14.1.15 Peak  $\dot{q}''$ , and average  $\dot{q}''$  values for the first 60, 180, and 300 s after ignition, or for other appropriate periods (kW/m<sup>2</sup>).<sup>7</sup> For specimens that do not show sustained flaming, report the above quantities tabulated for periods beginning with the next reading after the last negative rate of heat release reading at the beginning of the test.

NOTE 7—Average rate of heat release values are to be calculated using the trapezium rule for integration. For example, with a 5 s data collection interval,  $\dot{q}''_{180}$  is obtained as follows: (1) Sum up all rate of heat release values at the second through thirty-sixth scan after ignition or the last negative value (if the test is completed before the 180 s period is elapsed, use the test average instead); (2) Add half of the rate of heat release measured at the first scan and at the thirty-seventh scan after ignition or after the last negative value; (3) Multiply the sum obtained in (2) by the scan interval (5 s) and divide it by 180.

14.1.16 Total heat released by the specimen (MJ/m<sup>2</sup>) as determined in 12.3.1.4.<sup>8</sup>

14.1.17 Average  $\Delta h_{c,eff}$  for entire test (MJ/kg).<sup>8</sup>

14.1.18 Curve of  $\Delta h_{c,eff}$  (MJ/kg) (optional).<sup>8</sup>

14.1.19 Mass remaining after test (g).<sup>8</sup>

14.1.20 Sample mass loss (kg/m<sup>2</sup>).<sup>8</sup> The average specimen mass loss rate (g/m<sup>2</sup>-s), computed over the period starting when 10 % of the ultimate specimen mass loss occurred and ending at the time when 90 % of the ultimate specimen mass loss occurred.

14.1.21 Smoke obscuration. Report the average specific extinction area (m<sup>2</sup>/kg).<sup>8</sup>

14.1.22 Values determined in 14.1.13, 14.1.15, 14.1.17, and 14.1.21, averaged for all specimens.

14.1.23 Additional observations (including times of transitory flaming or flashing), if any.<sup>8</sup>

14.1.24 Difficulties encountered in testing, if any.<sup>8</sup>

## 15. Precision and Bias<sup>9</sup>

### 15.1 Precision:

15.1.1 Interlaboratory trials were conducted by Committee E05 to determine the repeatability and reproducibility of this test method. The results were analyzed in conjunction with the results of a parallel set of inter-laboratory trials sponsored by the International Organization for Standardization (ISO). The complete results have been placed on file at ASTM headquarters as a Research Report. The results obtained for repeatability and reproducibility are given below; further details of the interlaboratory trials are given in Appendix X2.

15.1.2 The following definitions of repeatability ( $r$ ) and reproducibility ( $R$ ) are used:

$$r = f\sqrt{2} \sigma_r \quad (16)$$

$$R = f\sqrt{2} \sigma_R \quad (17)$$

where  $\sigma_r$  is the repeatability standard deviation,  $\sigma_R$  is the reproducibility standard deviation, the coefficient  $\sqrt{2}$  is

derived from the fact that  $r$  and  $R$  refer to the difference between two single test results, and  $f$ , which is approximately 2, corresponds to the probability level of 95 % being taken. This product is then rounded off:

$$r = 2.8 s_r \quad (18)$$

$$R = 2.8 s_R \quad (19)$$

For calculations, the sample-based standard deviation estimates,  $s$ , are substituted for the population standard deviations,  $\sigma$ , since the latter are not known.

15.1.3 For the materials tested, values for repeatability  $r$  and reproducibility  $R$  have been calculated for six variables. These variables, chosen as being representative for the test results are:  $t_{ig}$ ,  $\dot{q}''_{max}$ ,  $\dot{q}''_{180}$ ,  $q''_{tot}$ ,  $\Delta h_{c,eff}$ , and  $\sigma_f$ . A linear regression model was used to describe  $r$  and  $R$  as a function of the mean over all replicates and over all laboratories for each of the six variables. The regression equations are given below. The range of mean values over which the fit was obtained is also indicated. The results for time to sustained flaming,  $t_{ig}$ , in the range of 5 to 150 s were:

$$r = 4.1 + 0.125 t_{ig} \quad (20)$$

$$R = 7.4 + 0.220 t_{ig} \quad (21)$$

The results for peak heat release rate,  $\dot{q}''_{max}$ , in the range of 70 to 1120 kW/m<sup>2</sup> were:

$$r = 13.3 + 0.131 \dot{q}''_{max} \quad (22)$$

$$R = 60.4 + 0.141 \dot{q}''_{max} \quad (23)$$

The results for 180-s average heat release rate,  $\dot{q}''_{180}$ , in the range of 70 to 870 kW/m<sup>2</sup> were:

$$r = 23.3 + 0.037 \dot{q}''_{180} \quad (24)$$

$$R = 25.5 + 0.151 \dot{q}''_{180} \quad (25)$$

The results for total heat released,  $q''_{tot}$ , in the range of 5 to 720 MJ/m<sup>2</sup> were:

$$r = 7.4 + 0.068 q''_{tot} \quad (26)$$

$$R = 11.8 + 0.088 q''_{tot} \quad (27)$$

The results for effective heat of combustion,  $\Delta h_{c,eff}$ , in the range of 7 to 40 kJ/g were:

$$r = 1.23 + 0.050 \Delta h_{c,eff} \quad (28)$$

$$R = 2.42 + 0.055 \Delta h_{c,eff} \quad (29)$$

The results for average specific extinction area,  $\sigma_f$ , in the range of 30 to 2200 m<sup>2</sup>/kg were:

$$r = 59 + 0.076 \sigma_f \quad (30)$$

$$R = 63 + 0.215 \sigma_f \quad (31)$$

15.2 Bias—For solid specimens of unknown chemical composition, as used in building materials, furnishings, and common occupant fuel load, it has been documented that the use of the oxygen consumption standard value of  $\Delta h_c / r_o = 13.1 \times 10^3$  kJ/kg oxygen results in an expected error band of  $\pm 5$  % compared to true value (1). For homogeneous materials with only a single pyrolysis mechanism, this uncertainty can be reduced by determining  $\Delta h_c$  from oxygen bomb measurements and  $r_o$  from ultimate elemental analysis. For most testing, this is not practical since specimens may be composite and nonhomogeneous, and may exhibit several degradation reactions. Therefore, for unknown samples a

<sup>9</sup> Supporting data are available from ASTM Headquarters. Request RR: E05-1008.



±5 % accuracy limit is seen. For reference materials, however, careful determination of  $\Delta h_c/r_o$  can make this source of uncertainty substantially less.

## 16. Keywords

16.1 cone calorimeter; heat—heat release rate;

ignitability—radiant ignition; mass—mass loss rate; oxygen consumption method—heat release rate; smoke

## ANNEX

### (Mandatory Information)

#### A1. CALCULATION OF HEAT RELEASE WITH ADDITIONAL GAS ANALYSIS

##### A1.1 Introduction

A1.1.1 The equations to calculate heat release rate in Section 12 assume CO<sub>2</sub> is removed from the gas sample in a chemical scrubber before oxygen is measured, as indicated in Fig. 9. Some laboratories are equipped to measure CO<sub>2</sub>; in that case it is not necessary to remove the CO<sub>2</sub> from the oxygen line. The advantage, in that case, is that it is possible to avoid the chemical scrubbing agent, which is costly and requires careful handling.

A1.1.2 In this annex equations are given that are to be used when CO<sub>2</sub> is measured but not scrubbed out of the sampling lines. Two cases are considered. In the first case, part of the dried and filtered sample stream is diverted into infrared CO<sub>2</sub> and CO analyzers (see option in Fig. 9). In the second case, a water-vapor analyzer is also added. To avoid condensation, the measuring of water vapor concentration in the flow of combustion products requires a separate sampling system with heated filters, heated sampling lines, and a heated analyzer.

##### A1.2 Symbols

A1.2.1 The following symbols are used in this annex.

$M_a$	= molecular weight of air (kg/kmol).
$M_e$	= molecular weight of the combustion products (kg/kmol).
$\dot{m}_e$	= exhaust duct mass flow rate (kg/s).
$t_{d1}$	= delay time of the CO <sub>2</sub> analyzer(s).
$t_{d2}$	= delay time of the CO analyzer(s).
$t_{d3}$	= delay time of the water vapor analyzer(s).
$X_{CO_2}^0$	= initial CO <sub>2</sub> reading, mole fraction (–).
$X_{CO}^0$	= initial CO reading, mole fraction (–).
$X_{H_2O}^0$	= initial water vapor reading, mole fraction (–).
$X_{O_2}^a$	= ambient oxygen mole fraction (–).
$X_{CO_2}^1$	= CO <sub>2</sub> reading before delay time correction, mole fraction (–).
$X_{CO}^1$	= CO reading before delay time correction, mole fraction (–).
$X_{H_2O}^1$	= water vapor reading before delay time correction, mole fraction (–).
$X_{CO_2}$	= CO <sub>2</sub> reading after delay time correction, mole fraction (–).
$X_{CO}$	= CO reading after delay time correction, mole fraction (–).

$X_{H_2O}$  = water reading after delay time correction, mole fraction (–).

$\phi$  = oxygen depletion factor (–).

##### A1.3 References

A1.3.1 Eq A1.5, Eq A1.6, and Eq A1.10 are derived in Ref (3).

##### A1.4 Case Where CO<sub>2</sub> and CO are Also Measured

A1.4.1 Just as for the oxygen analyzer, measurements of CO<sub>2</sub> and CO shall be time shifted to take transport time in the sampling lines into account as follows:

$$X_{O_2}(t) = X_{O_2}^1(t + t_d) \quad (A1.1)$$

$$X_{CO_2}(t) = X_{CO_2}^1(t + t_d^1) \quad (A1.2)$$

$$X_{CO}(t) = X_{CO}^1(t + t_d^1) \quad (A1.3)$$

Here, the delay times  $t_d^1$  and  $t_d^2$  for the CO<sub>2</sub> and CO analyzers respectively are usually different (smaller) than the delay time  $t_d$  for the oxygen (O<sub>2</sub>) analyzer.

A1.4.2 The exhaust duct flow is as follows:

$$\dot{m}_e = C \sqrt{\frac{\Delta P}{T_e}} \quad (A1.4)$$

A1.4.3 The rate of heat release shall in that case be determined as follows:

$$\dot{q} = 1.10 \left( \frac{\Delta h_c}{r_o} \right) X_{O_2}^1 \left[ \frac{\phi - 0.172(1 - \phi) X_{CO} / X_{O_2}}{(1 - \phi) + 1.105 \phi} \right] \dot{m}_e \quad (A1.5)$$

A1.4.4 The oxygen depletion factor,  $\phi$ , is calculated as follows:

$$\phi = \frac{X_{O_2}^1(1 - X_{CO_2} - X_{CO}) - X_{O_2}(1 - X_{CO_2}^0)}{X_{O_2}^1(1 - X_{CO_2} - X_{CO} - X_{O_2})} \quad (A1.6)$$

A1.4.5 The ambient mole fraction of oxygen (O<sub>2</sub>) is as follows:

$$X_{O_2}^a = (1 - X_{H_2O}^0) X_{O_2}^0 \quad (A1.7)$$

A1.4.6 The second term in the numerator of the factor in brackets in Eq A1.5 is a correction for incomplete combustion of some carbon to CO instead of CO<sub>2</sub>. In fact,  $X_{CO}$  is usually very small, shall be permitted to be neglected in Eq A1.5 and Eq A1.6. The practical implication of this is that a CO analyzer will generally not result in a noticeable increase in accuracy of heat release rate measurements. Consequently Eq A1.5 and Eq

A1.6 shall be permitted to be used even if no CO analyzer is present, by setting  $X_{CO} \equiv 0$ .

### A1.5 Case Where Water Vapor is Also Measured

A1.5.1 In an open combustion system, such as that used in this test method, the flow rate of air entering the system cannot be measured directly but is inferred from the flow rate measured in the exhaust duct. An assumption is required regarding the expansion due to combustion of the fraction of the air that is fully depleted of its oxygen. This expansion depends on the composition of the fuel and the actual stoichiometry of the combustion. A suitable average value for the volumetric expansion factor is 1.105, which is correct for methane.

A1.5.2 This number is already incorporated within Eq 3 and Eq A1.5 for  $\dot{q}$ . For cone calorimeter tests it is reasonable to assume that the exhaust gases consist primarily of nitrogen, oxygen, CO<sub>2</sub>, water vapor, and CO; thus, measurements of these gases shall be permitted to be used to determine the actual expansion. (It is assumed that the measurements of oxygen, CO<sub>2</sub>, and CO refer to a dry gas stream, while the water vapor measurement is with respect to total stream flow.) The

mass flow rate in the exhaust duct is then more accurately given by the following equation:

$$\dot{m}_e = \sqrt{M_e/M_a} C \sqrt{\frac{\Delta P}{T_e}} \quad (\text{A1.8})$$

A1.5.2.1 The molecular weight  $M_e$  of the exhaust gases follows from:

$$M_e = [4.5 + (1 - X_{H_2O})(2.5 + X_{O_2} + 4X_{CO_2})] \times 4 \quad (\text{A1.9})$$

A1.5.2.2 Then taking  $M_a$  as 28.97, the heat release rate is given as follows:

$$\dot{q} = 1.10 \left( \frac{\Delta h_c}{r_o} \right) (1 - X_{H_2O}) X_{O_2}^o \left[ \phi - 0.172(1 - \phi) \left( \frac{X_{CO}}{X_{O_2}} \right) \right] \quad (\text{A1.10})$$

$$\left[ \frac{1 - X_{O_2} - X_{CO_2} - X_{CO}}{1 - X_{O_2}^o - X_{CO_2}^o} \right] \dot{m}_e$$

A1.5.3 The water vapor readings used in Eq A1.10 are time shifted in a similar way as in Eq A1.1-A1.3 for the other analyzers as follows:

$$X_{H_2O}^0(t) = X_{H_2O}^1(t + t_d^3) \quad (\text{A1.11})$$

## APPENDIXES

### (Nonmandatory Information)

#### X1. COMMENTARY

##### X1.1 Introduction

X1.1.1 This commentary is provided (1) to give some insight into the development of the test method, (2) to describe the rationale for the design of various features of the apparatus, and (3) to describe the use of the data.

##### X1.2 Rate of Heat Release Rate Measurements

X1.2.1 The rate of heat release is one of the most important variables, in many cases the single most important variable, in determining the hazard from a fire (4). This rate of heat release is the total rate, as a function of time. With many items composed of many surfaces contributing to the fire, its evaluation is quite complex. For each separate surface it must first be determined when, if at all, it will become ignited. The size of the fire from any already burning items must be known, since that constitutes the external irradiance to nearby items. Next, the flame spread over the surface in question must be evaluated. The rate of heat release from the whole surface can be evaluated knowing the rate of heat release per unit area for a given irradiance, as a function of time. This last quantity is the only one that can be measured in a bench-scale test. The total fire output involves a summation over all surfaces. Also to be considered is the fact that some elements may burn out and then no longer contribute to the fire. This procedure is conceptually straightforward but can be very cumbersome to compute.

X1.2.2 Many common combustibles do not have the geometrically simple surfaces required to make computations of

this kind. Other complications, such as melting, dripping, or collapsing, can also preclude a detailed mathematical analysis. In such cases a simpler, more empirical model is appropriate. An example of the use of bench-scale heat release rate measurements in deriving a fire hazard assessment is available (5).

X1.2.3 This test method does not prescribe the irradiance levels, nor whether external ignition is to be used. These must be determined separately for each product class. For a given class of applications and products, a comparison with some full-scale fires is generally necessary to determine the time period over which the heat release rate is to be calculated. A material or performance standard can then be developed for that product category that may contain further guidance and limitations for testing. For exploratory testing, it is initially recommended to use the horizontal orientation and an irradiance value of 35 kW/m<sup>2</sup>; in the absence of further specifications from the sponsor, tests at 25, 35, and 50 kW/m<sup>2</sup> are recommended.

X1.2.3.1 The standard specimen orientation for testing is horizontal. This is applicable even to specimens, such as wall linings, where the end-use orientation of the product is vertical. The reason is that this test method does not represent a scale model of the full-scale product. Instead, the fundamental response of a specimen to specified external irradiance is tested. The total heating to the specimen is the sum of the external irradiance plus the heat flux from the specimen's own flame. The heat flux from the specimen's flames will be

different in the two orientations. What must be borne in mind is that there is no fixed relationship between this flame flux for the bench-scale specimen compared to the full-scale product. Instead, the relationship varies in accordance with product application, as explained in X1.2.3. The relationship between the bench-scale heat release rate and the one in full-scale must establish a test irradiance value that correctly accounts for the fact that the full-scale product is exposed to a different flame flux than the bench-scale specimen.

X1.2.3.2 The standard testing orientation is horizontal since, for most types of specimens, there are significantly fewer experimental problems due to specimen melting, dripping, or falling out. Reproducibility of ignition data is also better in this orientation, due to a wider column of pyrolysates present at the location of the spark gap. The vertical orientation is made available because in certain diagnostic studies it is more feasible to install optical pyrometers, specimen thermocouples, and other specialized instrumentation in that orientation.

X1.2.3.3 The test results may not be statistically significant unless the irradiance used is substantially (5 to 10 kW/m<sup>2</sup>) higher than the minimum irradiance level needed for sustained flaming to occur for that specimen.

### X1.3 Choice of Operating Principle

X1.3.1 A number of apparatus have been developed over the years for measuring rate of heat release; most of these have been reviewed in detail (6). Traditionally, the simplest measurement scheme is a direct measurement of flow enthalpy from a chamber thermally lagged to present an adiabatic environment. A truly adiabatic apparatus, with the use of guard heaters, would be possible but would also be prohibitively expensive and has not been implemented. A combustion chamber insulated in a simpler manner leads to a significant under measurement of the heat release, so only an empirical calibration is possible. An example of an insulated chamber method is Test Method E 906. Furthermore, that calibration may be sensitive to the radiant fraction (or sootiness) of the combustible (7, 8). A more advanced scheme is an isothermal instrument, rather than an adiabatic one, with the heat-release rate taken to be the fuel which must be supplied by a substitution burner to maintain isothermal conditions (9). This scheme gives better results, since only second-order heat loss error terms remain; however, its practical implementation is complex and costly.

X1.3.2 It can be concluded that it is difficult to measure heat directly without losing some of it. However, it is simple to capture all combustion products without losing any and to measure the oxygen levels in that stream. Heat release can be computed from such measurements with the availability of the oxygen-consumption principle (1). This principle states that for most common combustibles an amount of heat equal to  $13.1 \times 10^3$  kJ is released for each kilogram of oxygen consumed from the air stream. This constant varies  $\pm 5$  % for most common combustibles; certain exceptions are given in Ref (1). The method remains useful even if a significant fraction of the products become CO or soot, rather than CO<sub>2</sub>; in these cases, correction terms are known (1, 3) and can be applied. A typical case of less than 2 % error has been determined to result for cellulose producing 10 % incomplete combustion going to CO

(1). Note that excessively high CO-production values, which could result from restricted oxygen supply, cannot result in the calorimeter used in this test method since oxygen intake is not restricted. By adopting the oxygen consumption principle as the method of measurement, it becomes possible to design an apparatus of significantly improved precision but without excessive complexity. Since heat measurements are not required, the apparatus does not need thermal insulation.

### X1.4 Heater Design

X1.4.1 Experience with various rate-of-heat-release measurement techniques suggests that for minimal errors in irradiance, the specimen should see only (1) a thermostatically controlled heater, (2) a water-cooled plate, or (3) open air. Nearby solid surfaces, if they are not temperature-controlled, can rise in temperature due to specimen flame heating and then act as further sources of radiation back to the specimen. Further, when oxygen consumption is used as the measurement principle, a gas-fired heater is not desirable because it can contribute a noisy baseline to the oxygen readings, even though it can be subtracted out in steady state.

X1.4.2 A heater in the shape of a truncated cone was first explored for use in an ignitability apparatus by the International Organization for Standardization (ISO) (see ISO 5657-1986). The heater adopted in the present method is similar, but not identical to the ISO one. The main differences include higher heat fluxes, temperature control, and more rugged design details. In the horizontal orientation, the conical shape approximately follows the fire plume contours while the central hole allows the stream to emerge without impacting on the heater. A thin layer of cool air is pulled along, and the flames do not attach to the sides of the cone. The central hole has a further function: in its absence the middle of the specimen would receive a higher irradiance than the edges. With the hole, the irradiance is uniform to within  $\pm 2$  %. In the vertical orientation, the hole still serves the purpose of providing radiation uniformity; although because of the presence of a natural convection boundary layer, the deviations are higher (from  $\pm 5$  to  $\pm 10$  %) (10).

### X1.5 Pilot Ignition

X1.5.1 Ignition of test specimens in many apparatus is achieved by a gas pilot. This tends to have numerous difficulties—sooting, deterioration of orifices, and contribution to the heat release rate. It is difficult to design a pilot that can be centrally located over the specimen, is resistant to blowout, and yet does not apply an additional heating flux to the specimen. (A point of elevated heating on the specimen makes it difficult to analyze mathematically the response of the specimen.) An electric spark is free of most of these difficulties, requiring only an occasional cleaning and adjustment of the electrodes. For these reasons, an electric spark ignition was adopted.

### X1.6 Back Face Conditions

X1.6.1 The heat losses through the specimen back face can have an influence on the burning rate near the end of its burning time. For reproducible measurements, the losses through the back face should be standardized. The simplest

theoretical boundary conditions—an adiabatic boundary or an isothermal one at ambient temperature—are not achievable. However, a reasonable approximation to the former can be made by using a layer of an insulating material. This is easier to do for the horizontal orientation case, in which case a very low density refractory blanket is used. In the vertical orientation some structural rigidity of the backing is desired; consequently, a layer of higher density backing may be necessary.

### X1.7 Oxygen Analyzer

X1.7.1 The analyzer should be of the paramagnetic type, with baseline noise and short-term drift of approximately  $\pm 50$  ppm oxygen. Other types of analyzers (electrochemical and catalytic) generally cannot meet this requirement. Paramagnetic analyzers also exhibit an intrinsically linear response. The linearity is normally better than can be determined with  $\pm 0.1$  % oxygen gas mixtures. Since an oxygen analyzer is sensitive to stream pressures, either the readings have to be compensated with an absolute pressure transducer, connected to the analyzer, or the pressure has to be mechanically regulated both against flow fluctuations and atmospheric pressure variations. The analyzer and the pressure regulating or measuring devices must be located in a constant temperature environment to avoid flow errors.

### X1.8 Limits to Resolution

X1.8.1 Methane calibration studies (10) showed typical fluctuations of  $\pm 1.5$  %, with a linearity to within 5 % over the range of 1 to 12 kW, and within 2 % over the range of 5 to 12 kW. Calibrations with other gases show similar results. Calibration gases can be delivered to the burner in a highly steady manner. The uniformity of solid-fuels combustion, however, is governed by the pyrolysis at the surface, which can under some circumstances show substantial fluctuations. For instance, the fluctuations for polymethylmethacrylate are greater than for red oak (10). Burning thermoplastic specimens occasionally eject individual molten streamers. With solid materials then, the limits to resolution can be expected to be set by the specimen pyrolysis process, rather than by instrument limits.

X1.8.2 The limits to the speed of response of any heat release rate technique are set by the slowest responding element. In the case of the present method, this is the oxygen analyzer, which typically shows a 10 to 90 % response time of 6.9 s. Response times of the pressure transducer and thermocouple can be much faster. They should be set to be only somewhat faster, however, to avoid introducing instrument noise without increasing resolution.

### X1.9 Effective Heat of Combustion

X1.9.1 The effective heat of combustion is a constant during combustion of homogeneous specimens having only a single mode of degradation and is less than the value of the theoretical net heat of combustion. Examples of a material with a single mode of degradation and, therefore, a constant effective heat of combustion include most organic liquids. Cellulosic products, by contrast, typically show more than one mode of degradation and a varying effective heat of combustion. For materials having more than one mode of degradation, or for composites or nonhomogeneous materials, the effective heat of combustion

is not necessarily constant.

### X1.10 Smoke Obscuration Measurements

X1.10.1 The smoke measurement system is different from that used in Test Method E 662 for the following reasons:

X1.10.1.1 Simultaneous mass measurements are available,

X1.10.1.2 Irradiances up to 100 kW/m<sup>2</sup> are available,

X1.10.1.3 The combustion takes place in a flow stream, not in a closed box, and

X1.10.1.4 A monochromatic light source is used.

X1.10.2 Accurate measurement of smoke obscuration requires, among other considerations, the following:

X1.10.2.1 A highly collimated light source, insensitive to stray light,

X1.10.2.2 Measurement in a well mixed unstratified stream,

X1.10.2.3 A high degree of stability against drift due to voltage fluctuations, source aging, thermal effects, etc., and

X1.10.2.4 The ability to make extended measurements without error due to progressive coating of optics by soot.

X1.10.3 In addition, it is desirable to select a monochromatic source (11), preferably in the red portion of the spectrum, for ease of interpreting the data in accordance with the theoretical models. For convenience, it is also desirable to provide direct electric output in logarithmic units to avoid the need for manual range switching or resulting inaccuracies at the high end of the scale. An instrument has been designed that is intended to meet all these requirements (Fig. 11) (12). Additional construction details are given in construction drawings.<sup>10</sup> The theory for data analysis is from Refs (13) and (14).

### X1.11 Specimen Mounting Methods

X1.11.1 This test method is a general method suitable for testing different types of products and materials. In the simplest case, the product or material is cut out to the correct size, wrapped in aluminum foil, and placed in the horizontal or vertical specimen holder. In many cases, however, the specimen, when heated, may warp, intumescence, delaminate, or burn in an unrepresentative manner along its side edges. Two common procedures for handling such specimens are described in this test method: an edge frame (pertinent only to horizontal orientation testing) and a wire grid (either orientation). These are not the only specimen mounting methods available to the testing laboratory. Reference (2) suggests some additional procedures. For more unusual specimen types, the testing laboratory will have to devise appropriate mounting methods. Since different mounting methods may give different test results, the method used must be documented in the test report, as mandated in 14.1.10. Since test results are inevitably affected by such mounting devices, they should not be used unless prior testing indicates they are necessary to alleviate anomalous burning conditions.

X1.11.2 For building products, the use of the retainer frame is recommended for testing in the horizontal orientation. For other product classes, the usage shall be in accordance with the governing application standard.

<sup>10</sup> Construction drawings for the Cone Calorimeter are available from the Building and Fire Research Laboratory, National Institute of Standards and Technology, Gaithersburg, MD 20899.



## X2. INTERLABORATORY TRIALS

### X2.1 Scope of Studies

X2.1.1 For the ASTM interlaboratory trials, six laboratories tested the following materials: 6 mm fire retardant treated ABS ( $\rho = 325 \text{ kg/m}^3$ ); 12 mm particleboard ( $\rho = 640 \text{ kg/m}^3$ ); 6 mm black PMMA ( $\rho = 1180 \text{ kg/m}^3$ ); 6 mm polyethylene ( $\rho = 800 \text{ kg/m}^3$ ); 6 mm PVC ( $\rho = 1340 \text{ kg/m}^3$ ); and 25 mm rigid polyisocyanurate foam ( $\rho = 280 \text{ kg/m}^3$ ). For most of these materials, three replicates each were tested in two orientations (horizontal and vertical) and at two irradiance levels (25 and 50  $\text{kW/m}^2$ ).

X2.1.2 Data from the ASTM trials were supplemented by data developed during an analogous set of trials conducted by ISO, using functionally the same protocol. The materials tested in the ISO trials were: 25 mm black PMMA ( $\rho = 1180 \text{ kg/m}^3$ ) [same material as tested by ASTM, but in a different thickness]; 30 mm rigid polyurethane foam ( $\rho = 33 \text{ kg/m}^3$ ); 12 mm particleboard ( $\rho = 640 \text{ kg/m}^3$ ) [same material as tested by ASTM]; 3 mm hardboard ( $\rho = 1010 \text{ kg/m}^3$ ); 10 mm gypsum board ( $\rho = 1110 \text{ kg/m}^3$ ); and 10 mm fire retardant treated particleboard ( $\rho = 750 \text{ kg/m}^3$ ). For most of these materials, three replicates each were tested in two orientations (horizontal and vertical) and at two irradiance levels (25 and 50  $\text{kW/m}^2$ ) by six to eight laboratories.

### X2.2 Method of Analysis

X2.2.1 Basic guidance was received from Practices E 177 and E 691. However, these practices refer to various possibilities of reporting repeatability and reproducibility at 1.0, 2.0, 2.83, or 3.0 times the pertinent standard deviations. The standard deviation may be computed with respect to the average value or with respect to two sets of results. Furthermore, they leave the treatment of outliers largely to the discretion of the analyst. This presents certain difficulties in comparing results to other studies. It was, specifically, desired to treat the ASTM and ISO trials in a similar manner. The solution was found in adopting the prescriptions contained in ISO 5725. The ISO standard, which can be viewed as a stricter subset of the ASTM instructions, prescribes a single fixed procedure. It mandates that repeatability and reproducibility be reported to 2.8 standard deviations, and also provides fixed instructions on how to handle the issue of outliers.

X2.2.2 The ASTM and ISO results were first analyzed separately in accordance with the equations given in ISO 5725. The results for both series were found to be expressible as a linear error model, defined by Eq II in Par. 15.2 of ISO 5725.

Furthermore, in all the cases where valid data were available from both series, the relationships for  $r$  and  $R$  showed very similar behavior. This allowed best estimate relationships for  $r$  and  $R$  to be derived from the combined data set (in cases where valid data were obtained in both series). The equations given in 14.1.3 constitute these best estimate values.

### X2.3 Example of Using $r$ and $R$ Relationships

X2.3.1 The meaning of the equations for  $r$  and  $R$  given in 14.1.3 is best illustrated by means of an example. Suppose a laboratory tests a single sample of a certain material and determines that the time to ignition (sustained flaming) is 100 s. If the same laboratory now conducts a second test on the same material, the value of  $r$  is evaluated as:

$$r = 4.1 + 0.125 \times 100 = 17 \text{ s}$$

Then  $100 - r = 83$  and  $100 + r = 117$ ; thus, the probability is 95 % that the result of the second test will fall between 83 and 117 s.

Suppose now that the same material is tested by a different laboratory. The value of  $R$  is evaluated as:

$$R = 7.4 + 0.220 \times 100 = 29 \text{ s}$$

Then  $100 - R = 71$  and  $100 + R = 129$ ; thus, the probability is 95 % that the results from the test at that laboratory will fall between 71 and 129 s.

### X2.4 Comparison to Results for Other Fire Tests

X2.4.1 A number of interlaboratory trials have been conducted on various fire tests. For most of them, the data would be difficult to compare, since the methods of analysis were not the same in each case. Since the present trials were analyzed in accordance with the specific prescription mandated by ISO 5725, however, it is possible to find an example that is directly comparable. This is the ISO radiant ignition test, ISO 5657. This test is especially interesting to compare since it uses a conical heater somewhat similar to the one used on the present test method. Since that test is only a test for ignitability, only one variable is examined, the  $t_{ig}$ . The results of the ISO 5657 trials, analyzed in the same manner, were:

$$r = 2.9 + 0.241 t_{ig} \quad (\text{X2.1})$$

$$R = 2.2 + 0.458 t_{ig} \quad (\text{X2.2})$$

Comparison with Eq 20 and Eq 21 shows that, over most of the range, both the repeatability and reproducibility for the present test method are substantially better (smaller) than for the ISO 5657 test.

## REFERENCES

- (1) Huggett, C., “Estimation of Rate of Heat Release by Means of Oxygen Consumption Measurements,” *Fire and Materials*, Vol 4, 1980, pp. 61–65.
- (2) Twilley, W. H., and Babrauskas, V., “User’s Guide for the Cone Calorimeter,” *NBS Special Publication SP 745*, National Bureau of Standards, 1988.
- (3) Parker, W. J., “Calculations of the Heat Release Rate by Oxygen Consumption for Various Applications” *NBSIR 81-2427*, National Bureau of Standards, 1982.
- (4) Babrauskas, V., Lawson, J. R., Walton, W. D., and Twilley, W. H., “Upholstered Furniture Heat Release Rates Measured with a Furniture Calorimeter,” *NBSIR 82-2604*, National Bureau of Standards, 1982.
- (5) Babrauskas, V., and Krasny, J. F., “Prediction of Upholstered Chair Heat Release Rates from Bench-Scale Measurements,” *Fire Safety Science and Engineering*, *ASTM STP 882*, ASTM, 1985, p. 268.
- (6) Janssens, M., “Calorimetry,” *The SFPE Handbook of Fire Protection Engineering*, 2nd Edition, 1995, pp. 3–16 through 3–36.
- (7) Babrauskas, V., “Performance of the Ohio State University Rate of Heat Release Apparatus Using Polymethylmethacrylate and Gaseous Fuels,” *Fire Safety Journal*, Vol 5, 1982, pp. 9–20.
- (8) Krause, R. F., and Gann, R. G., “Rate of Heat Release Measurements Using Oxygen Consumption,” *Journal of Fire and Flammability*, Vol 11, April 1980, pp. 117–130.
- (9) Tordella, J., and Twilley, W. H., “Development of a Calorimeter for Simultaneously Measuring Heat Release and Mass Loss Rates,” *NBSIR 83 2708*, National Institute of Standards and Technology, 1983.
- (10) Babrauskas, V., “Development of the Cone Calorimeter—A Bench Scale Heat Release Rate Apparatus Based on Oxygen Consumption,” *NBSIR 82-2611*, National Bureau of Standards, 1982.
- (11) Mulholland, G., “How Well Are We Measuring Smoke?,” *Fire and Materials*, Vol 6, 1982, pp. 65–67.
- (12) Babrauskas, V., and Mulholland, G., “Smoke and Soot Data Determinations in the Cone Calorimeter,” *Mathematical Modeling of Fires*, *ASTM STP 983*, ASTM, 1987, pp. 83–104.
- (13) Babrauskas, V., “Applications of Predictive Smoke Measurements,” *Journal of Fire and Flammability*, Vol 12, January 1981, pp. 51–54.
- (14) Babrauskas, V., “Effective Measurement Techniques for Heat, Smoke, and Toxic Gases,” *Fire Safety Journal*, Vol 17, 1991, pp. 13–26.

*ASTM International takes no position respecting the validity of any patent rights asserted in connection with any item mentioned in this standard. Users of this standard are expressly advised that determination of the validity of any such patent rights, and the risk of infringement of such rights, are entirely their own responsibility.*

*This standard is subject to revision at any time by the responsible technical committee and must be reviewed every five years and if not revised, either reapproved or withdrawn. Your comments are invited either for revision of this standard or for additional standards and should be addressed to ASTM International Headquarters. Your comments will receive careful consideration at a meeting of the responsible technical committee, which you may attend. If you feel that your comments have not received a fair hearing you should make your views known to the ASTM Committee on Standards, at the address shown below.*

*This standard is copyrighted by ASTM International, 100 Barr Harbor Drive, PO Box C700, West Conshohocken, PA 19428-2959, United States. Individual reprints (single or multiple copies) of this standard may be obtained by contacting ASTM at the above address or at 610-832-9585 (phone), 610-832-9555 (fax), or service@astm.org (e-mail); or through the ASTM website (www.astm.org).*