



Standard Test Method for Behavior of Materials in a Vertical Tube Furnace at 750°C¹

This standard is issued under the fixed designation E 136; the number immediately following the designation indicates the year of original adoption or, in the case of revision, the year of last revision. A number in parentheses indicates the year of last approval. A superscript epsilon (ϵ) indicates an editorial change since the last revision or reapproval.

This standard has been approved for use by agencies of the Department of Defense.

^{e1} NOTE—An editorial correction was made in July 2000.

1. Scope

1.1 This fire-test-response test method covers the determination under specified laboratory conditions of combustion characteristics of building materials. It is not intended to apply to laminated or coated materials.

1.2 This test method references notes and footnotes that provide explanatory information. These notes and footnotes, excluding those in tables and figures, shall not be considered as requirements of this test method.

1.3 The values stated in SI units are to be regarded as the standard. The values given in parentheses are for information only.

1.4 *This standard is used to measure and describe the response of materials, products, or assemblies to heat and flame under controlled conditions, but does not by itself incorporate all factors required for fire-hazard or fire-risk assessment of the materials, products, or assemblies under actual fire conditions.*

1.5 *This standard does not purport to address all of the safety concerns, if any, associated with its use. It is the responsibility of the user of this standard to establish appropriate safety and health practices and determine the applicability of regulatory limitations prior to use.*

2. Referenced Documents

2.1 ASTM Standards:

D 1929 Test Method for Ignition Properties of Plastics²

D 3174 Test Method for Ash in the Analysis Sample of Coal and Coke from Coal³

E 84 Test Method for Surface Burning Characteristics of Building Materials⁴

E 176 Terminology of Fire Standards⁴

2.2 *ISO Standard:*

ISO 1182 Noncombustibility Test for Building Materials⁵

2.3 *Other Standard:*

BS 476 Combustibility Test of Materials⁵

3. Terminology

3.1 Definitions—For definitions of terms found in this test method, refer to Terminology E 176.

4. Significance and Use

4.1 While actual building fire exposure conditions are not duplicated, this test method will assist in indicating those materials which do not act to aid combustion or add appreciable heat to an ambient fire.

4.2 Materials passing the test are permitted limited flaming and other indications of combustion.

5. Apparatus

5.1 The apparatus, as shown in Fig. 1, shall consist primarily of the following:

5.1.1 *Refractory Tubes*—Two concentric, refractory tubes, 76 and 102 mm (3 and 4 in.) in inside diameter and 210 to 250 mm (8½ to 10 in.) in length, with axes vertical, and with heat applied by electric heating coils outside of the larger tube. A controlled flow of air is admitted tangentially near the top of the annular space between the tubes and passes to the bottom of the inner tube. The outer tube rests on a refractory bottom and the inner tube rests on three spacer blocks so as to afford a total opening under the inner tube equal to or greater than that of the annular space. The refractory bottom plate has a removable plug for cleaning.

5.1.2 *Transparent Cover*—A transparent cover of heat-resistant glass or other transparent material shall be provided over the top of the inner tubes. The cover shall have a circular opening $1\frac{1}{8} \pm \frac{1}{32}$ in. (28.7 ± 0.8 mm) centered over the axis

¹ This test method is under the jurisdiction of ASTM Committee E-5 on Fire Standards and is the direct responsibility of Subcommittee E05.23 on Combustibility.

Current edition approved Oct. 10, 1999. Published January 2000. Originally published as E 136 – 58 T. Last previous edition E 136 – 98^{e1}.

² *Annual Book of ASTM Standards*, Vol 08.01.

³ *Annual Book of ASTM Standards*, Vol 05.05.

⁴ *Annual Book of ASTM Standards*, Vol 04.07.

⁵ Available from American National Standards Institute, 11 W. 42nd St., 13th Floor, New York, NY 10036.

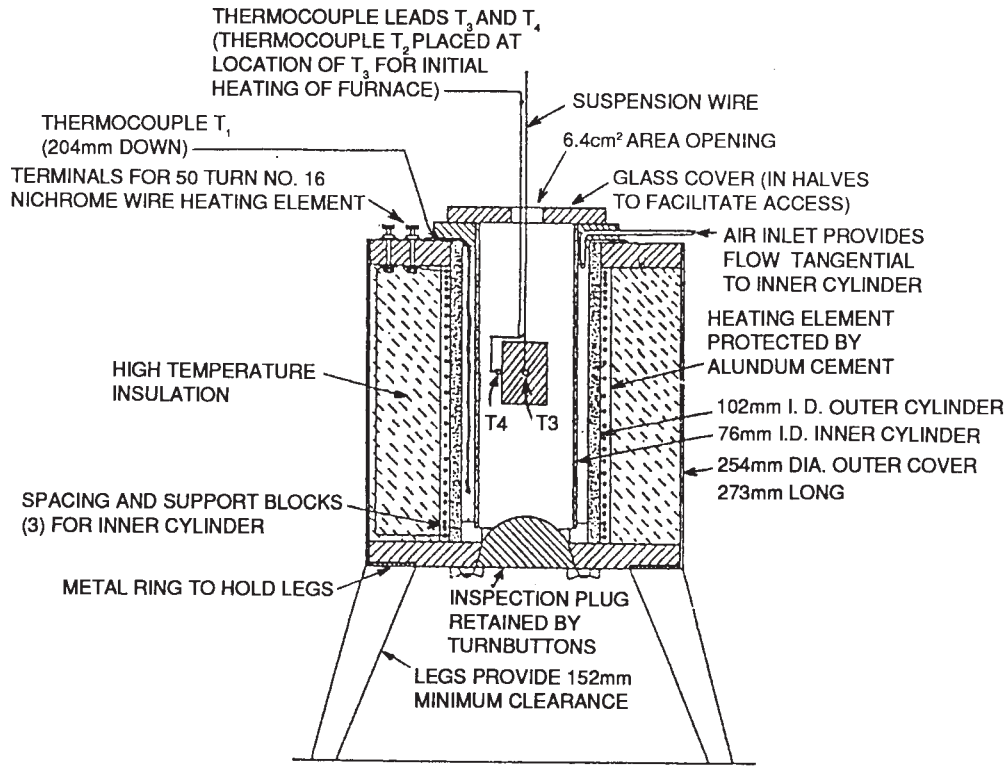

NOTE—Inch-Pound Equivalents

in.	3	4	6	10	10 ³ / ₄	1 in. ²	No. 16 Awg
mm	76	102	152	254	273	6.4 cm ²	1.29

FIG. 1 Cross Section of Furnace Assembly

of the tubes. This opening has an area of 1.0 in.² (645 mm²). The cover shall be in two equally-sized, movable parts.

5.1.3 *Thermocouples* and an automatically recording device shall be provided. The thermocouples shall be located as follows:

5.1.3.1 Thermocouple T_1 is located in the center of the air space between the two concentric, refractory tubes; approximately 204 mm (8 in.) down from the top of the 102-mm (4-in.) diameter tube (Note 1).

5.1.3.2 Thermocouple T_3 is located at the approximate geometric center of the specimen.

5.1.3.3 Thermocouple T_4 is located on the surface, in contact with the specimen; in the same horizontal plane as T_3 .

5.1.3.4 Thermocouples T_1 , T_3 and T_4 shall have a time constant (time to reach 63.2 % of the furnace air temperature of 750°C (1382°F)) of 5 to 10 s (Note 2).

NOTE 1—Thermocouple T_1 is used for better regulation of the temperature of the air in the furnace space.

NOTE 2—Ungrounded, metallic-sheathed thermocouples of 1-mm diameter have been found to meet the time constant requirements.

5.2 *Specimen Holder*—The specimen holder for solid specimens shall be as shown in Fig. 2.

5.2.1 Specimens in granular or powder form shall be contained in thin-wall, open-top vessels of inert materials whose

outside dimensions conform to the specimen shape and maximum size specified in 6.1. These vessels shall have walls of either solid or mesh construction.

5.3 *Specimen Location*—During the test, the geometric center of the specimen shall be located at the geometric center ± 3 mm ($\pm 1/8$ in.) of the 76-mm (3-in.) diameter tube.

6. Test Specimens

6.1 All test specimens shall be 38 by 38 by 51 \pm 2.5 mm (1.5 by 1.5 by 2.0 \pm 0.1 in.). The specimens shall be dried at 60 \pm 3°C (140 \pm 5°F) for not less than 24 h but no more than 48 h. Specimens shall then be placed in a desiccator to cool at least 1 h before testing.

6.2 Not less than four identical specimens shall be tested.

7. Procedure

7.1 Furnace Preparation:

7.1.1 Conduct the test at room conditions of 21 \pm 3°C (70 \pm 5°F).

7.1.2 *Air Flow*—Provide an external air source to supply clean air through a metal tube located near the furnace top, tangentially between the annular spaced ceramic tubes. The air shall be supplied at a steady and controllable rate of 0.0027 m³/min (0.10 ft³/min) \pm 20 %, which will give an air flow of

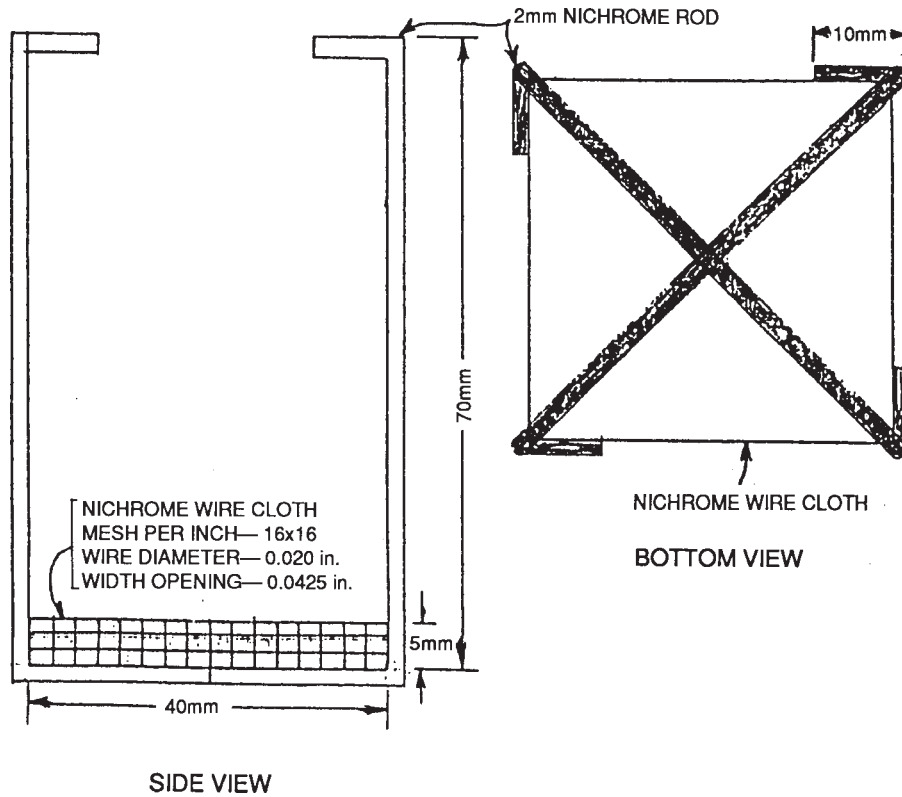

FIG. 2 Specimen Holder for Solid Specimens

3 m (10 ft)/min past a loaded specimen in the furnace at 750°C (1382°F). Measure the air at room temperature, as specified in 7.1.1 and meter by a rotameter or other metering device in line with the metal tube.

7.1.3 Prepare the furnace by bringing the temperature of thermocouple T_2 (Note 3), located in the furnace at the position to be occupied by the geometric center of the specimen, to a temperature of $750 \pm 5.5^\circ\text{C}$ ($1382 \pm 10^\circ\text{F}$). Maintain the temperature in the unloaded furnace for at least 15 min to assure stability.

NOTE 3—The temperature T_2 is measured by means of a thermocouple inserted from the top during the initial heating period. Once the operating temperature has been established by thermocouple T_2 , note the temperature on thermocouple T_1 and control the test chamber during the test to the observed T_1 temperature reading. T_3 may be used as T_2 .

7.2 As rapidly as possible, insert the test specimen into the furnace with thermocouple T_3 inserted from the top of the specimen to its approximate geometric center and thermocouple T_4 attached to the side surface of the specimen. Close the top cover to the 6.4-cm² (1-in.²) opening immediately after insertion of the specimen. Readings for thermocouples T_3 and T_4 shall be made at intervals (Note 4) not to exceed 10 s during the first 5 min, and as often as necessary afterwards to produce a smooth curve. Do not change the regulation of the current through the heating coils and the air flow during the test.

NOTE 4—A continuous read-out recording is preferred since it is possible for the maximum temperature to occur between the 10-s intervals.

7.3 Continue the test until the temperatures at thermocouples T_3 and T_4 have reached maxima, or until it is clearly evident that the specimen does not pass this test.

7.4 Throughout the test make and record visual observations on the specimens, noting quality, quantity, or intensity and duration of flaming or smoking, or both, and change of state.

7.5 Weigh each specimen before and after testing and record the weight loss to the nearest 1 %.

8. Report

8.1 Report the material as passing the test if at least three of the four specimens tested meet the individual specimen criteria detailed in 8.2 or 8.3. The three specimens do not need to meet the same condition.

8.2 When the weight loss of the specimen is 50 % or less:

8.2.1 The recorded temperatures of the surface and interior thermocouples do not at anytime during the test rise more than 30°C (54°F) above the stabilized temperature measured at T_2 prior to the test.

8.2.2 There is no flaming from the specimen after the first 30 s.

8.3 When the weight loss of the specimen exceeds 50%:

8.3.1 The recorded temperature of the surface and interior thermocouples do not at anytime during the test rise above the stabilized temperature measured at T_2 prior to the test.

8.3.2 There is no flaming from the specimen at any time during the test.

9. Precision and Bias

9.1 No information is presented about the precision and bias of this test method for measuring combustion characteristics since the test results are nonquantitative. (See X1.7.)

10. Keywords

10.1 building materials; combustion; heated tube; limited combustion; Setchkin furnace; vertical tube furnace

APPENDIX

(Nonmandatory Information)

X1. COMMENTARY

X1.1 Introduction

X1.1.1 The difference in fire risk between a combustible building material and a noncombustible (or incombustible) one is generally obvious. However, some materials may contain only a limited amount of combustible content and may not contribute appreciably to an ambient fire. The term noncombustible, while in recognized use as indicating a material that will not ignite or burn, is indefinite in its application unless referenced to a well defined testing procedure.

X1.2 Definition

X1.2.1 Most dictionaries have defined noncombustible in simple terms, such as that used in the 1920 edition of the National Building Code promulgated by the National Board of Fire Underwriters (NBFU): Incombustible materials or construction are those that “will not ignite or burn when subjected to fire.” In 1943 the same code redefined incombustible construction as “assemblies which do not involve materials of such kind or quantity or so contained as to burn during exposure in a test fire or continue flaming or ignite after the furnace is shut off.”

X1.2.2 About this same time Committee C-5 (now E-5) and the New York City Building Code suggested adding a reference of 649°C (1200°F) as the fire exposure temperature. By 1949 the term incombustible was changed to noncombustible in the National Building Code without definition. The first edition of the BOCA Basic Building Code (1950) defined a noncombustible material as “any material which will neither ignite or actively support combustion in air at a temperature of 649°C (1200°F) during an exposure of five minutes in a vented tube or vented crucible furnace.”

X1.2.3 The 1955 edition of the NBFU National Building Code established a definition for noncombustible material **(1)**⁶ that was subsequently adopted by other model codes, the Life Safety Code **(2)**, and most local codes. The adopted definition was as follows:

Noncombustible as applied to a building construction material means a material that, in the form in which it is used, falls in one of the following groups (a) through (c). It does not apply to surface finish materials nor to the determination of whether a material is noncombustible from the standpoint of clearances to heating appliances, flues or other sources of high tempera-

ture. No material shall be classed as noncombustible which is subject to increase in combustibility or flame spread rating beyond the limits herein established, through the effects of age, moisture or other atmospheric condition. Flame spread rating as used herein refers to ratings obtained in accordance with Test Method E 84.

a) Materials no part of which will ignite and burn when subjected to fire. Any material that liberates flammable gas when heated to a temperature of 750°C (1382°F), for 5 min shall not be considered noncombustible within the meaning of this paragraph.

b) Materials having a structural base of noncombustible material, as defined in (a), with a surfacing not over 1/8-in. thick that has a flame spread rating not higher than 50.

c) Materials, other than as described in (a) or (b), having a surface flame spread rating not higher than 25 without evidence of continued progressive combustion and of such composition that surfaces that would be exposed by cutting through the material in any way would not have a flame spread rating higher than 25 without evidence of continued progressive combustion.

X1.2.4 In adopting this definition, NBFU stated that it was based on a determination of which materials “could be properly classed as noncombustible and then fixing the qualifying conditions in the definition to include these materials.” The definition was considered to apply to materials used for the walls, roofs, or other structural parts of buildings, but not to surface finish materials and not to the determination of whether a material is noncombustible from the standpoint of clearances to heating appliances, flues, or other sources of high temperature.

X1.2.5 After Test Method E 136 was promulgated, (initially as a tentative in 1958, then as a full standard in 1965), many building codes replaced either part (a) of the NBFU definition or the entire definition with the specification that materials shall have been successfully tested in accordance with Test Method E 136. In 1973, the American Insurance Association (successor to NBFU) introduced a definition of a limited-combustible material and redefined a noncombustible material as one that, in the form in which it is used and under the conditions anticipated, will not ignite, burn, support combustion, or release flammable vapors, when subjected to fire or heat.

X1.2.6 To avoid misinterpretation in the use of the term noncombustible, Committee E-5 has decided to limit the use of this term, and it was eliminated from the title and text of Test

⁶ The boldface numbers in parentheses refer to the list of references appended to this method.

Method E 136 in 1979. The current title provides a more specific description of the restricted nature of the test method.

X1.3 Origin and Early History of Test Method E 136

X1.3.1 In 1912 R. E. Prince developed a furnace apparatus to study the ignitability of various wood species and investigate the effect of fire-retardant chemical treatments on their ignition characteristics (3, 4). This apparatus as shown in Fig. X1.1 consisted essentially of a quartz cylinder 76 mm (3 in.) in diameter and 254 mm (10 in.) long, which was wound with a high electrical resistance nichrome ribbon. The cylinder was heavily insulated with asbestos. A lower chamber of about 89 mm (3.5 in.) in diameter and 203 mm (8 in.) deep formed a continuation of the upper chamber. A natural draft was used. No attempt was made to control the temperature or humidity of the air passing through the apparatus. The test temperature was 200°C (392°F). The 32 by 32 by 102-mm (1¼ by 1¼ by 4-in.) specimen was first weighted and then lowered in the hot quartz cylinder where it remained until it ignited or for 40 min. Ignition time, if it occurred, was recorded and the specimen was then moved into the lower cooler chamber and allowed to burn for not more than 3 min. Loss of weight was then determined. Intensity of burning was also recorded.

X1.3.2 An apparatus quite similar to the Prince-FPL apparatus was later adopted as part of the British Standard 476-1932. In a revision of BS 476 in 1953, the test was renamed, and the furnace was preheated and maintained at 750°C (1382°F) prior to introduction of the specimen. This test specified that a material shall be considered combustible if,

during the 15-min test period, any one of six specimens was observed to flame, to produce vapors that were ignited by a pilot flame, or to cause the temperature of the furnace to increase 50°C or more above 750°C (1382°F). In a report dated April 11, 1945, Dr. S. H. Ingberg suggested to Committee C-5 (now E-5) a method of test quite similar to the British test. The apparatus is shown in Fig. X1.2. A paper describing the test was published in the ASTM proceedings (5, 6). The method differed from the British test by having the insulation enclosure round instead of square and employed a constant temperature of 750°C (1382°F) instead of a graduated temperature. Specimen size was 50 by 38 mm (2 by 1½ in.) by *T* where *T* equals the normal thickness or a maximum of 38 mm (1½ in.).

X1.3.3 A variation of the 1945 proposed apparatus and a method for determining the ignition temperature of plastics under well controlled conditions was reported by N. P. Setchkin in December 1949 (7). This apparatus is shown in Fig. X1.3. This test was subsequently adopted by Committee D-20 as Test Method D 1929.⁷ Major changes included elimination of the lower chamber, the provision of two concentric refractory cylinders and a controlled air flow directed between the cylinders, and the location of thermocouples.

X1.3.4 At the request of Subcommittee V (Nomenclature and Definitions) of Committee E-5, tests on 47 specimens of solid materials were made in 1952 at the National Bureau of Standards (NBS), the National Research Council of Canada,

⁷ Published as Test Method D 1929 – 62 T, that is, a tentative standard.

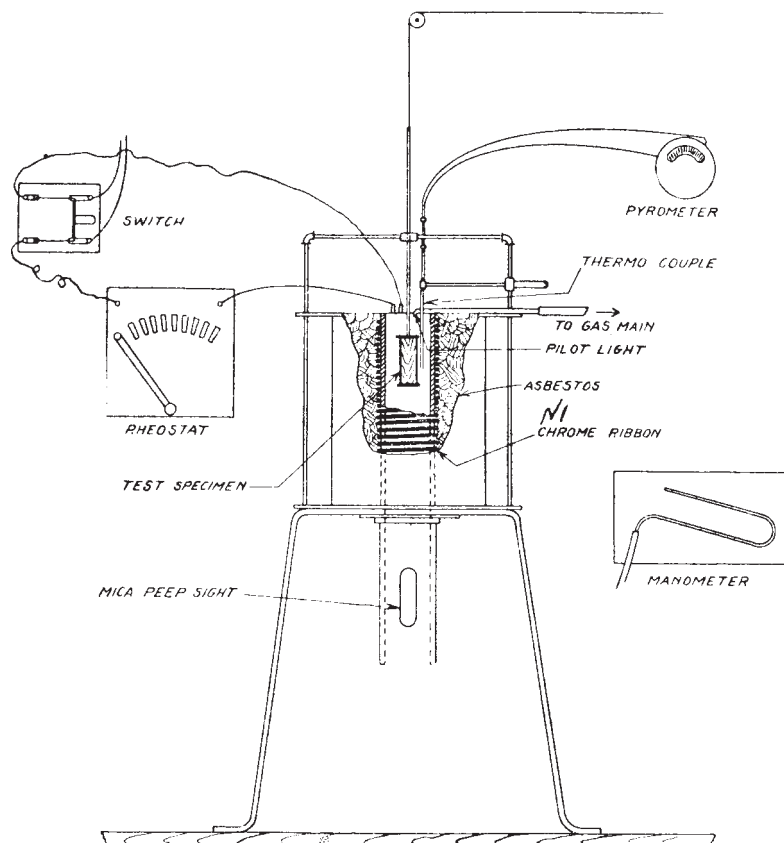

FIG. X1.1 Inflammability Apparatus No. 1

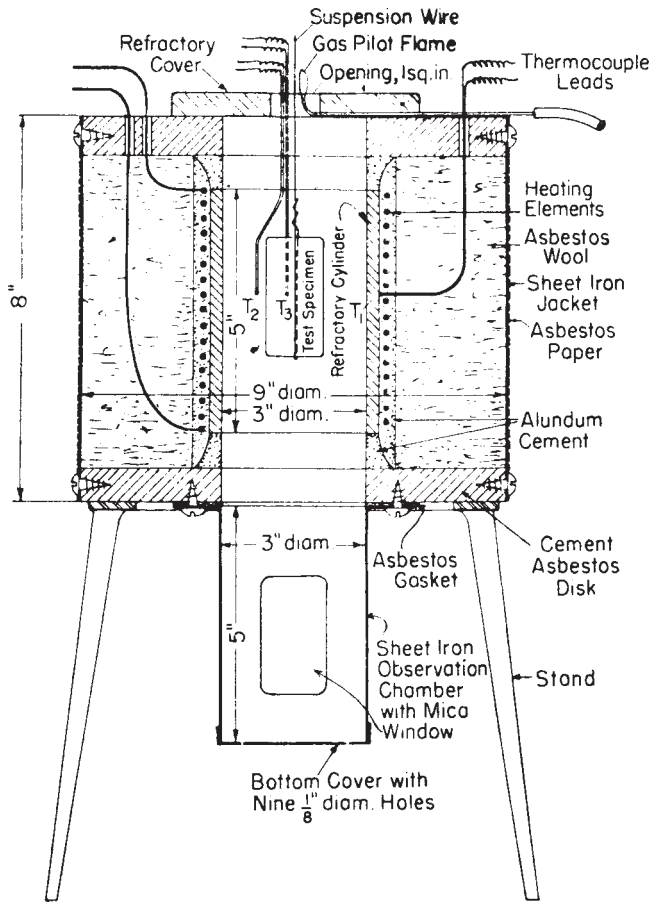
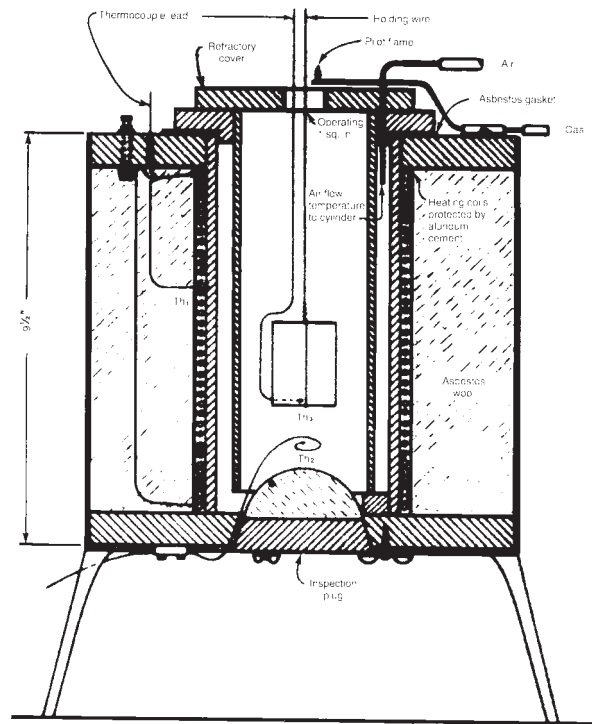

FIG. X1.2 Apparatus for Incombustibility Tests



NOTE—

Legend:
 Th_1 —Thermocouple on outer wall
 Th_2 —Thermocouple in air stream
 Th_3 —Thermocouple in or on the specimen

FIG. X1.3 Ignition Apparatus for Solids

The Ohio State University, Southwest Research Institute, and Owens-Corning Laboratories for the purpose of evaluating a technique for determining the combustibility classifications of solid materials (8, 9). Professor Shank, at The Ohio State University, continued work on the test method. Through his efforts publication of a revised draft of the proposed test in the *ASTM Bulletin* was authorized at the February 8, 1957, meeting of Committee E-5. Publication was for information purposes and comment (10).

X1.3.5 It was reported at the February 12, 1958, meeting of Committee E-5 that no comments or criticisms had been received on the test method; a motion to publish it as a tentative test method was carried (11). The apparatus described in Tentative Standard Method of Test for Defining Noncombustibility of Building Materials⁸ was as shown in Fig. X1.4. Committee E-5 voted for retention of the standard following its October 1963 meeting and at the same meeting voted to advance Test Method E 136 to full standard that was published in 1965.⁹ Additional changes, described in X1.5 through X1.8, were incorporated in the 1973 and 1979 revisions of the test method.

⁸ This test method was approved June 22, 1958, and published as E 136 – 58 T, that is, a tentative standard.

⁹ Method of Test E 136 – 65, Determining Noncombustibility of Elementary Materials.

X1.4 Other Test Methods

X1.4.1 At the request of the U.S. Coast Guard (June 3, 1970), a test program at the NBS was coordinated by a task subgroup of Subcommittee E05.05 to evaluate two principal tests used to determine combustibility: Test Method E 136 and ISO R 1182 (12). A modification of ISO 1182 was adopted in 1973 by the Intergovernmental Maritime Consultative Organization (IMCO), an agency of the United Nations, for qualifying marine materials as noncombustible. This test is designated Resolution A270 (VIII) and incorporates changes in equipment details plus requirements for approval as noncombustible materials; in this test method, the average duration of flaming is limited to 10 s. This test method was adopted in 1976 as the U.S. Coast Guard test for approval of noncombustible materials for merchant vessels. ISO R 1182-1970 was superseded by ISO 1182-1979 using the apparatus shown in Fig. X1.5. The current version contains improved test method and equipment details and recognition of mass loss for low density polymeric materials. Furthermore, materials are no longer classified as noncombustible; instead, the following (average) test results are reported: (1) maximum readings of the furnace, surface, and center thermocouples; (2) duration of sustained flaming; and (3) mass loss. The annex in ISO R 1182 provides “suggested criteria for evaluation: not more than 50°C rise; not more than 20 s flaming; and not more than 50 % mass loss.”

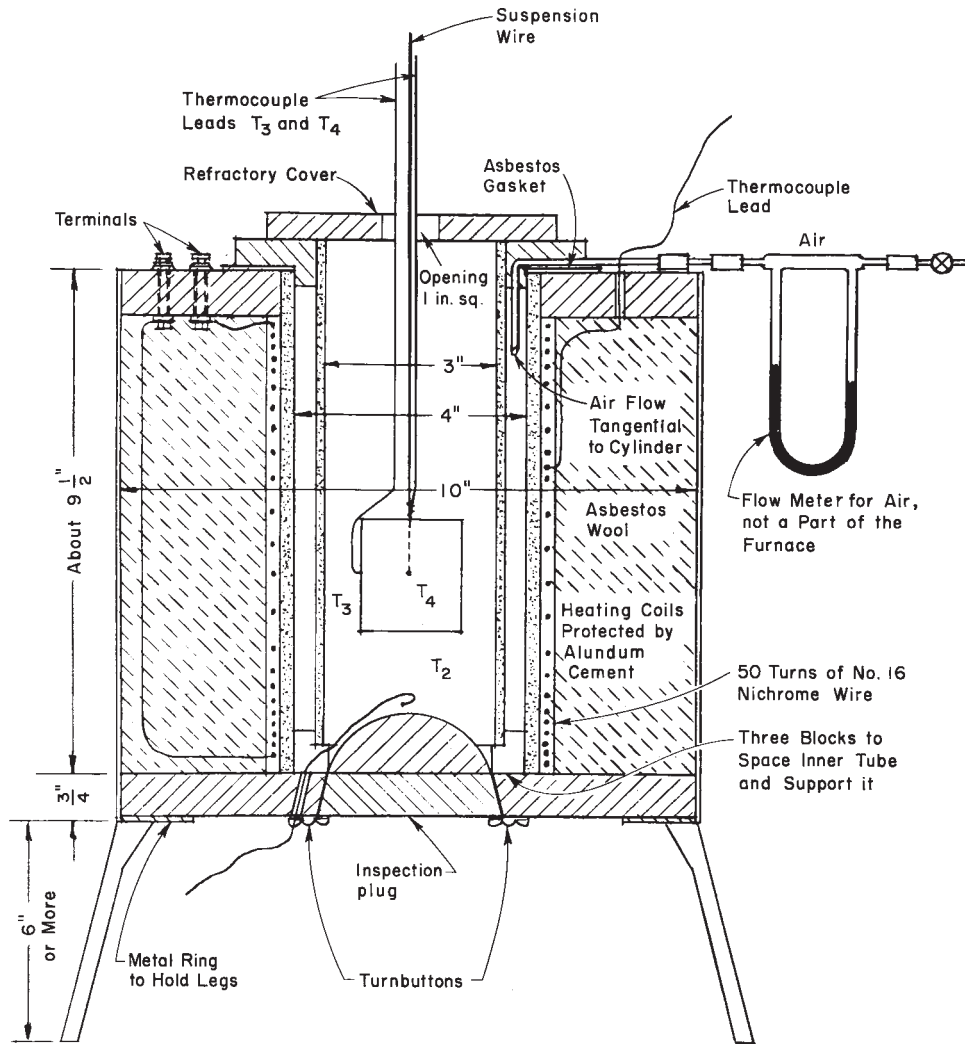

FIG. X1.4 Cross Section of Furnace Assembly

X1.5 Rationale for Test Method E 136 Criteria

X1.5.1 The choice of the 750°C (1382°F) furnace temperature derives basically from the BS 476 temperature limit. To some extent, it also represents the upper limit of temperatures quoted in early code definitions of noncombustible materials. It is a temperature that is representative of levels that are known to exist during building fires, although temperatures from 1000 to 1200°C (1800 to 2200°F) are attained in intense fires. It is also used for determining the ash content of coal (Test Method D 3174) although loss on ignition tests are commonly conducted at 900 to 1000°C (1600 to 1800°F). For many building materials, complete burning of the combustible fraction will occur as readily at 750°C (1382°F) as at 900 to 1000°C (1600 to 1800°F).

X1.5.1.1 The need to measure and to limit the duration of flaming and the rise in temperature arose since a brief period of flaming and a small amount of self heating were not considered serious limitations to the use of building materials which would otherwise be acceptable. Based on a series of tests on a wide variety of materials (9), a 30-s flame duration and a 30°C (54°F) rise were proposed as two criteria that could help to distinguish between clearly combustible and clearly noncom-

bustible materials. The results of these tests indicated that the proposed levels would limit the combustible portion of noncombustible materials to a maximum of 3%. It was further suggested that the fire hazard characteristics of materials of uncertain classification should be determined in large-scale tests.

X1.5.2 The need to test at least four identical specimens was acknowledged in the initial 1957 proposal that specified that the results of tests should be averaged (10). In 1958 (or 1959), the test method was written to require that the criteria apply to "three or more of the four specimens tested," possibly to recognize the variable nature of the measurement and the fact that there were difficulties in observing the presence and duration of flaming.

X1.5.3 The 50% weight loss limitation (7.1.3) is provided to preclude the possibility that combustion of low density materials will occur so rapidly that the recorded temperature rise and the measured flaming duration will be less than the prescribed limits. The choice of 50% was considered desirable for materials that contain appreciable quantities of combined water (or gaseous components).

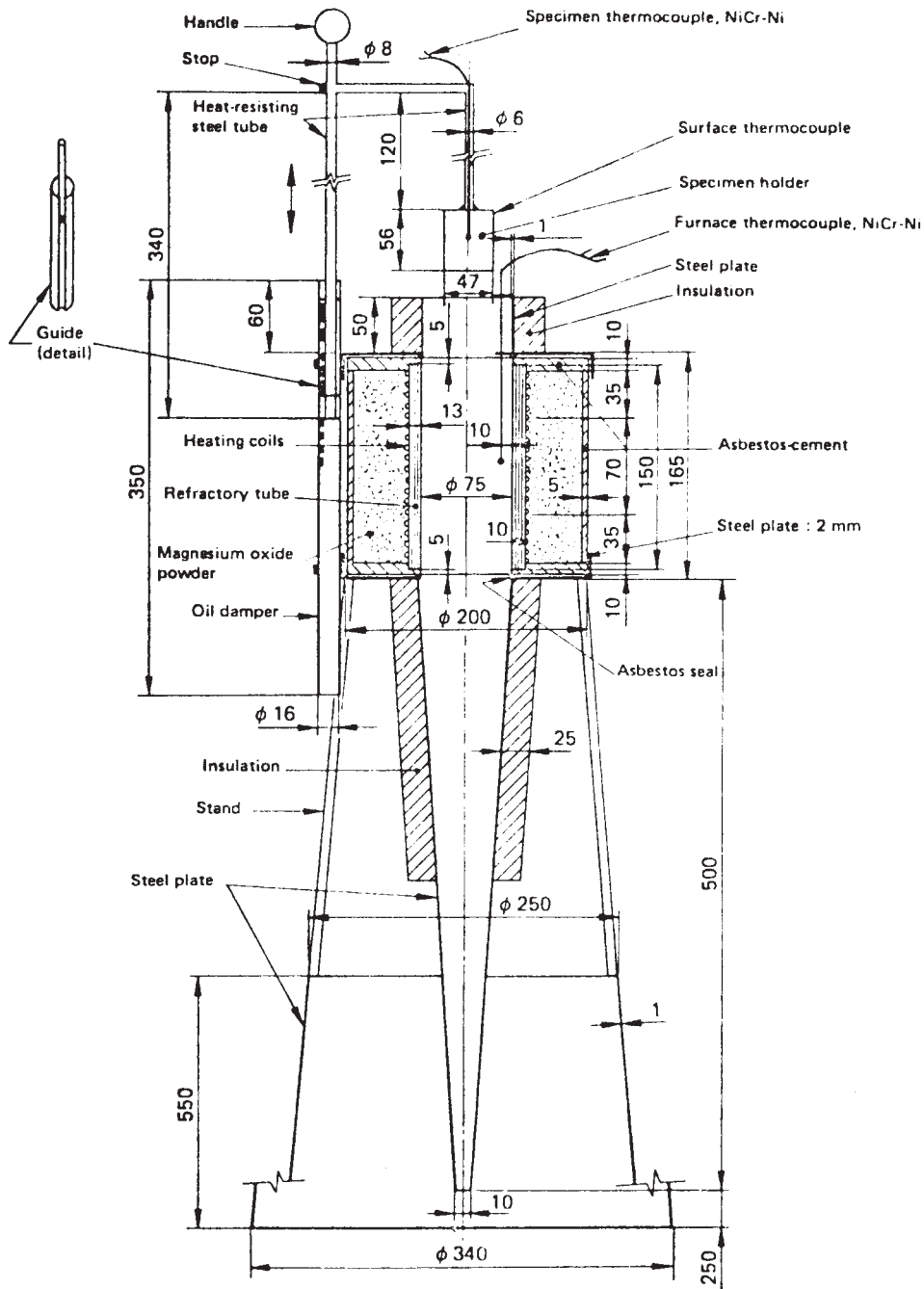

FIG. X1.5 Noncombustibility test apparatus—General arrangement

X1.5.4 It appears that the scope limitations to elementary materials (through the 1973 edition) and the exclusion of laminated and coated materials reflected the uncertainties associated with more complex materials and with products that could not be tested in a realistic configuration.

X1.6 Test Limitations

X1.6.1 At present, there are a number of limitations in the test method and its application that should be recognized.

Materials are not necessarily tested in the nature and form used in most building applications. The test sample consists of a small, specified volume that is either (1) cut from a thick sheet; (2) assembled from multiple thicknesses of thin sheets; or (3) placed in a container if composed of granular powder or loose fiber materials.

X1.6.2 The test method does not provide a measure of an intrinsic property. Test results apply to the specific test apparatus and test conditions and would be expected to vary with

(1) the size, shape, and arrangement of the specimen; (2) the distribution of organic content; (3) the exposure temperature; (4) the air supply; (5) the location of thermocouples, etc.

X1.6.2 The test method does not provide a quantitative measure of heat generation or combustibility; it simply serves as a test method with selected (end point) measures of limited combustibility.

X1.6.3 The test method is not suitable or generally satisfactory for materials that soften, flow, melt, or otherwise separate from the measuring thermocouple.

X1.6.4 The test method does not measure the self-heating tendencies of large masses of materials. For example, it provides no indication of potential self-heating of resin-impregnated mineral fiber insulation or oil-coated metal products.

X1.7 Precision, Bias, and Sensitivity

X1.7.1 This test method does not contain a numeric precision and bias statement because the reported results are recorded as pass or fail.

X1.7.2 There have been attempts to determine precision and bias for this method. Two series of interlaboratory tests have been conducted according to previous versions of this test method. In 1947, twelve years prior to the initial adoption of Test Method E 136, a total of 47 solid materials were provided for testing by seven laboratories, but no summary report or conclusions on interlaboratory reproducibility appear to have been developed.

X1.7.3 In 1963, several laboratories participated in a limited round robin involving 13 materials and two test methods, E 136 – 73 and ISO R 1182. Results from three laboratories that provided data for Test Method E 136 were compared in terms of the surface temperature rise and in terms of the classification of combustible or noncombustible (12). The variation in peak surface temperature rise typically ranged from 15 to 20°C (27 to 36°F) for temperature rises near the limiting value, for example, 30 ± 20°C (54 ± 36°F) rise. In terms of classification, the three laboratories agreed on a noncombustible classification for four materials and on a combustible classification for eight materials (although not necessarily by the same criteria). One material was classified combustible by one laboratory and noncombustible by two laboratories. However, agreement would probably have been attained if the tests had not been terminated prematurely. No known sensitivity studies have been conducted on Test Method E 136, although one laboratory did perform a sensitivity study in 1973 on ISO R 1182 and concluded that the peak surface temperature rise was not sensitive to the prescribed change in furnace temperature level 730°C versus 750°C or in specimen location (mid-height of furnace versus 20 mm (¾ in.) below mid-height).

X1.8 Recent Considerations

X1.8.1 In addition to the inclusion of the weight loss limitation, the 1973 edition of the test method also included the response characteristics of the measuring thermocouples T_3 and T_4 in terms of a specified time constant. The mandatory caveat established by the ASTM Board of Directors was added

editorially in July 1974. During the last few years, there was some support for eliminating the pass-fail feature of the test on the basis that the selection of limit values was arbitrary and that these should properly be set by the building officials using the test method. While physical, thermal, and flammability properties are commonly included in specifications, such endpoints are not normally included in ASTM test methods, except as a means for separating materials into classes or types. However it was also held that the inclusion of a single set of commonly accepted limit values would avoid a possible proliferation of endpoints in different codes and standards.

X1.8.2 A change that has generated controversy is the elimination of the previous restriction to elementary materials and the retention of the exclusion of laminated and coated materials. At the present time, a task group is considering an alternative method of testing laminated and coated materials.

X1.8.2.1 The major changes from E 136 – 73 to E 136 – 79 are (a) change in title; (b) removal of elementary from the scope; (c) addition of Significance and Use section; and (d) replacement of the Interpretation of Results section containing the phrase “. . . shall be reported as noncombustible if . . .” with a Report section containing the phrase “Report the material as passing the test if . . .” (13).

X1.8.3 During the December 1979 meeting of Committee E-5, a question was raised about the length of the ceramic tubes in the Test Method E 136 furnace specified to be 254 mm (10 in.) long (outside cover 273 mm (10¾ in.)). A survey was made of Committee E-5 members in January 1980 concerning experience with and impact of size of tube on test results. A successful ballot to revise the size of the refractory tubes was accepted at the December 1980 meeting of the committee. The revision is as currently stated in 5.1.1.

X1.8.4 In 1980 a proposal was made to substitute the furnace employed in ISO 1182 for the furnace used in Test Method E 136 but to retain all other details of the test method. This proposal was not accepted.

X1.8.5 Additional information can provide comparisons of Test Method E 136, ISO 1182, and the IMCO (modified ISO) test methods (14–20). Questions concerning Test Method E 136 should be addressed to Subcommittee E05.23 of Committee E-5 on Fire Standards.

X1.8.6 In 1992, Subcommittee E05.23 approved an addition to this test method in order to provide a value for the volume air flow rate through the test furnace, in addition to the linear air flow rate that had been listed since the creation of the standard. The volume flow, which is derived from the linear flow, is the value actually used to monitor the air flow rate during testing. The value for volume flow rate in the 1993 and 1994 versions of this test method was incorrect. This value assumed that the linear flow rate (3.0 m/min) was at room temperature (approximately 21°C), rather than at the elevated furnace temperature 750°C. The difference in the two calculations for the volume flow rate is approximately a factor of three (correct calculation, 0.00267 m³/min; incorrect calculation, 0.00927 m³/min). It was not the intent of the task group or subcommittee to change the test method, which was based on linear air flow rate.

REFERENCES

- (1) "Definition of Noncombustible Building Construction Material," *Special Interest Bulletin No. 294*, revised August 1967, American Insurance Assn., New York, NY.
- (2) "Life Safety Code," *NFPA 101*, National Fire Protection Assn., Quincy, MA 1976.
- (3) Eickner, H. W., "Fire Research at the U.S. Forest Products Laboratory," Approved Technical Article, *Fire Research Abs. and Rev.*, National Academy of Science and National Research Council, Vol 6, No. 1, 1964 Washington, D.C.
- (4) Prince, R. E., "Tests on the Inflammability of Untreated Wood and Wood Treated with Fire-Retarding Compounds," *NFPA Proceedings*, 1915, pp. 108–112.
- (5) Setchkin, N. P. and Ingberg, S. H., "Test Criterion for an Incombustible Material," *Proceedings of the American Society for Testing Materials*, Philadelphia, PA, Vol 45, 1945.
- (6) Ingberg, S. H., Notes on E 136 – 59 T and Requirements for Incombustibility, 11 pp. Minutes of ASTM Committee E-5, October 13, 1964 and January 15, 1965 (copy at ASTM Headquarters).
- (7) Setchkin, N. P., "A Method and Apparatus for Determining the Ignition Characteristics of Plastics," *Research Paper RP 2052*, *Journal of Research*, National Bureau of Standards Vol 43, December 1949, pp. 591–608.
- (8) Sumi, K., *Comparison of Combustibility Test Procedures*, Report No. 43, Division of Building Research, National Research Council of Canada, Ottawa, Ont., July 1955.
- (9) Setchkin, N. P., *Combustibility Tests of 47 ASTM Material Samples* National Bureau of Standards (NBS) Project 1002-43-1029, Report No. 1454, Feb. 6, 1952, Washington, D.C.
- (10) "Proposed Method of Test for Defining Noncombustibility of Building Materials," *ASTM Bulletin*, February 1957. pp. 33–34.
- (11) Yuill, C. H., "Fire Terms and Fire Tests," *Materials Research and Standards*, Vol 10, No. 10. American Society for Testing and Materials, 1970, pp. 24–26.
- (12) Gross, D., Lindauer, R. A., and Willard, R., "Evaluation of Two Test Methods for Noncombustibility: ASTM E 136 and ISO R1182," Unpublished NBS Report, 1973.
- (13) Explanation accompanying ballot on ASTM Test Method E 136, Item 4, January 1978.
- (14) Loftus, J. J., "Noncombustibility of Mineral Wood and Glass Fiber Insulation Materials," *NBS Report 9988*, Feb. 3, 1969.
- (15) Benjamin, I. A., "ISO Noncombustibility Furnace," *NBS Report 10330*, Aug. 28, 1970.
- (16) Gross, D. and Benjamin, I. A., "Evaluation of ISO Furnace Test for Noncombustibility," Unpublished NBS Report, March 15, 1971.
- (17) McDaniel, D. E., "Noncombustibility: A Marine View," *Ignition, Heat Release, and Noncombustibility of Materials*, *ASTM STP 502*, Am. Soc. Testing Mats., 1971.
- (18) Herpol, G. A., "Noncombustibility—Its Definition, Measurement, and Applications," *Ignition, Heat Release, and Noncombustibility of Materials*, *STP 502*, Am. Soc. Testing Mats., 1971.
- (19) Loftus, J. J. and Robertson, A. F., *Experiments with A Proposed Test Procedure for Noncombustible Materials*, *NBS Report 9529*, May 4, 1967.
- (20) *Report of Test on Five Asbestos Type Insulation Boards for United States Coast Guard—Report No. TG10210-2183: FR 3720*. U.S. National Bureau of Standards.

The American Society for Testing and Materials takes no position respecting the validity of any patent rights asserted in connection with any item mentioned in this standard. Users of this standard are expressly advised that determination of the validity of any such patent rights, and the risk of infringement of such rights, are entirely their own responsibility.

This standard is subject to revision at any time by the responsible technical committee and must be reviewed every five years and if not revised, either reapproved or withdrawn. Your comments are invited either for revision of this standard or for additional standards and should be addressed to ASTM Headquarters. Your comments will receive careful consideration at a meeting of the responsible technical committee, which you may attend. If you feel that your comments have not received a fair hearing you should make your views known to the ASTM Committee on Standards, at the address shown below.

This standard is copyrighted by ASTM, 100 Barr Harbor Drive, PO Box C700, West Conshohocken, PA 19428-2959, United States. Individual reprints (single or multiple copies) of this standard may be obtained by contacting ASTM at the above address or at 610-832-9585 (phone), 610-832-9555 (fax), or service@astm.org (e-mail); or through the ASTM website (www.astm.org).