



## Standard Test Method for Determination of Fire and Thermal Parameters of Materials, Products, and Systems Using an Intermediate Scale Calorimeter (ICAL)<sup>1</sup>

This standard is issued under the fixed designation E 1623; the number immediately following the designation indicates the year of original adoption or, in the case of revision, the year of last revision. A number in parentheses indicates the year of last reapproval. A superscript epsilon ( $\epsilon$ ) indicates an editorial change since the last revision or reapproval.

### 1. Scope

1.1 This fire-test-response standard assesses the response of materials, products, and assemblies to controlled levels of radiant heat exposure with or without an external ignitor.

1.2 The fire-test-response characteristics determined by this test method include the ignitability, heat release rates, mass loss rates, visible smoke development, and gas release of materials, products, and assemblies under well ventilated conditions.

1.3 This test method is also suitable for determining many of the parameters or values needed as input for computer fire models. Examples of these values include effective heat of combustion, surface temperature, ignition temperature, and emissivity.

1.4 This test method is also intended to provide information about other fire parameters such as thermal conductivity, specific heat, radiative and convective heat transfer coefficients, flame radiation factor, air entrainment rates, flame temperatures, minimum surface temperatures for upward and downward flame spread, heat of gasification, nondimensional heat of gasification ( $1$ )<sup>2</sup> and the  $\Phi$  flame spread parameter (see Test Method E 1321). While some studies have indicated that this test method is suitable for determining these fire parameters, insufficient testing and research have been done to justify inclusion of the corresponding testing and calculating procedures.

1.5 The heat release rate is determined by the principle of oxygen consumption calorimetry, via measurement of the oxygen consumption as determined by the oxygen concentration and flow rate in the exhaust product stream (exhaust duct). The procedure is specified in 11.1. Smoke development is quantified by measuring the obscuration of light by the combustion product stream (exhaust duct).

1.6 Specimens are exposed to a constant heating flux in the range of 0 to 50 kW/m<sup>2</sup> in a vertical orientation. Hot wires are

used to ignite the combustible vapors from the specimen during the ignition and heat release tests. The assessment of the parameters associated with flame spread requires the use of line burners instead of hot wire ignitors.

1.6.1 Heat release measurements at low heat flux levels (< 10 kW/m<sup>2</sup>) require special considerations as described in Section A1.1.6.

1.7 This test method has been developed for evaluations, design, or research and development of materials, products, or assemblies, for mathematical fire modeling, or for research and development. The specimen shall be tested in thicknesses and configurations representative of actual end product or system uses.

1.8 Limitations of the test method are listed in Section 5.5.

1.9 The values stated in SI units are to be regarded as the standard.

1.10 *This standard is used to measure and describe the response of materials, products, or assemblies to heat and flame under controlled conditions, but does not by itself incorporate all factors required for fire hazard or fire risk assessment of the materials, products, or assemblies under actual fire conditions.*

1.11 *Fire testing of products and materials is inherently hazardous, and adequate safeguards for personnel and property shall be employed in conducting these tests. This test method may involve hazardous materials, operations, and equipment. Specific information about hazard is given in Section 7.*

1.12 *This standard does not purport to address all of the safety concerns, if any, associated with its use. It is the responsibility of the user of this standard to establish appropriate safety and health practices and determine the applicability of regulatory limitations prior to use.*

### 2. Referenced Documents

#### 2.1 ASTM Standards:

D 2016 Test Methods for Moisture Content of Wood<sup>3</sup>

D 3286 Test Method for Gross Calorific Value of Coal and

<sup>1</sup> This test method is under the jurisdiction of ASTM Committee E05 on Fire Standards and is the direct responsibility of Subcommittee E05.21 on Smoke and Combustion Products.

Current edition approved Jan. 10, 2002. Published April 2002. Originally published as E 1623 – 94. Last previous edition E 1623 - 99<sup>ε1</sup>.

<sup>2</sup> The boldface numbers given in parentheses refer to the list of references at the end of this standard.

<sup>3</sup> Discontinued; see 1988 Annual Book of ASTM Standards, Vol 04.09. Replaced by D 4442 and D 4444.

- Coke by the Isoperibol Bomb Calorimeter<sup>4</sup>
- E 84 Test Method for Surface Burning Characteristics of Building Materials<sup>5</sup>
- E 176 Terminology of Fire Standards<sup>5</sup>
- E 177 Practice for Use of the Terms Precision and Bias in ASTM Test Methods<sup>6</sup>
- E 662 Test Method for Specific Optical Density of Smoke Generated by Solid Materials<sup>5</sup>
- E 691 Practice for Conducting an Interlaboratory Study to Determine the Precision of a Test Method<sup>6</sup>
- E 800 Guide for Measurement of Gases Present or Generated During Fires<sup>5</sup>
- E 906 Test Method for Heat and Visible Smoke Release Rates for Materials and Products<sup>5</sup>
- E 1321 Test Method for Determining Material Ignition and Flame Spread Properties<sup>5</sup>
- E 1354 Test Method for Heat and Visible Smoke Release Rates for Materials and Products Using an Oxygen Consumption Calorimeter<sup>5</sup>
- 2.2 *ASTM Proposal:*
- P147 Proposed Method for Room Fire Tests of Wall and Ceiling Materials and Assemblies<sup>7</sup>
- 2.3 *ISO Standards:*
- ISO 5657-1986(E) Fire Tests—Reaction to Fire—Ignitability of Building Materials<sup>8</sup>
- ISO 5660-1 Fire Tests—Reaction to Fire—Rate of Heat Release from Building Products<sup>8</sup>
- ISO 5725 Precision of Test Methods—Determination of Repeatability and Reproducibility for a Standard Test Method by Inter-Laboratory Tests<sup>8</sup>
- ISO 9705 Full Scale Room Test for Surface Products<sup>8</sup>

### 3. Terminology

#### 3.1 Definitions:

3.1.1 For definitions of terms used in this test method, refer to Terminology E 176.

#### 3.2 Definitions of Terms Specific to This Standard:

3.2.1 *effective heat of combustion*—the measured heat release divided by the mass loss for a specific time period.

3.2.2 *emissivity*—the ratio of the power per unit area radiated from a material's surface to that radiated from a black body at the same temperature.

3.2.3 *heat release rate*—the heat evolved from the specimen, per unit of time and area.

3.2.4 *heating flux*—the incident flux imposed externally from the heater on the specimen at the initiation of the test.

3.2.4.1 *Discussion*—the specimen, once ignited, is also heated by its own flame.

3.2.5 *ignitability*—the propensity to ignition, as measured by the time to sustained flaming, in seconds, at a specified heating flux.

3.2.6 *net heat of combustion*—the oxygen bomb (see Test Method D 3286) value for the heat of combustion, corrected for gaseous state of product water.

3.2.7 *orientation*—the plane in which the exposed face of the specimen is located during testing, either vertical or horizontal facing up.

3.2.8 *oxygen consumption principle*—the expression of the relationship between the mass of oxygen consumed during combustion and the heat released.

3.2.9 *smoke obscuration*—reduction of light transmission by smoke, as measured by light attenuation.

3.2.10 *sustained flaming*—existence of flame on or over most of the specimen surface for periods of at least 5 s.

3.2.10.1 *Discussion*—Flaming of less than 4 s duration is identified as flashing or transitory flaming.

### 4. Summary of Test Method

4.1 This is a test method designed to measure the rate of heat release from a specimen 1 m<sup>2</sup> in a vertical orientation. The specimen is exposed to a uniform heat flux from a gas fired radiant panel up to 50 kW/m<sup>2</sup> and ignited instantly. Heat release measured by this test method is based on the observation that, generally, the net heat of combustion is directly related to the amount of oxygen required for combustion (2, 3). The primary measurements of oxygen concentrations and exhaust flow are made as specified by Huggett (3). Burning may be either with or without a pilot ignition applied at the top and bottom of the specimen.

4.2 Additional measurements include the mass-loss rate of the specimen, surface temperature, the time to sustained flaming and the specimen's interior temperatures. The apparatus can be used to develop data relative to the other parameters discussed in 1.2 and 1.3.

### 5. Significance and Use

5.1 This test method is used primarily to determine the heat release rate of materials, products, and assemblies. Other parameters are the effective heat of combustion, mass loss rate, the time to ignition, smoke and gas production, emissivity, and surface temperature. Examples of test specimens are assemblies of materials or products that are tested in their end-use thickness. Therefore, the test method is suitable for assessing the heat release rate of a wall assembly.

5.2 Representative joints and other characteristics of an assembly shall be included in a specimen when these details are part of normal design.

5.3 This test method is applicable to end-use products not having an ideally planar external surface. The radiant flux field shall be adjusted to be that which is desired at the average distance of the surface from the radiant panel.

5.4 In this procedure, the specimens are subjected to one or more specific sets of laboratory test conditions. If different test conditions are substituted or the end-use conditions are changed, it is not always possible by or from this test to predict changes in the fire-test-response characteristics measured. Therefore, the results are valid only for the fire test exposure conditions described in this procedure.

#### 5.5 Test Limitations:

5.5.1 The test results have limited validity if: (a) the

<sup>4</sup> Discontinued; see 2000 Annual Book of ASTM Standards, Vol 05.06. Replaced by D5865.

<sup>5</sup> Annual Book of ASTM Standards, Vol 04.07.

<sup>6</sup> Annual Book of ASTM Standards, Vol 14.02.

<sup>7</sup> Discontinued; see 1983 Annual Book of ASTM Standards, Vol 04.07.

<sup>8</sup> Available from American National Standards Institute, 11 W. 42nd St., 13th Floor, New York, NY 10036.

specimen melts sufficiently to overflow the drip tray, or (b) explosive spalling occurs.

5.5.2 Exercise caution in interpreting results of specimens that sag, deform, or delaminate during a test. Report observations of such behavior.

## 6. Apparatus

### 6.1 General:

6.1.1 Where dimensions are stated in the following description, they shall be considered mandatory and shall be followed within nominal tolerance of  $\pm 5$  mm on the radiant panel and specimen holder assemblies. An exception to this tolerance is the placement of the screen in front of the ceramic burner that shall be  $\pm 0.5$  mm. The tolerances permitted in the exhaust system (see Proposal P147) for the proposed room fire test method or the ISO 9705 standard are permissible.

6.1.2 The apparatus shall consist of the following components: a radiant panel assembly (see Fig. 1) capable of vertical orientation only; a specimen holder (see Fig. 2), an infrared pyrometer (optional), an exhaust collection system, weighing platform, gas meter, and a data acquisition system. A general layout of the whole test assembly is shown in Fig. 3.

### 6.2 Radiant Panels:

6.2.1 The panel consists of a hollow 50 by 50 mm square steel tubing (see Fig. 1) that supports three rows of adjustable, ceramic-faced, natural gas burners<sup>9</sup> comprised of three burners per row. The tubing has typical residential water hose connections provided at the bottom of the tubing to facilitate water cooling.

6.2.2 The left and right burners in each row are made up of four modules each and the center burners are comprised of one module. A module consists of four vertically stacked ceramic

elements 12.7 mm deep by 95 mm high by 158 mm wide. The center burners consist of one module each. The modules are comprised of a plenum space in which the natural gas is injected at a controlled rate by the burner's control system. Combustion air is aspirated into the plenum space through the gas and air injection port.

6.2.3 The face of each burner is covered with stainless 330 floating screen for higher surface temperature and safety. The screens shall be carefully installed to allow for elongation of screens and supporting rods. This will allow the distance between the burners and screens to remain constant when heated. The optimum distance between the surface of the burners and the outer surface of the screen was found to be 20 mm. The rows of gas burners on the panel shall be separated by a distance of 112 mm from each other and shall be attached to the support tubing at the locations indicated in Fig. 1.

6.2.4 Natural gas of net heating value at least 790 kJ/mol shall be supplied to the unit through a control system provided with as safety interlock. All gas pipe connections to the burners must be sealed with a gas pipe compound resistant to liquified petroleum gases. A drip leg shall be installed in the gas supply line going to each heater to minimize the possibility of any loose scale or dirt within the gas supply line from entering the burner's control system.

6.2.5 Ignition of the burners shall be accomplished by individual, automatic spark igniters and pilot flames. The spark igniters are used to ignite the pilot flames which in turn are used to ignite the burners after pilot flame temperature sensors have reached a required value. The pilot remains on until the burners are extinguished.

6.2.6 An opening of at least 25 mm shall be provided at the vertical centerline between the rows of burners.

6.2.7 *Radiant Panel Constant Irradiance Controller*—The irradiance from the radiant panel assembly shall be capable of being held at a preset level by means of regulating the flow of natural gas to the burners (see X1.2 for more information). The flow of the gas is regulated using an automatic flow controller, motorized valve, and a thermocouple located on the surface of a ceramic burner. The irradiance is directly proportional to the temperature on the surface of the ceramic burners. Gas flow shall be continuously measured to calculate the heat released from the radiant panel assembly. This value is needed in computations of the heat release rate from the specimen.

### 6.3 Specimen Holder Assembly Components:

6.3.1 *Specimen Holder*—The specimen holder assembly is shown in Fig. 2 and is capable of holding a specimen up to 152 mm thick. (A thicker specimen holder is necessary to accommodate specimens thicker than 152 mm.) The top portion of the assembly is removable to facilitate specimen insertion. Prior to starting the test the specimen shall be protected from the radiant panel heat flux exposure by the water cooled shield (see 6.4.1). A drip tray, 300 mm wide by 50 mm deep by 914 mm long, shall be attached to the floor of the specimen holder directly below the specimen frame to contain limited amounts of materials that melt and drip. Two wire igniters described in 6.4.3 are attached to the specimen holder.

6.3.2 *Weighing Platform*—The general arrangement of the specimen holder and the weighing platform is indicated in Fig.

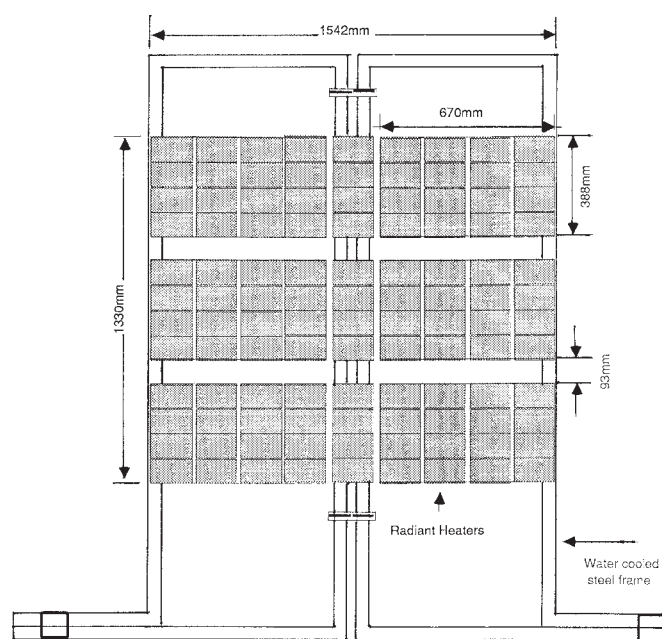

FIG. 1 Radiant Panel Assembly

<sup>9</sup> A modified RAY-TEC burner unit, RT132, from Sun Technology Corp., 14329 23 Mile Road, Shelby TWP., MI 48315 has been found suitable for this application.

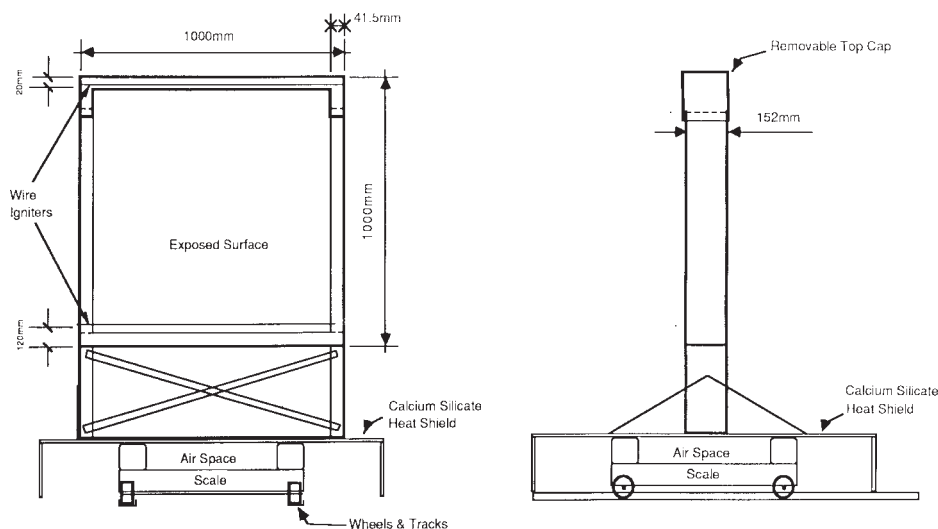

FIG. 2 Sample Holder

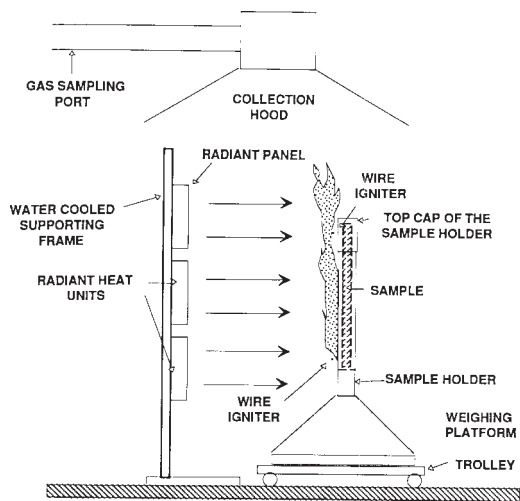

FIG. 3 Intermediate Scale Calorimeter

2. The weighing platform<sup>10</sup> shall be capable of weighing the specimen to an accuracy of one gram. The platform shall be protected from the radiant panel assembly by an insulation board cover as shown in Fig. 2.

6.3.3 *Specimen Holder Trolley*—A trolley, as shown in Fig. 3, shall be provided to hold the specimen holder and weighing platform to permit movement of the specimen to a predetermined location in front of the radiant panel at the beginning of a test. The trolley shall be placed on rails or guides to facilitate exact specimen placement with respect to the radiant panel. The trolley tracks shall be located perpendicular to the plane of the radiant panel so that the specimen is moved directly toward the radiant panel. The trolley tracks shall be long enough to move the specimen holder to a distance of 6 m from the radiant panel. This distance makes mounting the specimen easier and allows testing of parameters other than heat release at very low

heat fluxes. Heat flux values of 25 and 50 kW/m<sup>2</sup> are achieved at distances less than 1 m.

6.4 *Other Major Components:*

6.4.1 *Specimen Shield*—A water cooled shield (see Fig. 4) shall be provided to absorb the thermal energy from the radiant panels prior to testing. The shield is constructed so that a preset water flow will maintain a shield temperature on the unexposed face below 100°C. The shield shall be positioned directly in front of the radiant panel assembly at a distance of 150 mm. The mounting method used shall accommodate removing the

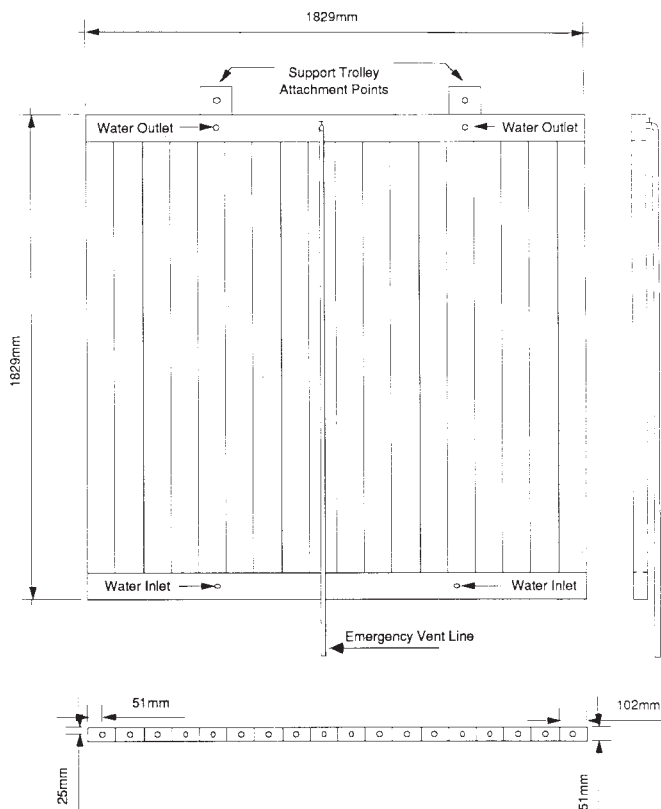

FIG. 4 Radiation Shield

<sup>10</sup> A Sartorius Model F150S Electromagnetic Scale, has been found suitable for this application.

shield in less than 2 s.

6.4.2 *Infrared Pyrometer*—A pyrometer<sup>11</sup> is used to view the specimen surface through the 25 mm gap between the radiant panels. The pyrometer is positioned 0.3 m to 0.5 m behind the radiant panel assembly at a height equal to the geometrical center of the specimen. The measurement technique including specimen emissivity adjustments is detailed in (4).

6.4.3 *Wire Igniters*—Two 0.81 mm Chromel wires (from Type K thermocouple wires) are used as igniters. One wire is positioned horizontally, spanning the full width of the specimen, 80 mm above the bottom exposed edge of the specimen and 15 mm from the specimen surface. The other wire is positioned horizontally, spanning the full width of the specimen, 20 mm above the top exposed edge of the specimen and 15 mm from the specimen's vertical plane. A spring, protected from the radiant heat, shall be attached to one end of the wires to compensate for the wire expansion during the test. It shall remain under tension throughout the test so that the igniter wire remains in position. When used, sufficient power shall be applied to the wire that will produce an orange glow. Low voltages, up to 30 V, shall be used for safety reasons. More information about the choice of the wire igniters is given in X1.3.

6.4.4 *Heat Flux Meter*—The total heat flux meter shall be of the Gardon<sup>12</sup> (foil) or Schmidt-Boelter (thermopile) type, with a design range of about 50 kW/m<sup>2</sup>. The target receiving radiation, and possibly to a small extent convection, shall be flat, circular, approximately 12.5 mm in diameter, and coated with a durable matt-black finish. The target shall be water cooled. Radiation shall not pass through any window before reaching the target. The instrument shall be robust, simple to set up and use, and stable in calibration. The instrument shall have an accuracy of within ±3 % and a repeatability of within 0.5 %.

6.4.5 *Heat Flux Calibration Panel*—A panel to establish the heat flux/distance relationship shall be constructed from nomi-

nal 12.7 mm thick calcium silicate board of nominal density 740 kg/m<sup>3</sup>. The panel shall be the same size as a specimen (1000 by 1000 mm) and shall have holes with diameters to accommodate the heat flux meter from 6.4.4. Five rows and columns of holes shall be drilled 224 mm apart and 51 mm from the edges on all sides of the panel.

6.4.6 *Digital Data Collection*—The data collection system shall be equal to or better than that required in Proposal P147. Readings shall be made at intervals not exceeding 2 s.

6.4.7 *Exhaust Collection System*:

6.4.7.1 Construct the exhaust collection system with the following minimal requirements: a blower, steel hood, duct, bidirectional probe, thermocouple(s), oxygen measurement system, smoke obscuration measurement system (white light photocell lamp/detector or laser) and combustion gas sampling and analysis system. Construct the exhaust collection system as shown in Fig. 5 and as explained in Annex A1.

6.4.7.2 Ensure that the system for collecting the smoke (which includes gaseous combustion products) has sufficient exhaust capacity and is designed in such a way that all of the combustion products leaving the burning specimen are collected. Design the capacity of the evacuation system such that it will exhaust minimally all combustion gases leaving the specimen (see A1.1.4).

6.4.7.3 Place probes for sampling of combustion gas and for measurement of flow in accordance with 6.4.8.

6.4.7.4 Make all measurements of smoke obscuration, gas concentrations or flows at a position in the exhaust duct where the exhaust is uniformly mixed so that there is a nearly uniform velocity across the duct section.

6.4.7.5 If the straight section before the measuring system is at least eight times the inside diameter of the duct the exhaust is likely to be uniformly mixed. If a measuring system is positioned at a distance of less than eight diameters, demonstrate the achievement of equivalent results.

6.4.8 *Instrumentation in Exhaust Duct*—The following specifications are minimum requirements for exhaust duct instrumentation. Additional information is found in Annex A2.

6.4.8.1 *Flow*—Measure the flow in the exhaust duct by means of a bidirectional probe, or an equivalent measuring system, with an accuracy of at least ±6 % (see Annex A2 for further details). The response time to a stepwise change of the duct flow shall not exceed 5 s, to reach 90 % of the final value.

<sup>11</sup> A Maxline Infrared Pyrometer with M402 Sensor, made by Iacon, Inc. in Illinois has been found suitable for this use. The band of wavelength in which the sensor responds to the infrared radiation is 8 to 12 μm to avoid the water and carbon monoxide bands.

<sup>12</sup> A Medtherm Model R-8015-C-15-072, from Medtherm Corp., Huntsville, AL, has been found suitable for this purpose.

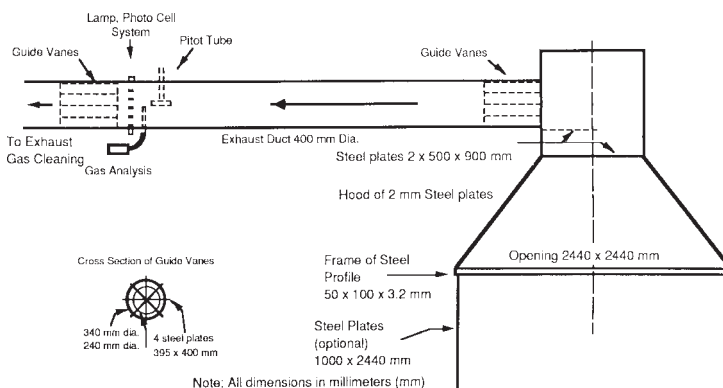

**FIG. 5 Collection Hood and Exhaust System**

6.4.9 Combustion Gas Analysis:

6.4.9.1 *Sampling Line*—Construct the sampling line tubes of a material not influencing the concentration of the combustion gas species to be analyzed. The following sequence of the gas train has been shown to be acceptable: sampling probe, soot filter, cold trap, gas path pump, vent valve, plastic drying column and carbon dioxide removal columns (if used), flow controller and oxygen analyzer (see Fig. 6 and Annex A2 for further details). Alternative designs of the sampling line must give equivalent results. The gas train shall also include appropriate spanning and zeroing facilities.

6.4.9.2 *Oxygen Measurement*—Measure the oxygen concentration with an accuracy of at least  $\pm 0.04\%$  of full scale in the output range of 0 to 25 vol % oxygen, or  $\pm 0.01\%$  vol % oxygen, in order to have adequate measurements of rate of heat release. Take the combustion gas sample from the end of the sampling line. Calculate the time delay, including the time constant of the instrument; it is a function of the exhaust duct flow. This time delay shall not exceed 60 s. (See Annex A6 for further details.)

6.4.9.3 *Carbon Monoxide and Carbon Dioxide Measurement*—Measure the combustion gas species with an instrument having an accuracy of at least  $\pm 0.1\%$  for the carbon dioxide and  $\pm 0.02\%$  for carbon monoxide. A suitable output range is 0 to 1 vol % for carbon monoxide and 0 to 6 vol % for carbon dioxide. Take the combustion gas sample from the end of the sampling line. Calculate the time delay, including the time constant of the instrument; it is a function of the exhaust duct flow. It shall be a maximum of 60 s. (See Annex A6 for further details.)

6.4.10 *Smoke Obscuration Measurement:*

6.4.10.1 Install an optical system for measurement of light obscuration across the centerline of the exhaust duct. Determine the optical density of the smoke by measuring the light transmitted with a photometer system consisting of a white light source and a photocell/detector or a laser system for measurement of light obscuration across the centerline of the exhaust duct.

6.4.10.2 One photometer system found suitable consists of a lamp, lenses, an aperture, and a photocell. See Fig. 7 and

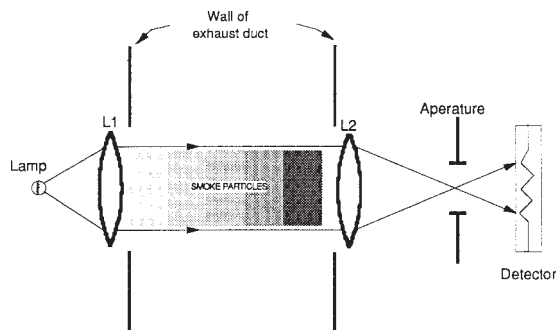

FIG. 7 White Light Optical System

Annex A2 for further details. Construct the system so that soot deposits on the optics during a test do not reduce the light transmission by more than 5 %.

6.4.10.3 Alternatively, instrumentation constructed using a 0.5 to 2.0 mW helium-neon laser, instead of a white light system is also acceptable. See Fig. 8 and A2.4 for further details. It has been shown that white light and laser systems will give similar results (5, 6).

6.4.11 *Thermocouples:*

6.4.11.1 All thermocouples shall be 0.127 mm (0.005 in. or 5 mils) Type K, Chromel-Alumel.

6.4.11.2 The location of the minimum number of thermocouples for measurement of homogeneous sample temperature shall be at the geometric center of the sample and on the centerline through the sample as follows: Surface, 1/4 depth, 1/2 depth, 3/4 depth and unexposed surface. Other temperatures may be taken as needed to gain specific information such as interface temperatures between assemblies of materials.

6.4.11.3 The interior thermocouples shall be inserted in holes that have been predrilled from the unexposed face of the sample toward the face to the desired depth. These thermocouples shall be sheathed with ceramic insulation.<sup>13</sup> The two wires leading up to the junctions of surface thermocouples

<sup>13</sup> 0.4 mm (1/64 in.) bore diameter insulators from Omega Engineering, One Omega Drive, Stamford, CT has been found suitable for this.

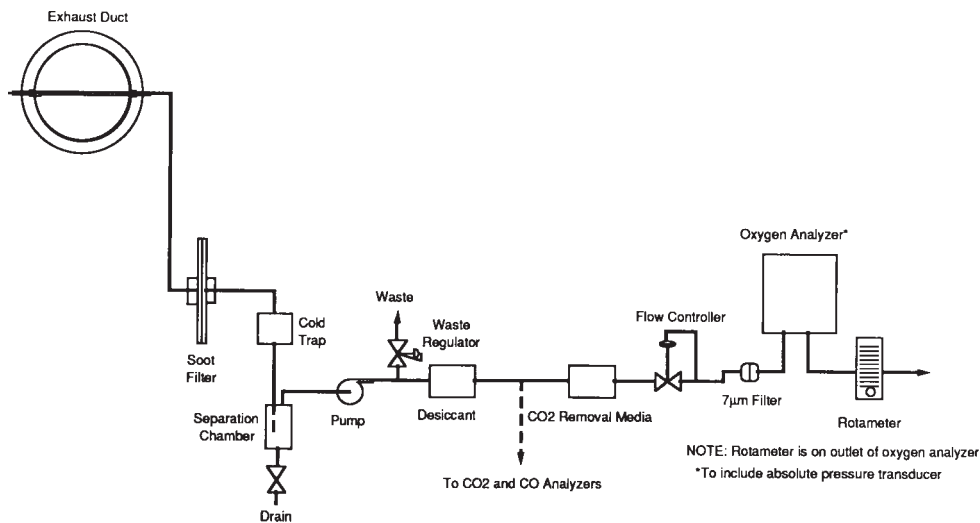
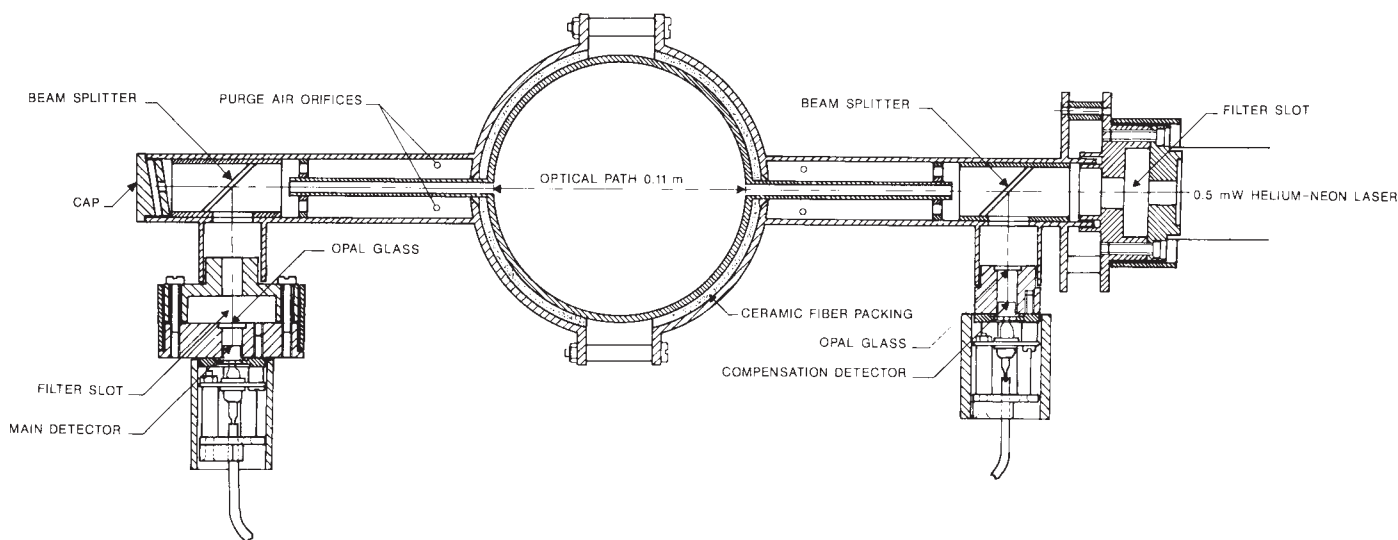

FIG. 6 Schematic of Gas Sampling Train



**FIG. 8 Smoke Obscuration Measuring System**

shall be bared for a distance of at least 50 mm on both sides of the junction. Each lead shall be pulled tight so that the bead is contacting the surface and stapled at a point on each wire 25 mm away from the junction. The bead shall be pushed by thumb with moderate force into the surface if it will penetrate.

## 7. Hazards

7.1 The test procedures involve high temperatures and combustion processes. Therefore the potential exists for burns, ignition of extraneous objects or clothing, and for inhalation of combustion products. The operator shall use protective gloves and clothes while removing the specimen shield and while moving the specimen trolley toward or away from the radiant panels. The construction of a viewing wall with windows is recommended for laboratories with small spaces where the operator and viewers cannot move far enough away from the area of the radiant panel.

7.2 The water cooled shield placed in front of the radiant panel assembly dramatically lowers the heating of the laboratory space. Additionally, it lowers the potential for harm to operators working in the area.

## 8. Test Specimens

### 8.1 Size and Preparation:

8.1.1 Test specimen's dimensions shall be 1000 by 1000 mm and up to 152 mm in thickness<sup>14</sup>. They shall be representative of the construction of the end-use product. Test materials and assemblies of normal thickness, 152 mm or less, using their full thickness.

8.1.2 If a product is designed to normally have joints in a field application, then that specimen shall incorporate the joint detail. Center the joint in the specimen's vertical or horizontal centerline as appropriate. Also test the specimen without a joint detail if the design does not include a joint.

8.1.3 Cover the edges of the specimen with 12 mm ceramic wool blanket to eliminate the gap between the holder and the specimen.

8.2 *Conditioning*—Condition specimens to moisture equilibrium (constant weight) at an ambient temperature of  $23 \pm 3^\circ\text{C}$  and a relative humidity of  $50 \pm 5\%$ . Constant weight is achieved when two weighings differ by no more than 0.2 % in 24 h.

## 9. Calibration

9.1 Calibrate all instruments carefully with standard sources after initial installation. Among the instruments to be calibrated are load cells or weighing platforms, smoke meters, flow or velocity transducers, infrared pyrometer and gas analyzers.

### 9.2 Heat Flux/Distance Relationship:

9.2.1 Ignite the radiant panel and allow it to come to equilibrium as indicated by its constant heat release rate.

9.2.2 Generate a curve of average flux measurements over the specimen surface versus specimen distance from the radiant panels. Place the calibration panel in the same position as a specimen and insert the flux meter from the unexposed face through the holes. The target face of the flux meter shall extend 15 mm toward the radiant panel from the exposed surface of the calibration panel to minimize the convective heat transfer contribution. After the calibration panel has come to equilibrium, make the flux measurements with the target face of the flux meter at the following distance away from the radiant panel: 200, 400, 600, 800, 1000, 2000, 3000, 4000, 5000, and 6000 mm.

9.2.3 No individual flux measurement shall deviate from the average at each of the distances by more than  $\pm 5\%$ .

9.2.4 Use the curve generated in 9.2.2 to determine the distance from the radiant panel for a desired radiant heat flux exposure.

9.2.5 Perform calibration every three months or more frequently if any significant changes to equipment are made or if calibration is suspect.

### 9.3 Heat Release:

9.3.1 Perform the calibration of the heat release instrumentation in the exhaust duct by burning propane or methane gas and comparing the heat release rates calculated from the metered gas input, and those calculated from the measured

<sup>14</sup> If specimens of thickness greater than 152 mm are to be tested, a specimen holder shall be constructed to accommodate the desired specimen thickness.

oxygen consumption. The value of net heat of combustion for methane is 50.0 MJ/kg and that for propane is 46.5 MJ/kg. Position the calibration burner in the same location where the specimen is to be placed during a 35 kW/m<sup>2</sup> exposure test. Measure the gas flow at a pressure of 101 ± 5 kPa (standard atmospheric pressure, measured at the flow gage) and a temperature of 20 ± 5°C.

9.3.2 A suitable calibration burner is a sand diffusion burner with a 0.3 by 0.3 m top surface and a 0.15 m depth. Construct such a gas burner with a 25 mm thick plenum. Alternatively, use a minimum 100 mm layer of Ottawa sand to provide the horizontal surface through which the gas is supplied. This type of burner is shown in Fig. 9. The gas supply to the burner shall be technical grade propane or methane. Do not premix the gas for the burner flame with air. Meter the flow of gas and keep it constant throughout the calibration test.

9.3.3 Another suitable calibration burner is a pipe, with an inner diameter of 100 ± 1.5 mm, supplied with gas from beneath (see ISO 9705). Do not premix the gas for the burner flame with air.

9.3.4 Obtain a minimum of two calibration points. Obtain a lower heat release rate value of 40 kW and then a higher heat release rate value of 160 kW. Approximate propane flows for any required heat release rate value are estimated using the following constant: 1.485 kW min/L, determined at a pressure of 101 ± 5 kPa (standard atmospheric pressure; measured at the flow gage) and a temperature of 20 ± 5°C.

9.3.5 Take measurements at least once every 6 s and start 1 min prior to ignition of the burner. Determine the average rate of heat release over a period of at least 1 min by the oxygen consumption method and calculating the heat release rate from

the gas mass flow and the net heat of combustion. The difference between the two values shall not exceed 5 %. Make this comparison only after steady state conditions have been reached.

9.3.6 Perform calibration every three months or more frequently if any significant changes to equipment are made or if calibration is suspect.

9.3.7 When calibrating a new system, or when modifications are introduced, check the response time of the measuring system by the following test sequence:

Time, min	Burner Output, kW
0 to 5	0
5 to 10	40
10 to 15	160
15 to 20	0

The response of the system to a stepwise change of the heat output from the burner shall be a maximum of 12 s to 90 % of final value.

9.3.8 Perform the calibration in 9.3.7 at a duct air flow of 2 m<sup>3</sup>/s.

9.3.9 The change in measured rate of heat release, comparing time average values over 1 min, shall not be more than 10 % of the actual heat output from the burner.

9.4 *Mass Loss*—If required by the type of scale used, perform the calibration by loading the weighing platform with known masses corresponding to the measuring range of interest, to ensure that the requirements of accuracy in 6.3.2 are fulfilled. Carry out this calibration daily, prior to testing.

9.5 *Smoke Obscuration*—Calibrate the smoke meter initially to read correctly for two neutral density filters of significantly different values, and also at 100 % transmission. The use of neutral density filters at 0.5 and 1.0 values of optical density has been shown to be satisfactory for this calibration. Once this calibration is set, only the zero value of extinction coefficient (100 % transmission) needs to be verified each day, prior to testing. Investigate any excessive departure from the zero line at the end of a test, and correct it.

9.6 *Gas Analysis*—Calibrate gas analyzers daily, prior to testing (see Guide E 800 for further guidance).

9.7 *Heat Flux Meter*—Check the calibration of the heat flux meter whenever a recalibration of the apparatus is carried out by comparison with an instrument (of the same type as the working heat flux meter and of similar range) held as a reference standard and not used for any other purpose. Fully calibrate the reference standard at a standardizing laboratory at yearly intervals.

## 10. Procedure

### 10.1 Preparation:

10.1.1 Open the water valve to the steel tubing that support the radiant panel and adjust the water flow sufficiently high that water exiting the frame will not exceed 50°C in temperature.

10.1.2 Position the specimen holder assembly remote to the desired test location.

10.1.3 Place the water cooled shield in front of the radiant panel assembly and adjust the water flow sufficiently high that water exiting the shield will not exceed 50°C in temperature.

10.1.4 Insert the specimen into the specimen holder. Place the specimen in the specimen holder by removing the top

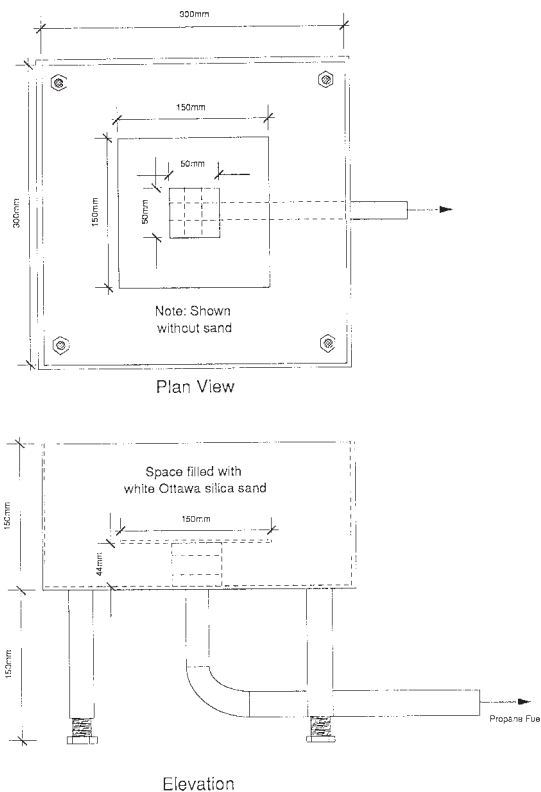

**FIG. 9 Sand Burner**



specimen holder cap section, inserting the specimen, and replacing the top cap.

10.1.5 Establish a duct flow of 1.6 m<sup>3</sup>/s.

10.1.6 Turn on the flow of gas to each of the radiant panels and ignite them.

10.1.7 Allow the burners to operate for 30 min prior to testing.

10.1.8 Turn on all sampling and recording devices and calibrate the analyzers.

10.1.9 For a standard test where gas phase ignition is desired, switch on the wire igniters.

10.1.10 Set predetermined material emissivity on the infrared pyrometer if used (4).

10.1.11 If heat flow through the specimen is to be monitored, attach the thermocouples as described in 6.4.2 and 6.4.3.

#### 10.2 Procedure:

10.2.1 Move the specimen trolley to the location necessary for the desired flux exposure.

10.2.2 Collect baseline data for 2 min after the signal from the weighing platform settles down to equilibrium.

10.2.3 Remove the water cooled specimen shield in not more than 2 s and start the timer marking the beginning of the test.

10.2.4 Record the time when flashing or transitory flaming occur; when sustained flaming occurs, record the time and turn off the igniters. If the flame extinguishes in less than 60 s after turning off the igniters, turn on the igniters again. If flaming reoccurs, stop the test, discard the test data and repeat the test without turning the igniters off until the entire test is completed. Report these events in the test report.

10.2.5 If the duct flow is not sufficient to collect all the fire gases, then increase the duct flow.

10.2.6 Record all important events during the test like cracking, melting, collapse of all or part of the specimen, deformations, and intumescing.

10.2.7 Collect data until 2 min after sustained flaming occurs on the unexposed side of the specimen or a predetermined time period.

10.2.8 Unless otherwise specified in the material or performance standard, make three determinations and report as specified in Section 12.

### 11. Calculation

11.1 Calculate the specimen heat release rate by subtracting the radiant panel assembly heat release rate (baseline) from the total heat release rate. Considerations for heat release measurements are presented in Annex A3. Calculate heat release data, using the equations presented in A4.1 and A4.2. The testing laboratory shall choose one of the equations in A4.1 to calculate heat release, based on the gas analyzers installed.

11.2 Calculate mass loss rate and effective heat of combustion using the procedures in Annex A5.

11.3 Calculate smoke release data using the equations in A4.3.

11.4 Calculate gas yield data using the equations in A4.4.

11.5 Calculate the specimen carbon monoxide and carbon dioxide concentrations by subtracting the radiant panel contributions (baseline data) from the total values.

11.6 The exposed surface area of the specimen is 0.84 m<sup>2</sup>.

Use 0.84 m<sup>2</sup> to calculate parameters per unit surface area.

### 12. Report

12.1 Report the following information:

12.2 *Descriptive Information:*

12.2.1 Name and address of the testing laboratory,

12.2.2 Specimen identification code or number,

12.2.3 Date and identification number of the report,

12.2.4 Name and address of the test sponsor,

12.2.5 Name of product manufacturer or supplier, if known,

12.2.6 Composition or generic identification,

12.2.7 Density, or mass per unit surface area, total mass, thickness of the main components in the specimen, thickness of the specimen, moisture content of hygroscopic materials and mass of combustible portion of specimen, if known,

12.2.8 Description of the specimen, if different from the product,

12.2.9 Details of specimen preparation by the testing laboratory,

12.2.10 Details of special mounting methods used,

12.2.11 Heating flux and exhaust system flow,

12.2.12 Number of replicates tested under the same conditions. (This shall be a minimum of three except for exploratory testing),

12.2.13 Conditioning of the specimens,

12.2.14 Date of test, and

12.2.15 Test number and any special remarks.

12.3 *Test Results: (See Also Appendix):*

12.3.1 Table of numerical results containing:

12.3.1.1 Time to sustained flaming(s),

12.3.1.2 Peak rate of heat release (kW), and the time at which it occurred(s),

12.3.1.3 Average rate of heat release values for the first 60, 180, 300 s after ignition, or for other appropriate periods (kW),

12.3.1.4 Total heat released (MJ),

12.3.1.5 Peak rate of smoke release (m<sup>2</sup>/s), and the time at which it occurred,

12.3.1.6 Average rate of smoke release values for the first 60, 180, 300 s after ignition, or for other appropriate periods (m<sup>2</sup>/s),

12.3.1.7 Total smoke released (m<sup>2</sup>),

12.3.1.8 Total mass loss (kg),

12.3.1.9 Total percentage of mass loss (%),

12.3.1.10 Average effective heat of combustion for the entire test (MJ/kg),

12.3.1.11 Peak yield of carbon monoxide (kg of CO/kg of fuel),

12.3.1.12 Equation used to calculate rate of heat release,

12.3.1.13 Peak optical density of smoke (optional),

12.3.1.14 Total percentage of combustible mass loss (%) (optional),

12.3.1.15 Average yield of carbon monoxide (kg CO/kg fuel) (optional),

12.3.1.16 Average yield of carbon dioxide (kg CO<sub>2</sub>/kg fuel) (optional),

12.3.1.17 Carbon monoxide/carbon dioxide yield ratio (kg of CO/kg of CO<sub>2</sub>) (optional),

12.3.1.18 Average yield of any other measured combustion gas (kg combustion gas/kg fuel) (optional), and

12.3.1.19 Material emissivity.

12.3.2 *Graphical Results:*

12.3.2.1 Plot of rate of heat release versus time,

12.3.2.2 Plot of rate of smoke release versus time,

12.3.2.3 Plot of optical density versus time,

12.3.2.4 Plot of mass loss versus time,

12.3.2.5 Plot of mass loss rate versus time,

12.3.2.6 Plot of effective heat of combustion versus time,

12.3.2.7 Plots of all temperatures (including duct) versus time,

12.3.2.8 Plot of concentration of carbon monoxide versus time,

12.3.2.9 Plot of concentration of carbon dioxide versus time,

12.3.2.10 Plots of concentration of any other measured combustion gas versus time,

12.3.2.11 Plot of mass flow in the exhaust duct versus time,

12.3.2.12 Plot the rate of heat release versus time from the radiant panel, and

12.3.2.13 Report of smoke obscuration, carbon monoxide, and temperature measurements in the room in the same fashion, if they have been made.

12.3.3 *Descriptive Results:*

12.3.3.1 Photographs or videotape of the fire development, and

12.3.3.2 All available information requested in 12.2, including information on physical changes to the specimen during the test (see 5.5).

### 13. Precision and Bias

13.1 Information on reproducibility is presented in 13.2-13.4. Information on repeatability obtained from an early study in a single laboratory (9) also is available.

13.2 An interlaboratory study was performed, using the three laboratories available in the United States, in which test materials were chosen intended to challenge the capabilities of the instrument. The test materials provided a broad range of fire-test-response characteristics and offered the expected testing difficulties. Details of the experimental work and of the results can be found in Ref (10). The three laboratories tested six samples in triplicate, and one laboratory each tested the seventh and eighth sample in triplicate. The materials selected are described in 13.2.1-13.2.8

13.2.1 *Oriented Strand Board*, 11 mm thick, tested at a heat flux of 25 kW/m<sup>2</sup>(OSB 25).

13.2.2 *Oriented Strand Board*, 11 mm thick, tested at a heat flux of 50 kW/m<sup>2</sup>(OSB 50).

13.2.3 *Composite Building Panel (Structural Grid Composite)*, 70 mm thick, tested at a heat flux of 25 kW/m<sup>2</sup>(CBP 25).

13.2.4 *Poly(Methyl Methacrylate) Sheet*, 25 mm thick, tested at a heat flux of 25 kW/m<sup>2</sup>(PMMA 25).

13.2.5 *Wall Covering System (Vinyl Film on Thick Fiberglass Panel)*, 25 mm thick, tested at a heat flux of 25 kW/m<sup>2</sup>(WALL 25).

13.2.6 *Fire Retardant Treated Plywood*, 13 mm thick, tested at a heat flux of 50 kW/m<sup>2</sup>(FRT 50).

13.2.7 *Hardboard (Wood-Fibre) Siding (With Imitation Stucco Surface)*, 9 mm thick, tested by one laboratory at a heat flux of 25 kW/m<sup>2</sup>(STC 25).

13.2.8 *Hardboard (Wood-Fibre) Siding (With Imitation Stucco Surface)*, 9 mm thick, tested by one laboratory at a heat flux of 50 kW/m<sup>2</sup>(STC 50).

13.2.9 Examples of testing difficulties inherent in the materials chosen include the following: the wall covering system consisted of a very thin combustible material mounted on a noncombustible backing, so that the period between ignition and extinction was short; the poly(methyl methacrylate) sheet was capable of sagging and eventually melting and dripping; and, the composite building panel was very thick and inhomogeneous.

13.3 Experimental uncertainty can be evaluated by a standard statistical method for treating data or based on scientific judgement using all the relevant information available. For this analysis, the statistical method used was Practice E 691, but scientific judgement was used to eliminate outliers, particularly in terms of smoke obscuration, where some of the results obtained clearly could be seen to be out of line.

13.4 The results of the statistical analysis of this round robin evaluation are found in Tables 1 and 2. The relative standard deviations for repeatability are < 30 % for seven out of nine properties and those for reproducibility are < 30 % for four out of nine properties. The relative standard deviations for repeatability and reproducibility show similar patterns, but the former is significantly better, as expected. The difficulties encountered in testing some of the materials are illustrated by their statistical data, as shown in Table 2. Considering the difficulties inherent in testing such materials, the precision of the test results from the nonwood materials was comparable to that of the wood materials.



**E 1623 – 02**

**TABLE 1 Overall Statistical Data, by Property from Three Laboratories<sup>A</sup>**

	Avg	RSD Rept	RSD Repro	STD Rept	STD Repro
Pk RHR, kW/m <sup>2</sup>	299	22	28	60	74
Time Ign, s	93	19	20	24	27
THR, MJ/m <sup>2</sup>	69	22	36	18	29
Ht Comb, MJ/kg	11	26	39	3	4
Mass Loss, %	42	21	26	6	7
Pk RSR, m <sup>2</sup> /s	12	36	43	4	6
TSR, m <sup>2</sup>	746	35	36	269	339
Pk RHR, kW	255	22	28	51	58
THR, MJ	59	21	35	15	25

<sup>A</sup>Abbreviations of statistical terms used: Avg: average; STD Repeat: Standard deviation for repeatability (that is within laboratories); STD Repro: standard deviation for reproducibility (that is between laboratories); *r*: repeatability; *R*: reproducibility, RSD repeat: relative standard deviation for repeatability (that is 100 times ratio of STD repeat and Avg); RSD Repro: relative standard deviation for reproducibility (that is 100 times ratio of STD Repro and Avg).

**TABLE 2 Summary Table of Precision Data from Three Laboratories**

Material/Flux	Property	Avg	STD Repeat	STD Repro	<i>r</i>	<i>R</i>	RSD Repeat	RSD Repro
OSB-25	Pk RHR, kW/m <sup>2</sup>	168	41	54	115	151	25	32
OSB-50	Pk RHR, kW/m <sup>2</sup>	287	51	51	143	143	18	18
CBP-25	Pk RHR, kW/m <sup>2</sup>	403	226	226	632	632	56	56
PMMA-25	Pk RHR, kW/m <sup>2</sup>	793	63	63	178	178	8	8
WALL-25	Pk RHR, kW/m <sup>2</sup>	70	24	24	68	68	35	35
FRT-50	Pk RHR, kW/m <sup>2</sup>	110	22	24	61	66	20	21
STC-25	Pk RHR, kW/m <sup>2</sup>	245	16		44		7	
STC-50	Pk RHR, kW/m <sup>2</sup>	320	37		105		12	
Overall	Pk RHR, kW/m <sup>2</sup>	299	60	74	168	206	22	28
OSB-25	Time Ign, s	106	16	16	45	45	15	15
OSB-50	Time Ign, s	19	6	6	18	18	34	34
CBP-25	Time Ign, s	109	45	45	125	125	41	41
PMMA-25	Time Ign, s	156	84	84	236	236	54	54
WALL-25	Time Ign, s	17	8	8	22	22	45	45
FRT-50	Time Ign, s	17	3	3	9	9	19	20
STC-25	Time Ign, s	255	25		70		10	
STC-50	Time Ign, s	69	7		20		10	
Overall	Time Ign, s	93	24	27	68	76	29	35
OSB-25	THR, MJ/m <sup>3</sup>	30	4	13	12	35	15	42
OSB-50	THR, MJ/m <sup>2</sup>	49	17	17	47	47	34	34
CBP-25	THR, MJ/m <sup>2</sup>	21	5	7	15	20	25	34
PMMA-25	THR, MJ/m <sup>2</sup>	299	97	131	272	368	33	44
WALL-25	THR, MJ/m <sup>2</sup>	1.9	0.5	0.7	1.4	2.0	26	37
FRT-50	THR, MJ/m <sup>2</sup>	25	6	6	17	18	24	26
STC-25	THR, MJ/m <sup>2</sup>	51	2.1		6		4	
STC-50	THR, MJ/ms <sup>2</sup>	78	10		28		13	
Overall	THR, MJ/m <sup>2</sup>	69	18	29	50	82	22	36
OSB-25	Ht Comb, MJ/kg	6	1.8	3	5	8	29	45
OSB-50	Ht Comb, MJ/kg	10	2.1	2.1	6	6	21	21
CBP-25	Ht Comb, MJ/kg	16	7	8	19	22	41	49
PMMA-25	Ht Comb, MJ/kg	22	6	6	17	17	26	28
WALL-25	Ht Comb, MJ/kg	3	1.1	1.4	3	4	39	48
FRT-50	Ht Comb, MJ/kg	6	3	3	8	8	45	45
STC-25	HT Comb, MJ/kg	11	0.4		1.1		3	
STC-50	HT Comb, MJ/kg	14	0.3		0.8		2.1	
Overall	Ht Comb, MJ/kg	11	3	4	7	11	26	39
OSB-25	Mass Loss, %	55	10	10	27	27	18	18
OSB-50	Mass Loss, %	58	7	7	19	19	12	12
CBP-25	Mass Loss, %	18	6	6	16	16	31	31
PMMA-25	Mass Loss, %	43	12	12	34	34	29	29
WALL-25	Mass Loss, %	7	4	4	11	11	54	56
FRT-50	Mass Loss, %	48	4	4	11	11	8	8
STC-25	Mass Loss, %	48	3		7		6	
STC-50	Mass Loss, %	56	6		17		11	
Overall	Mass Loss, %	42	6	7	18	20	21	26
OSB-25	Pk RSR, m <sup>2</sup> /s	2.0	0.6	0.6	1.7	1.7	32	32
OSB-50	Pk RSR, m <sup>2</sup> /s	2.4	0.4	0.4	1.1	1.1	18	18
CBP-25	Pk RSR, m <sup>2</sup> /s	44	6	15	16	41	13	33
PMMA-25	Pk RSR, m <sup>2</sup> /s	4	2.2	2.2	6	6	53	53
WALL-25	Pk RSR, m <sup>2</sup> /s	34	17	17	48	48	50	50
FRT-50	Pk RSR, m <sup>2</sup> /s	1.6	1.2	1.2	3	3	73	73
STC-25	Pk RSR, m <sup>2</sup> /s	2.1	0.1		0.3		6	

**TABLE 2** *Continued*

Material/Flux	Property	Avg	STD Repeat	STD Repro	<i>r</i>	<i>R</i>	RSD Repeat	RSD Repro
STC-50	Pk RSR, m <sup>2</sup> /s	4	1.8		5		44	
Overall	Pk RSR, m <sup>2</sup> /s	12	4		10		36	43
OSB-25	TSR, m <sup>2</sup>	467	302	302	844	844	65	65
OSB-50	TSR, m <sup>2</sup>	300	113	113	318	318	38	38
CBP-25	TSR, m <sup>2</sup>	1857	115	270	322	755	6	15
PMMA-25	TSR, m <sup>2</sup>	2001	1238	1238	3467	3467	62	62
WALL-25	TSR, m <sup>2</sup>	534	100	100	280	280	19	19
FRT-50	TSR, m <sup>2</sup>	45	9	9	25	25	20	20
STC-25	TSR, m <sup>2</sup>	282	65		182		23	
STC-50	TSR, m <sup>2</sup>	481	208		581		43	
Overall	TSR, m <sup>2</sup>	746	269	339	753	948	35	36
OSB-25	Pk RHR, kW	142	35	46	98	129	25	32
OSB-50	Pk RHR, kW	250	43	43	120	120	18	18
CBP-25	Pk RHR, kW	341	190	173	532	486	56	56
PMMA-25	Pk RHR, kW	671	54	48	150	135	8	8
WALL-25	Pk RHR, kW	59	20	19	57	54	34	34
FRT-50	Pk RHR, kW	93	19	21	52	57	20	22
STC-25	Pk RHR, kW	211	14		39		7	
STC-50	Pk RHR, kW	269	31		88		12	
Overall	Pk RHR, kW	255	51	58	142	163	22	28
OSB-25	THR, MJ	25	4	11	11	30	16	42
OSB-50	THR, MJ	42	14	14	40	40	34	34
CBP-25	THR, MJ	18	5	7	13	20	26	35
PMMA-25	THR, MJ	254	82	112	229	312	32	44
WALL-25	THR, MJ	1.8	0.3	0.5	0.8	1.4	17	27
FRT-50	THR, MJ	21	5	6	15	16	25	27
STC-25	THR, MJ	44	2.1		6		5	
STC-50	THR, MJ	66	9		24		13	
Overall	THR, ML	59	15	25	42	70	21	35

### 13.5 Bias:

13.5.1 For solid test specimens of unknown chemical composition, as used in building materials, furnishings, and common occupant fuel load, documentation exists [1, 18] stating that the use of the relationship that approximately 13.1 MJ of heat are released per 1 kg of oxygen consumed results in an expected error band of  $\pm 5\%$  compared to true value. For homogeneous materials with only a single pyrolysis mechanism, this uncertainty is reduced by determining the net heat of combustion from oxygen bomb measurements and the oxygen-fuel stoichiometric mass ratio from ultimate elemental analysis. For most testing, this is not practical, since test specimens are composites, and usually nonhomogeneous; therefore, they often exhibit several degradation reactions. For unknown samples, therefore, a  $\pm 5\%$  accuracy limit is seen. For

reference materials, however, careful determination of the ratio of the net heat of combustion to the oxygen-fuel stoichiometric mass ratio makes this source of uncertainty substantially less.

13.5.2 Some materials appear to perform differently in this test method than they would be expected to perform in actual practice. In particular, this test method has a distinct bias when testing materials that melt and drip during the fire test method. Observe such materials with particular care during testing for physical effects capable of influencing test results.

## 14. Keywords

14.1 effective specific heat; effective thermal conductivity; emissivity; heat release rate; ignitability; intermediate scale calorimeter; mass loss rate; oxygen consumption method; smoke release rate; surface temperature

## ANNEXES

### (Mandatory Information)

#### A1. DESIGN OF EXHAUST SYSTEM

##### A1.1 Design of Hood and Exhaust Duct

NOTE A1.1—Symbols are explained in A4.5.

A1.1.1 Collect the combustion gases from the burning specimen by means of a hood. A system is described below that has been tested in practice and proven to fulfill the specifications given in this test method.

A1.1.2 The following bottom dimensions of the hood have been found satisfactory: 3.1 by 2.4 m, with a height of the hood

itself of 1.0 m, see Fig. 5. A vertical skirt on the hood will help ensure all the fire gases are collected at the least duct flow. The hood feeds into a plenum having a 0.9 by 0.9 m cross sectional area. The plenum has a height of 0.9 m. The maximum acceptable plenum height is 1.8 m, depending on building constraints. A system with different dimensions is acceptable, provided equivalence has been demonstrated. Design and manufacture the hood so that no leakage exists.

A1.1.3 In the plenum chamber, it has been found that the

incorporation of two plates approximately 0.5 by 0.9 m in size, see Fig. 5, is a satisfactory way to increase mixing of the combustion gases. Alternative gas mixing methods are acceptable, if equivalence has been demonstrated.

A1.1.4 If a laser is used for smoke measurement, a suitable means of mounting it together with the combustion gas sampling probes is shown in Fig. A1.1.

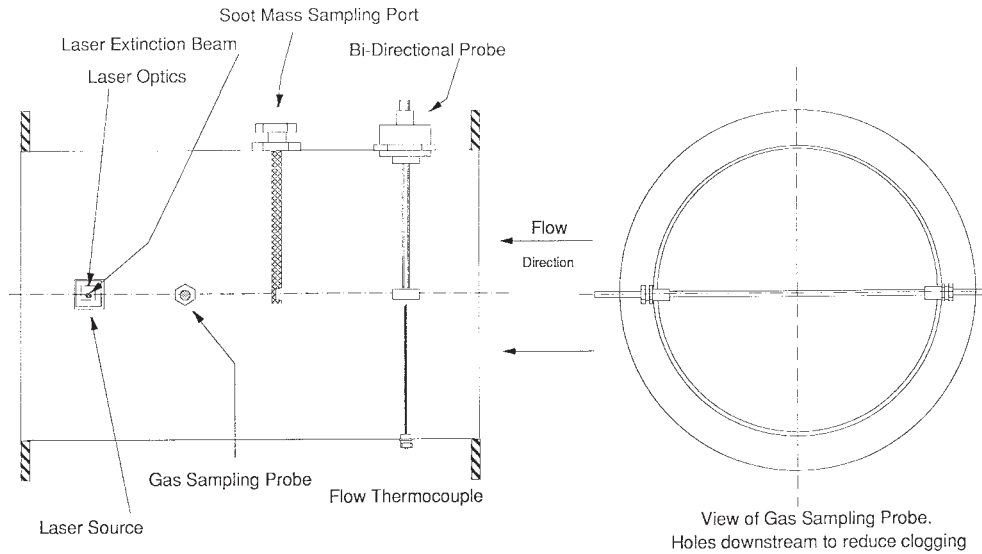

**FIG. A1.1 Laser Beam and Other Instrumentation in Exhaust Duct**

A1.1.5 Connect an exhaust duct to the plenum chamber. The inner diameter of the exhaust duct is 0.4 to 1.0 m. To facilitate flow measurements, guide vanes, if needed are located at both ends of the exhaust duct, Fig. 5. Alternatively, the rectilinear part of the exhaust duct must have such a length that a fully developed flow profile is established at the point of measurement. Connect the exhaust duct to an evacuation system.

A1.1.6 Design the capacity of the evacuation system so as to

exhaust minimally all combustion gases leaving the specimen. This requires an exhaust capacity of at least  $2.7 \text{ kg s}^{-1}$  (about  $8000 \text{ m}^3 \text{ h}^{-1}$  at standard atmospheric conditions) corresponding to a driving under pressure of about 2 kPa at the end of the duct. Provide a means to control the exhaust flow from about  $0.5 \text{ kg s}^{-1}$  up to maximum flow as stated above during the test process. Ensure that the measurement system has sufficient

sensitivity for measuring low rates of heat release. Mixing vanes in the duct are an adequate means of solving the problem if concentration gradients are found to exist.

A1.1.7 An alternative exhaust system design is acceptable if it is shown to produce equivalent results. Equivalency is demonstrated by meeting the calibration requirements under Section 9. Exhaust system designs based on natural convection are unacceptable.

**A2. INSTRUMENTATION IN EXHAUST DUCT**

**A2.1 Flow Measurement**

A2.1.1 One technique for measuring the flow is a bidirectional probe located at the center line of the duct. The probe shown in Fig. A2.1 consists of a stainless steel cylinder 44 mm long and with an inner diameter of 22 mm. The cylinder has a solid diaphragm in the center, dividing it into two chambers. The pressure difference between the two chambers is measured by a differential pressure transducer.

A2.1.2 Use a differential pressure transducer with an accuracy of at least  $\pm 0.25 \text{ Pa}$  and of the capacitance type. A suitable range of measurement is 0 to 150 Pa.

A2.1.3 Place one thermocouple within 152 mm of the bidirectional probe. Use an Inconel sheathed thermocouple, type K Chromel-Alumel. The wire gage shall be in the range 24 AWG (0.51 mm diameter) to 30 AWG (0.36 mm diameter). Place the thermocouple wire, within 13 mm of the bead, along expected isotherms to minimize conduction errors. Use an

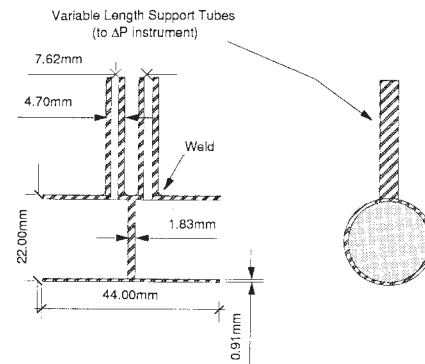

**FIG. A2.1 Bidirectional Probe**

insulation between the Chromel and Alumel wires that is stable to at least  $1100^\circ\text{C}$ . Ensure that the thermocouple does not disturb the flow pattern around the bidirectional probe.

## A2.2 Sampling Line

A2.2.1 Locate the sampling probe in a position where the exhaust duct flow is uniformly mixed. Construct the probe with a cylindrical cross section so as to minimize disturbance of the air flow in the duct. Collect the combustion gas samples across the entire diameter of the exhaust duct (see Fig. A2.2).

A2.2.2 Remove the particulates contained in the combustion gases with inert filters, to the degree required by the gas analysis equipment. Carry out the filtering procedure in more than one step. Cool the combustion gas mixture to a maximum of 4°C. The combustion gas samples taken to each analyzer shall be completely dried.

A2.2.3 Transport the combustion gases by a pump. Use a pump that does not allow the gases to contact oil, grease, or similar products, all of which can contaminate the gas mixture. A diaphragm pump (coated with polytetrafluoroethylene) is suitable. Alternate pumps shown to have the same effect are acceptable, but they have often been shown to need frequent replacement.

A2.2.4 Suitable sampling probes are shown in Fig. A2.2, Fig. A2.3, and Fig. A2.4. These sampling probes are of the bar and cross type. Ring type sampling probes are also acceptable, although they do not collect gas samples across the full diameter of the duct. Turn the intake of the sampling probe downstream to avoid soot clogging the probe.

A2.2.5 A suitable pump has a capacity of 10 to 50 L min<sup>-1</sup> kPa (minimum), as gas analysis instrument consumes about 1 L min<sup>-1</sup>. A pressure differential of at least 10 kPa, as generated by the pump, reduces the risk of smoke clogging of the filters.

A2.2.6 Install a soot filter, capable of removing all particles >25 µm in size.

A2.2.7 A refrigerated column is the most successful approach to cool and dry the gases. Provide a drain plug to remove the collected water from time to time. Alternative devices are also acceptable.

A2.2.8 If carbon dioxide is to be removed, use carbon dioxide removal media, as indicated in Fig. 6.

## A2.3 Combustion Gas Analysis

A2.3.1 *Oxygen Concentration*—Use an oxygen analyzer, meeting the specifications under 6.4.9.2, preferably of the paramagnetic type.

A2.3.2 *Carbon Monoxide and Dioxide Concentration*—

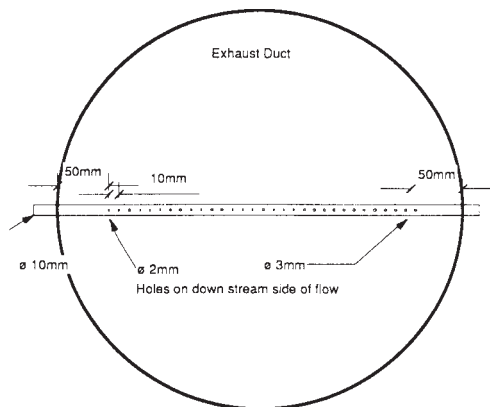

FIG. A2.2 Horizontal Gas Sampling Probe

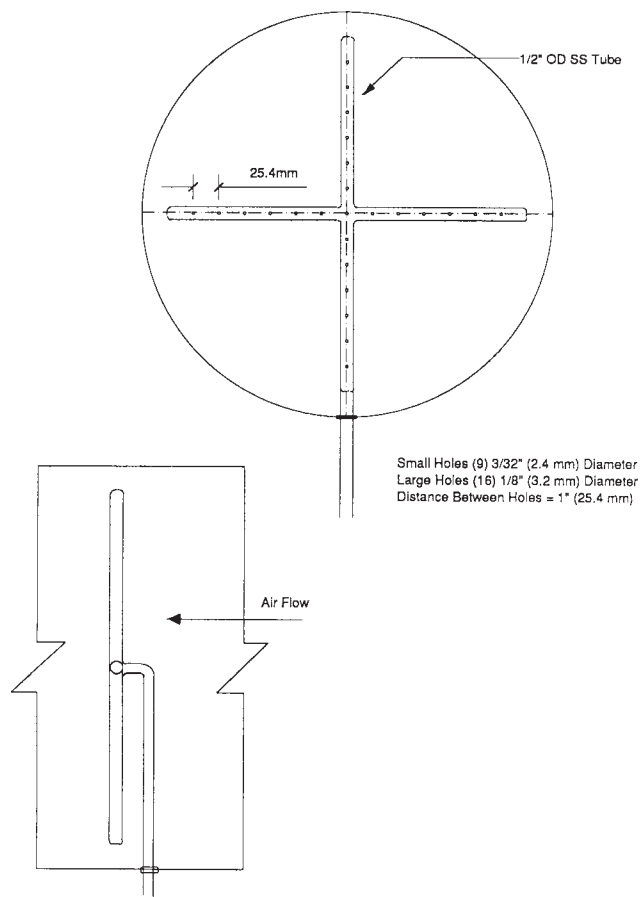

FIG. A2.3 Cross Type Sampling Probe

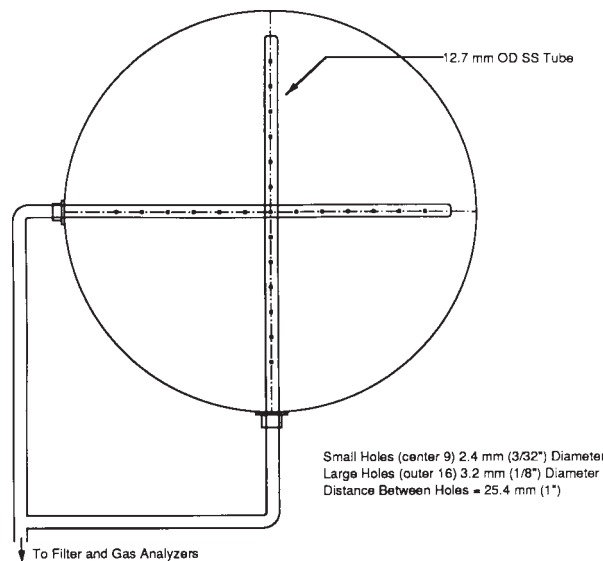

FIG. A2.4 Cross Type Gas Sampling Probe

Analyzers found suitable are nondispersive infrared analyzers. See Guide E 800.

A2.3.3 *Other Combustion Gases*—Use Guide E 800 for details of suitable analyzers when the concentrations of other combustion gases, such as water, total hydrocarbon, nitrogen oxide, hydrogen cyanide, or hydrogen chloride, are to be measured, for special purposes.

A2.3.4 *Time Shift*—Gas concentration measurements require the use of appropriate time shifts in order to account for gas transit time within the sampling system.

#### **A2.4 Smoke Obscuration**

##### *A2.4.1 White Light System:*

A2.4.1.1 One suitable light measuring system based on white light has the following components: a lamp, plano convex lenses, an aperture, a photocell, and an appropriate power supply. Mount lenses, lamp, and photocell inside two housings, located on the exhaust duct, diametrically opposite each other. It has been found that a system consisting solely of a white light and a photocell, along the exhaust duct, across from each other and at an angle to the vertical, is satisfactory in some cases.

A2.4.1.2 Use a lamp of the incandescent filament type, which operates at a color temperature of  $2900 \pm 100$  K. Supply the lamp with stabilized direct current, stable within  $\pm 0.2$  % (including temperature, short term and long term stability). Center the resultant light beam on the photocell.

A2.4.1.3 Select the lens system such that the lens  $L_2$ , according to Fig. 7, has a diameter,  $d$ , chosen with regard to the focal length,  $f$ , of  $L_2$  so that  $d/f \geq 0.04$ .

A2.4.1.4 Place the aperture in the focus of lens  $L_2$  according to Fig. 7.

A2.4.1.5 Use a detector with a spectrally distributed response according to the CIE photopic curve and linear within 5 % over an output range of at least 3.5 decades. Check this linearity over the entire range of the instrument periodically with calibrated optical filters.

A2.4.1.6 The system described as follows is an example of a light measuring system that has been found to be satisfactory: (1) *lenses*—Plano convex: diameter 40 mm, focal length 50 mm; (2) *lamp*—Osram Halo Stars, 64410, 6 V, 10 W, or equivalent; (3) *photocell*—United Detector Technology, PIN 10 AP, or equivalent; and (4) *voltage supply*—Gresham Lion Ltd, Model G  $\times$  012, or equivalent.

A2.4.1.7 Design a system that is easily purged against soot deposits. The use of holes in the periphery of the two housings is a means of achieving this objective.

A2.4.2 *Laser System*—An acceptable alternate system for measurements of smoke obscuration uses a laser beam. An 0.5 to 2.0 mW helium-neon laser beam is projected across the exhaust duct. Couple the two halves of the device rigidly together (see Fig. 8).

### **A3. CONSIDERATIONS FOR HEAT RELEASE MEASUREMENTS**

#### **A3.1 Measurement of Rate of Heat Release by Oxygen Consumption**

A3.1.1 *Introduction*—In 1917, Thornton (2) showed that for a large number of organic fuels, a more or less constant net amount of heat is released per unit of oxygen consumed for complete combustion. Huggett (3) obtained an average value for this constant of 12.1 MJ/kg of  $O_2$ . It is appropriate to use this value for practical applications; it is accurate, with very few exceptions, to within  $\pm 5$  %.

A3.1.2 Thornton's rule indicates that it is sufficient to measure the oxygen consumed in a combustion system in order to determine the net heat released. This is particularly useful for full-scale fire test applications. For example, for compartment fires, the oxygen consumption technique is much more accurate and easier to implement than methods based on measuring all the terms in a heat balance of the compartment.

A3.1.3 Perhaps the first application of the  $O_2$  consumption principle in fire research was by Parker (10) using Test Method E 84 tunnel test. Later, Sensenig applied it to an intermediate scale room test (7). During the late seventies and early eighties, the  $O_2$  consumption technique was refined at the National Institute for Standards and Technology (NIST, formerly National Bureau of Standards). A paper by Parker (11) gives equations to calculate rate of heat release by  $O_2$  consumption for various applications. The technique is now used extensively in many laboratories all over the world, both in bench-scale (12) and full-scale (Proposal P147 and (13)) fire test applications.

A3.1.4 The objective of this section is to provide a comprehensive set of equations and guidelines to determine the rate of heat release in ICAL fire tests based on the  $O_2$  consumption

principle. The approach followed here is somewhat different from Parker (11) as the emphasis is on intermediate-scale fire test applications and the use of volumetric flows is avoided. Volumetric flows require specification of temperature and pressure. Various investigators have used different combinations of reference pressure and temperature. This leads to confusion, which is greatly minimized if mass flows are used.

A3.1.5 The basic requirement is that all combustion products be collected in a hood and removed through an exhaust duct. At a distance downstream of the hood sufficient for adequate mixing, both flow and composition of the combustion gases are measured. It is assumed here that it is not possible to measure the air flow into the system, as this is generally the case for full-scale fire tests. The differences in treatment and equations to be used are mainly due to the extent to which combustion gas analysis is made. At least  $O_2$  shall be measured. However, heat release rate measurements will be more accurate by measuring  $CO_2$  and CO additionally.

A3.1.6 It must be emphasized that the analysis is approximate. The following list describes the main simplifying assumptions made:

A3.1.6.1 The amount of energy released by complete combustion per unit of oxygen consumed is taken as:  $E = 12.1$  MJ/kg of  $O_2$ .

A3.1.6.2 All combustion gases are considered to behave as ideal gases, in other words one mole of any gas is assumed to occupy a constant volume at the same pressure and temperature.

A3.1.6.3 Incoming air consists of  $O_2$ ,  $CO_2$ ,  $H_2O$ , and  $N_2$ . All "inert" gases, which do not take part in the combustion reaction, are lumped into the nitrogen.

A3.1.6.4 O<sub>2</sub>, CO<sub>2</sub>, and CO are measured on a dry basis, in other words water vapor is removed from the specimen before combustion gas analysis measurements are made.

A3.1.7 In the analysis to follow, initial emphasis will be placed on the flow measurement. Equations to calculate flow are applicable, unless otherwise indicated, irrespective of the configuration of the combustion gas analysis system. In subsequent sections, distinction is made between various combustion gas analyzer combinations.

### A3.2 Flow Measurements

A3.2.1 Mainly two techniques are used to measure mass flow in the exhaust duct of ICAL fire tests.

A3.2.2 The first technique measures mass flow by the pressure drop across, and temperature at, an orifice plate (see Eq A4.1). If the test is conducted within a narrow range of conditions, the orifice plate coefficient,  $C$ , is approximately constant. Determine the value of the orifice plate coefficient using a gas burner calibration or an alternative method that provides equivalent results. However, if flows are varied during a test or if temperature changes are considerable, the effects on  $C$  of the Reynolds number and pressure at the downstream side of the orifice plate must be taken into account. Information on such corrections and on various design options (for example location of the pressure taps) are found in Ref (14).

A3.2.3 The other technique is to measure velocity at one point in the duct, usually along the center line. The flow is then calculated using a predetermined shape of the velocity profile in the duct. The latter is obtained by measuring velocity at a sufficient number of representative points over the diameter or cross section of the duct prior to any fire tests. Detailed procedures to obtain this profile are described in (15). Usually, conditions in intermediate-scale fire tests are such that the flow in the duct is turbulent, resulting in a shape factor  $k_c$  (equals ratio of the average velocity to the velocity along the centerline) close to 1.

A3.2.4 Due to considerable soot production in many fires, pitot static tubes cannot be used because of the potential for clogging of the holes. In order to deal with this problem, a more robust bidirectional probe was designed by McCaffrey and Heskestad (16). This involves measuring the differential pressure across the probe and the centerline velocity (see Eq A4.2), and is valid in the range of Reynolds numbers,  $Re$ :  $40 < Re < 3800$ . In many intermediate-scale first test applications, duct diameter and flow are such that the Reynolds number is:  $Re > 3800$ . In this case  $f(Re)$  is taken as a constant (1.08), which greatly simplifies the calculations. This equation (see Eq A4.2) is preferred to Eq A4.1 for intermediate scale measurements of heat release rate. Further details of this and of all other calculations discussed in this annex are found in a paper by Janssens (17). For additional details, see also ISO 9705.

### A3.3 Rate of Heat Release Measurement if Only Oxygen is Measured

A3.3.1 In this case all water vapor and CO<sub>2</sub> are eliminated by the use of appropriate filtering media. This leads to the assumption that the specimen combustion gas only consists of O<sub>2</sub> and N<sub>2</sub>. This is approximately true provided CO production

is negligible, which is usually the case due to the abundant availability of oxygen. As the composition of the incoming air is unlikely to change during a test, and as the temperatures in building fires are usually not high enough to generate noticeable amounts of nitrogen oxides by nitrogen fixation, the mole fraction of O<sub>2</sub> in the air as measured by the analyzer prior to a test can be written on the basis of O<sub>2</sub> and N<sub>2</sub> exclusively. The mole fraction of O<sub>2</sub> in the exhaust combustion gases, as measured by the oxygen analyzer, can be written likewise. As nitrogen is conserved and does not participate in the combustion reactions, the equations are derived on the basis of its conservation.

A3.3.2 In this case the rate of heat released (in kW) is calculated as a function of the heat released per unit of oxygen consumed ( $E$ , 12.1 MJ/kg of O<sub>2</sub>), the ratio of the molecular weight of oxygen ( $M_{O_2}$ , 32.0 kg/kmol) and molecular weight of the incoming air ( $M_a$ , generally taken as 28.97 kg/kmol) and the mass flow of the incoming air (in kg/s). The flow measured is that of the smoke within the exhaust duct and not that of the incoming air. In order to find a relation between the two, it is necessary to define the oxygen depletion factor. The oxygen depletion factor is the fraction of the incoming air which is fully depleted of its oxygen (see Eq A4.4). It has been demonstrated (see appendix in Test Method E 1354), that the rate of heat release is a function of  $E$ ,  $M_{O_2}$ ,  $M_a$ , and the oxygen depletion factor, plus the factor, plus the expansion factor.

A3.3.3 The expansion factor has to be assigned and a recommended value is 1.105, the value for methane. The value for propane is 1.084, carbon in dry air is 1.0 and hydrogen is 1.21.

A3.3.4 The resulting equation, A4.5, is expected to be accurate to within  $\pm 5\%$  provided combustion is complete and all carbon is converted to CO<sub>2</sub>. Errors will be larger if CO or soot production is considerable or if a significant amount of the combustion products are other than CO<sub>2</sub> and H<sub>2</sub>O. It is unlikely that these errors will be of concern for the ICAL tests since O<sub>2</sub> is not limited.

### A3.4 Rate of Heat Release Measurement if Oxygen and Carbon Dioxide are being Measured

A3.4.1 This case is similar to that covered in A3.3. It is now assumed that only water vapor is trapped before the specimen reaches the combustion gas analyzers. Again, the equations are derived on the basis of conservation of N<sub>2</sub>. The mole fraction of CO<sub>2</sub> in the incoming air is taken to be 440 ppm. A new equation is now needed, of course, for the oxygen depletion factor: Eq A4.7. Again the equation for rate of heat release (see Eq A4.5) is accurate to within  $\pm 5\%$  provided combustion is complete and all carbon is converted to CO<sub>2</sub>.

### A3.5 Rate of Heat Release Measurement if Oxygen, Carbon Dioxide, and Carbon Monoxide are being Measured

A3.5.1 This case reverts to that covered in A3.4 if CO production is negligible. Taking CO into account, however, changes the equations. It means that a new oxygen depletion factor is required, Eq A4.8, as well as a new rate of heat release equation altogether, Eq A4.9.



### A3.6 Calculation of Heat Released by Igniting Fuel

A3.6.1 Part of the oxygen depletion in the exhaust duct is due to the combustion of the radiant panel fuel. This part must be subtracted from the total oxygen depletion in order to determine the net rate of heat release of the specimen.

### A3.7 Conclusions

A3.7.1 Depending on the configuration of combustion gas analyzers and the type of flow measurement, one of the following procedures shall be used to calculate rate of heat release:

A3.7.2 *Case 1—Only O<sub>2</sub> is Measured:*

A3.7.2.1 Calculate the mass flow of the exhaust combustion bases,

A3.7.2.2 Calculate the oxygen depletion factor, and

A3.7.2.3 Calculate the rate of heat release.

A3.7.3 *Case 2—Both O<sub>2</sub> and CO<sub>2</sub> are Measured:*

A3.7.3.1 Calculate the mass flow of the exhaust combustion gases as in A3.7.2,

A3.7.3.2 Calculate the new oxygen depletion factor, and

A3.7.3.3 Calculate the new rate of heat release.

A3.7.4 *Case 3—O<sub>2</sub> and CO<sub>2</sub> and CO are Measured:*

A3.7.4.1 Calculate the mass flow of the exhaust combustion gases as in A3.7.2,

A3.7.4.2 Calculate the new oxygen depletion factor, and

A3.7.4.3 Calculate the new rate of heat release.

A3.7.5 The following numerical values are recommended for use in the equations:

A3.7.5.1 *Energies*— $E = 13.1$  MJ/kg of O<sub>2</sub>,  $E_{CO} = 17.6$  MJ/kg of O<sub>2</sub>.

A3.7.5.2 *Molecular Weights*— $M_a = 29$  kg/kmol (Cases 1, 2, and 3),  $M_{CO} = 28$  kg/kmol,  $M_{CO_2} = 44$  kg/kmol,  $M_{dry} = 29$  kg/kmol,  $M_e = 29$  kg/kmol (Cases 1, 2, and 3),  $M_{H_2O} = 18$  kg/kmol, and  $M_{N_2} = 28$  kg/kmol,  $M_{O_2} = 32$  kg/kmol.

A3.7.5.3 *Expansion factor* = 1.105 (Cases 1, 2, and 3).

A3.7.6 If a CO<sub>2</sub> analyzer is used, this eliminates the need for removal of CO<sub>2</sub> from the combustion gas specimen. This is mainly of practical importance as the scrubbing agent used to remove CO<sub>2</sub> usually requires careful handling and is rather expensive. If a significant amount of CO is produced (for example at or beyond flashover in ventilation controlled room fires), accuracy of the rate of heat release measurement is improved if CO is measured.

A3.7.7 The presence of a water vapor analyzer simplifies the analysis and improves accuracy even more. Unfortunately, implementation of a water vapor analyzer is not straightforward because sampling lines, filters, etc. must be heated to avoid condensation. Thus, the use of a water vapor analyzer precludes the need to estimate the expansion factor. However, for this test method, the use of water analyzers is not recommended.

## A4. MEASUREMENT EQUATIONS

### A4.1 Rate of Heat Release

A4.1.1 *Flow:*

A4.1.1.1 *Pressure Drop Measurement (Eq A4.1):*

$$\dot{m}_e = C^* \sqrt{\left[\frac{\Delta p}{T_e}\right]} \quad (\text{A4.1})$$

A4.1.1.2 *Velocity Measurement (Eq A4.2):*

$$\dot{m}_e = 26.54^* \frac{A^* k_c^*}{f(Re)} \sqrt{\left[\frac{\Delta p}{T_e}\right]} \quad (\text{A4.2})$$

The preferred measurement method uses Eq A4.1. If Eq A4.2 is used, determine  $k_c$  daily, by calibration.

A4.1.1.3 The function of the Reynolds number  $f(Re)$  has been described, by McCaffrey and Heskestad (16), as responding to Eq A4.3:

$$f(Re) = 1.533 - 1.366 \times 10^{-3} Re^+ + 1.688 \times 10^6 Re^2 - 9.705 \times 10^{11} Re^3 + 2.555 \times 10^{-13} Re^4 - 2.484 \times 10^{-17} Re^5 \quad (\text{A4.3})$$

A4.1.2 *Case 1—Only O<sub>2</sub> is Measured:*

A4.1.2.1 Calculate the mass flow according to the equations in A4.1.1 (Eq A4.1 and Eq A4.2) and the oxygen depletion factor according to Eq A4.4:

$$\Phi = \frac{X_{O_2}^{A^*} - X_{O_2}^A}{[1 - X_{O_2}^A]^* X_{O_2}^{A^*}} \quad (\text{A4.4})$$

Then, calculate the rate of heat release ( $\dot{q}$ ) according to Eq A4.5:

$$\dot{q} = E^* \frac{M_{O_2}^* \Phi}{M_a [1 + \Phi^*(\alpha - 1)]} \dot{m}_e^* X_{O_2}^{A^*} \quad (\text{A4.5})$$

A4.1.2.2 If only O<sub>2</sub> is measured, Eq A4.5 simplifies to Eq A4.6:

$$\dot{q} = E^* 1.10^* C \sqrt{\left[\frac{\Delta p}{T_e}\right]} \left[ \frac{X_{O_2}^{A^*} - X_{O_2}^A}{1.105 - 1.5^* X_{O_2}^A} \right] \quad (\text{A4.6})$$

A4.1.3 *Case 2—Only O<sub>2</sub> and CO<sub>2</sub> are Measured:*

A4.1.3.1 Calculate the mass flow according to the equations in A4.1.1 (Eq A4.1 and Eq A4.2) and the oxygen depletion factor in accordance with Eq A4.7:

$$\Phi = \frac{X_{O_2}^{A^*} [1 - X_{CO_2}^A] - X_{O_2}^A [1 - X_{CO_2}^{A^*}]}{X_{O_2}^{A^*} [1 - X_{O_2}^A - X_{CO_2}^A]} \quad (\text{A4.7})$$

Calculate the rate of heat release in accordance with the same equation as in A4.1.2 (Eq A4.5).

A4.1.4 *Case 3—O<sub>2</sub>—and CO<sub>2</sub> and CO are Measured:*

A4.1.4.1 Calculate the mass flow in accordance with the equations in A4.1.1 (Eq A4.1 or Eq A4.2), the moisture content of the incoming atmosphere in accordance with the Eq in A4.1.2 (Eq A4.5) and the oxygen depletion factor in accordance with Eq A4.8).

$$\Phi = \frac{X_{O_2}^{A^o} [1 - X_{CO_2}^A - X_{CO}^A] - X_{O_2}^A [1 - X_{CO_2}^{A^o}]}{X_{O_2}^{A^o} [1 - X_{O_2}^A - X_{CO_2}^A - X_{CO}^A]} \quad (\text{A4.8})$$

A4.1.4.2 Finally calculate the rate of heat release in accordance with Eq A4.9:

$$\dot{q} = \left[ E \cdot \Phi - [E_{CO} - E] \cdot \frac{1 - \Phi}{2} \cdot \frac{X_{CO_2}^A}{X_{O_2}^A} \right] \cdot \frac{M_{O_2}}{M_a} \cdot \frac{\dot{m}_e}{1 + \Phi(\alpha - 1)} \cdot X_{O_2}^{A^o} \quad (\text{A4.9})$$

## A4.2 Total Heat Release Equations

A4.2.1 Determine the total heat released during combustion,  $q$ , by summation as follows:

$$q = \sum_i \dot{q}_i(t) \Delta t \quad (\text{A4.10})$$

where the summation begins with the first reading after exposure and continues until the final reading of the test.

## A4.3 Smoke Measurement Equations

A4.3.1 *Optical Density (OD) (Eq A4.11):*

$$OD = \log[I_0/I] \quad (\text{A4.11})$$

A4.3.2 *Extinction Coefficient ( $k$ ) (Eq A4.12):*

$$k = (1/L_p) \cdot \ln[I_0/I] \quad (\text{A4.12})$$

A4.3.2.1 The volumetric flow is calculated as the product of the mass flow and the density of air, at the corresponding temperature. Thus, both the volumetric flow and the density of air must undergo temperature corrections. The volumetric duct flow  $\dot{V}$  is adjusted because it is measured in the exhaust duct, but required at the temperature near the photodetector, as shown in (Eq A4.13):

$$\dot{V}_s = \dot{V}_e \cdot \left( \frac{T_s}{T_e} \right) \quad (\text{A4.13})$$

A4.3.2.2 The density of air is adjusted between the literature value, measured at 273.15 K, and the value at the temperature in the exhaust duct, as shown in (Eq A4.14):

$$\rho = \rho_0 \cdot \frac{273.15}{T_e} \quad (\text{A4.14})$$

A4.3.2.3 Then, the final equation for the volumetric flow is Eq A4.15:

$$\dot{V}_s = \frac{\dot{m}_e \cdot T_e}{\rho_0 \cdot 273.15} \quad (\text{A4.15})$$

A4.3.2.4 Rate of smoke release (RSR) is defined by Eq A4.16:

$$RSR = [\dot{V}_s \cdot k] \quad (\text{A4.16})$$

A4.3.2.5 Total smoke released (TSR) is defined by Eq A4.17:

$$TSR = \int RSR dt \quad (\text{A4.17})$$

## A4.4 Gas Yield Measurement Calculations

A4.4.1 Calculate the gas yields ( $f$ ) using the following equation (Eq A4.18):

$$f_x = \frac{\int \text{mass flow of gas}_x dt}{\text{mass loss of specimen}} \quad (\text{A4.18})$$

A4.4.2 The numerator in Eq A4.18 is calculated by summing the product of the fraction of combustion gas by the total mass flow, measured at each scan, multiplying it by the total time period involved and dividing by the number of scans, as shown in Eq A4.19:

$$f_x = \frac{(\sum_i ([x]_i \cdot \dot{m}_{e(i)} \cdot \Delta t_i)) \cdot 0.001 \cdot \frac{M_x}{M_a}}{\text{mass loss of specimen}} \quad (\text{A4.19})$$

A4.4.3 In this equation,  $[x]$ , the concentration of gas  $x$ , is expressed in kg/kg,  $\dot{m}_e$ , the mass flow, calculated by Eq A4.1 or Eq A4.2, is expressed in kg/s,  $M_x$  is the molecular weight of gas species  $x$ ,  $\Delta t$  is the scan period, and mass loss of specimen is the mass lost over the period over which the gas yield is calculated, and is expressed in g, with 0.001 a conversion factor, to account for the unit changes.

A4.4.4 Report gas concentrations on a dry gas basis, unless water concentrations are being measured.

## A4.5 Symbols

A4.5.1  $\dot{m}_e$ —Mass flow in exhaust duct (kg/s).

A4.5.2  $C$ —Orifice plate coefficient ( $\text{kg}^{1/2} \text{m}^{1/2} \text{K}^{1/2}$ ).

A4.5.3  $\Delta p$ —Pressure drop across the orifice plate or bidirectional probe (Pa).

A4.5.4  $T_e$ —Combustion gas temperature at the orifice plate (K).

A4.5.5  $A$ —Cross sectional area of duct ( $\text{m}^2$ ).

A4.5.6  $k_c$ —Velocity profile shape factor (nondimensional).

A4.5.7  $f(Re)$ —Reynolds number correction.

A4.5.8  $q$ —Total heat released (MJ).

A4.5.9  $\dot{q}$ —Rate of heat release (kW).

A4.5.10  $E$ —Net heat released for complete combustion, per unit of oxygen consumed (13.1 MJ/kg  $\text{O}_2$ ).

A4.5.11  $\Delta t$ —Sampling time interval(s).

A4.5.12  $t$ —Time(s).

A4.5.13  $\alpha$ —Combustion expansion factor (nondimensional; normally a value of 1.105).

A4.5.14  $X_{O_2}^{A^o}$ —Measured mole fraction of  $\text{O}_2$  in incoming air (nondimensional).

A4.5.15  $X_{O_2}^A$ —Measured mole fraction of  $\text{O}_2$  in exhaust flow (nondimensional).

A4.5.16  $X_{CO_2}^{A^o}$ —Measured mole fraction of  $\text{CO}_2$  in incoming air (nondimensional).

A4.5.17  $X_{CO_2}^A$ —Measured mole fraction of  $\text{CO}_2$  in exhaust flow (nondimensional).

A4.5.18  $X_{CO}^{A^o}$ —Measured mole fraction of CO in incoming air (nondimensional).

A4.5.19  $X_{CO}^A$ —Measured mole fraction of CO in exhaust flow (nondimensional).

A4.5.20  $E_{CO}$ —Net heat released for incomplete combustion, per unit of CO consumed.

A4.5.21  $M_{dry}$ —Molecular weight of dry air (29 kg/kmol).  
 A4.5.22  $M_a$ —Molecular weight of incoming air (kg/kmol).  
 A4.5.23  $M_{O_2}$ —Molecular weight of oxygen (32 kg/kmol).  
 A4.5.24  $\dot{m}_e - C (\Delta p/T_e)^{1/2}$  (mass flow, by measurement of pressure drop, in kg/s, according to Eq A4.1).  
 A4.5.25  $\dot{m}_e - (26.54 \times A \times k_c/f (Re)) \times (\alpha/T)^{1/2}$  (mass flow, by measurement of velocity drop, in kg/s, according to Eq A4.2).  
 A4.5.26  $I_o$ —Light intensity for a beam of parallel light rays, measured in a smoke free environment, with a detector having the same spectral sensitivity as the human eye and reaching the photodetector.  
 A4.5.27  $I$ —Light intensity for a parallel light beam having traversed a certain length of smoky environment and reaching photodetector.  
 A4.5.28  $OD$ —Optical density (nondimensional).  
 A4.5.29  $k$ —Extinction coefficient (1/m).  
 A4.5.30  $L_p$ —Light path length of beam through smoky environment (m).  
 A4.5.31  $T_s$ —Duct temperature (near photodetector) (K).  
 A4.5.32  $\dot{V}_e$ —Volumetric flow in exhaust duct (at measuring location of mass flow) ( $m^3/s$ ).

A4.5.33  $\dot{V}_s$ —Volumetric flow at location of smoke meter (value adjusted for smoke measurement calculations) ( $m^3/s$ ).  
 A4.5.34  $\rho_o$ —Density of air at 273.15 K: 1.293 ( $kg/m^3$ ).  
 A4.5.35  $\rho$ —Density of air at the temperature in exhaust duct ( $kg/m^3$ ).  
 A4.5.36  $RSR$ —Rate of smoke release ( $m^2/s$ ).  
 A4.5.37  $TSR$ —Total smoke release ( $m^2$ ).  
 A4.5.38  $\phi$ —Oxygen depletion factor (nondimensional).  
 A4.5.39  $f_x$ —Yield of gas  $x$  (kg/kg).  
 A4.5.40  $[x]$ —Concentration of gas  $x$  (kg/kg).  
 A4.5.41  $M_e$ —Molecular weight of exhaust gases (kg/kmol).  
 A4.5.42  $M_{H_2O}$ —Molecular weight of water (kg/kmol).  
 A4.5.43  $M_{N_2}$ —Molecular weight of nitrogen (kg/kmol).  
 A4.5.44  $M_{CO_2}$ —Molecular weight of carbon dioxide (kg/kmol).  
 A4.5.45  $M_{CO}$ —Molecular weight of carbon monoxide (kg/kmol).  
 A4.5.46  $m$ —Specimen mass (kg).  
 A4.5.47  $m_f$ —Final specimen mass (kg).  
 A4.5.48  $m_i$ —Initial specimen mass (kg).  
 A4.5.49  $\Delta h_{c,eff}$ —Effective heat of combustion (kJ/kg).

## A5. MASS LOSS RATE AND EFFECTIVE HEAT OF COMBUSTION CALCULATIONS

### A5.1 Mass Loss Rate and Effective Heat of Combustion

A5.1.1 Compute the required mass loss rate,  $-dm/dt$ , at each time interval using five-point numerical differentiation. The equations to be used are as follows:

A5.1.2 For the first scan ( $i = 0$ ):

$$-\left[\frac{dm}{dt}\right]_{i=0} = \frac{25m_0 - 48m_1 + 36m_2 - 16m_3 + 3m_4}{12\Delta t} \quad (A5.1)$$

A5.1.3 For the second scan ( $i = 1$ ):

$$-\left[\frac{dm}{dt}\right]_{i=1} = \frac{10m_0 - 3m_1 - 18m_2 + 6m_3 - m_4}{12\Delta t} \quad (A5.2)$$

A5.1.4 For any scan for which  $1 < i < n - 1$  (where  $n$  = total number of scans):

$$-\left[\frac{dm}{dt}\right]_i = \frac{-m_{i-2} + 8m_{i-1} - 8m_{i+1} + m_{i+2}}{12\Delta t} \quad (A5.3)$$

A5.1.5 For the next to last scan ( $i = n - 1$ ):

$$-\left[\frac{dm}{dt}\right]_{i=n-1} = \frac{-10m_n - 3m_{n-1} + 18m_{n-2} - 6m_{n-3} + m_{n-4}}{12\Delta t} \quad (A5.4)$$

A5.1.6 For the last scan ( $i = n$ ):

$$-\left[\frac{dm}{dt}\right]_{i=n} = \frac{-25m_n + 48m_{n-1} - 36m_{n-2} + 16m_{n-3} - 3m_{n-4}}{12\Delta t} \quad (A5.5)$$

A5.1.7 Determine the average effective heat of combustion as follows:

$$\Delta h_{c,eff} = \frac{\sum_i q_i(t)\Delta t}{m_i - m_f} \quad (A5.6)$$

With the summation taken over the entire test length. The time-varying value is also determined as follows:

$$\Delta h_{c,eff}(t) = \frac{q_i(t)}{-(dm/dt)} \quad (A5.7)$$

## A6. Procedure for Calculating Analyzer Time Delay

A6.1 This procedure determines the time delay correction for oxygen (and for other gases) used in heat release rate calculations. An instantaneous change in heat release rate is introduced by inserting or igniting a burner underneath the measuring hood and measuring the time required by the gas analyzer to respond to the change. Use a sufficient amount of gas (methane or propane) to cause an oxygen depletion of at least 1%.

A6.2 The preferred technique is to have a burner ignited outside the hood and insert it rapidly, ensuring a "step change" in heat release rate. If this is impractical, ignite the burner under the hood, after having purged it of air so that ignition and the required fuel flow are achieved instantaneously.

A6.3 Record, at intervals of  $\leq 3$  s: duct temperature (with the thermocouple closest to the collection hood), duct oxygen

concentration, average duct volume or mass flow rate and (if they are to be used during tests) duct carbon monoxide and carbon dioxide concentrations.

A6.4 Perform the following sequence a minimum of three times: record baseline data for 3 min (without burning gas flowing), rapidly ignite the gas burner or insert the lit burner, record data for 3 min, rapidly extinguish or remove the burner.

A6.5 Plot duct temperature and oxygen concentration on the same graph, with sufficient detail to be able to interpolate time to the nearest second, temperature to the nearest 5°C and oxygen to the nearest 0.01%. Do the same for carbon oxides, if required, to within 1% of full scale for each gas.

A6.6 Determine the analyzer time delay as shown in A6.1 through A6.4.

A6.6.1 Determine the time at which the duct temperature shows a deflection from the baseline (or previous level), to within 1 s.

A6.6.2 Determine the time at which the gas concentration reaches 50% of its ultimate change over the 3 min period, to within 1 s.

A6.6.3 Record the time difference between the values determined in A6.1 and in A6.2 as the analyzer delay time.

A6.6.4 Calculate the analyzer delay time six times (three involving change from "off" to "on" and three involving change from "on" to "off") and average them to assess the time delay.

## APPENDIX

### (Nonmandatory Information)

#### X1. COMMENTARY

##### X1.1 Introduction

X1.1.1 Rate of heat release is the most important fire quantity associated with a burning object, room, or building. It describes the size of the fire at any time during a specific fire scenario.

X1.1.2 Bench scale test methods like the Cone Calorimeter (see Test Method E 1354) and the Ohio State University Rate of Heat Release Apparatus (see Test Method E 906) have been used for testing materials and to some extent sandwich panels and composites. The resulting rate of heat release (RHR) data have mainly been used in computer fire models. Classifications of building materials and products have also been proposed on the basis of heat release data from the Cone Calorimeter alone or in combination with a large scale fire test.

X1.1.3 However, some materials and especially assemblies can not be successfully tested on a bench-scale apparatus for several reasons. One of the most important limitations is the composition of assemblies. The very small samples used in the bench scale apparatus cannot adequately represent an assembly. Also, other features, like joints of assembly panels, sheets of noncombustible protective materials, cracking, material collapse, melting and spilling of thermoplastic materials, cannot be represented in a bench-scale sample. Neither can these features be mathematically modeled.

X1.1.4 Large-scale tests like a standard room fire test have been successfully used for heat release measurements of assemblies. Attempts to measure heat release from fire endurance furnaces have not been successful. These tests are expensive and time consuming. The new ICAL test method discussed in this test method overcomes most of the problems identified with large and bench scale testing.

X1.1.5 The ICAL was developed between 1989 and 1993 at Weyerhaeuser Fire Technology Laboratory in cooperation with the American Forest and Paper Association (formerly National Forest Products Association). In the years following, several

laboratories have built, or are building, test equipment to conduct this test.

##### X1.2 Factors Affecting Radiant Panel Assembly Performance

X1.2.1 Because the surface temperature of the specimen may change during a test, the surface temperature and, therefore, irradiance from the radiant panel may also change. In order to maintain a constant irradiance, the flow of gas to the radiant panel must be adjusted to compensate for the reradiation from the sample.

X1.2.2 Experience in operating the radiant panel in a relatively small laboratory shows that high heat flow from the radiant panel may increase the temperature of the room and gas plumbing while the radiant panel is operating. This increase in the plumbing temperature will cause the gas temperature and flow to increase also. Therefore, the heat produced by the radiant panel will also change. Such changes may influence the results of the tests of longer duration.

##### X1.3 Ignition Source for the ICAL

X1.3.1 Different ignition sources were examined for use in the ICAL. The desired ignition system should ignite the specimen surface instantaneously as it reaches the ignition temperature. A line pilot burner was positioned near the top of the specimen as a first attempt. Ignition by this mode did not provide for uniform ignition over the whole surface especially at irradiances greater than 30 kW/m<sup>2</sup>. Rather, the flaming ignition was isolated to the burning of the pyrolysis gases above the specimen and did not spread downward over the surface.

X1.3.2 When the pilot line burner was positioned near the bottom of the specimen, they caused localized heating and premature ignition. The rest of the specimen had not reached the ignition temperature that resulted in upward flame spread.

X1.3.3 Spark igniters are used extensively when gas phase ignition is desired. This approach was not suitable for the ICAL



since the width of the sample was quite large and would have required many spark sources near the bottom edge. Even more spark igniters would be required at the top of the specimen for certain assemblies that generate pyrolysis gases near the top of the specimen only.

X1.3.4 Hot wire igniters at the top and bottom of the specimen were determined to be the best solution to the problems mentioned above. The hot wires have performed well in all the tests conducted to date on several different materials and assemblies.

## REFERENCES

- (1) Urbas, J., "Nondimensional Heat of Gasification Measurements in the Intermediate Scale Rate of Heat Release Apparatus," *Fire and Materials*, Vol 17, 1993, pp. 119–123.
- (2) Thornton, W., "The Relation of Oxygen to the Heat of Combustion of Organic Compounds," *Philosophical Magazine and Journal of Science*, Vol 33, No. 196, 1917.
- (3) Huggett, C., "Estimation of Rate of Heat Release by Means of Oxygen Consumption Measurements," *Fire and Materials*, Vol 4, 1980, pp. 61–5.
- (4) Urbas, J., and Parker, W. J., "Surface Temperature Measurements on Burning Wood Specimens in the Cone Calorimeter and the Effect of Grain Orientation," *Fire and Materials*.
- (5) Tran, H. C., and Janssens, M. L., "Wall Corner Fire Tests on Selected Wood Products," *Journal of Fire Sciences*, 9, 1991, pp. 106–124.
- (6) Ostman, B., "Comparison of Smoke Release from Building Products," *Int. Conference of Fire, Control the Heat ... Reduce the Hazard*, London, UK, 24–25, Fire Research Station, UK, Paper 8, October 1988.
- (7) Sensenig, D., "An Oxygen Consumption Technique for Determining the Contribution of Interior Wall Finishes to Room Fires," *Technical Note 1182*, 1980.
- (8) Hirschler, M.M., "An Intermediate Scale Calorimetry Test: ICAL (ASTM E 1623), Precision (Repeatability and Reproducibility) and Applications", M.M. Hirschler, in Fire Retardant Chemicals Association Fall Mtg, Tucson, AZ, Oct. 25–27, 1999, pp. 117–149.
- (9) Urbas, J., Shaw, J., and Luebbbers, J., "Results of Tests Conducted on the Intermediate Scale Calorimeter," August 24, 1993.
- (10) Parker, W., "An Investigation of the Fire Environment in the ASTM E84 Tunnel Test," *NBS Technical Note 945*, 1977.
- (11) Parker, W., "Calculations of the Heat Release Rate by Oxygen Consumption for Various Applications," *NBSIR 812-2427-1*, 1982.
- (12) Babrauskas, V., "Development of the Cone Calorimeter—A Bench-Scale Rate of Heat Release Apparatus Based on Oxygen Consumption," *NBSIR 82-2611*, 1982.
- (13) Babrauskas, V., Lawson, J., Walton, W., and Twilley, W., "Upholstered Furniture Heat Release Rates Measured with the Furniture Calorimeter," *NBSIR 82-2604*, 1983.
- (14) ASME, "Fluid Meters—Their Theory and Applications," *Report of the ASME Committee on Fluid Meters*, H. Bean editor, Sixth Edition, 1971.
- (15) Ower, E., and Pankhurst, R., "The Measurement of Air Flow," *Pergamon Press*, 5th Edition, pp. 112–147, 1977.
- (16) McCaffrey, B., and Heskestad, G., *Combustion and Flame*, Vol 26, 1976, pp. 125–127.
- (17) Janssens, M. L., "Measuring Rate of Heat Release by Oxygen Consumption," *Fire Technology*, 27, 1991, pp. 234–249.

*ASTM International takes no position respecting the validity of any patent rights asserted in connection with any item mentioned in this standard. Users of this standard are expressly advised that determination of the validity of any such patent rights, and the risk of infringement of such rights, are entirely their own responsibility.*

*This standard is subject to revision at any time by the responsible technical committee and must be reviewed every five years and if not revised, either reapproved or withdrawn. Your comments are invited either for revision of this standard or for additional standards and should be addressed to ASTM International Headquarters. Your comments will receive careful consideration at a meeting of the responsible technical committee, which you may attend. If you feel that your comments have not received a fair hearing you should make your views known to the ASTM Committee on Standards, at the address shown below.*

*This standard is copyrighted by ASTM International, 100 Barr Harbor Drive, PO Box C700, West Conshohocken, PA 19428-2959, United States. Individual reprints (single or multiple copies) of this standard may be obtained by contacting ASTM at the above address or at 610-832-9585 (phone), 610-832-9555 (fax), or service@astm.org (e-mail); or through the ASTM website (www.astm.org).*