



Standard Test Method for Fire Testing of Stacked Chairs¹

This standard is issued under the fixed designation E 1822; the number immediately following the designation indicates the year of original adoption or, in the case of revision, the year of last revision. A number in parentheses indicates the year of last reapproval. A superscript epsilon (ϵ) indicates an editorial change since the last revision or reapproval.

1. Scope

1.1 This is a fire-test-response standard.

1.2 This test method provides a means of determining the burning behavior of stacking chairs used in public occupancies by measuring specific fire-test responses when a stack of chairs is subjected to a specified flaming ignition source under well ventilated conditions.

1.3 This test method is limited to stacked chairs.

1.4 Test data are obtained describing the burning behavior following application of a specific ignition source, from ignition until all burning has ceased, a period of 1 h has elapsed, or flashover under test conditions appears inevitable.

1.5 This test method does not provide information on the fire performance of stacked chairs under fire conditions other than those conditions specified in this test method. In particular, this test method does not apply to smoldering ignition by cigarettes. See 5.11 for further information.

1.6 The rate of heat release of the burning test specimen is measured by an oxygen consumption method. See 5.11.4 for further information.

1.7 Other measurements are the production of light-obscuring smoke and the concentrations of certain toxic gas species in the combustion gases. See 5.11.5 for further information.

1.8 The burning behavior is documented visually by photographic or video recordings.

1.9 *This standard is used to measure and describe the response of materials, products, or assemblies to heat and flame under controlled conditions, but does not by itself incorporate all factors required for fire hazard or fire risk assessment of the materials, products or assemblies under actual fire conditions.*

1.10 Fire testing of products and materials is inherently hazardous, and adequate safeguards for personnel and property shall be employed in conducting these tests. This test method may involve hazardous materials, operations, and equipment.

1.11 Use the SI system of units in referee decisions; see Practice E 380. The units given in parentheses are for information only.

¹ This test method is under the jurisdiction of ASTM Committee E05 on Fire Standards and is the direct responsibility of Subcommittee E05.15 on Furnishings and Contents.

Current edition approved Sept. 10, 2002. Published November 2002. Originally published as E 1822 – 96. Last previous edition E 1822 – 02a.

1.12 *This standard does not purport to address all of the safety concerns, if any, associated with its use. It is the responsibility of the user of this standard to establish appropriate safety and health practices and determine the applicability of regulatory limitations prior to use.*

2. Referenced Documents

2.1 ASTM Standards:

D 123 Terminology Relating to Textiles²

E 84 Test Method for Surface Burning Characteristics of Building Materials³

E 176 Terminology of Fire Standards³

E 380 Practice for Use of the International System of Units (SI) (the Modernized Metric System)⁴

E 800 Guide for Measurement of Gases Present or Generated During Fires³

E 1354 Test Method for Heat and Visible Smoke Release Rates for Materials and Products Using an Oxygen Consumption Calorimeter³

E 1474 Test Method for Determining the Heat Release Rate of Upholstered Furniture and Mattress Components or Composites Using a Bench Scale Oxygen Consumption Calorimeter³

E 1537 Test Method for Fire Testing of Upholstered Furniture³

E 1590 Test Method for Fire Testing of Mattresses³

2.2 ISO Standards:

ISO 3261 Fire Tests—Vocabulary⁵

ISO 4880 Burning Behaviour of Textiles and Textile Products—Vocabulary⁵

ISO 9705 Fire Tests—Full Scale Room Test for Surface Products⁵

2.3 UL Standards:

UL 1056 Fire Test of Upholstered Furniture⁶

UL 1895 Fire Test of Mattresses⁶

2.4 CA Standards:

CA TB 129, Flammability Test Procedure for Mattresses for

² Annual Book of ASTM Standards, Vol 07.01.

³ Annual Book of ASTM Standards, Vol 04.07.

⁴ Annual Book of ASTM Standards, Vol 14.02.

⁵ Available from International Standardization Organization, P.O. Box 56, CH-1211, Geneva 20, Switzerland.

⁶ Available from Underwriters Laboratories, Inc., 333 Pfingsten Road, Northbrook, IL 60062.

Use in Public Buildings⁷
CA TB 133, Flammability Test Procedure for Seating Furniture for Use in Public Occupancies⁷

2.5 Other Document:

Nordtest Method NT Fire 032, Upholstered Furniture: Burning Behavior—Full Scale Test⁸

3. Terminology

3.1 *Definitions*—For definitions of terms used in this test method and associated with fire issues, refer to Terminology E 176 and ISO 3261. In case of conflict, the definitions in Terminology E 176 shall prevail. For definitions of terms used in this test method and associated with textile issues refer to Terminology D 123 and ISO 4880. In case of conflict, the definitions in Terminology D 123 shall prevail.

3.2 Definitions of Terms Specific to This Standard:

3.2.1 *stacking chair, n*—chair that is intended to be stacked when not in use.

3.2.2 *test specimen, n*—stack of five identical stacking chairs.

3.2.3 *upholstered, adj*—covered with material (as fabric or padding) to provide a soft surface.

3.2.4 *upholstered seating furniture, n*—a unit of interior furnishing that (1) contains any surface that is covered, in whole or in part, with a fabric or other upholstery cover material, (2) contains upholstery material, and (3) is intended or promoted for sitting upon.

3.2.5 *upholstery cover material, n*—the outermost layer of fabric or related material used to enclose the main support system, or upholstery materials, or both, used in the furniture unit.

3.2.6 *upholstery material, n*—the padding, stuffing, or filling material used in a furniture item, which may be either loose or attached, enclosed by an upholstery cover material, or located between the upholstery cover material and support system, if present.

3.2.6.1 *Discussion*—This includes, but is not limited to, material such as foams, cotton batting, polyester fiberfill, bonded cellulose, or down.

4. Summary of Test Method

4.1 This fire-test-response test method determines a number of fire-test-response characteristics associated with a stack of five stacking chairs, ignited with a propane gas burner. Measurements to be made include the rate of heat and smoke release, total amount of heat released, rates and concentrations of carbon oxides released, and rates and amounts of mass of test specimen lost. Other optional measurements are also described.

4.2 In Test Configurations A and B, the test specimen is placed on a weighing platform located in a test room. An exhaust hood, connected to a duct, is located at the doorway of the room.

4.3 In Test Configuration C, the test specimen is placed on a weighing platform located directly under a hood.

4.4 Heat, smoke, and combustion gas release instrumentation is placed in the duct.

4.5 Additional (optional) instrumentation placed in the test room is also described.

5. Significance and Use

5.1 This test method provides a means of measuring a variety of fire-test-response characteristics resulting from burning a stack of five stacking chairs. After ignition using a propane gas burner, the test specimen is permitted to burn freely under well-ventilated conditions. The most important fire-test-response characteristic measured in this test method is the rate of heat release, which quantifies the intensity of the fire generated.

5.2 The rate of heat release is measured by the principle of oxygen consumption. Annex A3 discusses the assumptions and limitations.

5.3 This test method also provides measures of other fire-test-response characteristics, including smoke obscuration (as the rate of smoke release, total smoke released or optical density of smoke), combustion gas release (as concentrations of combustion gases), and mass loss, that are important to making decisions on fire safety.

5.4 In the majority of fires, the most important gaseous components of smoke are the carbon oxides present in all fires. They are indicators of the toxicity of the atmosphere and of the completeness of combustion. Measurement of concentrations of carbon oxides are useful for two purposes: as part of fire hazard assessment calculations and to improve the accuracy of heat-release measurements. Other toxic combustion gases, which are specific to certain materials, are also indicators of the toxicity of the atmospheres, but are less crucial for determining combustion completeness and are optional measures; however fire hazard assessment often requires their measurement.

5.5 The type of ignition chosen (flaming source) is common in both accidental and intentional fires in public occupancies. This test method is thus applicable to stacked chairs in public occupancies. Such facilities include, but are not limited to, health-care facilities, old-age convalescent and board and care homes, college dormitories and residence halls, and hotels and motels.

5.6 One of the following three configurations is to be used in this test method:

5.6.1 *Test Configuration A*—A test room with the following dimensions: 3.66 by 2.44 by 2.44 m high (12 by 8 by 8 ft).

5.6.2 *Test Configuration B*—A test room with the following dimensions: 3.66 by 3.05 by 2.44 m high (12 by 10 by 8 ft).

5.6.3 *Test Configuration C*—An open calorimeter (or furniture calorimeter).

⁷ Available from California Bureau of Home Furnishings and Thermal Insulation, State of California, Department of Consumer Affairs, 3485 Orange Grove Ave., North Highlands, CA 95660-5595.

⁸ Available from Nordtest, P.O. Box 22, SF-00341, Helsingfors, Finland.

5.7 Rooms of other dimensions are acceptable where it has been shown that equivalent test results are obtained.

5.8 Measurements in the three test configurations listed in 5.6 have been shown to give similar results for heat release in the duct and mass loss up to a rate of heat release of 600 kW (1).⁹

5.9 Measurements of temperatures, gas concentrations, and smoke obscuration in the room are dependent on room size.

5.10 Studies on the flammability performance of furniture indicate that bench-scale fire tests are useful for preliminary evaluations of component materials for substitution purposes (see Appendix X2).

5.11 *Limitations:*

5.11.1 This test method is not applicable to ignition by cigarettes or by any other smoldering source.

5.11.2 The ignition source in this test method is a flaming source. Moreover, this particular ignition source has been shown to be able to provide a distinction among different kinds of stacked chairs. However, the fraction of actual flaming stacked chair fires occurring with ignitions more or less intense than that used here is not known.

5.11.3 It is not known whether the results of this test method will be equally valid when stacking chairs are burned under conditions different from those specified. In particular, it is unclear whether the use of a different ignition source, the same ignition source but having a different duration of flame exposure, or a different gas-flow rate will change the results.

5.11.4 The value of rate of heat release corresponding to the critical limit between propagating fires and nonpropagating fires is not known.

5.11.5 As yet, there is not a known direct correlation between smoke obscuration or smoke toxicity measurements in the exhaust duct and overall fire hazard.

6. Apparatus

6.1 *Room Layout and Instrumentation:*

6.1.1 *Test Room Layout (Test Configuration A)*—The test room shall have dimensions of 2.44 m ± 25 mm by 3.66 m ± 25 mm by 2.44 m ± 25 mm high (8 by 12 by 8 ft). The room shall have no openings other than a doorway opening 0.76 m ± 6.4 mm by 2.03 m ± 6.4 mm (30 by 80 in.), located as indicated in Fig. 1, and other small openings, as necessary to make test measurements. Construct the test room of wooden or metal studs and line it with fire-rated gypsum wallboard or calcium silicate wallboard. Position a hood, as described in Annex A1, outside the room doorway, such that it collects all of the combustion gases. There shall be no obstructions to the air supply to the test setup.

NOTE 1—Both Type X gypsum wallboard and calcium silicate wallboard with a nominal thickness of at least 13 mm (0.5 in.) have been found acceptable. If the thickness of the wallboard used is greater, it will not affect the results of this test method.

6.1.2 *Test Room Layout (Test Configuration B)*—The test room shall have dimensions of 3.05 m ± 25 mm by 3.66 m ± 25 mm by 2.44 m ± 25 mm high (10 by 12 by 8 ft). The room

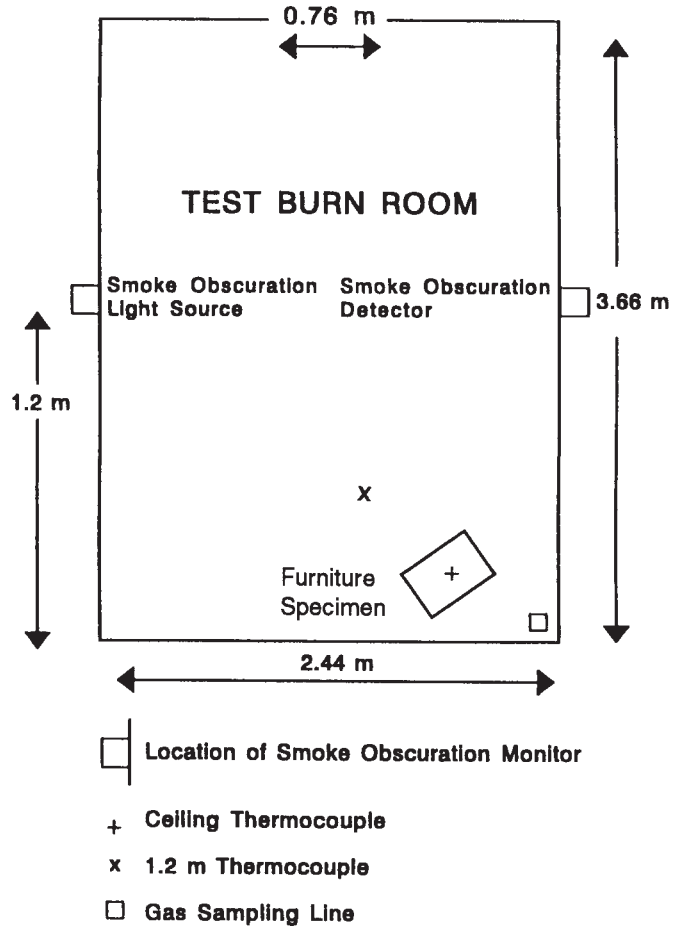

NOTE 1—See text for tolerances; room instrumentation is optional.

FIG. 1 Test Room Configuration for Test Configuration A

shall have no openings other than a doorway opening 0.97 m ± 6.4 mm by 2.06 m ± 6.4 mm (38 by 81 in.), located as indicated in Fig. 2, and other small openings, as necessary to make test measurements. Construct the test room of wooden or metal studs, and line it with fire-rated gypsum wallboard or calcium silicate wallboard. Position a hood, as described in Annex A1, outside the room doorway, such that it collects all of the combustion gases. There shall be no obstructions to the air supply to the test setup.

NOTE 2—Both Type X gypsum wallboard and calcium silicate wallboard with a nominal thickness of at least 13 mm (0.5 in.) have been found acceptable. If the thickness of the wallboard used is greater, it will not affect the results of this test method.

6.1.3 *Open Calorimeter Layout (Test Configuration C):*

6.1.3.1 The area surrounding the test specimen in an open calorimeter layout shall be sufficiently large that there are no heat radiation effects from the walls or any other nearby objects. The airflow to the test specimen shall be symmetrical from all sides.

6.1.3.2 If the heat release rate of the test specimen is below 600 kW, a load cell sited under a hood, and where the distance between the test specimen and any wall is 1 m (3.3 ft) or more, is acceptable.

6.1.3.3 The air supply to the calorimeter shall be sufficient so that it does not affect the burning process.

⁹ The boldface numbers in parentheses refer to the list of references at the end of this test method.

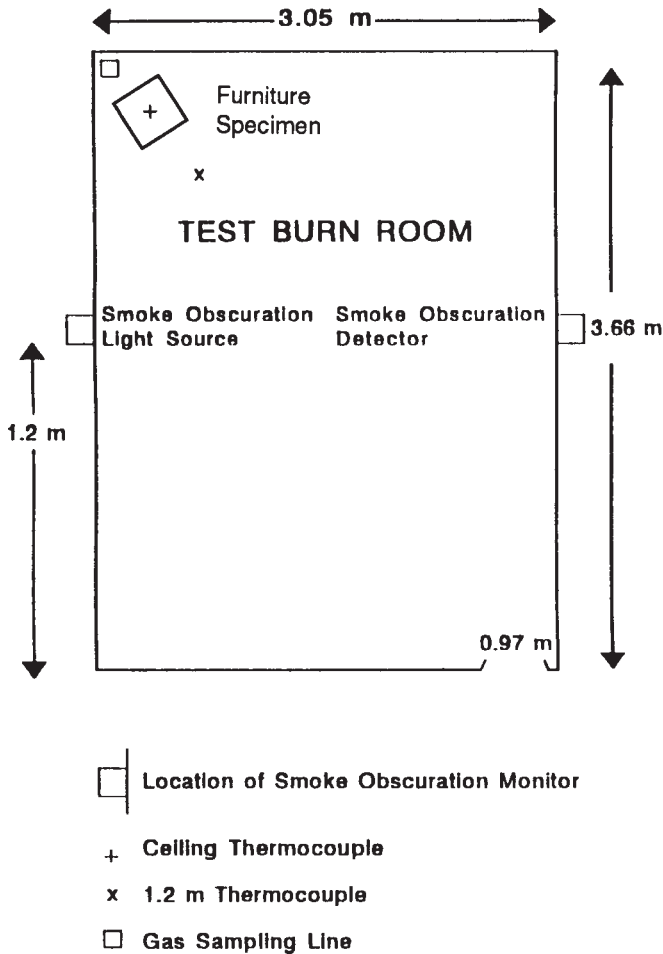

NOTE 1—See text for tolerances; room instrumentation is optional.
FIG. 2 Test Room Configuration for Test Configuration B

6.1.4 *General Discussion of Room Layout:*

6.1.4.1 Heat release measurements in the duct, made in Test Configurations A, B, and C have been shown to give similar results for heat release rates below 600 kW (see X1.4) (1).

6.1.5 *Other Test Room Furnishings*—The test room shall contain no furnishings except for the test specimen.

6.1.6 *Location of Test Specimen, for Test Configurations A or B*—Position the test specimen on a weighing platform in a corner. Ensure that the test specimen is at a distance of between 0.10 and 0.25 m (4 and 10 in.) from both walls (Fig. 1 and Fig. 2).

6.1.7 *Location of Test Specimen, for Test Configuration C*—Position the test specimen on a weighing platform underneath the hood.

6.2 *Ignition Source:*

6.2.1 Use as the ignition source a gas burner in the shape of a T, as shown in Fig. 3.

6.2.2 Construct the burner of stainless steel with wall thicknesses of 0.89 ± 0.05 mm (0.035 ± 0.002 in.). Make the head of the T 205 ± 10 mm (8 ± 0.4 in.) long and 13 ± 1 mm (0.5 ± 0.04 in.) outside diameter. Plug the ends of the T. As shown in Fig. 3(a) and Fig. 3(b), construct the burner with two sets of holes equally spaced and centered along the head of the burner and oriented 90° to one another. One set consists of 14

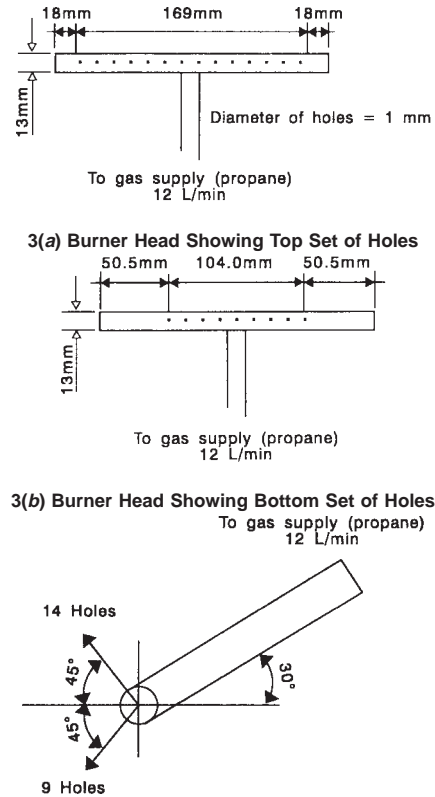

3(c) Side View of Burner Showing Orientation of the Head with the Handle

NOTE 1—See text for tolerances.
FIG. 3 View of T-Shaped Gas Burner

holes and the other set of nine holes, each hole spaced 13 ± 1 mm (0.5 ± 0.04 in.) from the next. Make the holes 1 ± 0.04 mm (0.039 ± 0.002 in.) in diameter.

NOTE 3—It is common for the burner holes to become clogged following a test. Inspect burner holes after each test and clean thoroughly if required. Take care not to enlarge the holes when cleaning them.

6.2.3 Construct the handle of the burner of stainless steel with the same diameter and thickness as the head. Weld it to the head in the orientation shown in Fig. 3(c). When the 14 holes in the head are oriented 45° above the horizontal and the nine holes are oriented 45° below the horizontal, the handle is approximately 30° above the horizontal. Construct the handle such that it is at least 450 mm (18 in.) long to facilitate its attachment to the support and the propane line.

NOTE 4—To align the burner to the test specimen properly, it is necessary to position the head as described below; therefore, the angle between the handle and the head is not critical.

6.2.4 Use propane gas with a known net heat of combustion of 46.5 ± 0.5 MJ/kg as a fuel for this ignition source. Meter the flow rate of propane at 12 ± 0.25 L/min, at a pressure of 101 ± 5 kPa (standard atmospheric pressure measured at the flow gage), and a temperature of $20 \pm 5^\circ\text{C}$ or at a flow equivalent to these values. Use flexible tubing fed into the handle of the burner to deliver the propane to the burner. Maintain the flow rate constant of propane while the flame is lit. Mount the burner on an adjustable pole, with a counterweight if necessary,

to allow the burner to be positioned in the proper location for ignition of the test specimen and then swung out of the way after the propane gas flame is turned off.

6.2.5 The approximate ratio of heat release rate output to gas flow rate is 1.485 kW min/L under standard conditions. Thus, the calculated rate of heat release from the burner at the temperature and pressure given above is 17.8 kW.

6.2.6 Location of Gas Burner:

6.2.6.1 Orient the burner with respect to the test specimen as shown in Fig. 3 (a, b, and c).

6.2.6.2 Ensure that the horizontal plane of the head of the burner (depicted in Fig. 3(c)) is level with the bottom horizontal surface of the lowest chair in the test specimen. This orientation shall be such that the 14 holes are directed at the test specimen at an angle of 45° above the horizontal, and the nine holes are directed under the lowest chair in the test specimen at an angle 45° below the horizontal. The handle will be set, nominally, at 30° above the horizontal.

6.2.6.3 Locate the burner during ignition in such a way that the burner is parallel with the front edge of the lowest chair in the test specimen, 25 ± 2 mm (1 ± 0.1 in.) from the vertical edge of the chair and 50 ± 2 mm (2 ± 0.1 in.) below the bottom horizontal edge of the lowest chair in the test specimen, as shown in Fig. 4.

6.3 Mass Loss Measurements:

6.3.1 Use a weighing platform to measure the mass of the burning test specimen continuously. Construct a weighing platform consisting of a horizontal thermal barrier, as described in 6.3.2, and placed on top of a mass measuring device.

6.3.2 Construct a thermal barrier large enough to prevent melting or falling material from the tested stacked chairs specimen from falling off the thermal barrier. The barrier shall consist of a galvanized steel pan with a gypsum board lining placed on the test specimen. The barrier shall be used to protect the load cell. The pan shall be constructed of nominally 1.6 mm (1/16 in.) thick steel, and have dimensions of no less than 1.0 by 1.0 m (39 by 39 in.), with a uniform raised lip of the same material, 100 ± 10 mm (approximately 4 in.) high, on each side, to catch falling material. The bottom of the pan shall be covered by a tight-fitting section of standard gypsum board (finish side up), of nominally 13 mm (0.5 in.) thickness. The

gypsum board shall be clean before the start of a test; the board shall be replaced for each test.

6.3.3 Measure the test specimen mass continuously with a device capable of an accuracy of no less than ±150 g up to at least 90 kg. Install it in such a way that neither the heat from the burning test specimen nor any eccentricity of the load will affect the accuracy. Do not make any range shifts during measurements. Install all parts of the mass measuring device below the top level of the thermal barrier.

6.3.4 The distance from the upper surface of the thermal barrier to floor level shall not exceed 0.3 m (12 in.). The area between the thermal barrier and the floor level shall be shielded by a skirt at the perimeter of the barrier to prevent lifting forces due to fire-induced air flow that influence the measurement.

6.4 Exhaust Collection System:

6.4.1 General:

6.4.1.1 Construct the exhaust collection system with the following minimal requirements: a blower, steel hood, duct, bidirectional probe, thermocouple(s), oxygen measurement system, smoke obscuration measurement system (white light photocell lamp/detector or laser), and combustion gas sampling and analysis system. Construct the exhaust collection system as shown in Fig. 5 and as explained in Annex A1.

6.4.1.2 Ensure that the system for collecting the smoke (that includes gaseous combustion products) has sufficient exhaust capacity and is designed in such a way that all of the combustion products leaving the burning test specimen are collected. Design the capacity of the evacuation system such that it will exhaust minimally all combustion gases leaving the test specimen (see A1.1.4).

6.4.1.3 Place probes for sampling of combustion gas and for measurement of flow rate in accordance with 6.5.

6.4.1.4 Make all measurements of smoke obscuration, gas concentrations, or flow rates at a position in the exhaust duct where the exhaust is mixed uniformly so there is a nearly uniform velocity across the duct section.

6.4.1.5 To ensure uniform mixing of the exhaust, provide a straight section of duct before the measuring system having a length equal to at least eight times the inside diameter of the

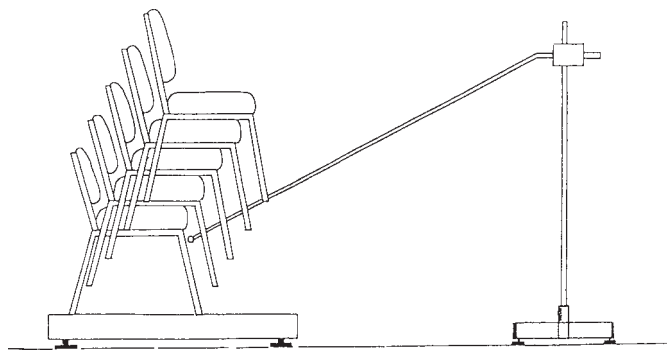

NOTE 1—This example of upholstered chairs has no gaps between the seats or backs. The burner is placed below the bottom of the seat cushion frame.

FIG. 4 (a) Positioning of the Ignition Source—T Burner

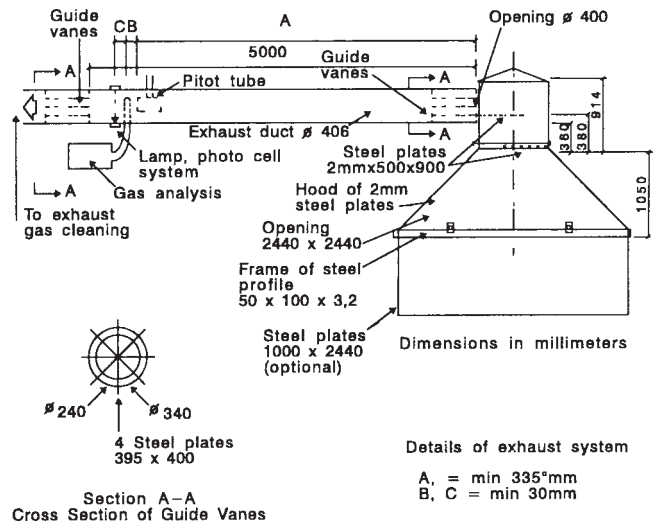

FIG. 5 Design of Hood and Exhaust System

duct. If a measuring system is positioned at a distance of less than eight diameters, demonstrate the achievement of equivalent results.

6.5 Instrumentation in Exhaust Duct:

6.5.1 The following specifications are minimum requirements for exhaust duct instrumentation. Additional information is given in Annex A2.

6.5.2 Flow Rate—Measure the flow rate in the exhaust duct by a bidirectional probe or an equivalent measuring system with an accuracy of at least $\pm 6\%$ (see Annex A2). The response time to a stepwise change of the duct flow rate shall not exceed 5 s to reach 90 % of the final value.

6.6 Combustion Gas Analysis:

6.6.1 Sampling Line—Construct the sampling line tubes of a material not influencing the concentration of the combustion gas species to be analyzed. The following sequence of the gas train has been shown to be acceptable: sampling probe, soot filter, cold trap, gas path pump, vent valve, plastic drying column and carbon dioxide removal columns (if used), flow controller, and oxygen analyzer (see Fig. 6 and Annex A2). Alternative designs of the sampling line must yield equivalent results. The gas train shall also include appropriate spanning and zeroing facilities.

6.6.2 Oxygen Measurement—Measure the oxygen concentration with an accuracy of ± 0.01 vol % oxygen, or better, in order to have adequate measurements of rate of heat release. Take the combustion gas sample from the end of the sampling line. Calculate the time delay, including the time constant of the instrument, from the test room; it is a function of the exhaust duct flow rate. This time delay shall not exceed 60 s (see Annex A2).

6.6.3 Carbon Monoxide and Carbon Dioxide Measurement—Measure the combustion gas species with an instrument having an accuracy of at least ± 0.1 vol % for carbon dioxide and ± 0.02 vol % for carbon monoxide. A suitable output range is from 0 to 1 vol % for carbon monoxide and from 0 to 6 vol % for carbon dioxide. Take the combustion gas sample from the end of the sampling line. Calculate the time delay, including the time constant of the instrument, from

the test room; it is a function of the exhaust duct flow rate. It shall be a maximum of 60 s (see Annex A2).

6.6.4 For optional measurement of other combustion gases see A2.3.3.

6.7 Smoke Obscuration Measurement:

6.7.1 Install an optical system for measurement of the light obscuration across the centerline of the exhaust duct. Determine the optical density of the smoke by measuring the light transmitted with a photometer system consisting of a white light source and a photocell/detector or a laser system for measurement of light obscuration across the centerline of the exhaust duct.

6.7.2 One photometer system found suitable consists of a lamp, lenses, an aperture, and a photocell (see Fig. 7 and Annex A2). Construct the system so soot deposits on the optics during a test. Do not reduce the light transmission by more than 5 %.

6.7.3 Alternatively, instrumentation constructed using a 0.5 to 2.0 mW helium-neon laser instead of a white-light system is also acceptable (see Fig. 8, Fig. A1.1, and Annex A2). It has been shown that white-light and laser systems will provide similar results (see Refs (2-5)).

7. Test Specimen

7.1 The test specimen is a stack of five identical stacking chairs, or prototype thereof.

7.2 If prototype stacking chairs are used, the prototypes shall, in all respects, reflect the construction of the actual stacking chairs.

7.3 Fire tests of stacking chairs have shown that the fire performance of stacked chairs is significantly affected by chair design and configuration, the gap between adjacent seat surfaces, and the vertical gap between adjacent seat backs. Therefore, it is critical to ensure that the five stacking chairs are carefully stacked in accordance with the design features of the chairs to be tested.

8. Calibration

8.1 Calibrate all instruments carefully with standard sources after initial installation. Among the instruments to be calibrated

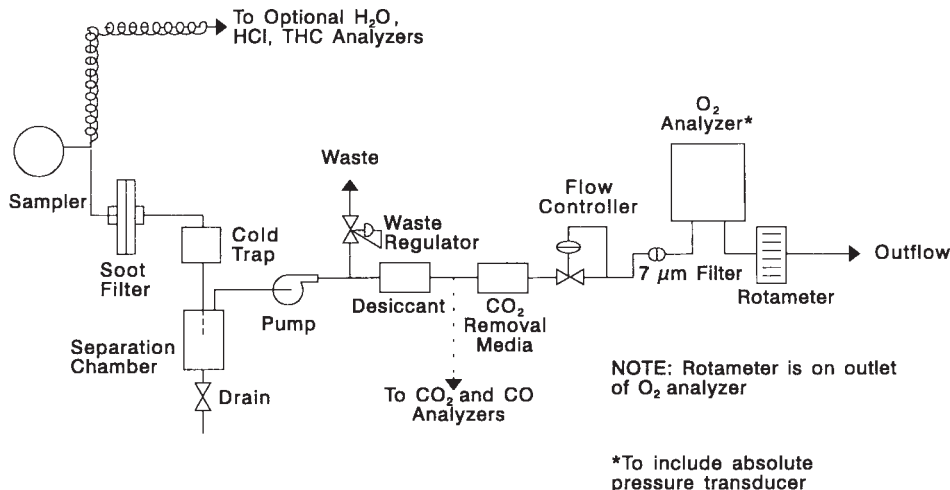

FIG. 6 Schematic of Gas Train

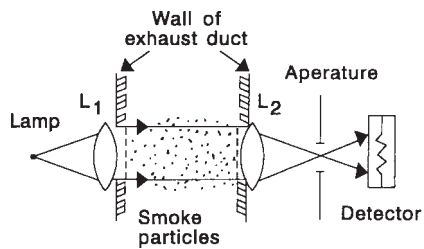

FIG. 7 Optical System Using a White Light

are load cells or weighing platforms, smoke meters, flow or velocity transducers, and gas analyzers. Perform recalibration tests on the entire system, for example using standard output burners.

8.2 Heat Release:

8.2.1 Perform the calibration of the heat release instrumentation in the exhaust duct by burning propane or methane gas and comparing the heat release rates calculated from the metered gas input and those calculated from the measured oxygen consumption. The value of net heat of combustion for methane is 50.0 MJ/kg and for propane is 46.5 MJ/kg. Position the burner in the same location where the test specimen is to be placed during the test. Measure the gas flow rate at a pressure of 101 ± 5 kPa (standard atmospheric pressure, measured at the flow gage) and a temperature of $20 \pm 5^\circ\text{C}$.

8.2.2 A suitable calibration burner is a sand diffusion burner with a 0.3 by 0.3 m (12 by 12 in.) top surface and a 0.15 m (6 in.) depth. Construct such a gas burner with a 25 mm (1 in.) thick plenum. Alternatively, use a minimum 100 mm (4 in.) layer of Ottawa sand to provide the horizontal surface through which the gas is supplied. This burner is shown in Fig. 9. The gas supply to the burner shall be propane (the same quality used for the ignition burner) or methane. The gas for the burner flame shall not be premixed with air. Meter the flow rate of gas and keep it constant throughout the calibration test.

8.2.3 Another suitable calibration burner is a pipe with an inner diameter of 100 ± 1.5 mm (4 in.) supplied with gas from beneath (see ISO 9705). The gas for the burner flame shall not be premixed with air.

8.2.4 Obtain a minimum of two calibration points. Obtain a lower heat release rate value of 40 kW and then a higher heat release rate value of 160 kW. Approximate propane flow rates for any required heat release rate value are estimated using the following constant: 1.485 kW min/L, determined at a pressure of 101 ± 5 kPa (standard atmospheric pressure; measured at the flow gage) and a temperature of $20 \pm 5^\circ\text{C}$.

8.2.5 Take measurements at least once every 6 s and start 1 min prior to ignition of the burner. Determine the average rate of heat release over a period of at least 1 min by the oxygen consumption method and calculating the heat release rate from the gas mass flow rate and the net heat of combustion. The difference between the two values shall not exceed 5 %. This comparison shall be made only after steady-state conditions have been reached.

8.2.6 Perform a calibration test in accordance with 8.5 prior to each continuous test series. Perform a full basic calibration on a new system or when modifications are introduced.

8.2.7 When calibrating a new system, or when modifications are introduced, check the response time of the measuring system by the following test sequence:

| Time, min | Burner Output, kW |
|-----------|-------------------|
| 0-5 | 0 |
| 5-10 | 40 |
| 10-15 | 160 |
| 15-20 | 0 |

The response of the system to a stepwise change of the heat output from the burner shall be a maximum of 12 s to 90 % of final value.

8.2.8 Perform the calibration given in 8.2.7 with the initial duct air flow rate equal to that to be used in the test procedure.

8.2.9 The change in measured rate of heat release, comparing time average values over 1 min, shall not be more than 10 % of the actual heat output from the burner.

8.2.10 The use of a higher rate of heat release for calibration, for example 500 kW, will generally lead to higher accuracy in the test results.

8.3 Mass Loss—Perform calibration of the mass-measuring device by loading the weighing platform with known masses corresponding to the measuring range of interest, to ensure that the requirements of accuracy in 6.3.3 are fulfilled. Carry out this calibration daily, prior to testing.

8.4 Smoke Obscuration—Calibrate the smoke meter initially to read correctly for two neutral density filters of significantly different values, and also at 100 % transmission. The use of neutral density filters at 0.5 and 1.0 values of optical density has been shown to be satisfactory for this calibration. Once this calibration is set, only the zero value of extinction coefficient (100 % transmission) must be verified each day, prior to testing. Investigate any excessive departure from the zero line at the end of a test, and correct it.

8.5 Gas Analysis— Calibrate the gas analyzers daily, prior to testing (see Guide E 800).

9. Conditioning

9.1 Prior to testing, condition the chairs for at least 48 h in an atmosphere at a temperature of $21 \pm 4^\circ\text{C}$ ($70 \pm 7^\circ\text{F}$) and a relative humidity of less than 60 %. Test the specimen as soon as possible after removal from such conditions if the test room conditions differ from the above. Report the time between removal from the conditioning room and the start of testing.

10. Procedure

10.1 Initial Conditions:

10.1.1 The ambient temperature shall be above 15°C (60°F) and the relative humidity shall be below 75 %.

10.1.2 The horizontal air flow, measured at both the surface and at a horizontal distance of 0.5 m (20 in.) from the edge of the weighing platform, shall not exceed 0.5 m/s^{-1} .

10.1.3 Position the test specimen centrally on the weighing platform.

10.1.4 Have available means for extinguishing a fully developed fire.

10.2 Test Procedure:

10.2.1 Perform the measurements needed to obtain the descriptive information needed for the test report.

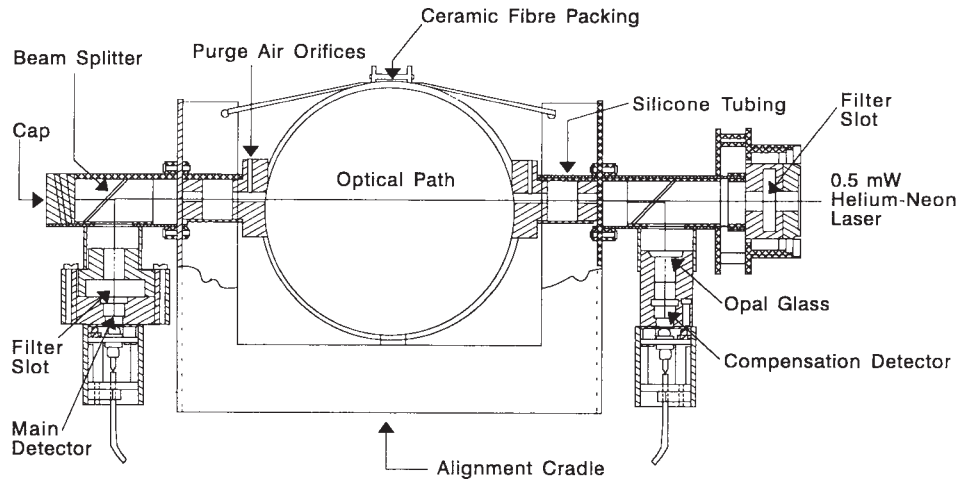
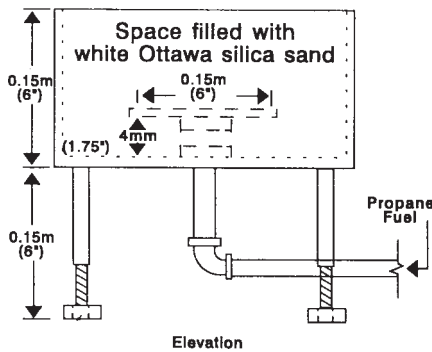
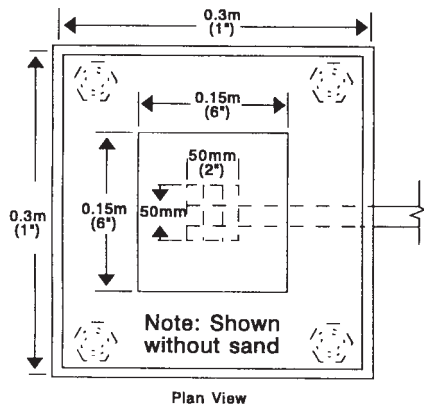

FIG. 8 Laser Extinction Beam



NOTE 1—See text for tolerances.
FIG. 9 Calibration Gas Burner

10.2.2 Weigh the test specimen immediately upon removal from conditioning room and immediately before the start of test.

10.2.3 Place the T-shaped propane gas burner in front of the test specimen, as specified in 6.2.6. Confirm that burner holes have been cleaned (see Note 3).

10.2.4 Begin all recording and measuring devices 2 min before starting the ignition burner.

10.2.5 Light the ignition burner.

10.2.6 Expose the test specimen to the gas burner flames for 80 s, at a flow rate of 12 L/min, determined at a pressure of 101 ± 5 kPa (standard atmospheric pressure, measured at the flow gage) and a temperature of $20 \pm 5^\circ\text{C}$.

10.2.7 Extinguish the gas flame and remove the burner after the specified burning period (80 s).

10.2.8 Perform a photographic or a video recording before and during each test. An indication of elapsed time, giving time to the nearest 1 s, shall appear in all photographic records.

10.2.9 During the test, record the following events and the time when they occur, with respect to the time of ignition of the burner:

10.2.9.1 Ignition of the first igniting chair,

10.2.9.2 Location of the flame front at various appropriate times,

10.2.9.3 Melting and dripping,

10.2.9.4 Occurrence of pool fire under the test specimen,

10.2.9.5 General description of the burning behavior, and

10.2.9.6 Any other event of special interest.

10.2.10 Terminate the test after the first of the following:

10.2.10.1 All signs of combustion have ceased,

10.2.10.2 One hour of testing has elapsed, or

10.2.10.3 Flashover appears inevitable.

10.2.11 Note, from visual inspection of the specimen after the test, the approximate percentage of each surface that was burned or charred, and the approximate depth of fire damage.

11. Calculation

11.1 Considerations for heat release measurements are presented in Annex A3. Calculate the heat release data, using the equations presented in A4.1. The testing laboratory shall choose one of the equations given in A4.1 for calculating heat release, based on the gas analyzers installed.

11.2 Calculate the smoke release data using the equations presented in A4.2.

11.3 Calculate the gas yield data using the equations presented in A4.3.

12. Report

- 12.1 Report the following descriptive information:
- 12.1.1 Name and address of the testing laboratory,
 - 12.1.2 Date and identification number of the report,
 - 12.1.3 Name and address of the test requester,
 - 12.1.4 Test configuration used: A, B, or C,
 - 12.1.5 Name of product manufacturer or supplier, if known,
 - 12.1.6 Name or other identification marks and description of the chairs,
 - 12.1.7 Linear dimensions (height, width, depth) of each individual chair and of the test specimen,
 - 12.1.8 Total mass, thickness of the main components and mass of combustible portion of each test specimen,
 - 12.1.8.1 Weight change of the test specimen between removal from conditioning room and start of test,
 - 12.1.9 Density, or mass per unit surface area of the main components in each chair, if known,
 - 12.1.10 Conditioning of the chairs,
 - 12.1.11 Date of the test,
 - 12.1.12 Test number and any special remarks, and
 - 12.1.13 Time between the removal from conditioning room and start of testing.
- 12.2 Include the following test results in the test report (see also appendixes):
- 12.2.1 Table of numerical results containing the following:
 - 12.2.1.1 Peak rate of heat release (in kW), and the time at which it occurred,
 - 12.2.1.2 Total heat released (in MJ),
 - 12.2.1.3 Total heat released at 10 min (in MJ),
 - 12.2.1.4 Peak rate of smoke release (in m²/s⁻¹), and the time at which it occurred,
 - 12.2.1.5 Total smoke released (in m²),
 - 12.2.1.6 Total smoke released at 10 min (in m²),
 - 12.2.1.7 Total mass loss (in kg),
 - 12.2.1.8 Total mass loss at 10 min (in kg),
 - 12.2.1.9 Total percentage of mass loss (in %),
 - 12.2.1.10 Peak concentration of carbon monoxide (in ppm),
 - 12.2.1.11 Peak temperatures (in °C),
 - 12.2.1.12 Equation used to calculate rate of heat release,
 - 12.2.1.13 Peak optical density of smoke (optional),
 - 12.2.1.14 Average optical density of smoke, over the 10-min period including the peak (optional),
 - 12.2.1.15 Total percentage of combustible mass loss (in %) (optional),

- 12.2.1.16 Average yield of carbon monoxide (in g CO/g fuel) (optional),
 - 12.2.1.17 Average yield of carbon dioxide (in g CO₂/g fuel) (optional),
 - 12.2.1.18 Carbon monoxide/carbon dioxide molar yield ratio (optional), and
 - 12.2.1.19 Average yield of any other measured combustion gas (in g combustion gas/g fuel) (optional).
- 12.2.2 *Graphical Results (Optional):*
- 12.2.2.1 Plot of rate of heat release versus time,
 - 12.2.2.2 Plot of rate of smoke release versus time,
 - 12.2.2.3 Plot of optical density versus time,
 - 12.2.2.4 Plot of mass loss versus time,
 - 12.2.2.5 Plot of concentration of carbon monoxide versus time,
 - 12.2.2.6 Plot of concentration of carbon dioxide versus time,
 - 12.2.2.7 Plots of concentration of any other measured combustion gas versus time,
 - 12.2.2.8 Plot of mass flow rate in the exhaust duct versus time,
 - 12.2.2.9 Plot of duct temperature versus time, and
 - 12.2.2.10 Report smoke obscuration, carbon monoxide and temperature measurements in the room in the same fashion, if they have been made.

12.2.3 *Descriptive Results:*

- 12.2.3.1 Photographs or videotape of the fire development, and
- 12.2.3.2 All available information requested in 10.2.9 through 10.2.11.

13. Precision and Bias

13.1 *Precision:*

13.1.1 *Initial Repeatability*—The results of a repeatability study from one laboratory, involving six different sets of stacked chairs are shown in Table 1 and Table X4.1 to Table X4.6. Three tests were conducted for each type of stacking chair in Test Configuration C (furniture calorimeter). The percentage relative standard deviation or coefficient of variation (100 times the ratio of the standard deviation and the average) for various properties (initial mass, peak heat release rate, total heat release, peak smoke release rate, total smoke release, mass loss, and time to peak heat release rate) were

TABLE 1 Stacking Chair Test Results—Chair Set 6 (See X4.6)

NOTE 1—A and B represent the constant and coefficient of the equation:

$$r (\text{repeatability}) = A + B * \text{property}$$

NOTE 2—RSD % and Avg represent the averages of, respectively, the percentage relative standard deviations and average values for every type of stack tested.

| | Initial Mass, kg | Peak Heat Release Rate, kW | Total Heat Released, MJ | Peak Smoke Release Rate, m ² /s | Total Smoke Released, m ² | Mass Loss, kg | Time to Peak Heat Release Rate, min |
|------|---------------------|----------------------------------|-------------------------------|--|--|------------------|---|
| A | 0.14 | -79 | 41 | 0.48 | 163 | 0.30 | -0.59 |
| B | 0.011 | 0.25 | -0.065 | -0.0058 | 0.022 | 0.075 | 0.26 |
| Avg | 37.7 | 863 | 265 | 5.1 | 1235 | 9.6 | 12.1 |
| RSD% | 1 | 14 | 14 | 17 | 18 | 16 | 20 |

averaged for all tests (see Table 1). The constant (A) and coefficient (B) correspond to the terms in the equation:

$$\text{Repeatability } (r) = A + B * \text{property} \quad (1)$$

The results shows that the average of the relative standard deviations is less than 25 % for all properties analyzed, although some individual relative standard deviations also exceed 20 %.

13.1.2 *Interlaboratory Repeatability and Reproducibility*—Table 2 and Table 3 show the precision obtained in an interlaboratory round-robin evaluation conducted with 4 laboratories, using three sets of stacking chairs (labeled S1 to S3), stacked in groups of 5 for test, supplied by different manufacturers, and all commercially available. Two of the laboratories conducted the tests using the "ASTM room", and the other two used the "California room". The data obtained from all four laboratories were analyzed. In Table 2, outliers and "obviously incorrect data" were excluded, using standard statistical considerations and information from the test lab reports submitted. It should be noted that some tests in some laboratories were incorrectly terminated before the mandated end point, after some guidelines were exceeded. The complete set of major data was also analyzed, without eliminating any data point, with the statistical analysis included as Table 3. It is possible to conduct an analysis of the data that excludes all incorrect data but does not exclude outliers, but that was not done. A Research Report has been submitted to ASTM which includes all the information required for a full understanding of results. The user is encouraged to consult this research report entitled: "Test Methods E 1537 & E 1822 Interlaboratory Precision Study, Prepared by: ASTM E05.15" (2001). The abbreviations used are as follows: peak rate of heat release (Pk RHR), total heat released (THR), mass loss at 10 min (Mass Loss @ 10), peak rate of smoke release (Pk RSR), total smoke released (RSR), standard deviation for repeatability and reproducibility (STD repeat and STD Repro), relative standard deviation for

repeatability and reproducibility (RSD repeat and RSD Repro), repeatability (r) and Reproducibility (Repro).

13.2 Bias:

13.2.1 No information is presented on the bias of the procedure in this test method because correct values of fire-test-response characteristics of stacked chairs can only be defined in terms of a test method. Within this limitation, this test method has no known bias and is acceptable as a reference test method.

13.2.2 For solid test specimens of unknown chemical composition, as used in building materials, furnishings, and common occupant fuel load, it has been documented that the use of the oxygen consumption standard value of 13.1 MJ/kg oxygen for the net amount of heat released per unit of oxygen consumed for complete consumption, results in an expected error band of ± 5 % compared to the true value. For homogeneous materials with only a single pyrolysis mechanism, this uncertainty is reduced by determining the net heat of combustion from oxygen-bomb measurements and the stoichiometric oxygen/fuel mass ratio from ultimate elemental analysis. For testing relevant to this test method, this is not practical, since the test specimens are finished products, some of which are nonhomogeneous and capable of exhibiting degradation reactions. Therefore, for unknown test specimens, a ± 5 % accuracy limit is observed. For reference materials, however, it is likely that careful determination of the net heat released per unit of oxygen consumed will make this source of uncertainty substantially less.

14. Keywords

14.1 calorimetry; carbon dioxide; carbon monoxide; chair; fire; fire testing; fire-test response; furniture; heat release; ignition; oxygen consumption; smoke obscuration; stacked chair; stacking chair; toxic combustion gases

TABLE 2 Intralaboratory and Interlaboratory Precision Results of Round Robin Evaluation Excluding Outliers and Incorrect Data

| Stack | Property/Units | Average | STD repeat | STD Repro | r | R | RSD repeat | RSD Repro |
|-------|---------------------------|---------|------------|-----------|--------|--------|------------|-----------|
| S1 | Pk RHR/kW | 14.7 | 4.3 | 4.3 | 12.0 | 12.0 | 29.2 | 29.2 |
| S2 | Pk RHR/kW | 23.6 | 8.7 | 8.7 | 24.5 | 24.5 | 37.0 | 37.0 |
| S3 | Pk RHR/kW | 503.4 | 156.4 | 156.4 | 437.8 | 437.8 | 31.1 | 31.1 |
| S1 | THR @ 10/MJ | 1.7 | 1.6 | 1.6 | 4.4 | 4.4 | 94.4 | 94.4 |
| S2 | THR @ 10/MJ | 3.8 | 2.1 | 2.1 | 5.8 | 5.8 | 53.8 | 53.8 |
| S3 | THR @ 10/MJ | 70.8 | 39.8 | 39.8 | 111.6 | 111.6 | 56.3 | 56.3 |
| S1 | time to Pk RHR/s | 110.9 | 29.9 | 64.7 | 83.8 | 181.1 | 27.0 | 58.3 |
| S2 | time to Pk RHR/s | 436.0 | 745.2 | 745.2 | 2086.5 | 2086.5 | 170.9 | 170.9 |
| S3 | time to Pk RHR/s | 595.5 | 131.2 | 131.2 | 367.3 | 367.3 | 22.0 | 22.0 |
| S1 | Mass Loss @ 10/kg | 0.2 | 0.3 | 0.3 | 0.8 | 0.8 | 167.0 | 167.0 |
| S2 | Mass Loss @ 10/kg | 0.3 | 0.1 | 0.2 | 0.4 | 0.6 | 49.9 | 75.6 |
| S3 | Mass Loss @ 10/kg | 7.2 | 2.4 | 2.4 | 6.6 | 6.6 | 32.6 | 32.6 |
| S1 | Pk RSR, m ² /s | 0.6 | 1.1 | 1.1 | 3.1 | 2.1 | 174.3 | 174.3 |
| S2 | Pk RSR, m ² /s | 1.0 | 0.7 | 0.9 | 1.9 | 2.4 | 67.7 | 85.1 |
| S3 | Pk RSR, m ² /s | 1.9 | 0.7 | 0.7 | 2.0 | 2.0 | 37.0 | 37.0 |
| S1 | TSR, m ² | 91.6 | 45.4 | 78.3 | 127.1 | 219.3 | 49.6 | 85.5 |
| S2 | TSR, m ² | 78.2 | 61.1 | 64.5 | 171.1 | 180.6 | 78.1 | 82.4 |
| S3 | TSR, m ² | 697.1 | 210.1 | 350.1 | 588.2 | 980.3 | 30.1 | 50.2 |
| S1 | time to Pk RSR/s | 119.9 | 45.1 | 45.1 | 126.3 | 126.3 | 137.6 | 137.6 |
| S2 | time to Pk RSR/s | 82.9 | 6.0 | 6.0 | 16.9 | 16.9 | 7.3 | 7.3 |
| S3 | time to Pk RSR/s | 793.2 | 955.8 | 955.8 | 2676.3 | 2676.3 | 120.5 | 120.5 |

TABLE 3 Intralaboratory and Interlaboratory Precision Results of Round Robin Evaluation of Without Excluding Outliers or Incorrect Data

| Stack | # labs | Average | STD repeat | STD Repro | r | R | RSD repeat | RSD Repro |
|---|--------|---------|------------|-----------|--------|---------|------------|-----------|
| Peak RHR/kW | | | | | | | | |
| S1 | 4 | 63.2 | 86.02 | 119.3 | 240.9 | 334.0 | 136.1 | 188.8 |
| S2 | 4 | 38.2 | 50.8 | 53.2 | 142.2 | 149.0 | 133.0 | 139.3 |
| S3 | 4 | 505.7 | 78.9 | 163.6 | 220.9 | 458.1 | 15.6 | 32.4 |
| Total Heat Released @ 10 min/MJ | | | | | | | | |
| S1 | 4 | 1.74 | 0.79 | 0.79 | 2.2 | 2.2 | 45.4 | 45.4 |
| S2 | 4 | 3.73 | 1.11 | 2.08 | 3.1 | 5.8 | 29.8 | 55.8 |
| S3 | 4 | 71.5 | 20.8 | 46.7 | 58.2 | 130.8 | 29.1 | 65.3 |
| time to peak RHR/s | | | | | | | | |
| S1 | 4 | 349 | 430 | 556 | 1204.0 | 1556.8 | 123.2 | 159.3 |
| S2 | 4 | 631 | 820 | 979 | 2296.0 | 2741.2 | 130.0 | 155.2 |
| S3 | 4 | 592 | 72.8 | 173.7 | 203.8 | 486.4 | 12.3 | 29.3 |
| Mass Loss @ 10 min/kg | | | | | | | | |
| S1 | 4 | 0.19 | 0.15 | 0.24 | 0.4 | 0.7 | 78.9 | 126.3 |
| S2 | 4 | 1.47 | 4.11 | 4.29 | 11.5 | 12.0 | 279.6 | 291.8 |
| S3 | 4 | 7.15 | 1.16 | 4.73 | 3.2 | 13.2 | 16.2 | 66.2 |
| Peak RSR/m ² /s | | | | | | | | |
| S1 | 4 | 0.71 | 0.55 | 0.78 | 1.5 | 2.2 | 77.5 | 109.9 |
| S2 | 4 | 1.02 | 0.68 | 1.27 | 1.9 | 3.6 | 66.7 | 124.5 |
| S3 | 4 | 4.32 | 3.78 | 5.97 | 10.6 | 16.7 | 87.5 | 138.2 |
| Total Smoke Released @ 10 min/m ² | | | | | | | | |
| S1 | 4 | 68.3 | 74.3 | 92.3 | 208.0 | 258.4 | 108.8 | 135.1 |
| S2 | 4 | 259 | 52.8 | 433 | 147.8 | 1212.4 | 20.4 | 167.2 |
| S3 | 4 | 929 | 964 | 10010 | 2699.2 | 28028.0 | 103.8 | 1077.5 |
| Total Smoke Released entire test/m ² | | | | | | | | |
| S1 | 4 | 177.5 | 299.6 | 301.5 | 838.9 | 844.2 | 168.8 | 169.9 |
| S2 | 4 | 1539 | 1165 | 3073 | 3262.0 | 8604.4 | 75.7 | 199.7 |
| S3 | 4 | 816 | 484 | 721 | 1355.2 | 2018.8 | 59.3 | 88.4 |
| time to peak RSR/s | | | | | | | | |
| S1 | 4 | 218 | 201 | 264 | 562.8 | 739.2 | 92.2 | 121.1 |
| S2 | 4 | 442 | 804 | 969 | 2251.2 | 2713.2 | 181.9 | 219.2 |
| S3 | 4 | 715 | 509 | 717 | 1425.2 | 2007.6 | 71.2 | 100.3 |

ANNEXES

(Mandatory Information)

A1. DESIGN OF EXHAUST SYSTEM

A1.1 Design of Hood and Exhaust Duct:

A1.1.1 Collect the combustion gases from the burning test specimen by means of a hood. A system is described as follows which has been tested in practice and proven to fulfill the specifications given in this test method.

A1.1.2 The hood is located just outside the room doorway. The following bottom dimensions of the hood have been found satisfactory: 2.4 by 2.4 m (8 by 8 ft), with the height of the hood itself of 1.0 m (3 ft–4 in.), (see Fig. 5). The hood feeds into a plenum having a 0.9 by 0.9-m (3 by 3-ft) cross sectional area. The plenum has a height of 0.9 m (3 ft). The maximum acceptable plenum height is 1.8 m (6 ft), depending on building constraints. A system with different dimensions is acceptable, provided that equivalence has been demonstrated.

A1.1.3 In the plenum chamber, it has been found that the incorporation of two plates approximately 0.5 by 0.9 m in size, see Fig. 5, is a satisfactory way of increasing mixing of the

combustion gases. Alternative gas mixing methods are acceptable if equivalence has been demonstrated. Design and manufacture the hood so that no leakage exists.

A1.1.4 If a laser beam is used, a suitable means of mounting the beam together with the combustion gas sampling probes is shown in Fig. A1.1.

A1.1.5 Connect an exhaust duct to the plenum chamber. The inner diameter of the exhaust duct is 0.4 to 1.0 m (16 to 40 in.). To facilitate flow measurements, guide vanes, if needed, are located at both ends of the exhaust duct, Fig. 8. Alternatively, the rectilinear part of the exhaust duct must have a length such that a fully developed flow profile is established at the point of measurement. Connect the exhaust duct to an evacuation system.

A1.1.6 Design the capacity of the evacuation system to exhaust minimally all combustion gases leaving the test specimen. This requires an exhaust capacity of at least 2.7

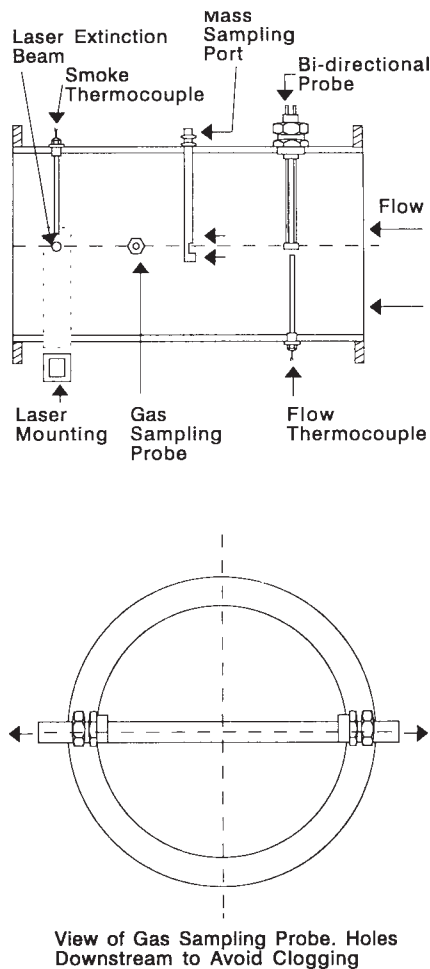

FIG. A1.1 Satisfactory Method for Mounting the Laser Beam and Other Instrumentation in Exhaust Duct

kg/s⁻¹ (approximately 8000 m³/h⁻¹ at standard atmospheric conditions) corresponding to a driving under pressure of approximately 2 kPa at the end of the duct. Provide a means of controlling the exhaust flow from approximately 0.5 kg/s⁻¹ up to maximum flow, as stated previously, during the test process. Ensure that the measurement system has a sensitivity sufficient for measuring low rates of heat release. Mixing vanes in the duct are an adequate means of solving the problem if concentration gradients are found to exist.

A1.1.7 An alternative exhaust system design is acceptable if it is shown to produce equivalent results. Equivalency is demonstrated by meeting the calibration requirements given in Section 8. Exhaust system designs based on natural convection are unacceptable.

A2. INSTRUMENTATION IN EXHAUST DUCT

A2.1 Flow Measurement:

A2.1.1 One technique for measuring the flow is a bidirectional probe located at the center line of the duct. The probe shown in Fig. A2.1 consists of a stainless steel cylinder 44 mm (1.75 in.) long and with an inner diameter of 22 mm (0.875 in.). The cylinder has a solid diaphragm in the center, dividing it into two chambers. The pressure difference between the two chambers is measured by a differential pressure transducer.

A2.1.2 Use a differential pressure transducer with an accuracy of at least ±0.25 Pa (0.001 in. of water) and of the capacitance type. A suitable range of measurement is from 0 to 150 Pa.

A2.1.3 Place one thermocouple within 152 mm (6 in.) of the bidirectional probe. Use an Inconel sheathed thermocouple, Type K Chromel-Alumel. The wire gage shall be in the range from 24 to 30 AWG (0.51 to 0.36 mm diameter). Place the thermocouple wire, within 13 mm (0.5 in.) of the bead, along expected isotherms to minimize conduction errors. Use an

insulation between the Chromel and Alumel wires that is stable to at least 1100°C (2000°F). Ensure that the thermocouple does not disturb the flow pattern around the bidirectional probe.

A2.2 Sampling Line:

A2.2.1 Place the sampling probe in a position where the exhaust duct flow is uniformly mixed. Construct the probe with a cylindrical cross section to minimize disturbance of the air flow in the duct. Collect the combustion gas samples across the entire diameter of the exhaust duct (see Fig. A2.2).

A2.2.2 Remove the particulates contained in the combustion gases with inert filters, to the degree required by the gas analysis equipment. Conduct the filtering procedure in more than one step. Cool the combustion gas mixture to a maximum of 10°C. The combustion gas samples taken to each analyzer shall be dried completely.

A2.2.3 Transport the combustion gases by a pump. Use a pump that does not allow the gases to contact oil, grease, or similar products, all of which can contaminate the gas mixture.

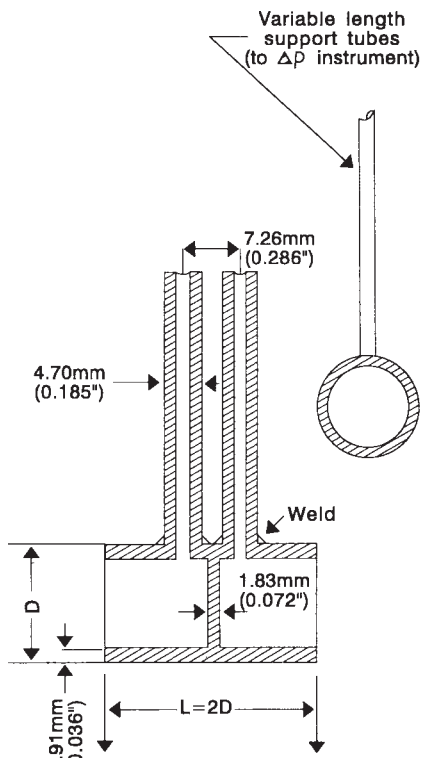

FIG. A2.1 Bidirectional Probe

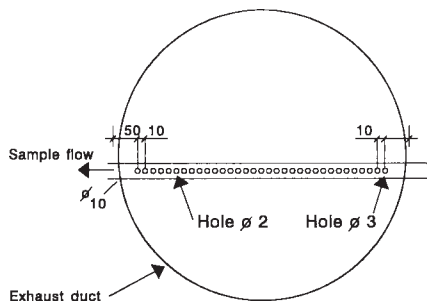

FIG. A2.2 Sample Probe of the Bar Type

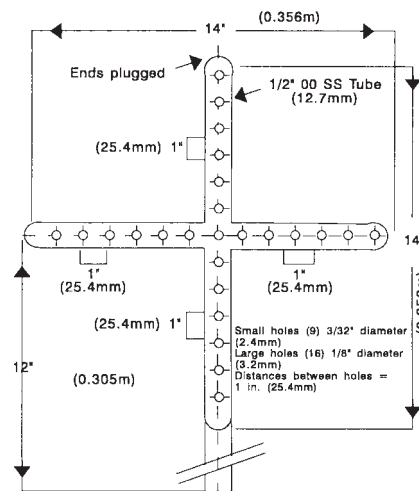
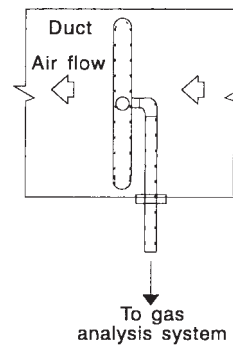

FIG. A2.3 Sampling Probe of the Cross-Shaped Type

A diaphragm pump (coated with polytetrafluoroethylene) is suitable. Alternative pumps shown to have the same effect are acceptable, but they have often been shown to need frequent replacement.

A2.2.4 Suitable sampling probes are shown in Fig. A2.2 and Fig. A2.3. These sampling probes are of the bar and cross type. Ring-type sampling probes are also acceptable, although they do not collect gas samples across the full diameter of the duct. Turn the intake of the sampling probe downstream to avoid soot clogging the probe.

A2.2.5 A suitable pump has a capacity of 10 to 50 L/min⁻¹ at 10 kPa (minimum), as each gas analysis instrument consumes approximately 1 L/min⁻¹. A pressure differential of at least 10 kPa, as generated by the pump, reduces the risk of smoke clogging the filters.

A2.2.6 Install a soot filter, capable of removing all particles >25 μm in size.

A2.2.7 The most satisfactory means of cooling and drying the combustion gases is to use a refrigerated column. The

recommended approach is to use a refrigerated column and separation chamber with a drain plug from which the collected water is removed from time to time (see Fig. 6). Alternate devices show to give equivalent results are also acceptable.

A2.2.8 If carbon dioxide is to be removed, use carbon dioxide removal media, as indicated in Fig. 6.

A2.3 Combustion Gas Analysis:

A2.3.1 *Oxygen Concentration*—Use an oxygen analyzer, meeting the specifications given in 6.6.2.1, preferably of the paramagnetic type and including an absolute pressure transducer to compensate for gas pressure variations.¹⁰ Locate a rotameter on the outlet of the oxygen analyzer (see Fig. 6).

A2.3.2 *Carbon Monoxide and Dioxide Concentration*—Analyzers found suitable are nondispersive infrared analyzers. See Guide E 800 for further guidance.

A2.3.3 *Other Combustion Gases*—Use Guide E 800 for details of suitable analyzers when the optional measurements of the concentrations of other combustion gases, such as water, total hydrocarbon, nitrogen oxide, hydrogen cyanide, or hydrogen chloride, are to be made.

¹⁰ A Siemens Oxymat 2 or a Servomex 540 A has been found suitable for this purpose.

A2.3.4 *Time Shift*— Combustion gas concentration measurements require the use of appropriate time shifts to account for gas analyzer response and for combustion gas transit time within the sampling system. For each gas analyzer used, determine the system delay time for the analyzer to reach a 90 % response to a step change in the gas concentration.

A2.4 *Smoke Obscuration:*

A2.4.1 *White Light System:*

A2.4.1.1 One suitable light measuring system based on white light has the following components: a lamp, plano convex lenses, an aperture, a photocell, and an appropriate power supply. Mount the lenses, lamp, and photocell inside two housings, located on the exhaust duct, diametrically opposite each other. It has been found that, in some cases, a system consisting solely of a white light and a photocell, along the exhaust duct, across from each other and at an angle to the vertical, is satisfactory, in some cases.

A2.4.1.2 Use a lamp of the incandescent filament type, which operates at a color temperature of 2900 ± 100 K. Supply the lamp with stabilized direct current, stable within ± 0.2 % (including temperature, short-term, and long-term stability). Center the resultant light beam on the photocell. See A2.4.1.6 for an example of a system that has been found suitable.

A2.4.1.3 Select the lens system such that the lens L_2 , in accordance with Fig. 7, has a diameter, d , chosen with regard to the focal length, f , of L_2 so that $d/f \geq 0.04$. See A2.4.1.6 for an example of a system that has been found suitable.

A2.4.1.4 Place the aperture in the focus of lens L_2 in accordance with Fig. 7. See A2.4.1.6 for an example of a system that has been found suitable.

A2.4.1.5 Use a detector with a spectrally distributed response in accordance with the CIE photopic curve and linear within 5 % over an output range of at least 3.5 decades. Check this linearity over the entire range of the instrument periodically with calibrated optical filters. See A2.4.1.6 for an example of a system that has been found suitable.

A2.4.1.6 The following system is an example of a light measuring system that has been found to be satisfactory:

A2.4.1.7 *Lenses*—Plano convex, 40-mm diameter, 50-mm focal length.

A2.4.1.8 *Lamp*—Osram Halo Stars, 64 410, 6 V, 10 W, or equivalent.

A2.4.1.9 *Photocell*—United Detector Technology, PIN 10 AP, or equivalent.

A2.4.1.10 *Voltage Supply*—Gresham Lion Ltd, Model G \times 012, or equivalent.

A2.4.1.11 Design a system that is purged easily against soot deposits. The use of holes in the periphery of the two housings is a means of achieving this objective.

A2.4.2 *Laser System*—An acceptable alternate system for measurements of smoke obscuration uses a helium-neon laser, silicon photodiodes as main beam, and reference detectors and appropriate electronics to derive an extinction coefficient and to set a zero reading. The system is designed for split yoke mounting in two pieces, which are rigidly coupled together, but resiliently attached to the exhaust duct by refractory gasketing. Project a 0.5 to 2.0 mW helium-neon laser beam horizontally across the exhaust duct (see Fig. 8).¹¹

¹¹ Suppliers of such systems include Atlas Electric Devices Co., 4114 N. Ravenswood Ave., Chicago, IL 60613 and Fire Testing Technology Ltd, P.O. Box 116, East Grinstead, West Sussex, RH19 2YE, UK.

A3. CONSIDERATIONS FOR HEAT RELEASE MEASUREMENTS

A3.1 *Measurement of Rate of Heat Release by Oxygen Consumption:*

A3.1.1 *Introduction*— In 1917, Thornton (6) showed that for a large number of organic fuels, a more or less constant net amount of heat is released per unit of oxygen consumed for complete combustion. Huggett (7) obtained an average value for this constant of 13.1 MJ/kg of O₂. This value may be used for practical applications and is accurate, with very few exceptions, to within ± 5 %.

A3.1.2 Thornton's rule indicates that it is sufficient to measure the oxygen consumed in a combustion system in order to determine the net heat released. This is particularly useful for full-scale fire test applications. For example, for compartment fires, the oxygen consumption technique is much more accurate and easier to implement than methods based on measuring all of the terms in a heat balance of the compartment.

A3.1.3 Perhaps the first application of the oxygen consumption principle in fire research was by Parker (8) using Test Method E 84 (tunnel test). Later, Sensenig applied it to an intermediate scale room test (9). During the late seventies and early eighties, the O₂ consumption technique was refined at the

National Institute for Standards and Technology (NIST, formerly National Bureau of Standards). A paper by Parker (10) provides equations for calculating the rate of heat release by oxygen consumption for various applications. The technique is now used extensively in many laboratories all over the world, both in bench-scale (11) and full-scale (12,13) fire test applications.

A3.1.4 The objective of this section is to provide a comprehensive set of equations and guidelines for determining the rate of heat release in full-scale fire tests based on the O₂ consumption principle. The approach followed here is somewhat different from Parker (10) as the emphasis is on full-scale fire test applications and the use of volumetric flow rates is avoided. Volumetric flow rates require specification of temperature and pressure. Various investigators have used different combinations of reference pressure and temperature. This leads to confusion, that is greatly minimized if mass flow rates are used.

A3.1.5 The basic requirement is that all combustion products be collected in a hood and removed through an exhaust duct. At a distance downstream of the hood sufficient for adequate mixing, both the flow rate and the composition of the

combustion gases are measured. It is assumed here that it is not possible to measure the air flow rate into the system, as this is generally the case for full-scale fire tests. The differences in treatment and equations to be used are due mainly to the extent to which combustion gas analysis is made. Oxygen shall be measured in all cases. However, heat release rate measurements will be more accurate by measuring carbon dioxide (CO₂) and carbon monoxide (CO) additionally.

A3.1.6 It must be emphasized that the analysis is approximate. The following list describes the main simplifying assumptions made:

A3.1.6.1 The amount of energy released by complete combustion per unit of oxygen consumed is taken as: $E = 13.1$ MJ/kg of O₂.

A3.1.6.2 All combustion gases are considered to behave as ideal gases. In other words one mole of any gas is assumed to occupy a constant volume at the same pressure and temperature.

A3.1.6.3 Incoming air consists of O₂, CO₂, H₂O, and N₂. Concentrations of all inert gases that do not take part in the combustion reactions are included with that of the nitrogen.

A3.1.6.4 The O₂, CO₂, and CO are measured on a dry basis. In other words water vapor is removed from the sample before combustion gas analysis measurements are made.

A3.1.7 In the analysis to follow, initial emphasis will be placed on the flow rate measurement. Equations for calculating flow rate are applicable, unless otherwise indicated, regardless of the configuration of the combustion gas analysis system. Distinction is made, in subsequent sections, between various combustion gas analyzer combinations.

A3.2 Flow Measurements:

A3.2.1 Two techniques are most often used to measure mass flow rate in the exhaust duct of full-scale fire tests.

A3.2.2 The first technique measures mass flow rate by way of the pressure drop across, and temperature at, an orifice plate (see Eq A4.1). If the test is conducted within a narrow range of conditions, the orifice-plate coefficient, C , is approximately constant. Determine the value of the orifice-plate coefficient using a gas burner calibration or an alternative method that provides equivalent results. However, if flow rates are varied during a test or if temperature changes are considerable, the effect on C of the Reynolds number and pressure at the downstream side of the orifice plate must be taken into account. Information on such corrections and on various design options (for example the location of the pressure taps) are found in Ref (14).

A3.2.3 The second technique is to measure velocity at one point in the duct, usually along the centerline. The flow rate is then calculated using a predetermined shape of the velocity profile in the duct. The latter is obtained by measuring velocity at a sufficient number of representative points over the diameter or cross section of the duct prior to any fire tests. Detailed procedures for obtaining this profile are described in (15). Usually, conditions in full-scale fire tests are such that the flow in the duct is turbulent, resulting in a shape factor k_c (= ratio of the average velocity to the velocity along the centerline) close to one.

A3.2.4 Due to considerable soot production in many fires, pitot static tubes cannot be used because of the potential for clogging of the holes. In order to deal with this problem, a more robust bidirectional probe was designed by McCaffrey and Heskestad (16). This involves measuring the differential pressure across the probe and the centerline velocity (see Eq A4.2), and is valid in the range of Reynolds numbers, Re :

$$40 < Re < 3800 \quad (\text{A3.1})$$

In many full-scale fire test applications, duct diameter and flow rate are such that the Reynolds number is:

$$Re > 3800 \quad (\text{A3.2})$$

In this case, $f(Re)$ is taken as a constant (1.08) that simplifies the calculations greatly. In the system described, the Reynolds number is usually greater than 3800 so that $f(Re) = 1.08$. Further details of this and of all other calculations discussed in this annex are presented in a paper by Janssens (17). For additional details, see also ISO 9705.

A3.3 Rate of Heat Release Measurement if Only Oxygen Concentration Measurements are Used for Calculation:

A3.3.1 In this case, all water vapor and CO₂ are eliminated by the use of appropriate filtering media. This leads to the assumption that the sample combustion gas consists of O₂ and N₂ only. This is approximately true provided CO production is negligible. Since the composition of the incoming air is unlikely to change during a test, and since the temperatures in building fires are usually not high enough to generate noticeable amounts of nitrogen oxides by nitrogen fixation, the mole fraction of O₂ in the air as measured by the analyzer prior to a test is written on the basis of O₂ and N₂ exclusively. The mole fraction of O₂ in the exhaust combustion gases, as measured by the oxygen analyzer, is written in a similar manner. As nitrogen is conserved and does not participate in the combustion reactions, the equations are derived on the basis of its conservation.

A3.3.2 In this case the rate of heat released (in kilowatts) is calculated as a function of the heat released per unit of oxygen consumed (E , 13.1 MJ/kg of O₂), the ratio of the molecular weight of oxygen (M_1 , 32.0 kg/kmol) and the molecular weight of the incoming air (M_2 , generally taken as 28.97 kg/kmol), and the mass flow rate of the incoming air (in kg/s). The flow rate measured is that of the smoke within the exhaust duct and not that of the incoming air. In order to find a relation between the two, it is necessary to define the oxygen depletion factor. The oxygen depletion factor is the fraction of the incoming air which is fully depleted of its oxygen (see Eq A4.4). It has been demonstrated (see the appendix in Test Method E 1354), that the rate of heat release is a function of E , M_1 , M_2 , and the oxygen depletion factor, plus the expansion factor.

A3.3.2.1 The expansion factor value must be assigned. Use 1.105, the value for methane for testing. Other values are 1.084 (for propane), 1.0 (for carbon in dry air), and 1.21 (for hydrogen). Use 1.084 for calibrations made with propane gas.

A3.3.3 The resulting equation, Eq A4.5, is expected to be accurate to within $\pm 5\%$ provided combustion is complete. In other words all the carbon is converted to CO₂. Errors will be greater if CO or soot production is considerable or if a

significant amount of the combustion products is other than CO₂ and H₂O. It is unlikely that these errors will be of concern for a single stack of chairs.

A3.4 Rate of Heat Release Measurement if Oxygen and Carbon Dioxide Concentration Measurements are Used for Calculation—This case is similar to that covered in the former section. It is now assumed that only water vapor is trapped before the sample reaches the combustion gas analyzers. Again, the equations, are derived on the basis of conservation of nitrogen. The mole fraction of CO₂ in the incoming air is taken to be 330 ppm. A new equation is now required for the oxygen depletion factor: Eq A4.7. Again the equation for rate of heat release (see Eq A4.6) is accurate to within ±5 % provided combustion is complete. In other words, all of the carbon is converted to CO₂.

A3.5 Rate of Heat Release Measurement if Oxygen, Carbon Dioxide, and Carbon Monoxide Concentration Measurements are Used for Calculation—This case reverts to that covered in A3.4 if CO production is negligible. Taking CO into account, however, changes the equations. It means that a new oxygen depletion factor is required, Eq A4.7, as well as a new rate of heat release equation altogether, Eq A4.8.

A3.6 Calculation of Heat Released by Igniting Fuel:

A3.6.1 Part of the oxygen depletion in the exhaust duct is due to the combustion of the ignition source fuel. This part must be subtracted from the total oxygen depletion in order to determine the net rate of heat release of the test specimen.

A3.6.2 For a gas burner, Janssens (17) has derived an equation to take into account this value. This equation is acceptable, but its use is accompanied by some difficulties, such as the delay in the response of the instrumentation in the exhaust duct, the problem of filling of an enclosure, and other experimental difficulties. A simpler alternative way of measuring the net heat released by the test specimen is to subtract the heat release measured in the calibration from the heat obtained in the equations. This heat yields a baseline rate of heat release curve.

A3.7 Conclusions:

A3.7.1 Depending on the configuration of combustion gas analyzers and the type of flow rate measurement, one of the following procedures shall be used to calculate the rate of heat release:

A3.7.2 Case 1—Only O₂ concentration measurements are used:

A3.7.2.1 Calculate the mass flow rate of the exhaust combustion gases,

A3.7.2.2 Calculate the oxygen depletion factor, and

A3.7.2.3 Calculate the rate of heat release.

A3.7.3 Case 2—Both O₂ and CO₂ concentration measurements are used:

A3.7.3.1 Calculate the mass flow rate of the exhaust combustion gases as in A3.7.2,

A3.7.3.2 Calculate the new oxygen depletion factor, and

A3.7.3.3 Calculate the new rate of heat release.

A3.7.4 Case 3—O₂, CO₂, and CO concentration measurements are used:

A3.7.4.1 Calculate the mass flow rate of the exhaust combustion gases as in A3.7.2,

A3.7.4.2 Calculate the new oxygen depletion factor, and

A3.7.4.3 Calculate the new rate of heat release.

A3.7.5 If a CO₂ analyzer is used, this eliminates the need for removal of CO₂ from the combustion gas sample. This is mainly of practical importance since the scrubbing agent used to remove CO₂ usually requires careful handling and is rather expensive. If significant amounts of CO are produced (for example at or beyond flashover in ventilation-controlled room fires), the accuracy of the rate of heat release measurement is improved if CO is measured.

A3.7.6 The presence of a water vapor analyzer simplifies the analysis and improves accuracy even more. Unfortunately, the implementation of a water vapor analyzer is not straightforward because sampling lines, filters, etc. must be heated to prevent condensation. The use of a water vapor analyzer, thus, precludes the need to estimate the expansion factor. However, for this test method, the use of water analyzers is not recommended.

A4. MEASUREMENT EQUATIONS

A4.1 Rate of Heat Release (Symbols are Explained in A4.4):

A4.1.1 Flow Rate:

A4.1.1.1 Pressure Drop Measurement (see Eq A4.1):

$$\dot{m}_e = C * \sqrt{\left[\frac{\Delta p}{T_e}\right]} \quad (\text{A4.1})$$

A4.1.1.2 Velocity Measurement (see Eq A4.2):

$$\dot{m}_e = 26.54 * \frac{A * k_c}{f(Re)} * \sqrt{\left[\frac{\Delta p}{T_e}\right]} \quad (\text{A4.2})$$

If Eq A4.2 is used, determine k_c whenever the bidirectional probe or the duct are replaced. Do this by correlating the velocity measured by the bidirectional probe with a reference method, such as a pitot-static tube.

A4.1.1.3 The function of the Reynolds number $f(Re)$ has been described, by McCaffrey and Heskestad (8), as responding to Eq A4.3:

$$f(Re) = 1.533 - 1.366 \times 10^{-3} Re + 1.688 \times 10^{-6} Re^2 - 9.705 \times 10^{-11} Re^3 + 2.555 \times 10^{-13} Re^4 - 2.484 \times 10^{-17} Re^5 \quad (\text{A4.3})$$

A4.1.1.4 If $Re > 3800$, then $f(Re) = 1.08$.

A4.1.2 Case 1—Only O₂ concentration measurements are used. Calculate the rate of heat release in accordance with Eq A4.4:

$$\dot{Q}(t) = E \times 1.10 \times C \sqrt{\left[\frac{\Delta p}{T_e}\right]} \times \left[\frac{(X_{O_2}^o - X_{O_2})}{1.105 - 1.5 \times X_{O_2}^o}\right] \times (1 - X_{H_2O}^o) \quad (\text{A4.4})$$

Set the value of E for the test specimen equal to 13.1×10^3 kJ/kg unless a more exact value is known for the test material.

A4.1.3 *Case 2*—Only O₂ and CO₂ concentration measurements are used. Calculate the mass flow rate in accordance with Eq A4.1 or Eq A4.2 and the oxygen depletion factor in accordance with Eq A4.5:

$$\phi = \frac{X_{O_2}^o \times [1 - X_{CO_2}] - X_{O_2} \times [1 - X_{CO_2}^o]}{X_{O_2}^o \times [1 - X_{O_2} - X_{CO_2}]} \quad (A4.5)$$

and the rate of heat release in accordance with Eq A4.6:

$$\dot{Q}(t) = E \times \frac{\phi}{1 - \phi(\alpha - 1)} \times \dot{m}_e \times \frac{M_{O_2}}{M_a} \times (1 - X_{H_2O}^o - X_{CO_2}^o) \times X_{O_2}^o \quad (A4.6)$$

A4.1.4 *Case 3*—O₂ and CO₂ and CO concentration measurements are used. Calculate the mass flow rate in accordance with Eq A4.1 or Eq A4.2 and the oxygen depletion factor in Eq A4.7:

$$\phi = \frac{X_{O_2}^o \times [1 - X_{CO_2} - X_{CO}] - X_{O_2} \times [1 - X_{CO_2}^o]}{X_{O_2}^o \times [1 - X_{O_2} - X_{CO_2} - X_{CO}]} \quad (A4.7)$$

Finally, calculate the rate of heat release in accordance with Eq A4.8:

$$\dot{Q}(t) = \left[E \times \phi - (E_{CO} - E) \times \frac{1 - \phi}{2} \times \frac{X_{CO}}{X_{O_2}} \right] \times \frac{\dot{m}_e}{1 + \phi \times (\alpha - 1)} \times \frac{M_{O_2}}{M_a} \times (1 - X_{H_2O}^o) \times X_{O_2}^o \quad (A4.8)$$

A4.2 *Smoke Measurement Equations:*

A4.2.1 *Optical Density (OD)* (See Eq A4.9):

$$OD = \log [I_o/I] \quad (A4.9)$$

A4.2.2 *Extinction Coefficient (k)* (See Eq A4.10):

$$k = (1/L_p) * \ln (I_o/I) \quad (A4.10)$$

A4.2.3 The volumetric flow rate is calculated as the product of the mass flow rate and the density of air, at the corresponding temperature. Thus, both the volumetric flow and the density of air must undergo temperature corrections. The volumetric duct flow rate (\dot{V}) is adjusted because it is measured in the exhaust duct, but required at the temperature near the photo-detector, as shown in Eq A4.11:

$$\dot{V}_s = \dot{V}_e * \left(\frac{T_s}{T_e} \right) \quad (A4.11)$$

A4.2.4 The density of air is adjusted between the literature value, measured at 273.15 K, and the value at the temperature in the exhaust duct, as shown in Eq A4.12:

$$\rho = \rho_o * \frac{273.15}{T_e} \quad (A4.12)$$

A4.2.5 Then, the final equation for the volumetric flow rate is Eq A4.13:

$$\dot{V}_s = \frac{\dot{m}_e}{\rho_o} * \frac{T_e}{273.15} \quad (A4.13)$$

A4.2.6 Rate of smoke release (RSR) is defined by Eq A4.14:

$$RSR = [\dot{V}_s * k] \quad (A4.14)$$

A4.2.7 Total smoke released (TSR) is defined by Eq A4.15:

$$TSR = \int RSR dt \quad (A4.15)$$

A4.3 *Gas Yield Measurement Calculations:*

A4.3.1 Calculate the gas yields (f) using Eq A4.16:

$$f_x = \frac{\int \text{mass flow rate of gas}_x dt}{\text{mass loss of array of test specimens}} \quad (A4.16)$$

A4.3.2 The numerator in this equation is calculated by adding the product of the fraction of combustion gas by the total mass flow rate, measured at each scan, multiplying it by the total time period involved, and dividing by the number of scans, as shown in Eq A4.17:

$$f_x = \frac{(\sum_i ([x]_i * \dot{m}_{e(i)} * \Delta t_i)) * 0.001 * \frac{M_x}{M_a}}{\text{mass loss of array of test specimens}} \quad (A4.17)$$

A4.3.3 In this equation, $[x]$, the concentration of gas x , is expressed in part per million, \dot{m}_e , the mass flow rate, calculated by Eq A4.1 or Eq A4.2, is expressed in kilograms per second, M_x is the molecular weight of gas species x , M_a is the molecular weight of exhaust air (29 kg/kmol), Δt is the scan period and mass loss of the test specimen is the mass lost over the period over which the gas yield is calculated, and is expressed in grams, with 0.001 a conversion factor, to account for the unit changes.

A4.3.4 Report gas concentrations on a dry gas basis, unless water concentrations are being measured.

A4.4 *Symbols:*

| | | |
|-----------------|---|---|
| A | = | Cross-sectional area of duct (in m ²). |
| C | = | Orifice plate coefficient (in kg ^{1/2} m ^{1/2} K ^{1/2}). |
| E | = | Net heat released for complete combustion per unit of oxygen consumed (13 100 kJ/kg O ₂). |
| E_{CO} | = | Net heat released for complete combustion per unit of oxygen consumed for CO (17 600 kJ/kg O ₂). |
| $f(Re)$ | = | Reynolds number correction (nondimensional). |
| f_x | = | Yield of gas x (in g/g). |
| I | = | Light intensity for a parallel light beam having traversed a certain length of smoky environment and reaching photodetector (nondimensional). |
| I_o | = | Light intensity for a beam of parallel light rays, measured in a smoke-free environment, with a detector having the same spectral sensitivity as the human eye and reaching the photodetector (nondimensional). |
| k | = | Extinction coefficient (in 1/m). |
| k_c | = | Velocity profile shape factor (nondimensional). |
| L_p | = | Light path length of beam through smoky environment (in m). |
| \dot{m}_e | = | Mass flow rate in exhaust duct (in kg/s). |
| $\dot{m}_e = C$ | = | $(\Delta p/T_e)^{1/2}$ —Mass flow rate, by measurement of pressure drop, in kg/s, according to Eq A4.1. |
| \dot{m}_e | = | $(26.54 \times A \times k_c / (f(Re))) \times (\alpha/T_e)^{1/2}$ —Mass flow rate, by measurement of velocity drop, in kg/s, according to Eq A4.2. |

| | | | |
|--------------|--|------------------|---|
| M_a | = Molecular weight of incoming and exhaust air (29 kg/kmol). | \dot{V}_s | = Volumetric flow rate at location of smoke meter (value adjusted for smoke measurement calculations) (in m ³ /s). |
| M_{CO} | = Molecular weight of carbon monoxide (28 kg/kmol). | [x] | = Concentration of gas x (in ppm). |
| M_{CO_2} | = Molecular weight of carbon dioxide (44 kg/kmol). | X_{CO} | = Measured mole fraction of CO in exhaust flow (nondimensional). |
| M_{H_2O} | = Molecular weight of water (18 kg/kmol). | X_{CO_2} | = Measured mole fraction of CO ₂ in exhaust flow (nondimensional). |
| M_{N_2} | = Molecular weight of nitrogen (28 kg/kmol). | $X_{H_2O}^\circ$ | = Measured mole fraction of H ₂ O in incoming air (nondimensional). |
| M_{O_2} | = Molecular weight of oxygen (32 kg/kmol). | X_{O_2} | = Measured mole fraction of O ₂ in exhaust flow (nondimensional). |
| OD | = Optical density (nondimensional). | $X_{O_2}^\circ$ | = Measured mole fraction of O ₂ in incoming air (nondimensional). |
| ΔP | = Pressure drop across the orifice plate or bidirectional probe (in Pa). | α | = Combustion expansion factor (nondimensional; normally a value of 1.105). |
| $\dot{Q}(t)$ | = Heat release rate, as a function of time (in kW). | ρ | = Density of air at the temperature in exhaust duct (in kg/m ³). |
| RSR | = Rate of smoke release (in m ² /s). | ρ_o | = Density of air at 273.15 K (1.293 (kg/m ³)). |
| T_e | = Combustion gas temperature at the orifice plate (in K). | ϕ | = Oxygen depletion factor (nondimensional). |
| T_s | = Combustion gas temperature (near photodetector) (in K). | | |
| TSR | = Total smoke released (in m ²). | | |
| \dot{V}_e | = Volumetric flow rate in exhaust duct (at measuring location of mass flow rate) (in m ³ /s). | | |

APPENDIXES

(Nonmandatory Information)

X1. COMMENTARY

X1.1 Introduction—This commentary is provided to give some insight into the development of the test method and to describe a rationale for various features used. It is not recommended that this test method be used for regulatory purposes until more experience has been gained.

X1.2 Measurements:

X1.2.1 Rate of Heat Release:

X1.2.1.1 The rate of heat release is one of the most important variables, and may be even the single most important variable, in determining the hazard from a fire (18-22). In particular, the rate of heat release is a measure of the intensity of the fire. The rate of heat release and the amount of heat released will determine the extent to which other materials, products, or assemblies in the fire compartment will be ignited and spread the fire further. Thus, an item that releases heat very rapidly (that is, has a high rate of heat release) is more likely to ignite a nearby article than one that has a low rate of heat release. The mass loss rate is usually a direct function of the heat release rate.

X1.2.1.2 It is important to point out that the heat released by a product made up of more than one material can often not be predicted from the individual heats released by the individual components. Some recent literature describes heat release by materials (23,24) and the entire issue of heat release rate (25).

X1.2.1.3 The rate of heat release can be determined by measuring the oxygen concentration in a fire atmosphere (26-28). Oxygen concentration measurement devices, of the paramagnetic type, are now sufficiently precise to measure the

small differences in oxygen concentration needed for determining the rate of heat release.

X1.2.1.4 Heat release, smoke release, and combustion gas release measurements in the duct, and mass loss measurements, made in rooms of a height of 2.44 ± 25 mm (8 ft), with one horizontal dimension of between 2.41 m and 3.69 m and the other horizontal dimension such that the total floor area of the test room lies between 8.7 and 11.4 m² are likely to be equivalent. Similarly, those results, when measured in an open calorimeter, will also be equivalent.

X1.2.2 Smoke Obscuration—The visibility in a fire atmosphere will adversely affect the ability of victims to escape and the ability of fire fighters to fight the fire.

X1.2.2.1 It has been shown that the smoke release measured with a laser beam and with a white light system are equivalent, unless the scanning time is very long (>5 s). This has been determined both in small-scale instruments (2,3) and in full-scale cable tray testing facilities (4,5).

X1.2.2.2 The Beer-Lambert equation that relates concentration of particles to light beam attenuation is defined for individual wavelengths. Theoretically, thus, a monochromatic light beam, as from a laser, will yield more accurate results than a polychromatic light beam, as from white light.

X1.2.3 Smoke Toxicity—The victims of a fire are often overcome by the toxicity of the atmosphere. This is determined by the concentration of smoke (see Terminology E 176) and by the toxicity of its individual components. The overall amount of smoke generated can be measured by means of the mass loss rate, which is equivalent to the rate of smoke generation. In the

majority of fires, the single most important individual toxicant in a fire atmosphere is carbon monoxide, which is present in all fires together with carbon dioxide and water (29,30). Some other combustion gases, such as acrolein, hydrogen cyanide, and hydrogen chloride, are also frequently present and thus may also contribute to the toxicity of the fire atmosphere.

X1.3 *Stacked Chairs:*

X1.3.1 Several studies have shown that a fire involving a stack of chairs can be significantly more severe than a fire involving a single chair of the same type (31-34). In many public buildings, in facilities such as auditoriums, ballrooms, or large meeting rooms, it is common to have hundreds of units of moveable furniture. In such facilities, which are often used for a multitude of purposes, stacking chairs are often present in a variety of configurations. When in use, the floor surface of a large ballroom, for example, may be covered by hundreds of stacking-type chairs in an unstacked configuration. However, during cleaning, or when the facility is used for convention purposes, the chairs are usually stacked along the walls of the rooms, in passageways, or in storage areas. Often, the stacks may be 16 or more chairs high, in row after row. The potential fuel load presented by such an array of stacked chairs can be significant. Even lightly padded chairs, with less than 1 kg of combustibles each, may present a challenging fuel package when 5000 or more chairs are stacked in close proximity. It is, therefore, of considerable importance to develop a test procedure that can determine the contribution to a fire of chairs in a stacked configuration.

X1.3.2 The potential for a serious fire from stacked chairs can also be affected by chair design. Many stacking chairs are designed to prevent the bottom of one chair from contacting the top of the chair below it when stacked. It is common for stacking chairs to be structurally designed with a gap of 12 to 100 mm (0.5 to 4 in.) between chair backs and adjacent seating surfaces, when in the stacked configuration. Under these conditions, and from a fire dynamics point of view, stacked chairs create an ideal fuel array for promoting a rapidly developing fire, in a fashion not dissimilar to sticks placed in a fireplace in the form of a well ventilated pile (or array).

X1.3.3 Work on stacking chairs conducted at the California Bureau of Home Furnishings and Thermal Insulation has shown that, when tested individually, stacking chairs often comply with the requirements of severe fire tests such as California Technical Bulletin 133 (described in Test Method E 1537), even though all combustibles are consumed. The criteria referred to are peak heat release rates of less than 80 kW and total heat release values of less than 25 MJ, over the first 10 min of the test. It is apparent, thus, that many stacking chairs, individually, contain insufficient fuel to fail the criteria of tests such as CA TB 133, even when totally destroyed. Thus, when such stacking chairs are used, and stored, individually, there is little concern over their fire behavior, and the potential fire hazard resulting from individual chairs with low fuel load may be acceptable. However, as stated, although stacking chairs are sat upon individually, they are frequently stacked for storage, or when not in use, in a dense fuel configuration. The test results obtained by the California Bureau of Home Furnishings and Thermal Insulation (35) indicate that it is

possible for public facilities to have hundreds of stacking chairs that comply individually with the above heat release criteria, yet which have not been specifically modified for improved fire performance. Under such circumstances, there is a potential for a serious fire, should stacks of chairs become involved.

X1.3.4 A recent study investigated the hazards due to seating furniture fires and the applicability of the full-scale test described here for assessing such fire hazard from individual items of furniture (36), and that has resulted in the promulgation of Test Method E 1537. Similar studies have also been performed for mattresses and bed clothing systems (37,38), and that has resulted in the development of Test Method E 1590. The present test method, thus, addresses one aspect of furniture fires which had not yet been addressed.

X1.4 *Test Facility:*

X1.4.1 It has been determined that the rate of heat release of upholstered furniture in the standard ASTM room (used in Test Configuration A of this test method; 8 by 12 by 8 ft high) and in the room described in CA TB 129 and 133 (used in Test Configuration B of this test method; 10 by 12 by 8 ft high) and in a furniture calorimeter (such as those described in UL 1056, in UL 1895, or in Nordtest NT Fire 032) are similar unless the heat release rate exceeds 600 kW (1). It is of interest that the rate of heat release criteria of CA TB 129 or CA TB 133 can be met by using a furniture calorimeter or a room of different dimensions than the one specified in the test method. This concept has also been incorporated into Test Method E 1537, for real-scale upholstered furniture items and Test Method E 1590, for real scale mattresses.

X1.4.2 It has also been determined that the increase in temperature in the fire room can be represented by the rate of heat release measured in the duct: a rate of heat release of 65 kW is roughly equivalent to an increase in temperature of 111°C (200°F) at a location 25 mm below the ceiling of the room in Test Configuration B of this test method, directly above the burning item (39).

X1.4.3 Current practice recommends that combustion gas measurements be made in the exhaust collection duct. If the gases are all collected by the exhaust system and are properly mixed, such instrumentation offers the possibility of a largely apparatus-independent measurement.

X1.4.4 The variable that is fully independent of (reasonable) variations in magnitudes such as room size, room geometry, and duct air flow rate is the gas yield. For any gas x , the yield is computed as shown in Eq A4.15 and Eq A4.16. If the flow rate is constant, the numerator of this equation is simply the product of the mass flow rate and the time period. This gas yield is nondimensional.

X1.4.5 In order to obtain gas yields it is necessary, thus, to measure mass losses, with a load cell of the burning test specimen, as well as concentrations of the gas species in question.

X1.4.6 An example of the application of gas yields to fire hazard analysis is found in Ref (39).

X1.5 *Ignition Source:*

X1.5.1 It has been determined that a square gas burner ignition source, when used at a propane flow rate of 13 L/min, for 80 s, is an adequate (and more reproducible) substitute for the traditional newspaper ignition source formerly used in CA TB 133 (five sheets of newspaper, each formed into a loose wad, covered by a sheet metal and wire mesh box and ignited with a match) (40). The January 1991 version of CA TB 133 thus relegated the newspaper ignition source to a secondary role as a screening test. There has been no work done to determine the applicability of that square burner defined under any conditions other than those which mirror the CA TB 133 ignition source.

X1.5.2 The burner described in this test method is identical to that used in Test Method E 1590. It has been shown that this burner, when used at a propane gas flow rate of 12 L/min, for 80 s, is adequate for the ignition of stacked chairs (35) and of mattresses, when used for 180 s (38).

X1.5.3 The gas burner defined can, of course, be used at other gas flow rates or for other time periods. However, the range of applicability of such an ignition source has yet to be determined.

X2. Method of Determining Suitability of Oxygen Analyzers for Making Heat Release Measurements

X2.1 *General*—The type of oxygen analyzer best suited for fire gas analysis is of the paramagnetic type. Electrochemical analyzers or analyzers using zirconia sensors have generally been found not to have adequate sensitivity or suitability for this type of work. The normal range of the instrument to be used is 0 to 25 vol % oxygen. The linearity of paramagnetic analyzers is normally better than can be checked by a user laboratory, thus verifying their linearity is not necessary. It is important, however, to confirm the noise and short-term drift of the instrument used.

X2.2 Procedure:

X2.2.1 Connect two different gas bottles having approximately two percentage points apart (15 and 17 vol %) to a selector valve at the inlet of the analyzer.

X2.2.2 Connect the electrical power and let the analyzer warm up for 24 h with one of the test gases from X2.2.1 flowing through it.

X2.2.3 Connect a data acquisition system to the output of the analyzer. Quickly switch from the first gas bottle to the second bottle and immediately start collecting data, taking one data point per second. Collect data for 20 min.

X2.2.4 Determine the drift by using a least-squares analysis fitting procedure to pass a straight line through the last 19 min of data. Extrapolate the line back through the first minute of

data. The difference between the readings at 0 min and at 20 min on the fitted straight line represents the short-term drift. Record the drift in units of parts per million of oxygen.

X2.2.5 The noise is represented by the root-mean-square deviation around the fitted straight line. Calculate the root-mean-square value and record it in units of parts per million of oxygen.

X2.2.6 The analyzer is suitable for use in heat release measurements if the sum of the drift plus the noise terms is ≤ 50 ppm oxygen.

NOTE X2.1—Both terms must be expressed as positive numbers.

X2.3 *Additional Precautions*—A paramagnetic oxygen analyzer is directly sensitive to barometric pressure changes at its outlet port and flow rate fluctuations in the sample supply stream. It is essential that the flow rate be regulated. Use either a flow rate regulator of the mechanical diaphragm type or an electronic mass flow controller. To protect against errors to changes in barometric pressure, one of the following procedures should be used: (a) control the back pressure to the analyzer with a back pressure regulator of the absolute-pressure type, or (b) electrically measure the actual pressure at the detector element and provide a signal correction for the analyzer output.

X3. SMALL SCALE SCREENING OF MATERIALS

X3.1 Studies on the flammability performance of upholstered furniture indicate that bench-scale fire tests are useful for preliminary evaluations of component materials for substitu-

tion purposes. For a complete description of the bench-scale test method, see Test Method E 1474.

X4. TABLES X4.1 THROUGH X4.6 CONTAIN THE INDIVIDUAL RESULTS OF A REPEATABILITY STUDY, WITH SIX SETS OF STACKED CHAIRS IN ONE LABORATORY

X4.1 Chair Set 1—The chair used was a metal-framed chair, with upholstered plastic shell seat and back, and gap. All tests were conducted in Test Configuration C (furniture calorimeter). Test 1A: stack was extinguished at 11.0 min, and data beyond that were discarded. Test 1B: stack was extinguished at 11.0 min, and data beyond that were discarded. Test 1C: stack fell over at 9.5 min and was extinguished at 9.9 min and data beyond that point were discarded. The test endpoint was reached by external extinguishment because flashover appeared inevitable, as required by the test procedure. It is likely that measured values would have been higher than the reported values if the test had not been extinguished externally.

TABLE X4.1 Stacking Chair Test Results—Chair Set 1 (See X4.1)^A

| | Initial Mass, kg | Peak Heat Release Rate, kW | Total Heat Released, MJ | Peak Smoke Release Rate, m ² /s | Total Smoke Released, m ² | Mass Loss, kg | Time to Peak Heat Release Rate, min |
|--------|------------------|----------------------------|-------------------------|--|--------------------------------------|---------------|-------------------------------------|
| Test A | 55.74 | 982 | 39 | 12.6 | 678 | 1.37 | 6.1 |
| Test B | 54.79 | 1624 | 110 | 13.0 | 1377 | 3.98 | 11.0 |
| Test C | 55.49 | 1602 | 81 | 13.2 | 923 | 1.81 | 9.9 |
| Avg | 55.34 | 1403 | 77 | 12.9 | 993 | 2.39 | 9.0 |
| STD | 0.50 | 364 | 36 | 0.3 | 356 | 1.38 | 2.6 |
| RSD% | 1 | 26 | 46 | 2 | 37 | 58 | 29 |

^A The test endpoint was reached by external extinguishment because flashover appeared inevitable, as required by the test procedure. It is likely that measured values would have been higher than the reported values if the test had not been extinguished externally.

TABLE X4.2 Stacking Chair Test Results—Chair Set 2 (See X4.2)

| | Initial Mass, kg | Peak Heat Release Rate, kW | Total Heat Released, MJ | Peak Smoke Release Rate, m ² /s | Total Smoke Released, m ² | Mass Loss, kg | Time to Peak Heat Release Rate, min |
|--------|------------------|----------------------------|-------------------------|--|--------------------------------------|---------------|-------------------------------------|
| Test A | 32.35 | 714 | 269 | 5.1 | 1679 | 5.74 | 9.0 |
| Test B | 32.61 | 661 | 270 | 4.5 | 2066 | 6.10 | 7.5 |
| Test C | 31.50 | 1057 | 288 | 5.9 | 1760 | 4.94 | 5.6 |
| Avg | 32.15 | 810 | 276 | 5.2 | 1835 | 5.59 | 7.4 |
| STD | 0.58 | 215 | 11 | 0.7 | 204 | 0.59 | 1.7 |
| RSD% | 2 | 27 | 4 | 14 | 11 | 11 | 23 |

X4.2 Chair Set 2—The chair used was a metal-framed chair, with plastic shell seat and back, and gap; mixed colors. All tests were conducted in Test Configuration C (furniture calorimeter). Stack 2C: the backs of these chairs ignited sooner than the backs of other chairs.

X4.3 Chair Set 3—The chair used was a metal-framed chair with upholstered seat and back and gap (which differs from that used in Set 4 solely in the absence of a barrier between fabric cover and padding). All tests were conducted in Test Configuration C (furniture calorimeter), except for Test 3A that was conducted in Test Configuration A (3.7 by 2.4 by 2.4 m (12 by 8 by 8 ft) room). Test 3A: tested in Test Configuration A (room) and went to flashover at 10 min; fire

TABLE X4.3 Stacking Chair Test Results—Chair Set 3 (See X4.3)^A

| | Initial Mass, kg | Peak Heat Release Rate, kW | Total Heat Released, MJ | Peak Smoke Release Rate, m ² /s | Total Smoke Released, m ² | Mass Loss, kg | Time to Peak Heat Release Rate, min |
|--------|------------------|----------------------------|-------------------------|--|--------------------------------------|---------------|-------------------------------------|
| Test A | 30.04 | 1089 | 101 | 2.7 | 818 | 5.04 | 10.1 |
| Test B | 30.24 | 567 | 303 | 1.7 | 734 | 12.10 | 12.8 |
| Test C | 29.74 | 603 | 320 | 1.2 | 799 | 13.15 | 9.1 |
| Avg | 30.00 | 585 | 312 | 1.4 | 766 | 12.63 | 11.0 |
| STD | 0.36 | 25 | 11 | 0.7 | 46 | 0.75 | 2.6 |
| RSD% | 1 | 4 | 4 | 14 | 6 | 6 | 24 |

^A Test 3A is not included in the repeatability analysis because a different test configuration was used.

TABLE X4.4 Stacking Chair Test Results—Chair Set 4 (See X4.4)

| | Initial Mass, kg | Peak Heat Release Rate, kW | Total Heat Released, MJ | Peak Smoke Release Rate, m ² /s | Total Smoke Released, m ² | Mass Loss, kg | Time to Peak Heat Release Rate, min |
|--------|------------------|----------------------------|-------------------------|--|--------------------------------------|---------------|-------------------------------------|
| Test A | 30.44 | 278 | 324 | 0.9 | 689 | 12.88 | 29.5 |
| Test B | 30.74 | 323 | 339 | 1.2 | 1128 | 29.80 | 17.5 |
| Test C | 30.19 | 258 | 321 | 0.7 | 1032 | 28.10 | 22.2 |
| Avg | 30.46 | 286 | 328 | 0.9 | 950 | 23.59 | 23.1 |
| STD | 0.28 | 33 | 9 | 0.2 | 231 | 9.32 | 6.0 |
| RSD% | 1 | 12 | 3 | 24 | 24 | 39 | 26 |

TABLE X4.5 Stacking Chair Test Results—Chair Set 5 (See X4.5)^A

| | Initial Mass, kg | Peak Heat Release Rate, kW | Total Heat Released, MJ | Peak Smoke Release Rate, m ² /s | Total Smoke Released, m ² | Mass Loss, kg | Time to Peak Heat Release Rate, min |
|--------|------------------|----------------------------|-------------------------|--|--------------------------------------|---------------|-------------------------------------|
| Test A | 42.32 | 1048 | 366 | 3.0 | 769 | 19.78 | 14.9 |
| Test B | 41.49 | 1082 | 296 | 1.8 | 525 | 15.16 | 13.9 |
| Test C | 39.70 | 942 | 237 | 1.9 | 617 | 14.61 | 13.3 |
| Avg | 41.17 | 1024 | 299 | 2.2 | 637 | 16.52 | 14.0 |
| STD | 1.34 | 73 | 64 | 0.7 | 123 | 2.84 | 0.8 |
| RSD% | 3 | 7 | 21 | 29 | 19 | 17 | 6 |

^A The test endpoint was reached by external extinguishment because flashover appeared inevitable, as required by the test procedure. It is likely that measured values would have been higher than the reported values if the test had not been extinguished externally.

was extinguished at 10.5 min. The data from this test are not included in the repeatability analysis. This chair is an example of stacks for which there will be a difference in test results depending on the test configuration used.

X4.4 Chair Set 4—The chair used was a metal-framed chair, with upholstered plastic shell seat and back, and gap, identical to that used in Stack 3, except for the added barrier between cover fabric and padding. All tests were conducted in Test Configuration C (furniture calorimeter). Test 4B: backs of these chairs ignited sooner than backs of other chairs.

X4.5 Chair Set 5—The chair used was a metal-framed chair, with upholstered seat and back; plus plastic seat cap. All

TABLE X4.6 Stacking Chair Test Results—Chair Set 6 (See X4.6)

| | Initial Mass, kg | Peak Heat Release Rate, kW | Total Heat Released, MJ | Peak Smoke Release Rate, m ² /s | Total Smoke Released, m ² | Mass Loss, kg | Time to Peak Heat Release Rate, min |
|--------|------------------|----------------------------|-------------------------|--|--------------------------------------|---------------|-------------------------------------|
| Test A | 36.74 | 1150 | 300 | 7.4 | 2074 | 7.58 | 7.5 |
| Test B | 37.29 | 1099 | 314 | 8.2 | 2425 | 7.24 | 9.5 |
| Test C | 36.67 | 963 | 291 | 7.5 | 2255 | 7.37 | 7.3 |
| Avg | 36.90 | 1071 | 302 | 7.7 | 2251 | 7.40 | 8.1 |
| STD | 0.34 | 97 | 12 | 0.4 | 176 | 0.17 | 1.2 |
| RSD% | 1 | 9 | 4 | 5 | 8 | 2 | 15 |

tests were conducted in Test Configuration C (furniture calo-

rimeter). Test 5A: stack fell over at 18.1 min, and data beyond that point were discarded. Test 5B: stack fell over at 14.8 min and data beyond that point were discarded. Test 5C: stack fell over at 14.3 min, and data beyond that point were discarded. The test endpoint was reached by external extinguishment because flashover appeared inevitable, as required by the test procedure. It is likely that measured values would have been higher than the reported values if the test had not been extinguished externally.

X4.6 *Chair Set 6*—The chair used was a metal-framed chair, plastic shell seat and back, and gap; single color. All tests were conducted in Test Configuration C (furniture calorimeter).

REFERENCES

- (1) Parker, W. J., Tu, K.-M., Nurbakhsh, S., and Damant, G. H., "Furniture Flammability: An Investigation of the California Technical Bulletin 133 Test. Part III: Full Scale Chair Burns," *NISTIR 90-4375*, 1990.
- (2) Coaker, A. W., Hirschler, M. M., Shakir, S., and Shoemaker, C. L., "Flammability Testing of New Vinyl Compounds with Low Flammability and Low Smoke Release in Cables," *Proceedings of the 39th International Wire and Cable Symposium*, Nov. 13–15, Reno, NV, U.S. Army CECOM, Fort Monmouth, NJ, 1990, pp. 643–654.
- (3) Coaker, A. W., Hirschler, M. M., and Shoemaker, C. L., "Rate of Heat Release Testing for Vinyl Wire and Cable Materials with Reduced Flammability and Smoke: Full Scale Cable Tray Tests and Small Scale Tests," *Fire Safety Journal*, Vol 19, 1992, pp. 19–53.
- (4) Ostman, B., "Comparison of Smoke Release from Building Products," *Int. Conf. FIRE, Control the Heat...Reduce the Hazard*, London, UK, Oct. 24–25, 1988, Fire Research Station, UK, *Paper 8*.
- (5) Mikkola, E., (VTI, Finland), *First International Cone Calorimeter Users' Seminar and Workshop*, London, UK, Jan. 19, 1990.
- (6) Thornton, W., "The Relation of Oxygen to the Heat of Combustion of Organic Compounds," *Philosophical Magazine and Journal of Science*, Vol 33, No. 196, 1917.
- (7) Huggett, C., "Estimation of Rate of Heat Release by Means of Oxygen Consumption Measurements," *Fire and Materials*, Vol 4, 1980, pp. 61–65.
- (8) Parker, W., "An Investigation of the Fire Environment in the ASTM E-84 Tunnel Test," *NBS Technical Note 945*, 1977.
- (9) Sensenig, D., "An Oxygen Consumption Technique for Determining the Contribution of Interior Wall Finishes to Room Fires," *NBS Technical Note 1182*, 1980.
- (10) Parker, W., "Calculations of the Heat Release Rate by Oxygen Consumption for Various Applications," *NBSIR 812-2427-1*, 1982.
- (11) Babrauskas, V., "Development of the Cone Calorimeter—A Bench-Scale Rate of Heat Release Apparatus Based on Oxygen Consumption," *NBSIR 82-2611*, 1982.
- (12) Babrauskas, V., Lawson, J., Walton, W., and Twilley, W., "Upholstered Furniture Heat Release Rates Measured with the Furniture Calorimeter," *NBSIR 82-2604*, 1983.
- (13) ASTM, "Proposed Method for Room Fire Test of Wall and Ceiling Materials and Assemblies," *Annual Book of ASTM Standard*, Vol 04.07, 1983.
- (14) ASME, "Fluid Meters—Their Theory and Applications," *Report of the ASME Committee on Fluid Meters*, H. Bean, ed., Sixth ed., 1971.
- (15) Ower, E., and Pankhurst, R., "The Measurement of Air Flow," Pergamon Press, 5th ed., 1977, pp. 112–147.
- (16) McCaffrey, B., and Heskestad, G., *Combustion and Flame*, Vol 26, 1976, pp. 125–127.
- (17) Janssens, M. L., "Measuring Rate of Heat Release by Oxygen Consumption," *Fire Technology*, Vol 27, 1991, pp. 234–249.
- (18) Babrauskas, V., Lawson, J., Walton, W., and Twilley, W., "Upholstered Furniture Heat Release Rates Measured with the Furniture Calorimeter," *NBSIR 82-2604*, 1983.
- (19) Thomas, P. H., "Int. Conf. FIRE: Control the Heat...Reduce the Hazard," October 24–25, 1988, London, UK, *QMC Fire and Materials Centre, Paper 1*.
- (20) Babrauskas, V., "Int. Conf. FIRE: Control the Heat...Reduce the Hazard," October 24–25, 1988, London, UK, *QMC Fire and Materials Centre, Paper 4*.
- (21) Babrauskas, V., and Peacock, R. D., "Heat Release Rate. The Single Most Important Variable in Fire Hazard," *Fire Retardant Chemicals Association 1990 Fall Technical Meeting*, Pontevedra Beach, FL, Oct. 22–24, 1990.
- (22) Hirschler, M. M., "How to Measure Smoke Obscuration in a Manner Relevant to Fire Hazard Assessment: Use of Heat Release Calorimetry Test Equipment," *Journal of Fire Sciences*, Vol 9, 1991, pp. 183–222.
- (23) Tran, H., "Experimental Data on Wood Materials," *Heat Release in Fires*, Chapter 11 b, Elsevier, London, UK, V. Babrauskas and S. J. Grayson, eds., 1992, pp. 357–373.
- (24) Hirschler, M. M., "Heat Release from Plastic Materials," *Heat Release in Fires*, Chapter 12 a, Elsevier, London, UK, V. Babrauskas and S. J. Grayson, eds., 1992, pp. 375–422.
- (25) Babrauskas, V., and Grayson, S. J., (Editors), "Heat Release in Fires," Elsevier, London, UK, 1992.
- (26) Huggett, C., "Estimation of Rate of Heat Release by Means of Oxygen Consumption Measurements," *Fire and Materials*, Vol 4, 1980, pp. 61–65.
- (27) Parker, W. J., "Calculations of the Heat Release Rate by Oxygen Consumption for Various Applications," *NBSIR 82-2427-1*, 1982.
- (28) Parker, W. J., "Calculations of the Heat Release Rate by Oxygen Consumption for Various Applications," *Journal of Fire Sciences*, Vol 2, September/October 1984, pp. 380–395.
- (29) Hirschler, M. M., "General Principles of Fire Hazard and the Role of Smoke Toxicity," in "Fire and Polymers: Hazards Identification and Prevention," (Ed. G. L. Nelson), *ACS Symposium Series 425*, Developed from Symp. at 197th ACS Mtg, Dallas, TX, April 9–14, 1989, *Amer. Chem. Soc.*, Washington, DC, Chapter 28, 1990, pp. 462–478.
- (30) Debanne, S. M., Hirschler, M. M., and Nelson, G. L., "The Importance of Carbon Monoxide in the Toxicity of Fire Atmospheres," San Antonio, TX, "Fire Hazard and Fire Risk Assessment," *ASTM STP 1150*, ASTM, Philadelphia, PA, M. M. Hirschler, ed., pp. 9–23.

- (31) Woolley, W. D., Raftery, M. M., Ames, S. A., and Pitt, A. I., "Behaviour of Stacking Chair in Fire Tests," *Fire International*, Vol 6, No. 66, 1979, pp. 66–86.
- (32) Paul, K. T., "Demonstration of the Effect of Softening and Fire Resistance of Materials on Burning Characteristics," *Fire and Materials*, Vol 4, 1980, pp. 83–86.
- (33) Babrauskas, V., "Will the Second Item Ignite?" *Fire Safety Journal*, Vol 4, 1981/1982, pp. 281–292.
- (34) Irjala, B.-L., "Rate of Heat Release of Furniture," *12th International Conference Fire Safety*, Jan. 12–16, 1987, Ed. C. J. Hilado, Prod. Safety Corp., San Francisco, CA, 1987, pp. 32–43.
- (35) Nurbakhsh, S., and Damant, G. H., "Development of a Test Method for the Flammability of Stacking Chairs," *19th International Conference Fire Safety*, Jan. 10–14, 1994, Ed. C. J. Hilado, Prod. Safety Corp., San Francisco, CA, 1994, pp. 32–58.
- (36) Quintiere, J. G., "Furniture Flammability: An Investigation of the California Technical Bulletin 133 Test. Part I: Measuring the Hazards of Furniture," *NISTIR 90-4360*, 1990.
- (37) Damant, G. H., Nurbakhsh, S., and Mikami, J., "Fire Tests of Mattresses for College Dormitories," *California Department of Home Furnishings and Thermal Insulation*, June 1991.
- (38) Damant, G. H., and Nurbakhsh, S., "Heat Release Tests of Mattresses and Bedding Systems," *Journal of Fire Sciences*, Vol 10, 1992, pp. 386–410.
- (39) Babrauskas, V., Harris, R. H., Braun, E., Levin, B. C., Paabo, M., and Gann, R. G., "The Role of Bench-Scale Data in Assessing Real-Scale Fire Toxicity," *NIST Technical Note No. 1284*, National Inst. Standards Technology, Gaithersburg, MD, 1991.
- (40) Ohlemiller, T. J., and Villa, K., "Furniture Flammability: An Investigation of the California Technical Bulletin 133 Test, Part II: Characterization of the Ignition Source and a Comparable Gas Burner," *NISTIR 90-4348*, 1990.

ASTM International takes no position respecting the validity of any patent rights asserted in connection with any item mentioned in this standard. Users of this standard are expressly advised that determination of the validity of any such patent rights, and the risk of infringement of such rights, are entirely their own responsibility.

This standard is subject to revision at any time by the responsible technical committee and must be reviewed every five years and if not revised, either reapproved or withdrawn. Your comments are invited either for revision of this standard or for additional standards and should be addressed to ASTM International Headquarters. Your comments will receive careful consideration at a meeting of the responsible technical committee, which you may attend. If you feel that your comments have not received a fair hearing you should make your views known to the ASTM Committee on Standards, at the address shown below.

This standard is copyrighted by ASTM International, 100 Barr Harbor Drive, PO Box C700, West Conshohocken, PA 19428-2959, United States. Individual reprints (single or multiple copies) of this standard may be obtained by contacting ASTM at the above address or at 610-832-9585 (phone), 610-832-9555 (fax), or service@astm.org (e-mail); or through the ASTM website (www.astm.org).