



Standard Test Method for Fire-Resistive Joint Systems¹

This standard is issued under the fixed designation E 1966; the number immediately following the designation indicates the year of original adoption or, in the case of revision, the year of last revision. A number in parentheses indicates the year of last reapproval. A superscript epsilon (ϵ) indicates an editorial change since the last revision or reapproval.

INTRODUCTION

Joint systems are positioned in joints, voids, gaps, or other discontinuities between or bounded by two or more supporting elements. Normally such openings are denoted as “linear” because the length is greater than their width—defined by a typical ratio of at least 10:1 as in practice. Joints are present in buildings as a result of:

- (i) Design to accommodate various movements induced by thermal differentials, seismicity, and wind loads and exist as a clearance separation.
- (ii) Acceptable dimensional tolerances between two or more building elements, for example, between non-loadbearing walls and floors.
- (iii) Inadequate design, inaccurate assembly, repairs or damage to the building.

1. Scope

1.1 This fire-test-response test method measures the performance of joint systems designed to be used with fire rated floors and walls during a fire endurance test exposure. The fire endurance test end point is the period of time elapsing before the first performance criteria is reached when the joint system is subjected to one of two time-temperature fire exposures.

1.2 The fire exposure conditions used are either those specified by Test Method E 119 for testing assemblies to standard time-temperature exposures or Test Method E 1529 for testing assemblies to rapid-temperature rise fires.

1.3 This test method specifies the heating conditions, methods of test, and criteria for the evaluation of the ability of a joint system to maintain the fire resistance where hourly rated fire-separating elements meet.

1.4 Test results establish the performance of joint systems during the fire-exposure period and shall not be construed as having determined the joint systems suitability for use after that exposure.

1.5 This test method does not provide quantitative information about the joint system relative to the rate of leakage of smoke or gases or both. However, it requires that such phenomena be noted and reported when describing the general behavior of joint systems during the fire endurance test but is not part of the conditions of compliance.

1.6 Potentially important factors and fire characteristics not addressed by this test method include, but are not limited to:

1.6.1 The performance of the fire-resistive joint system

constructed with components other than those tested.

1.6.2 The cyclic movement capabilities of joint systems other than the cycling conditions tested.

1.7 The values stated in inch-pound units are to be regarded as the standard. The SI values given in parentheses are for information only.

1.8 The text of this standard references notes and footnotes which provide explanatory material. These notes and footnotes (excluding those in tables and figures) shall not be considered as requirements of the standard.

1.9 *This standard is used to measure and describe the response of materials, products, or assemblies to heat and flame under controlled conditions, but does not by itself incorporate all factors required for fire hazard or fire risk assessment of the materials, products, or assemblies under actual fire conditions.*

1.10 *This standard does not purport to address all of the safety concerns, if any, associated with its use. It is the responsibility of the user of this standard to establish appropriate safety and health practices and determine the applicability of regulatory limitations prior to use.*

2. Referenced Documents

2.1 ASTM Standards:

E 84 Test Method for Surface Burning Characteristics of Building Materials²

E 119 Test Methods for Fire Tests of Building Construction and Materials²

E 176 Terminology of Fire Standards²

E 631 Terminology of Building Constructions³

¹ This test method is under the jurisdiction of ASTM Committee E-5 on Fire Standards and is the direct responsibility of Subcommittee E05.11 on Fire Endurance.

Current edition approved July 10, 2000. Published October 2000. Originally published as E 1966–98. Last previous edition E 1966–99.

² *Annual Book of ASTM Standards*, Vol 04.07.

³ *Annual Book of ASTM Standards*, Vol 04.11.

E 1529 Test Methods for Determining Effects of Large Hydrocarbon Pool Fires on Structural Members and Assemblies²

2.2 *Other Documents:*

UL 385 Standard for Play Pipes for Water Supply Testing in Fire-Protection Service⁴

3. Terminology

3.1 For the purpose of this standard, the definitions given in Terminologies E 176 and E 631, together with the following, apply:

3.1.1 *fire-separating element, n*—floors, walls, and partitions having a period of fire resistance determined in accordance with Test Methods E 119 or E 1529.

3.1.2 *fire resistive joint system, n*—a device or designed feature that provides a fire separating function along continuous linear openings, including changes in direction, between or bounded by fire separating elements.

3.1.3 *joint, n*—the linear void located between juxtaposed fire-separating elements.

3.1.4 *maximum joint width, n*—the widest opening of an installed joint system.

3.1.5 *minimum joint width, n*—the narrowest opening of an installed joint system.

3.1.6 *movement cycle, n*—the change between the minimum and the maximum joint widths of a joint system.

3.1.7 *nominal joint width, n*—the specified opening of a joint in practice that is selected for test purposes.

3.1.8 *splice, n*—the connection or junction within the length of a joint system.

3.1.9 *supporting construction, n*—the arrangement of building sections forming the fire-separating elements into which the joint systems are installed.

3.1.10 *test assembly, n*—the complete assembly of test specimens together with their supporting construction.

3.1.11 *test specimen, n*—a joint system of a specific material(s), design, and width.

4. Summary of Test Method

4.1 This test method describes the following test sequence and procedure:

4.1.1 When the maximum joint width does not equal the minimum joint width, joint systems shall be movement cycled before being fire tested.

4.1.2 Joint systems and their supporting construction shall be conditioned and fire tested.

4.1.3 A duplicate test specimen, that is an extension of a wall, is subject to a fire of lesser duration than the fire endurance rating. After which, the duplicate test specimen is subject to the hose stream test.

5. Significance and Use

5.1 This test method evaluates, under the specified test conditions: (1) the ability of a fire resistive joint system to undergo movement without reducing the fire rating of the adjacent fire separating elements and (2) the duration for which

test specimens will contain a fire and retain their integrity during a predetermined test exposure.

5.2 This test method provides for the following measurements and evaluations where applicable:

5.2.1 Capability of the joint system to movement cycle.

5.2.2 Loadbearing capacity of the joint system.

5.2.3 Ability of the joint system to prohibit the passage of flames and hot gases.

5.2.4 Transmission of heat through the joint system.

5.2.5 Ability of the joint system, that is an extension of a wall, to resist the passage of water during a hose stream test.

5.3 This test method does not provide the following:

5.3.1 Evaluation of the degree by which the joint system contributes to the fire hazard by generation of smoke, toxic gases, or other products of combustion.

5.3.2 Measurement of the degree of control or limitation of the passage of smoke or products of combustion through the joint system.

5.3.3 Measurement of flame spread over the surface of the joint system.

NOTE 1—The information in 5.3.1-5.3.3 may be determined by other suitable fire test methods. For example, 5.3.3 may be determined by Test Method E 84.

5.3.4 Evaluation of joints formed by the rated or non-rated exterior walls and the floors of the building.

5.4 In this procedure, the test specimens are subjected to one or more specific sets of laboratory test conditions. When different test conditions are substituted or the end-use conditions are changed, it is not always possible by, or from, this test method to predict changes to the characteristics measured. Therefore, the results are valid only for the exposure conditions described in this test method.

6. Apparatus

6.1 *Cycling Apparatus*—Equipment (or device) capable of being used to induce movement of a joint system and meeting the required cyclic rate and number of cycles selected from Table 1.

6.2 *Furnace*—An enclosed furnace facility capable of controlling a fire to the time-temperature curve in Test Methods E 119 or E 1529. An example of a vertical furnace with a test frame is shown in Fig. 1 and a horizontal furnace is shown in Fig. 2.

6.3 *Furnace Thermocouples:*

6.3.1 The E 119 furnace thermocouples shall:

6.3.1.1 Be protected by sealed porcelain tubes having a nominal 3/4-in. (19-mm) outside diameter and 1/8-in. (3-mm)

TABLE 1 Conditions of Test Specimen Cycling

NOTE 1—The terms used for movement are indicative of the cyclic rate in expansion and contraction of the joint system and not of the magnitude or direction of movement.

Movement Type	Minimum Cycling Rates (cpm)	Minimum Number of Movement Cycles
Thermal	1	500
Wind Sway	10	500
Seismic	30	100
Combined Movement	30	100
followed by:	10	400

⁴ Underwriters Laboratories, 333 Pfingston Road, Northbrook, IL 60062.

- 1. Furnace
- 2. Exhaust Flue
- 3. View Ports
- 4. Gas Burners
- 5. Thermocouple Tubes
- 6. Test Frame
- 7. Test Specimen Location
- 8. Loading Jacks (when required)

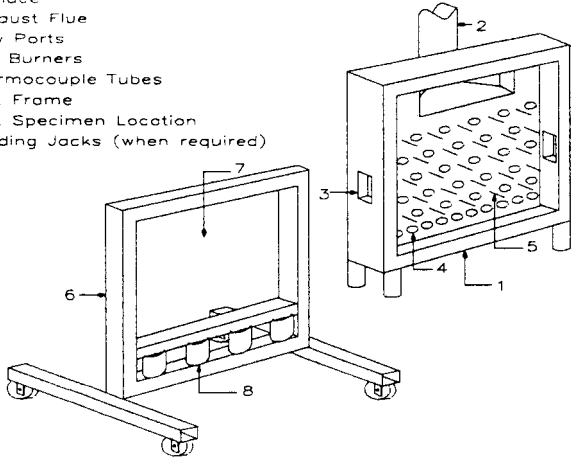

FIG. 1 Example of Vertical Furnace and Test Frame

- 1. Furnace
- 2. Exhaust Flue
- 3. View Ports
- 4. Access Door
- 5. Gas Burners
- 6. Thermocouple Tube Locations
- 7. Test Specimen Location

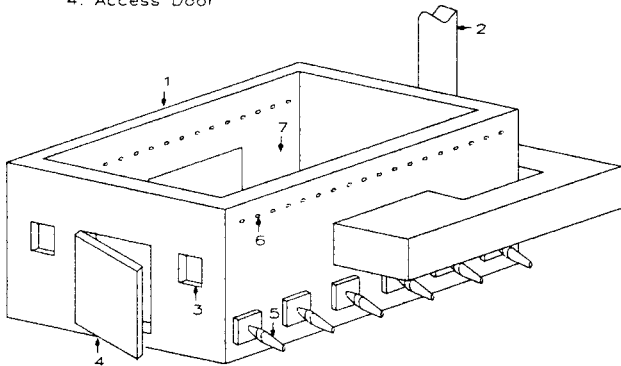

FIG. 2 Example of Horizontal Furnace

wall thickness, or, as an alternative, in the case of base metal thermocouples, protected by a standard 1/2-in. (13-mm) diameter wrought steel or wrought iron pipe of standard weight, and 6.3.1.2 Have a time constant between the range of 5.0 to 7.2 min while encased in the tubes described in 6.3.1.1.

6.3.2 Other types of E 119 protection tubes or pyrometers shall be used only when they give the same indications under test conditions as those of 6.3.1.2 within the limit of accuracy that applies for furnace-temperature measurements.

NOTE 2—A typical thermocouple assembly meeting these time constant requirements may be fabricated by fusion-welding the twisted ends of No. 18 gage Chromel-Alumel wires, mounting the leads in porcelain insulators and inserting the assembly so the thermocouple bead is approximately 0.5 in. (25 mm) from the sealed end of the standard weight nominal 1/2-in. (25-mm) iron, steel, or Inconel⁵ pipe. The time constant for this and for several other thermocouple assemblies was measured in 1976. The time constant may also be calculated from knowledge of its physical and thermal properties.⁶

6.3.3 The E 1529 furnace thermocouples shall measure the temperature of the gases adjacent to and impinging on the test specimens using factory manufactured 1/4-in. (6-mm) outside diameter (OD), Inconel-sheathed, Type K, Chromel-Alumel thermocouples. The time constant, in air, of the thermocouple assemblies shall be less than 60 s. Standard calibration thermocouples with an accuracy of $\pm 0.75\%$ shall be used.

6.4 *Pressure-sensing Probes*—Where applicable, tolerances are $\pm 5\%$ of dimensions shown in Fig. 3 or Fig. 4.

6.4.1 The pressure-sensing probes shall be either:

6.4.1.1 A T-shaped sensor as shown in Fig. 3, or

6.4.1.2 A tube sensor as shown in Fig. 4.

⁵ Inconel is a registered trade name of INCO Alloys, Inc., 3800 Riverside Dr., Huntington, WV 25720.

⁶ Supporting data is available from ASTM Headquarters. Request RR: E05-1001.

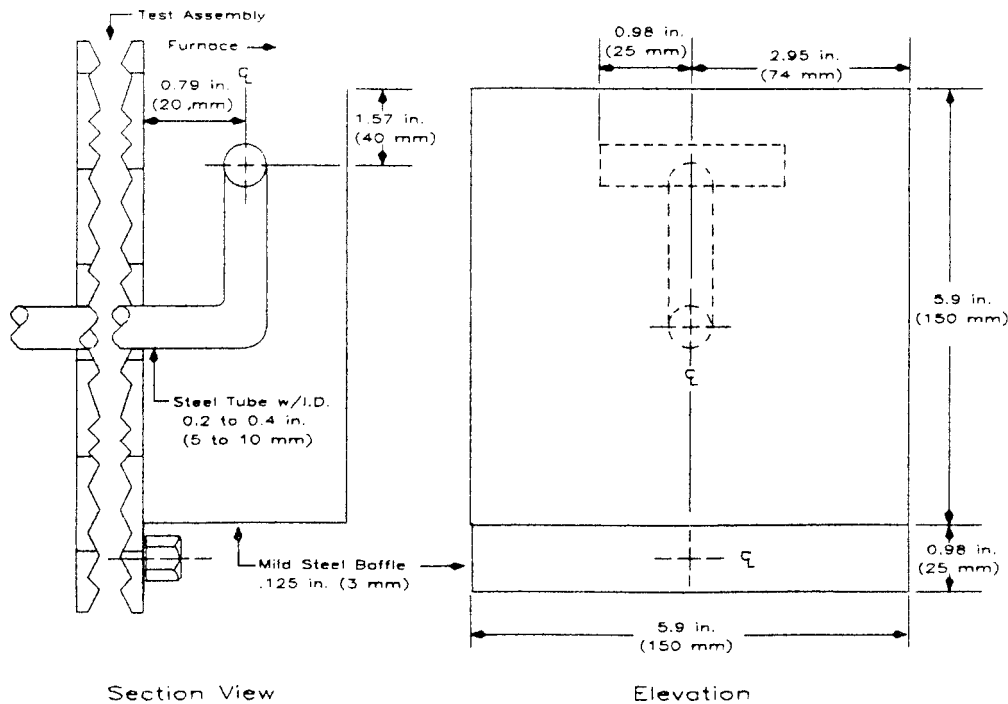

FIG. 3 "T" Shaped Pressure Sensing Probe

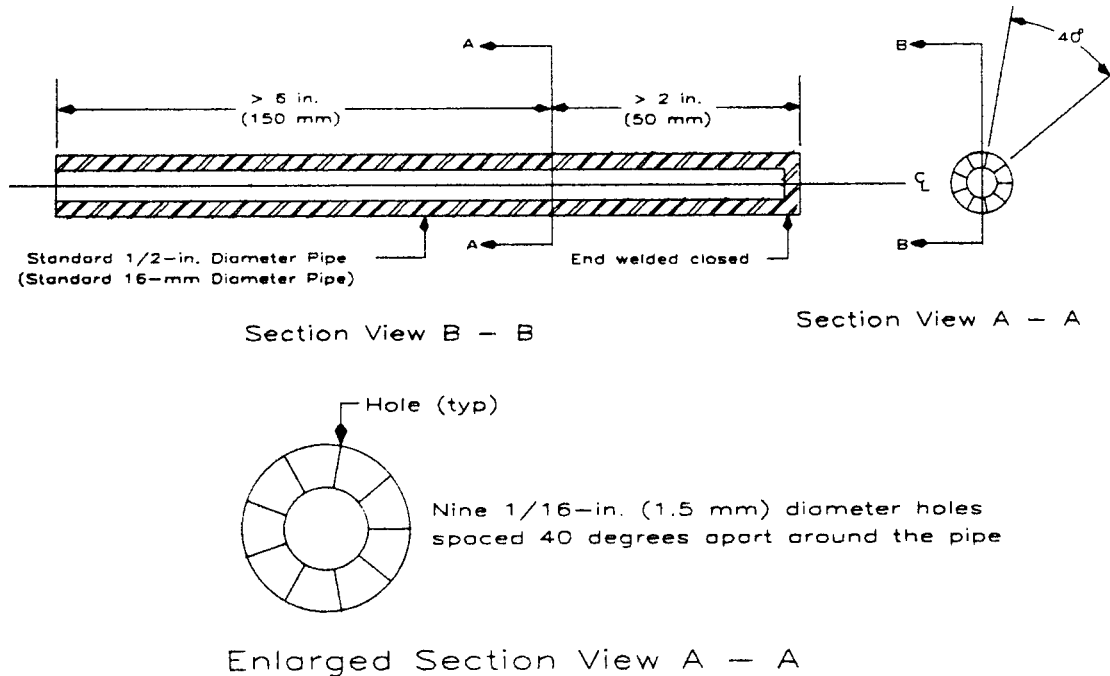

FIG. 4 Tube Type Pressure Sensing Probe

6.5 Unexposed Surface Thermocouples:

6.5.1 The wires for the unexposed thermocouple in the length covered by the thermocouple pad are not to be heavier than No. 18 AWG (0.82 mm²) and are to be electrically insulated with heat-resistant and moisture-resistant coatings.

6.6 Thermocouple Pads:

6.6.1 The properties of thermocouple pads used to cover each thermocouple on the unexposed side of the test assembly shall have the following characteristics.

6.6.1.1 They shall be dry, felted refractory fiber pads.

6.6.1.2 For joints having a maximum joint width of less than 6 in. (152 mm) the length and width of the square pad shall measure 2 ± 0.04 in. (50 ± 1 mm). For joints having a maximum joint width equal to or greater than 6 in. (152 mm) the length and width of the square pad shall measure 6 ± 0.12 in. (152 ± 3 mm).

6.6.1.3 The thermocouple pads shall be 0.375 ± 0.063 in. (9.5 ± 1.6 mm) thick. The thickness measurement is to be made under the light load of a standard 1/2-in. (12.7-mm) diameter pad of a dial micrometer gauge.

6.6.1.4 The thermocouple pads shall have a density of 31.2 ± 0.6 lbs/ft³ (500 ± 10 kg/m³).

6.6.1.5 The thermal conductivity of the thermocouple pads at 150°F (66°C) shall be 0.37 ± 0.03 Btu · in./h · ft² · °F [0.053 ± 0.004 W/(m · K)].

6.6.1.6 The thermocouple pads shall have a hardness (on soft face) of 2.25 to 4.5 (modified Brinnell). The hardness measurement is to be made by pressing a standard 1-in. (25-mm) diameter steel ball against the specimen and measuring the indentation obtained between a minor load of 2 pounds-mass (0.91 kg) and an additional major load of 10 pounds-mass (4.5 kg) [12 pounds-mass (5.4 kg) total load]. The hardness is obtained by the relationship:

$$\text{Hardness} = 2.24/y$$

where:

y = the difference in indentation [in. (mm)].

6.7 Differential Pressure Measurement Instruments:

6.7.1 The differential pressure measurement instrument shall be:

6.7.1.1 A manometer or equivalent transducer.

6.7.1.2 Capable of reading in graduated increments of no greater than 0.01 in H₂O (2.5 Pa) with a precision of not less than ± 0.005 in. H₂O (± 1.25 Pa).

6.8 Cotton Pads:

6.8.1 Their nominal size shall be 4 by 4 by 3/4 in. (100 by 100 by 19 mm). Cotton pads are to consist of new, undyed and soft cotton fibers, without any admixture of artificial fibers. Each cotton pad is to weigh approximately 3 to 4 g. The cotton pads are to be conditioned prior to use by drying in an oven at 212 ± 9°F (100 ± 5°C) for at least 30 min. After drying, the cotton pads shall be stored in a desiccator for up to 24 h.

6.8.2 The frame used to hold the cotton pad is to be formed of No. 16 AWG (1.31-mm) steel wire and is to be provided with a handle long enough to reach all points of the test assembly.

6.9 Loading System:

6.9.1 Equipment, or a device, capable of inducing a desired load upon the joint system or supporting construction. An example of a loading system is shown in Fig. 5.

6.10 Hose Stream Delivery System:

6.10.1 The hose stream delivery system shall consist of:

6.10.1.1 A standard 2 1/2-in. (64-mm) diameter hose attached to a national standard play pipe as described in UL 385.

6.10.1.2 The play pipe shall have a length of 30 ± 0.25 in. (762 ± 6 mm) and shall be equipped with a standard 1 1/8-in. (29-mm) discharge tip of the standard-taper-smooth-bore pattern without shoulder at the orifice.

1. Steel "I" Beam
2. Pneumatic or Hydraulic Cylinders
3. Universal Clamping Joint
4. Variable Size Base

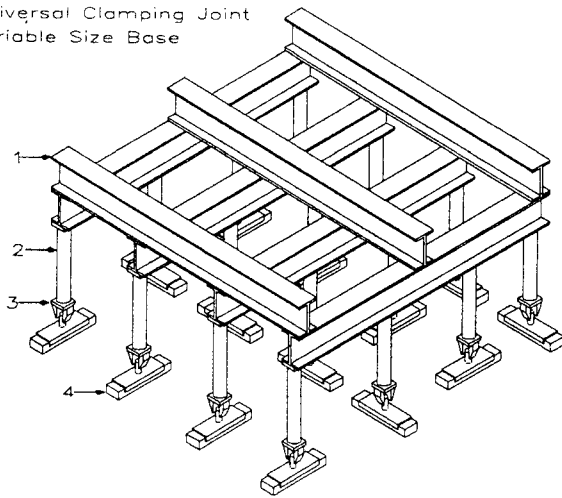

FIG. 5 Example of Loading System

6.10.1.3 The play pipe shall be fitted with a standard 2 1/2-in. (64-mm) inside dimension by 6-in. (153-mm) long nipple mounted between the hose and the base of the play pipe.

6.10.1.4 A pressure tap for measuring the water pressure at the base of the nozzle shall be normal to the surface of the nipple, shall be centered in its length, and shall not protrude into the water stream.

6.10.1.5 A suitable pressure gage capable of reading a minimum of 0-50 psi (0-344.8 kPa) and graduated into no greater than 2-psi (13.8-kPa) increments shall be used to measure the water pressure.

7. Test Specimen

7.1 Make the test assembly representative of the construction for which the fire endurance rating is desired with respect to materials, workmanship, and details. Install the test specimen in accordance with the manufacturer's specified procedure for conditions representative of those found in building construction.

7.2 A test assembly often consists of multiple test specimen widths, joint configurations, test specimen configurations, supporting elements, and joint face materials. When multiple test specimens are installed and tested simultaneously in a test assembly, maintain the separation between adjacent test specimens to accommodate thermocouple placement and structural and loading requirements.

7.3 Test each test specimen with manufactured and field splices. When the technique of the manufactured splice is the same as the field splice, test only one splice. Make the minimum distance between a splice and the nearest furnace wall 1.5 times the thickness of the supporting construction or 12 in. (305 mm) whichever is greater. Make the minimum separation between splices within a test specimen 36 in. (914 mm). Position splices so that they will be exposed to a minimum positive furnace pressure differential of 0.01 in H₂O (2.5 Pa) during the fire exposure test.

7.4 Test all test specimens at their maximum joint width.

7.5 Test vertical asymmetrical test specimens from both sides unless they are designed for fire exposure on only one

side or it is documented that the side with the lower fire endurance rating is being tested.

7.6 Make vertical and horizontal test specimens with a maximum joint width not greater than 4 in. (102 mm) at least 4 ft (1219 mm).

7.7 For maximum joint widths greater than 4 in. (102 mm), make the vertical test specimens at least 9 ft (2744 mm) and make the horizontal test specimens at least 12 ft (3658 mm).

8. Preparation of Apparatus

8.1 Furnace Thermocouples:

8.1.1 *Test Method E 119*—Make the exposed length of the pyrometer tube and thermocouple in the furnace chamber not less than 12 in. (305 mm).

8.1.2 *Test Method E 1529*—Mount a minimum length of 20 diameters (125 mm) of the sheathed junction end of the thermocouple parallel to the surface of the test specimen.

8.2 Furnace Thermocouple Locations:

8.2.1 Uniformly distribute the thermocouples employed to measure the temperature of the furnace to give the average temperature in the vicinity of the test specimen. Reference 6.3.

8.2.2 Position the furnace thermocouples before the start of the fire exposure test. If a thermocouple will come in contact with or will touch the test assembly during the test, reposition that thermocouple to avoid any contact with the test assembly.

8.2.3 Place the junction of each thermocouple 12 ± 1 in. (305 ± 25 mm) from the surface of horizontal construction or from the surface of specimens mounted in horizontal test assemblies.

8.2.4 Place the junction of each thermocouple 6 ± 1 in. (152 ± 25 mm) from the surface of vertical assemblies or from the surface of test specimen mounted in vertical test assembly.

8.2.5 Use a minimum of three furnace thermocouples. For the following, calculate the exposed area as the sum of the surface area of the test assembly exposed to the furnace fire.

8.2.5.1 For horizontal assemblies, place no less than five thermocouples per 100 ft² (9 m²) of exposed area.

8.2.5.2 For vertical assemblies, place no less than nine thermocouples per 100 ft² (9 m²) of exposed area.

8.3 Furnace Pressure:

8.3.1 Make the minimum vertical distance between pressure sensors referenced in 6.4 one-half the height of the furnace chamber. Locate the pressure sensors where they will not be subjected to direct impingement of convection currents. Make tubing connected to each pressure sensor horizontal both in the furnace and at its egress through the furnace wall such that the pressure is relative to the same elevation from the inside to the outside of the furnace.

8.3.2 For horizontal furnaces, measure the differential pressure near the vertical centerline of two opposing furnace walls.

8.3.3 For vertical furnaces, measure the differential pressure along the furnace wall near each side of the furnace.

9. Calibration and Standardization

9.1 Test Method E 119 does not contain a calibration procedure.

9.2 Test Method E 1529 calibration procedure is as follows:

9.2.1 Expose a test specimen to heat flux and temperature conditions representative of total continuous engulfment in the

luminous flame regime of a large free burning fluid hydrocarbon fueled pool fire. Use calibration assemblies to demonstrate that the required heat flux and temperature levels are generated in the fire test facility.

9.2.2 Measure the total heat flux using a circular foil heat flux gage.

NOTE 3—The circular foil heat flux gage may be called a Gardon gage after its developer.

9.2.3 Provide a test setup with an average total cold wall heat flux on all exposed surfaces of the test specimen of $50\,000 \pm 2\,500$ Btu/ft²·h (158 ± 8 kW/m²). Control the total cold wall heat flux by varying the flow of fuel and air. Attain the cold heat flux of $50\,000$ Btu/ft²·h (158 ± 8 kW/m²) within the first 5 min of the test exposure; maintain this heat flux for the duration of the test.

9.2.4 Generate a temperature environment with a heat flux of $50\,000$ Btu/ft²·h of at least 1500°F (815°C) after the first 3 min of the test and between 1850°F (1010°C) and 2150°F (1180°C) at all times after the first 5 min of the test.

10. Conditioning

10.1 Prior to testing, condition the supporting construction and test specimen in air having 50 % relative humidity at $73 \pm 5^\circ\text{F}$ ($23 \pm 3^\circ\text{C}$). Do not require the supporting construction to be conditioned with the test specimen. When conditioning to this level cannot be accomplished, conduct the testing when the most damp portion of the supporting construction and test specimen have achieved equilibrium resulting from storage in air having 50 % to 75 % relative humidity at $73 \pm 5^\circ\text{F}$ ($23 \pm 3^\circ\text{C}$).

10.1.1 *Exception*—When an equilibrium condition is not achieved within a 12-month conditioning period; or if the test assembly is such that hermetic sealing resulting from the conditioning has prevented drying of the interior of the supporting construction or test specimen, then continue the conditioning only until the supporting construction has developed sufficient strength to retain the test specimen securely in position.

10.2 Determine the relative humidity within hardened concrete with a method that uses an electric sensing element. Determine the relative humidity within a supporting construction or test specimen made of materials other than concrete with a method such as one that uses an electric sensing element.

10.3 Do not use wood with a moisture content greater than 13 % as determined by an electrical resistance method.

10.4 When it becomes necessary to use accelerated drying techniques, avoid procedures that will alter the characteristics of the test assembly from those produced as a result of drying in accordance with the procedures specified in 10.1.

10.5 Within 72 h of the fire test, obtain information on the actual moisture content and distribution within the test assembly. When the moisture condition of the test assembly is capable of changing significantly from the 72 h sampling condition prior to test, make the sampling not later than 24 h prior to the test.

11. Movement Cycling Test Procedure

11.1 Require movement cycling if the maximum joint width

does not equal the minimum joint width. Reference 3.1.8 and 3.1.9.

11.2 Prior to the fire exposure, subject test specimens that meet the criteria of 11.1 to movement cycling. Use appropriate cycling apparatus. Reference 6.1.

11.3 The test sponsor selects the movement type desired for the movement cycle test from Table 1.

11.4 Install each test specimen at its nominal joint width. Cycle each test specimen in accordance with the cyclic rate and number of movement cycles for the movement type selected from Table 1.

11.5 Do not allow alterations or modifications which will enhance the thermal performance of the test specimen during or after the movement cycling.

11.6 Examine the test specimen after movement cycling. Note, photograph, and report any indication of stress, deformation or fatigue of the test specimen.

11.7 If a test specimen has been movement cycled separate from its supporting construction, remove it from the cycling apparatus, install it in the supporting assembly, and set it at the maximum joint width prior to fire testing.

NOTE 4—It is recommended that this process take no longer than 96 h.

12. Fire Endurance Test Procedure

12.1 Test Assembly:

12.1.1 Seal the test assembly against the furnace with an insulating gasket between the test assembly and the furnace. Reference 6.2. Tightly seal the open ends of the test specimen against air flow. Throughout the test, periodically check the seals at the ends of the test specimen and repair them, as necessary, to prevent air flow.

12.1.2 Protect the test equipment and test assembly from any condition of wind or weather than influences test results. Measure the ambient air temperature at the beginning of the test; it is not to be less than 50°F (10°C). Measure the velocity of air moving horizontally across the unexposed surface of the test assembly immediately before the test begins; it is not to exceed 4.4 ft/s (1.3 m/s) as determined by an anemometer placed at right angles to the unexposed surface. When mechanical ventilation is employed during the test, do not direct an air stream across the surface of the test assembly.

12.2 Unexposed Surface Temperatures:

12.2.1 Provide unexposed surface thermocouples, reference 6.5, in conformance with the type required by the selected time-temperature curve. Measure the temperatures of the unexposed surface (surface of test assembly opposite the exposure to furnace fire) with thermocouples placed under thermocouple pads, reference 6.6. Immerse the wire leads of the thermocouple under the pad and make them contact the unexposed surface, parallel with the longitudinal direction of the joint, for not less than 1 in. (25 mm). Place the hot junction of the thermocouple approximately under the center of the pad. Firmly hold the pad against the surface and fit it closely about the thermocouple.

12.2.2 When necessary, deform the thermocouple pad to follow the non-planar surface profile of the test specimen. When the maximum joint width is less than the specified pad size, reduce the width of the pad to match the maximum joint

width, subject to a minimum dimension of 0.75 in. (18 mm). The pad length shall be as specified and parallel to the test specimen length. If the modified thermocouple pad cannot be placed on the contour of the surface, then no thermocouple is required at that location.

12.2.3 Do not place unexposed surface thermocouples closer to the furnace edge than 1.5 times the thickness of the supporting construction or 12 in. (305 mm), whichever is greater.

12.2.4 Locate unexposed surface thermocouples on the test assembly as follows:

12.2.4.1 Place one on each splice of each test specimen, at the mid-point of the splice.

12.2.4.2 Place a minimum of one per linear meter along the centerline of the joint, but not less than two per test specimen excluding the splice thermocouple.

12.2.4.3 Place a minimum of one at the junction between each supporting construction and each test specimen.

12.2.4.4 Place a minimum of three per test specimen on the adjacent supporting construction at a maximum distance "T", where T is equal to the maximum thickness of the adjacent supporting construction, from the blackout or joint edge.

12.2.5 When, in the opinion of the laboratory, potential weak spots are identified; attach additional thermocouples to these locations. An example of a weak spot is any irregularity, such as a crack or tear, that has occurred to the test specimen during the cycling or the installation process.

12.2.6 Do not locate thermocouples over fasteners (such as screws, nails or staples) that will be obviously higher or lower in temperature than at a more representative location if the aggregate area of the fasteners on the unexposed surface is less than 1 % of the area within any 6-in. (152-mm) diameter circle, unless the fasteners extend through the test specimen.

12.2.7 For test specimens tested between adjacent walls sections, do not place a thermocouple at an elevation below the neutral pressure plane of the furnace.

12.3 For test specimens that are designed to be load bearing, apply a superimposed load to the test specimen throughout the test. The superimposed load is to simulate the maximum design load for the test specimen. Reference 6.9.

12.4 Simultaneously start the furnace, measuring devices and data acquisition equipment.

12.5 Maintain the fire environment within the furnace in accordance with the standard time-temperature curve shown in the Test Method E 119 or the rapid temperature rise curve shown in Test Method E 1529.

12.6 Furnace Control:

12.6.1 *Test Method E 119 Time-Temperature Curve*—Control the furnace such that the area under the time-temperature curve, obtained by averaging the results from the furnace thermocouple readings, is within 10 % of the corresponding area under the standard time-temperature curve for fire tests of 1 h or less duration, within 7.5 % for those over 1 h and not more than 2 h, and within 5 % for tests exceeding 2 h in duration.

12.6.2 *Test Method E 1529 Time-Temperature Curve*—Control the furnace such that the area under the time-temperature curve of the average of the gas temperature

measurements is within 10 % of the corresponding curve developed in the furnace calibration for tests of ½h or less duration, within 7.5 % of those over ½ h and not more than 1 h, and within 5 % for tests exceeding 1 h.

12.7 Take and record unexposed and furnace temperature readings at intervals not exceeding 1 min throughout the test.

12.8 Furnace Pressure:

12.8.1 Calculate the differential pressure between the exposed and unexposed surfaces of the test assembly based on measurements taken at the specified locations and elevations, and based on the linear pressure gradient of the furnace. Determine the linear pressure gradient of the furnace by the difference in measured pressure of at least two pressure sensors separated by a vertical distance in the furnace.

12.8.2 Operate a horizontal furnace such that a minimum pressure of 0.01 in. H₂O (2.5 Pa) is established at the lowest point of the test specimen.

12.8.3 Operate a vertical furnace such that the 0.01 in. H₂O (2.5 Pa) plane is at or below the mid-height of every test specimen. In the case of a horizontal joint, in a vertical test assembly, subject the entire joint to a minimum pressure of 0.01 in. H₂O (2.5 Pa).

12.8.4 Read and record the differential pressures at intervals not exceeding 1 min throughout the test. Reference 6.7.

12.8.5 After the initial 10 min of fire exposure, control the furnace pressure (at the locations specified) so that it will not be less than 0.01 in. H₂O (2.5 Pa) for the last 25 % of the fire exposure time period and an aggregate time period exceeding:

12.8.5.1 Ten percent of the fire exposure for fire tests of 1 h or less duration,

12.8.5.2 Seven and one-half percent of the fire exposure for fire tests longer than 1 h but not longer than 2 h, and

12.8.5.3 Five percent of the fire exposure for fire tests exceeding 2 h in duration.

12.9 Make observations of the exposed and unexposed surfaces of the test assembly throughout the test. At a maximum of 15 min time intervals, record observations, such as deformation, spalling, cracking, burning, and production of smoke. Measure and record downward or lateral deflection.

12.10 When a crack or hole is observed on the unexposed side of the test specimen during the test, verify the integrity of the test specimen in accordance with Section 13. Record the location, time, and results of each cotton pad application.

12.11 Continue the test until failure occurs or until the test specimen has satisfied all the applicable requirements in 15.2 for the desired fire endurance rating.

12.12 For the purpose of obtaining additional performance data, if desired, continue the test beyond the time that the fire endurance rating is determined.

13. Integrity Test Procedure

13.1 Evaluate the integrity of the test specimen during the fire endurance test for passage of flame and hot gasses using a cotton pad in a wire frame provided with a handle. Reference 6.8.

13.2 Hold the cotton pad directly over an observed crack or hole in the test specimen, approximately 1 in. (25 mm) from the breached surface, for a period of 30 ± 1 s. When required, make small adjustments in the position of the cotton pad to

achieve the maximum effect from the hot gasses.

13.3 When no ignition (defined as glowing or flaming) of the cotton pad occurs during the 30-s application, make “screening tests” that involve short duration applications of the cotton pad to areas of potential failure and/or the movement of a single pad over and around such areas. Charring of the pad only provides an indication of imminent failure. Employ a previously unused cotton pad for an integrity failure to be confirmed.

14. Hose Stream Test Procedure

14.1 Requirements

14.1.1 Within 10 min after the end of the fire endurance test, subject test specimens that are extensions of walls to the impact, erosion, and cooling effects of a hose stream.

14.1.2 Conduct the hose stream test on a duplicate test assembly which has been conditioned, movement cycled, and subjected to a fire test equal to one-half of the fire endurance but not more than 60 min.

14.1.3 As an option and in lieu of the duplicate test assembly in 14.1.2, conduct the hose stream test on the original test assembly after it has completed its full fire endurance.

14.2 Application:

14.2.1 Use the water pressure and duration of application as specified in Table 2 for the hourly fire rating achieved. Reference 6.10.

14.2.2 Locate the nozzle orifice no further than 20 ft (6.1 m) from the center of the exposed surface of the test assembly so that, when directed at the center, its axis is normal to the surface of the test assembly. When the nozzle is unable to be so located, locate it on a line deviating not more than 30° from the line normal to the center of the test assembly. When so located, its distance from the center of the test assembly is to be less than 20 ft (6.1 m) by an amount equal to 1 ± 0.02 ft (305 \pm 6.35 mm) for each 10° of deviation from the normal.

14.2.3 Direct the hose stream first at the bottom and then at all parts of the exposed surface, making changes in direction slowly. Keep the hose stream moving across the test assembly. Do not concentrate, make directional changes, or stop the hose stream on any point on the test assembly. Changes in direction of the hose stream shall be made within 1 ft (310 mm) outside of the perimeter edge of the test assembly. The following is an acceptable pattern.

14.2.3.1 Direct the hose stream around the periphery of the test assembly, starting upward from either bottom corner.

14.2.3.2 After the hose stream has covered the periphery, apply the hose stream in vertical paths approximately 1 ft (310 mm) apart until the entire width has been covered.

14.2.3.3 After the hose stream has covered the width, apply the hose stream in horizontal paths approximately 1 ft (310 mm) apart until the entire height has been covered.

14.2.4 Maintain the hose stream on the test assembly for the duration of application in s/ft^2 (s/m^2) of exposed area as prescribed in Table 2. If the required duration has not been reached and 14.2.3.3 is complete, then repeat 14.2.3 in reverse.

15. Conditions of Compliance

15.1 *Movement Cycling Test*—When movement cycling is conducted, the fire resistive joint system shall have completed at least the minimum number of movement cycles using at least the minimum cyclic rate for the movement type selected.

15.2 *Fire Endurance Test*—Each fire resistive joint system tested shall comply with the following.

15.2.1 The fire endurance rating of the fire resistive joint system shall be determined as the time at whichever of the following conditions occurs first:

15.2.1.1 The temperature rise of any one thermocouple on the unexposed face of the test specimen or adjacent supporting construction is more than 325°F (181°C) above the initial temperature, and

15.2.1.2 For maximum joint widths greater than 4 in. (102 mm), the average temperature rise of the thermocouples on the unexposed face of the test specimen and its supporting construction is more than 250°F (139°C) above the initial temperature.

15.2.2 When the test is continued beyond the rated endurance of the supporting construction, the unexposed thermocouples on the supporting construction in 12.2.4.4 are no longer considered in the conditions of compliance for the test specimen.

15.2.3 When Test Method E 119 is used and the indicated fire endurance rating is 60 min or more, it shall be increased or decreased by the following correction to compensate for significant variation of the measured furnace temperature from the standard time-temperature curve provided that the conditions of 12.6 are met. The correction is expressed by the following formula:

$$C = 2I(A - A_s) / 3(A_s + L) \tag{1}$$

where:

C = correction to the indicated fire endurance in the same units as I,

I = indicated fire endurance in min,

A = area under the actual time-temperature curve for the first three fourths of the indicated fire endurance in °F • min (°C • min),

A_s = the area under the standard time-temperature curve for the first three fourths for the same part of the indicated fire endurance in °F • min (°C • min), and

L = lag correction in the same units as A and A_s, 3240°F • min (1800°C • min), when furnace thermocouples specified in 6.3.1 are used.

15.3 *Integrity Test*— When the cotton pad test is conducted, the fire resistive joint system shall not have allowed the passage of flames or hot gases sufficient to ignite the cotton pad.

15.4 *Load Application*— When a load is applied, the fire

TABLE 2 Water Pressure and Duration of Hose Stream

NOTE 1—The rectangular area of the structure in which the joint system is mounted is to be considered as the exposed area, as the hose stream must traverse this calculated area during application.

Fire Endurance (min) (Hourly Fire Rating)	Water Pressure at Base of Nozzle, psi (kPa)	Duration of Application, s/ft ² (s/m ²) exposed area
240 < 480	45 (310)	3.0 (32)
120 < 240	30 (207)	1.5 (16)
90 < 120	30 (207)	0.9 (10)
< 90	30 (207)	0.6 (6)

resistive joint system shall have sustained the applied load for the full fire resistance period.

15.5 *Hose Stream Test*— When the hose stream test is conducted, the fire resistive joint system shall have withstood the hose stream test without developing any opening that permits a projection of water from the stream beyond the unexposed surface.

15.5.1 A projection of water through a supporting construction within $T/2$, where T is equal to the maximum thickness of the adjacent supporting construction, of the longitudinal edge of the test specimen fails only that test specimen.

15.5.2 A projection of water through a supporting construction between two test specimens outside $T/2$ of the longitudinal edge of either test specimen shall not be deemed a failure of either test specimen.

16. Report

16.1 *General Information*—Include:

16.1.1 The test date and a project number.

16.1.2 As a minimum, the following about the laboratory or test facility:

16.1.2.1 Name and Location.

16.1.2.2 A description of the furnace used and test frame, if any.

16.2 *Test Assembly and Test Specimen Information*— Include a unique designation for each fire resistive joint system tested. When more than one fire resistive joint system is tested, supply separate information for each of the following:

16.2.1 Drawings of the supporting construction and each fire resistive joint system detailing dimensions, materials and composition.

16.2.2 The curing time, if any, for any components of each fire resistive joint system.

16.2.3 The moisture content and the distribution of moisture within the test assembly.

16.2.4 The shape and dimensions of recesses (blockouts) when formed in the supporting construction to secure any part of the fire-resistive joint system.

16.2.5 All installation procedures provided by the test sponsor, details of the equipment used and photographs of the installation procedure.

16.2.6 The splicing method used, including the tests sponsor's instructions and photographic documentation of the installation.

16.2.7 A description of any fire resistive joint system that is tested with a change in direction. Include the test sponsor's installation or fabrication instructions or both, and photographic documentation of the installation.

16.3 *Movement Cycling Test*—When movement cycling is conducted, include the following information:

16.3.1 The nominal joint width.

16.3.2 The maximum joint width.

16.3.3 The minimum joint width.

16.3.4 The movement type selected from Table 1.

16.3.5 The minimum number of cycles completed.

16.3.6 The cyclic rate (cpm) used.

16.3.7 Whether or not the information in 16.3.5 and 16.3.6 satisfies the requirements of 16.3.4. Clearly state whether each fire resistive joint system passed or failed.

16.3.8 Photographs of each fire resistive joint system tested during and after the movement cycling.

16.4 *Fire Endurance Test* —

16.4.1 For each fire-resistive joint system tested, include the following:

16.4.1.1 Length and maximum joint width used in the fire test.

16.4.1.2 The fire endurance rating, expressed in elapsed minutes, for which the relevant performance criteria have been satisfied.

16.4.1.3 The unexposed surface temperatures.

16.4.2 Report the furnace temperatures and the pressure data.

16.4.3 If applied, report the recorded measurement of the superimposed load applied to the fire resistive joint system, method of application, and a photographic documentation of its placement.

16.4.4 Report the recorded measurement of any deflection for each fire resistive joint system and its supporting construction and control method, when applicable.

16.4.5 Report any observations made of the exposed and unexposed surfaces, such as deformation, spalling, cracking, burning, and production of smoke.

16.5 *Integrity Test*— When the integrity test is conducted, report the results for each fire resistive joint system. Clearly state whether each fire resistive joint system passed or failed.

16.6 *Hose Stream Test*— When the hose stream test is conducted, report the performance of each fire resistive joint system. Clearly state whether each fire resistive joint system passed or failed.

17. Precision and Bias

17.1 *Movement Cycling Test*—No information is presented about either the precision and bias of this test method for measuring the response of joint systems to a standard movement cycle test under controlled laboratory conditions because no material having an acceptable reference value has been determined.

17.2 *Fire Endurance Test*—Precision and bias of this test method for measuring the response of joint systems to heat and flame under controlled laboratory conditions are essentially as specified in Test Method E 119 or E 1529.

17.3 *Integrity Test*— No information is presented about either the precision and bias of this test method for measuring the response of joint systems to the integrity test under controlled laboratory conditions since the test is non-quantitative.

17.4 *Hose Stream Test*— No information is presented about either the precision and bias of this test method for measuring the response of joint systems to a standard hose stream under controlled laboratory conditions since the test is non-quantitative.

18. Keywords

18.1 construction gap; cycling; fire; fire endurance; fire-resistance; fire-resistive joint systems; fire separating elements; gaps; hose stream; joint; linear openings; movement; void

APPENDIXES

(Nonmandatory Information)

X1. INTRODUCTION

X1.1 Test Method E 1966 is an American National Standard developed under a full consensus process.

X1.2 The purpose of this Appendix is to aid in understanding why certain testing protocols and conditions of compliance are requirements of Test Method E 1966. There are numerous types of joint systems and applications. No attempt has been made to incorporate all the information available on fire testing

of joint systems in this Appendix.

X1.3 A higher level of fire safety should be expected from joint systems than other building components because a joint system normally passes through multiple compartments. Penetration fire stops, doors, and windows only connect one compartment to another.

X2. PHILOSOPHY AND OTHER TEST METHODS

X2.1 Various test methods and differing philosophies were discussed during the development process of Test Method E 1966.

X2.2 The ASTM Standards discussed included:

X2.2.1 Test Methods E 119 and E 814 because joint systems had been tested by these standards.

X2.2.2 Test Method E 1529 because it is similar to Test Method E 119, except for the more severe time-temperature fire exposure of Test Method E 1529.

X2.2.3 Test Methods E 152⁷ and E 163⁷.

X2.3 There were two major testing philosophies discussed. One was that joint systems are similar to penetration fire stops, doors, and windows and, therefore ought to be tested similar to Test Method E 814. The other was that joint systems are unique building elements similar to floors, walls, columns, beams and other such items and ought to be tested similar to Test Method E 119.

X2.4 Test Method E 1966 incorporates requirements of both Test Method E 119 and E 814 as well as other test requirements that are unique to joint systems.

X2.5 Test Method E 1966 was developed to provide the information needed to judge the anticipated fire performance of fire resistive joint systems because neither Test Methods E 119 or E 814 specifically do so. Section 4.4.4 of Test Method E 119

indicates that it does not provide a simulation of the behavior of joints between building elements because Test Method E 119 does not contain specific criteria for judging them. However, Test Method E 119 Appendix X5.7.4 also specifically references joints and directs evaluation of them concerning structural performance and temperature criteria when they constitute a significant part of the tested assembly.

X2.6 Joint systems were differentiated from penetration fire stops, doors, and windows biased on the information contained in this Appendix and the following:

X2.6.1 Most penetration fire stops, doors, and windows may be tested full scale. Most joint systems can not be tested full scale similar to the building elements tested using Test Method E 119.

X2.6.2 Joints are permanent integral parts of a building; their width, movement capabilities, and location may be structural considerations. In contrast, penetration fire stops, doors, and windows may be added or removed from a building and their openings filled.

X2.6.3 Doors do not require the temperature constraints of Test Method E 119. However according to Test Method E 152, the door's fire endurance should be made equal with the wall when a door is no longer used as a means of egress and combustibles are placed against it.

X2.6.4 Windows tested to Test Method E 163 were not required to withstand prolonged fire exposure as evidenced by the 45-minute fire test and the lack of temperature criteria. However, Test Method E 163 states that the designed fire protection cannot be expected if combustibles are located directly in front of or behind the window opening.

⁷ This standard was withdrawn on January 1, 1995 in accordance with Section 10.5.3.1 of the *Regulations Governing ASTM Technical Committees*, which requires that standards be updated by the end of their eighth year since its last approval date.

X3. APPLICABILITY

X3.1 Architects and specifiers typically specify joint systems by nominal joint width. Test Method E 1966 is intended to be used for, but is not limited to, the following types of joint systems:

X3.1.1 Manufactured from a variety of materials (metallic, elastomeric, ceramic and others),

X3.1.2 Various designs (mechanical, preformed, formed-in-place and others), and

X3.1.3 Wide range of specified nominal joint widths, which typically range from 1 to 48 inches.

X3.2 Test Method E 1966 is intended to be used to evaluate joint systems used in many different applications. These include, but are not limited to the following:

X3.2.1 *Floor-to-floor*— The joint system is abutted by two floor assemblies. This application is normally tested using a horizontal furnace.

X3.2.2 *Wall-to-wall*— The joint system is abutted by two wall assemblies. The joint typically runs vertically and is normally tested using a vertical furnace. However, buildings that use base isolation bearings may also have horizontal joints in walls.

X3.2.3 *Head-of-wall*— The joint system is abutted by a wall assembly below and floor assembly above. The joint typically runs horizontally at the top of the wall and is normally tested using a vertical furnace.

X3.2.4 *Floor-to-wall*— The joint system is abutted by a wall assembly and floor assembly. The joint typically runs horizontally and is normally tested using a horizontal furnace. This application is limited to interior walls only. Reference X3.3 for an explanation.

X3.3 A requirement of Test Method E 1966 is that the joint system is to be exposed to heat and fire from only one side. The testing of a joint system placed into a perimeter joint located between a floor and an exterior wall is not intended to be tested using Test Method E 1966. A very common type of exterior wall used on a multi-story construction is a curtain wall. Testing a joint system installed into a perimeter joint should have heat and flame from below as well as on the exterior face of the exterior wall. This would be a worst-case fire test scenario for a joint system used in a perimeter joint. A test method for such applications is currently under development by an ASTM E05 Task Group.

X4. FURNACE TEMPERATURES

X4.1 Fire resistive joint systems are predominantly used in buildings and other types of building construction in which their fire endurance is measured using Test Method E 119. Other industries employ joint systems designed to resist more

intense fires, which may occur in petroleum related operations. Test Method E 1966 also allows the Test Method E 1529 time-temperature curve to be used to evaluate such applications.

X5. FURNACE PRESSURE

X5.1 It is a requirement of Test Method E 1966 that joint systems be subjected to positive furnace pressure. Positive furnace pressure is normally a more severe condition than negative furnace pressure for fire testing joint systems. Negative furnace pressure may allow cooler air to be drawn into or through the entire joint system from the unexposed face of the test assembly. Cooler air may increase the fire endurance rating of the joint system. Test Method E 1966 requires that a minimum positive pressure of 0.01 inches of H₂O be established in the furnace at the following locations:

- the lowest point of the test specimen in a horizontal furnace,
- at or below the mid-height of vertical test specimen in a vertical furnace, and
- for the entire horizontal test specimen in a vertical furnace.

X5.2 The model building codes require positive pressure testing of joint systems. Test Method E 814 also requires positive pressure testing.

X6. CYCLING

X6.1 It is a requirement of Test Method E 1966 that dynamic joint systems are to be cycled. Movement cycling before fire testing is usually a more severe condition than not cycling. Cycling is intended to induce movement that might fatigue a joint system and may affect its fire endurance rating. The fire endurance rating of a joint system that moves is established after movement cycling.

X6.2 Cycling verifies the minimum and maximum joint widths established by the test sponsor.

X6.3 Movement cycling is not intended to simulate all the performance characteristics or replicate in situ performance of a joint system.

X6.4 Most joint systems flex or slide to accommodate

movement. Movement cycling tests the ability of materials from which joint systems are made to cycle. In contrast, other building components such as doors and windows are not subjected to movement cycling before fire testing because doors typically use hinges and windows use tracks that do not fatigue the material from which a door or window is made.

X6.5 Cycling joint systems decreases a fire safety concern with joint systems that may be hidden from view (e.g. by carpeting) and not easily inspected to detect possible fatigue.

X6.6 Cycling joint systems may also demonstrate the compatibility of the joint system with the adjoining construction.

X7. SUPPORTING CONSTRUCTION

X7.1 Test Method E 1966 is intended to evaluate the possible effects that joint systems will have upon building construction. Test Method E 1966 is not intended to evaluate building construction, which is normally tested to Test Method E 119. The supporting construction is required to have a known fire endurance rating. Based on test experience and work on

lateral heat transfer, only the distance “T” needs to be monitored. (The distance “T” is equal to the thickness of the supporting construction measured from the joint edge.) The effect of a joint system on the rated supported construction is part of Test Method E 1966.

X8. MULTIPLE TEST SPECIMENS

X8.1 It is allowable to simultaneously test multiple joint systems at the option of the test sponsor. Electing this option does not waive any of the conditions of compliance. Normally, adding additional test specimens introduces a degree of conservatism because one joint may negatively affect the perfor-

mance of other joints.

X8.2 Test Method E 814 also permits multiple test specimens to be evaluated simultaneously.

X9. SPLICES

X9.1 It is a requirement of Test Method E 1966 that splices be tested. Splices made in the joint system are positioned in the positive pressure area of the test furnace during the fire test. Joint systems may have manufactured splices, or field splices, or both. A splice may be a weak point in the joint system because it is a disruption of a continuous piece of material or

the installation process. Factory and field splices are terms referenced in Section 7. The factory splice is performed at the point of manufacture and a field splice is performed during the installation process. Formed-in-place field splices are also tested because the application may be started and stopped resulting in differential curing.

X10. TEST SPECIMEN LENGTH

X10.1 The minimum exposed test specimen length is based upon the maximum joint width.

X10.1.1 The minimum test specimen lengths used for maximum joint widths greater than 4 inches are based on Test Method E 119. An exposed length of 9 feet for vertical furnace test specimens and 12 feet for horizontal furnace test specimens is required.

X10.1.2 A joint system tested at a maximum joint width less than or equal to 4 inches requires a minimum exposed length

of 48 inches for tests conducted using either vertical or horizontal furnaces. A joint system requires a minimum distance of approximately two feet to place all the thermocouples in compliance with Test Method E 1966. The exposed length must also include at least 12-inches at each end so that the thermocouple data will not be affected by furnace edge conditions.

X11. TESTED JOINT WIDTH

X11.1 A requirement of Test Method E 1966 is that joint systems be tested at their maximum joint width. To accomplish this, joint systems are normally installed at the nominal joint width and then opened to their maximum joint width before fire testing. Fire testing a joint system at its maximum joint width is more severe than fire testing the same joint system at either the nominal joint width or minimum joint width.

X11.2 A mass of materials joint system) is installed into the joint to protect it. The installation of these materials takes place at the nominal joint width. The ratio of the mass of these materials to the volume of the joint becomes increasingly smaller as the joint opens. The smallest ratio occurs at the maximum joint width. When the joint is fully open, the same

amount of material that was installed into the nominal joint width is now protecting the maximum joint width.

X11.3 The joint width during an actual fire is an unknown factor. Joint systems are not normally fully open during an actual fire. Testing at the maximum joint width is the most conservative approach to fire safety because it can account for some joint system expansion that may occur during an actual fire caused by differential deflection of the supporting construction.

X11.4 The maximum joint width may also create a tensile stress on the bond line of formed-in-place or preformed sealants, which may be a critical factor in the fire endurance testing of these types of joint systems.

X12. UNEXPOSED THERMOCOUPLE PADS

X12.1 Test Method E 1966 uses the 6 x 6-inch pads of Test Method E 119 for maximum joint widths equal to or greater than 6 inches.

X12.2 Responsive to a concern about reproducibility of results when the pad size is greater than the maximum joint width, a requirement is that the 2 x 2-inch pads of Test Method E 814 are to be used when the maximum joint width is less than 6 inches. This requirement now limits concern about reproducibility of results to maximum joint widths less than 2 inches.

X12.3 Using 6 x 6-inch pads usually results in a reduction of the fire endurance rating, when simultaneously testing 2 x 2-inch and 6 x 6-inch pads and comparing the results. The use of 6 x 6-inch pads was based partly on the following fire safety concerns:

X12.3.1 Joint systems are routinely in contact with combustibles, such as carpet or wall coverings. This mainly occurs for aesthetic reasons.

X12.3.2 The widths of joint systems vary greatly, commonly 1 to 48 inches in nominal joint width. A failed joint system may be an obstacle to the means of egress during a fire.

When a joint system fails it may reveal the large linear void, which was covered and protected.

X12.3.3 A joint system may occupy the majority of floor area in a corridor or small room.

X12.3.4 Current building codes do not regulate the location of joint systems or prohibit combustibles from being in contact with them.

X12.4 The size of the thermocouple pads may influence the fire endurance rating.⁸ Fire tests have revealed lower temperatures being recorded with 2 x 2-inch pads than with 6 x 6-inch pads, when simultaneously tested.

X12.5 A requirement of Test Method E 1966 is that a minimum of five unexposed thermocouples on the joint system is used to establish a relative measure of the joint system's fire endurance. A minimum of three unexposed thermocouples on the supporting construction is a requirement to monitor the possible effects of the joint system on the supporting construction. Laboratories have the option of placing additional thermocouples to provide a broader fire performance profile.

⁸ Nicholas, J.D., "Fire Resistive Joints - A History in the Making" *Fire Standards in the International Marketplace*, ASTM, STP 1163, ASTM 1995, pp. 100-112.

X13. DEFLECTION AND LOAD

X13.1 Measuring and reporting the amount and type of deflection of the joint system during the fire test may be useful information.

X13.1.1 Two types of deflection may be possible during a fire test of joint systems: uniform and differential. Uniform deflection occurs when both supporting constructions deflect simultaneously at the same rate. Differential deflection occurs when one supporting construction deflects at a different rate than the other e.g., when a floor assembly abuts a wall assembly. Differential deflection is usually more severe than uniform deflection because it may place additional stresses on the joint system.

X13.1.2 Deflection is dependent on numerous factors such as restraining or not restraining the supporting construction, the span, the supporting construction thickness, the materials,

loads placed upon the supporting construction, the fire exposure duration and intensity. Test Method E 1966 requirements do not restrict any of these variables. Therefore, the deflection values of one joint system should only be compared to another when using identical supporting construction, the same measuring technique, and test parameters.

X13.2 A requirement of Test Method E 1966 is that joint systems that are designed to be load bearing are to be tested under their maximum design load throughout the fire test. Load bearing joint systems may be a greater fire safety concern because they are commonly found in the means of egress (such as exit corridors) of hospitals, airports, office buildings and the like.

X14. HOSE STREAM TEST

X14.1 A requirement of Test Method E 1966 is that a hose stream test be conducted. This requirement applies to both vertical and horizontal joint systems tested on the vertical furnace. The hose stream test subjects the joint system to the impact, cooling, and erosion effects of a stream of water.

X14.2 The effect of the joint system on the supporting construction is also a Test Method E 1966 consideration. However, the area on the supporting construction being monitored is limited. This area is defined as “T/2” wide times the test specimen length. This area is located adjacent to and

parallel with each side of the joint. Any breach of this area is a failure, regardless of its point of origin. Many other factors may influence the fire performance of supporting construction and are not the concern of a joint system test.

X14.3 It is permitted to continue the fire test beyond the rated fire endurance period of the supporting construction. This choice may weaken the supporting construction but does not exempt the joint system from the application of the hose stream and the Conditions of Compliance.

X15. UNEXPOSED SURFACE TEMPERATURES

X15.1 A conservative fire safety approach to the Test Method E 1966 conditions of compliance was taken. Both the average and single point unexposed surface temperature criteria of Test Method E 119 were adopted. In addition to the other information in this Appendix, the rationale for adopting a 250°F average and a 325°F single point above the initial temperatures is as follows:

X15.1.1 Test Method E 119 assemblies and joint systems are integral parts of a building. Joints are normally created to fulfill structural concerns that dictate their location, movement capabilities and nominal joint width.

X15.1.2 Joint systems are sometimes incorrectly referred to as linear fire stops. E 814 created the “F rating” acceptance criteria because penetration fire stops are not normally in contact with combustibles. The E 814 “T rating” of 325°F single point failure was a compromise to those supporting the Test Method E 119 conditions of acceptance criteria. Unlike fire stops, combustibles (such as carpeting and wall coverings) may cover joint systems.

X15.2 Test Method E 1966 is a test of the joint system but is not a test of the supporting construction. The supporting construction should be fire endurance rated by Test Method E 119. When a joint system has not reached any of the limitations in the conditions of compliance but the supporting construction has done so, a provision in Test Method E 1966 provides the sponsor the option to continue the fire test. When the sponsor elects this option, an exception is made to the conditions of compliance. When the fire endurance rating period of the supporting construction is reached, the unexposed thermocouples in 12.2.4 may be omitted from the average or single point failure criteria. However, all other conditions of compliance still must be met. The unexposed thermocouples in 12.2.4 may eventually exceed the temperature limitations set forth in the conditions of compliance because the fire test is being extended beyond the known fire endurance rating of the supporting construction.

X16. EXTENSION OF DATA

X16.1 The time-temperature fire exposure in Test Method E 1529 is more severe than in Test Method E 119. A joint system tested under Test Method E 1966 protocols using the Test Method E 1529 time-temperature curve, therefore, should have a fire endurance rating that is the same as or better than that of the identical joint system tested in identical test assembly to the Test Method E 119 time-temperature curve.

X16.2 Test Method E 1399 was the basis for Section 11 in Test Method E 1966. The formulas in Test Method E 1399 may be used to calculate and express the movement of the joint system in terms of percent of the nominal joint width.

X16.3 A 48-inch tall vertical test specimen designed with linear air pocket may have a greater fire endurance rating than the 9-foot tall one of the same design and maximum joint width. The location of the neutral pressure plane in a 48-inch

test specimen would be located 24 inches from the base of the test assembly generating approximately 0.02 inches of H₂O at its top. The 9-foot test specimen will have its neutral plane 4.5 feet from the base and generate an approximate positive pressure of 0.045 inches of H₂O at its top. The difference in performance may be attributed to the amount of hot air inside the joint system pooling at the top.

X16.4 The fire endurance of different joint systems is normally compared and evaluated using the same maximum joint width. One can not test every conceivable design at every maximum joint width for every application. A Task Group in Committee E05 is working on a standard that may be used to interpolate and extrapolate data. Therefore, no information is offered on this topic; other than, laboratories and consultants having experience with fire testing joint systems routinely offer engineering analysis.

The American Society for Testing and Materials takes no position respecting the validity of any patent rights asserted in connection with any item mentioned in this standard. Users of this standard are expressly advised that determination of the validity of any such patent rights, and the risk of infringement of such rights, are entirely their own responsibility.

This standard is subject to revision at any time by the responsible technical committee and must be reviewed every five years and if not revised, either reapproved or withdrawn. Your comments are invited either for revision of this standard or for additional standards and should be addressed to ASTM Headquarters. Your comments will receive careful consideration at a meeting of the responsible technical committee, which you may attend. If you feel that your comments have not received a fair hearing you should make your views known to the ASTM Committee on Standards, at the address shown below.

This standard is copyrighted by ASTM, 100 Barr Harbor Drive, PO Box C700, West Conshohocken, PA 19428-2959, United States. Individual reprints (single or multiple copies) of this standard may be obtained by contacting ASTM at the above address or at 610-832-9585 (phone), 610-832-9555 (fax), or service@astm.org (e-mail); or through the ASTM website (www.astm.org).