



Standard Test Methods for Measurement of Synthetic Polymer Material Flammability Using a Fire Propagation Apparatus (FPA)¹

This standard is issued under the fixed designation E 2058; the number immediately following the designation indicates the year of original adoption or, in the case of revision, the year of last revision. A number in parentheses indicates the year of last reapproval. A superscript epsilon (ϵ) indicates an editorial change since the last revision or reapproval.

1. Scope

1.1 This fire-test-response standard determines and quantifies synthetic polymer material flammability characteristics, related to the propensity of materials to support fire propagation, by means of a fire propagation apparatus (FPA). Material flammability characteristics that are quantified include time to ignition (t_{ign}), chemical (\dot{Q}_{chem}), and convective (\dot{Q}_c) heat release rates, mass loss rate (\dot{m}) and effective heat of combustion (EHC).

1.2 The following test methods, capable of being performed separately and independently, are included herein:

1.2.1 *Ignition Test*, to determine t_{ign} for a horizontal specimen;

1.2.2 *Combustion Test*, to determine \dot{Q}_{chem} , \dot{Q}_c , \dot{m} , and EHC from burning of a horizontal specimen; and,

1.2.3 *Fire Propagation Test*, to determine \dot{Q}_{chem} from burning of a vertical specimen.

1.3 Distinguishing features of the FPA include tungsten-quartz external, isolated heaters to provide a radiant flux of up to 65 kW/m² to the test specimen, which remains constant whether the surface regresses or expands; provision for combustion or upward fire propagation in prescribed flows of normal air, air enriched with up to 40 % oxygen, air oxygen vitiated, pure nitrogen or mixtures of gaseous suppression agents with the preceding air mixtures; and, the capability of measuring heat release rates and exhaust product flows generated during upward fire propagation on a vertical test specimen 0.305 m high.

1.4 The FPA is used to evaluate the flammability of synthetic polymer materials and products. It is also designed to obtain the transient response of such materials and products to prescribed heat fluxes in specified inert or oxidizing environments and to obtain laboratory measurements of generation rates of fire products (CO₂, CO, and, if desired, gaseous hydrocarbons) for use in fire safety engineering.

1.5 Ignition of the specimen is by means of a pilot flame at a prescribed location with respect to the specimen surface.

1.6 The Fire Propagation test of vertical specimens is not

suitable for materials that, on heating, melt sufficiently to form a liquid pool.

1.7 Values stated are in SI units. Values in parentheses are for information only.

1.8 This standard is used to measure and describe the response of materials, products, or assemblies to heat and flame under controlled conditions, but does not by itself incorporate all factors required for fire hazard or fire risk assessment of the materials, products or assemblies under actual fire conditions.

1.9 *This standard does not purport to address all of the safety concerns, if any, associated with its use. It is the responsibility of the user of this standard to establish appropriate safety and health practices and determine the applicability of regulatory limitations prior to use.* For specific hazard statements, see Section 7.

2. Referenced Documents

2.1 ASTM Standards:

E 176 Terminology of Fire Standards²

E 906 Test Method for Heat and Visible Smoke Release Rates for Materials and Products²

E 1321 Test Method for Determining Material Ignition and Flame Spread Properties²

E 1354 Test Method for Heat and Visible Smoke Release Rates for Materials and Products Using an Oxygen Consumption Calorimeter²

E 1623 Test Method for Determination of Fire and Thermal Parameters of Materials, Products, and Systems Using an Intermediate Scale Calorimeter (ICAL)²

3. Terminology

3.1 *Definitions*—For definitions of terms used in these test methods, refer to Terminology E 176.

3.2 Definitions of Terms Specific to This Standard:

3.2.1 *effective heat of combustion, EHC, (kJ/kg), n*—the energy generated by chemical reactions per unit mass of fuel vaporized.

3.3 Symbols:

A_d = cross sectional area of test section duct (m²)

¹ These test methods are under the jurisdiction of ASTM Committee E-05 on Fire Standards and are the direct responsibility of Subcommittee E05.22 on Surface Burning.

Current edition approved Jan. 10, 2000. Published April 2000.

² Annual Book of ASTM Standards, Vol 04.07.

c_p	= specific heat of air at constant pressure (kJ/kg K)
\dot{G}_{co}	= mass flow rate of CO in test section duct (kg/s)
\dot{G}_{co_2}	= mass flow rate of CO ₂ in test section duct (kg/s)
ΔH_{eff}	= effective heat of combustion (kJ/kg)
K	= flow coefficient of averaging Pitot tube [duct gas velocity/(2 $\Delta p_m/\rho$) ^{1/2}] (-)
M_{loss}	= ultimate change in specimen mass resulting from combustion (kg)
\dot{m}	= mass loss rate of test specimen (kg/s)
\dot{m}_d	= mass flow rate of gaseous mixture in test section duct (kg/s)
P_{atm}	= atmospheric pressure (Pa)
Δp_m	= pressure differential across averaging Pitot tube in test section duct (Pa)
Q	= cumulative heat released during Combustion Test (kJ)
\dot{Q}_{chem}	= chemical heat release rate (kW)
\dot{Q}_c	= convective heat release rate (kW)
T_a	= gas temperature in test section duct before ignition (K)
T_d	= gas temperature in test section duct (K)
t	= time (s)
t_{ign}	= ignition time (s)
Δt	= time between data scans (s)
X_{CO_2}	= measured carbon dioxide analyzer reading or mole fraction of carbon dioxide (-)
X_{CO}	= measured carbon monoxide analyzer reading or mole fraction of CO (-)

3.4 Superscripts:

- \cdot = per unit time (s⁻¹)
- o = before ignition of the specimen

3.5 Subscripts:

- $_d$ = test section duct
- $_j$ = fire product

4. Summary of Test Method

4.1 Three separate test methods are composed herein, and are used independently in conjunction with a Fire Propagation Apparatus. The Ignition and Combustion test methods involve the use of horizontal specimens subjected to a controlled, external radiant heat flux, which can be set from 0 up to 65 kW/m². The Fire Propagation test method involves the use of vertical specimens subjected to ignition near the base of the specimen from an external radiant heat flux and a pilot flame. Both the Combustion and Fire Propagation test methods can be performed using an inlet air supply that is either normal air or other gaseous mixtures, such as air with added nitrogen or air enriched with up to 40 % oxygen.

4.2 The Ignition test method is used to determine the time required for ignition, t_{ign} , of horizontal specimens by a pilot flame as a function of the magnitude of a constant, externally applied radiant heat flux. Measurements also are made of time required until initial fuel vaporization. The surface of these specimens is coated with a thin layer of black paint to ensure complete absorption of the radiant heat flux from the infrared heating system (note that the coating does not itself undergo sustained flaming).

4.3 The Combustion test method is used to determine the chemical and convective heat release rates when the horizontal test specimen is exposed to an external radiant heat flux.

4.4 The Fire Propagation test method is used to determine the chemical heat release rate of a burning, vertical specimen during upward fire propagation and burning initiated by a heat flux near the base of the specimen. Chemical heat release rate is derived from the release rates of carbon dioxide and carbon monoxide. Observations also are made of the flame height on the vertical specimen during fire propagation.

5. Significance and Use

5.1 These test methods are an integral part of existing test standards for cable fire propagation and clean room material flammability, as well as, in an approval standard for conveyor belting (1-3).³ Refs (1-3) use these test methods because fire-test-response results obtained from the test methods correlate with fire behavior during real-scale fire propagation tests, as discussed in X1.4

5.2 The Ignition, Combustion, or Fire Propagation test method, or a combination thereof, have been performed with materials and products containing a wide range of polymer compositions and structures, as described in X1.7.

5.3 The Fire Propagation test method is different from the test methods in the ASTM standards listed in 2.1 by virtue of producing laboratory measurements of the chemical heat release rate during upward fire propagation and burning on a vertical test specimen in normal air, oxygen-enriched air, or in oxygen-vitiated air. Test methods from other standards, for example, Test Method E 1321, which yields measurements during lateral/horizontal or downward flame spread on materials and Test Methods E 906, E 1354, and E 1623, which yield measurements of the rate of heat release from materials fully involved in flaming combustion, generally use an external radiant flux, rather than the flames from the burning material itself, to characterize fire behavior.

5.4 These test methods are not intended to be routine quality control tests. They are intended for evaluation of specific flammability characteristics of materials. Materials to be analyzed consist of specimens from an end-use product or the various components used in the end-use product. Results from the laboratory procedures provide input to fire propagation and fire growth models, risk analysis studies, building and product designs, and materials research and development.

6. Apparatus

6.1 General:

6.1.1 Where dimensions are stated in the text or in figures, they shall be considered mandatory and shall be followed within a nominal tolerance of $\pm 0.5\%$. An exception is the case of components meant to fit together, where the joint tolerance shall be appropriate for a sliding fit.

6.1.2 The apparatus (see overview in Fig. 1 and exploded views in Figs. 2 and 3) shall consist of the following components: an infrared heating system, a load cell system, an

³ The boldface numbers in parentheses refer to the list of references at the end of this standard.

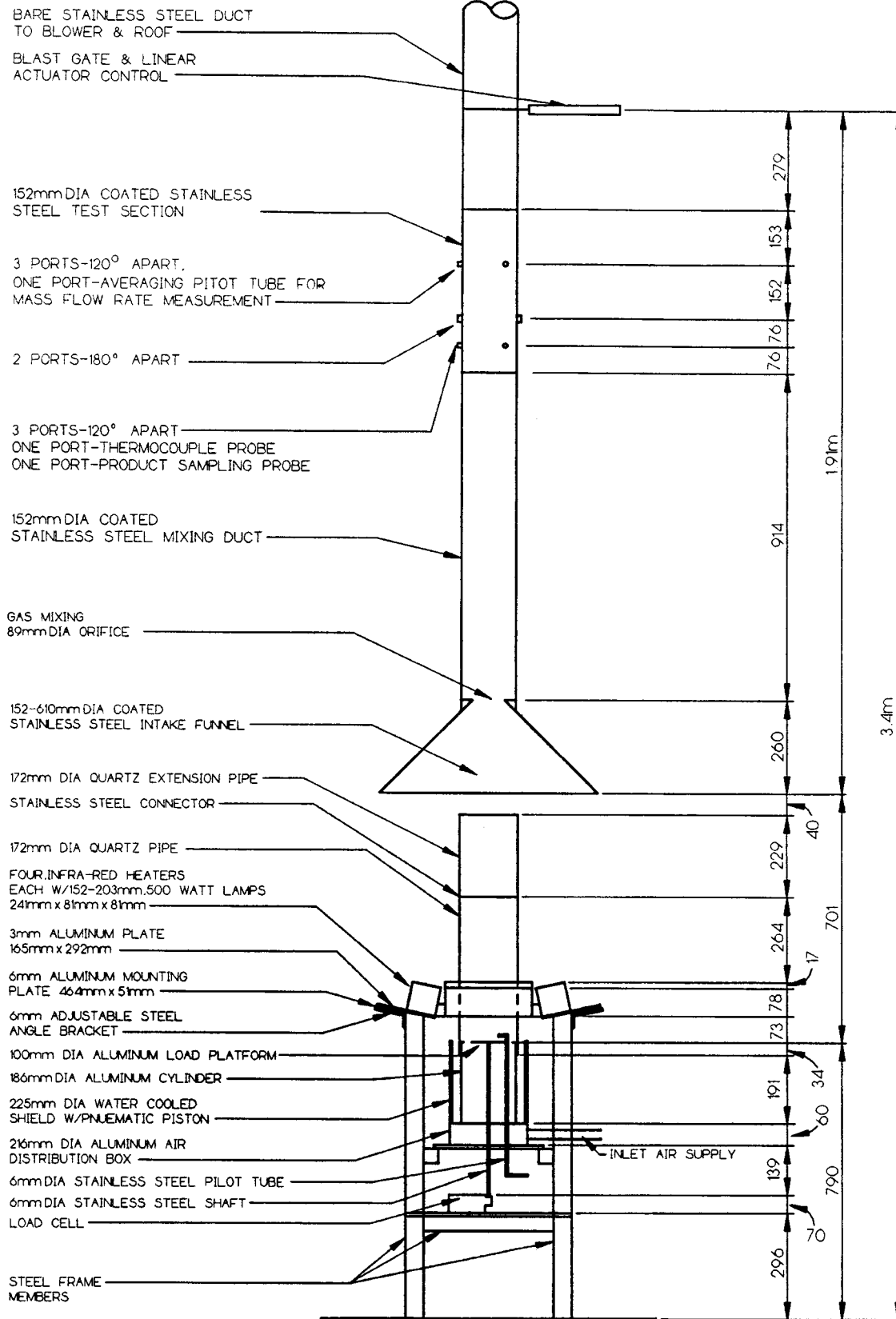

MAIN VIEW

ALL DIMENSIONS ARE mm UNLESS NOTED

FIG. 1 Main View

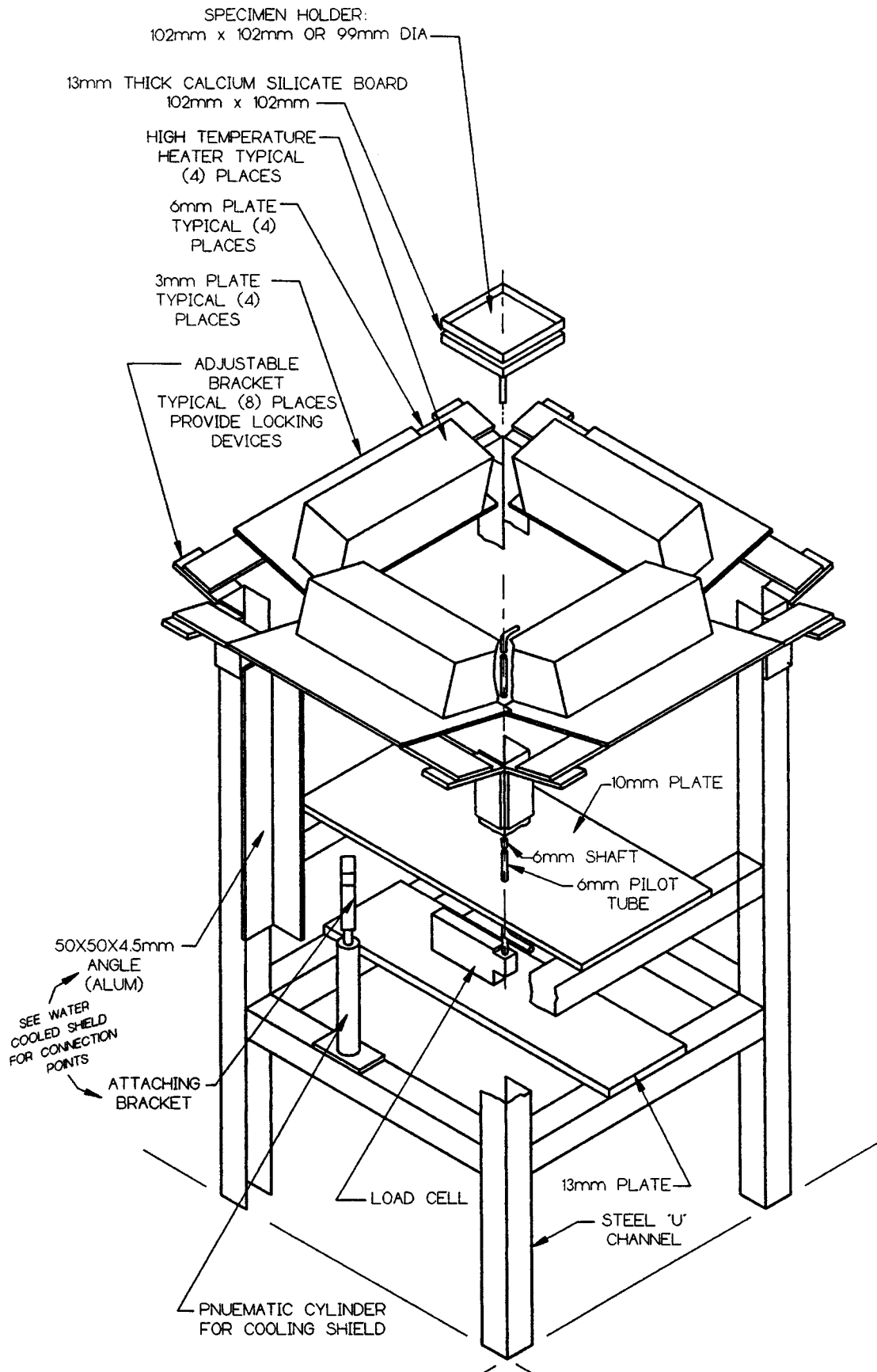
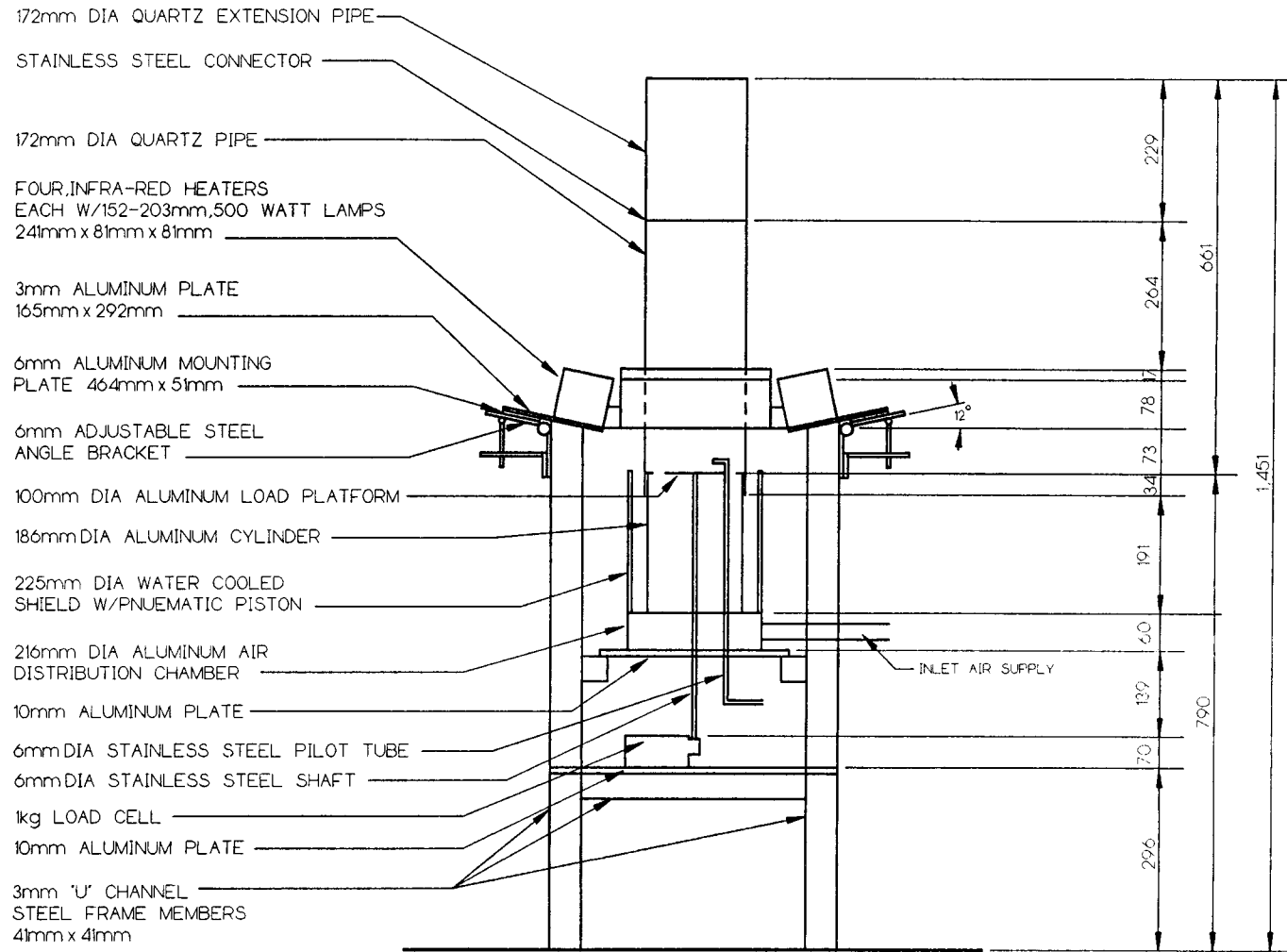

FIG. 2 Exploded View of Specimen Mounting



NOTE 1—All dimensions are in mm unless noted.

FIG. 3 Exploded Main View

ignition pilot flame and timer, a product gas analysis system, a combustion air distribution system, a water-cooled shield, an exhaust system, test section instruments, calibration instruments, and a digital data acquisition system.

6.2 *Infrared (IR) Heating System*—The IR Heating System⁴ shall consist of four 241-mm long heaters (see different views in Figs. 1-3) and a power controller.

6.2.1 *IR Heaters*—Each of four IR heaters shall contain six tungsten filament tubular quartz lamps in a compact reflector body that produces up to 510 kW/m² of radiant flux in front of the quartz window that covers the lamps. The reflector body is water cooled and the lamp chamber, between the quartz window and reflector, is air cooled for prolonged life. The emitter of each lamp is a 127-mm long tungsten filament in an argon atmosphere enclosed in a 9.5-mm outer diameter clear quartz tube. The emitter operates at approximately 2205°C (4000°F) at rated voltage, with a spectral energy peak at 1.15 micron. Wavelengths greater than about 2-microns are absorbed by the quartz bulb envelope and heater front window, which are air cooled.

6.2.2 *Power Controller*—The controller shall maintain the output voltage required by the heater array despite variations in load impedance through the use of phase angle power control to match the hot/cold resistance characteristics of the tungsten/quartz lamps. The controller also shall incorporate average voltage feedback to linearize the relationship between the voltage set by the operator and the output voltage to the lamps.

6.3 *Load Cell System*—The load cell system, shown in Figs. 1-3, shall consist of a load cell, which shall have an accuracy of 0.1 g, and a measuring range of 0–1000 g; a 6.35-mm diameter stainless steel shaft, at least 330 mm long, resting on the load cell support point; a 100-mm diameter, 1.5-mm thick aluminum load platform connected to the upper end of the stainless steel shaft by a collar; and two low friction, ball-bushing bearings that guide the shaft as it passes through the top and bottom, respectively, of the air distribution chamber. The stainless steel shaft shall incorporate, at the lower end, a threaded adjustment rod to compensate for horizontal test specimens of different thicknesses.

6.4 *Ignition Pilot Flame*—The ignition pilot shall consist of an ethylene/air (60/40 by volume) flame adjusted for a 10-mm length. The pilot flame is anchored at the 50-mm long, horizontal end of a 6.35-mm O.D., 4.70-mm I.D. stainless steel tube. In the horizontal tube section, use a four-hole ceramic insert to produce a stable flame and prevent flashback. The pilot flame tube shall be able to be rotated and elevated to position the horizontal flame at specified locations near the specimen, as shown in Figs. 2 and 3.

6.5 *Ignition Timer*—The device for measuring time to sustained flaming shall be capable of recording elapsed time to the nearest tenth of 1 s and have an accuracy of better than 1 s in 1 h.

6.6 *Gas Analysis System*—The gas analysis system shall consist of a gas sampling system and gas analysis instruments, described in 6.6.1-6.6.4

6.6.1 *Gas Sampling*—The gas sampling arrangement is shown in Fig. 4. This arrangement consists of a sampling probe in the test section duct, a plastic filter (5-micron pore size) to prevent entry of soot, a condenser operating at temperatures in the range –5°C to 0°C to remove liquids, a tube containing an indicating desiccant (10–20 mesh) to remove most of the remaining moisture, a filter to prevent soot from entering the analyzers, if not already removed, a sampling pump that transports the flow through the sampling line, a system flow meter, and manifolds to direct the flow to individual analyzers (CO, CO₂, O₂, and hydrocarbon gas). The sampling probe, made of 6.35-mm (0.25-in.) O.D. stainless steel tubing inserted through a test section port, shall be positioned such that the open end of the tube is at the center of the test section. The sampling probe is connected to a tee fitting that allows either sample or calibration gas to flow to the analyzer, and the excess to waste.

6.6.2 *Carbon Dioxide/Carbon Monoxide Analyzers*—The carbon dioxide analyzer shall permit measurements from 0 to 15 000 ppm and the carbon monoxide analyzer shall permit measurements from 0 to 500 ppm concentration levels. Drift shall be not more than ± 1 % of full scale over a 24-h period. Precision shall be 1 % of full-scale and the 10 to 90 % of full-scale response time shall be 1 s or less.

6.6.3 *Inlet-Air Oxygen Analyzer*—This analyzer shall have a 10 to 90 % of full-scale response time of 1 s or less, an accuracy of 1 % of full-scale, a drift of not more than ± 50 ppm O₂ over ½ h and a 0 to 50 % range.

6.6.4 *Optional Product Analyzers for the Combustion Test*—An additional oxygen analyzer can be used to measure the depletion of oxygen in the combustion products. This analyzer should have the same specifications as the inlet-air analyzer but should have a concentration range of 19 to 21 %. A hydrocarbon gas analyzer employing the flame ionization method of detection can be used to determine the total gaseous hydrocarbon concentration. This analyzer should have a 10 to 90 % of full-scale response time of 1 s or less and multiple ranges to permit measurements from a full-scale of 10 ppm methane equivalent to 10 000 ppm.

6.7 *Combustion Air Distribution System*—This system shall consist of an air distribution chamber, shown in Fig. 5, and air supply pipes, shown in Figs. 6 and 7.

6.7.1 *Air Distribution Chamber*—This aluminum chamber, shown in Fig. 5, shall contain eight discharge tubes arranged in a circle of 165-mm inside diameter. Each tube shall be aluminum and built to distribute inlet gases (air, O₂, N₂, etc.) to three sets of screens (stainless steel woven wire cloth of 10, 20, and 30 mesh from bottom to top, respectively), for producing a uniform air flow. Inlet air flows downward through the eight discharge tubes, disperses on the bottom plate, then rises through the mesh screens toward the aluminum support cylinder.

6.7.2 *Air Supply Pipes*—These pipes shall consist of an aluminum cylinder, shown in Figs. 3 and 6 extending from the air distribution chamber up to the load platform. This cylinder shall contain a step (see Figs. 6 and 7) to support a quartz pipe. Above the load platform elevation, the quartz pipe (see Figs. 6 and 7) shall supply oxidant to the specimen flame while

⁴ The Model 5208-05 high density infrared heater with Model 500T3/CL/HT lamps and Model 664 SCR power controller, manufactured by Research, Inc., P.O. Box 24064, Minneapolis, MN 55424 is suitable for this purpose.

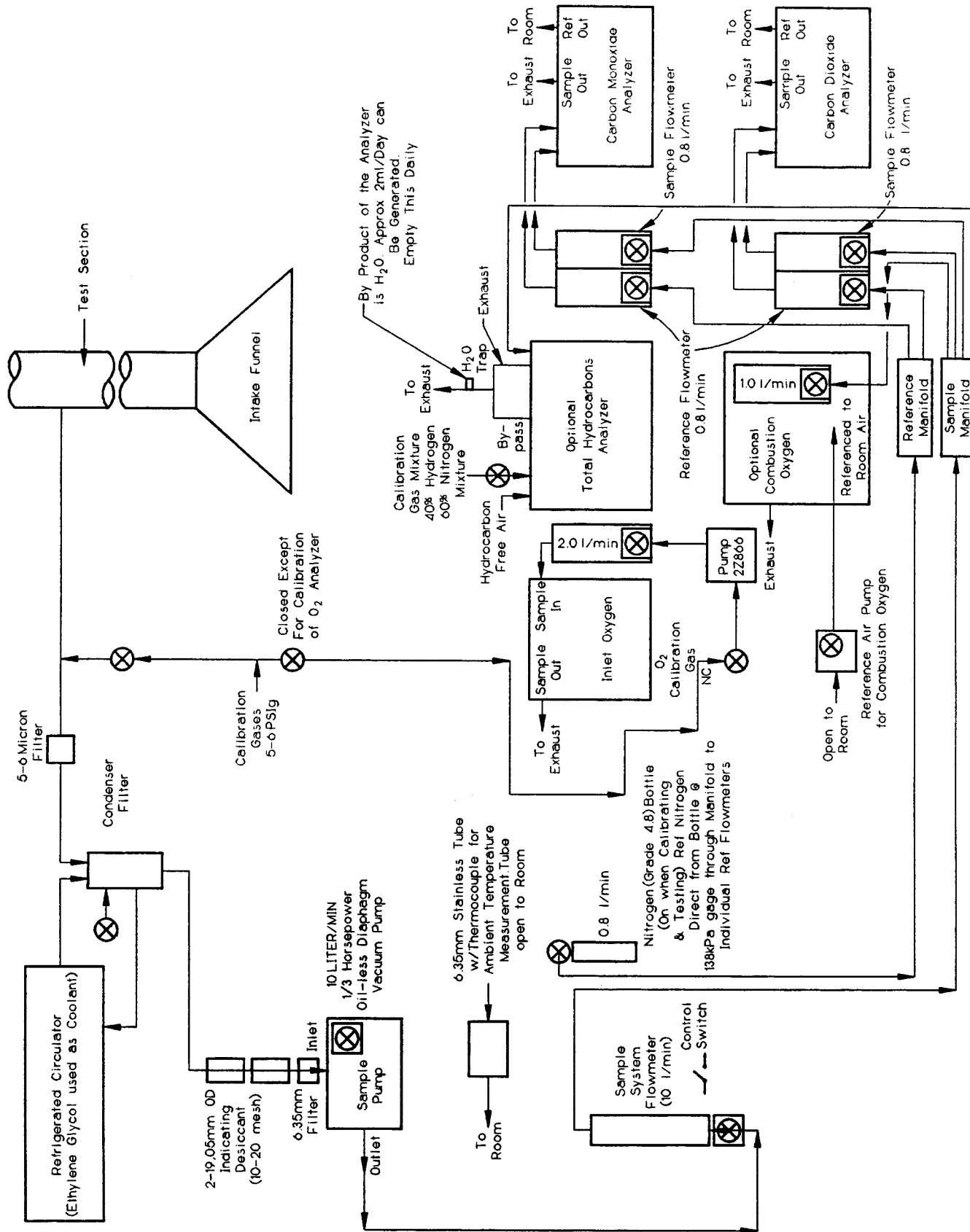

FIG. 4 Flow Diagram of Gas Sampling System

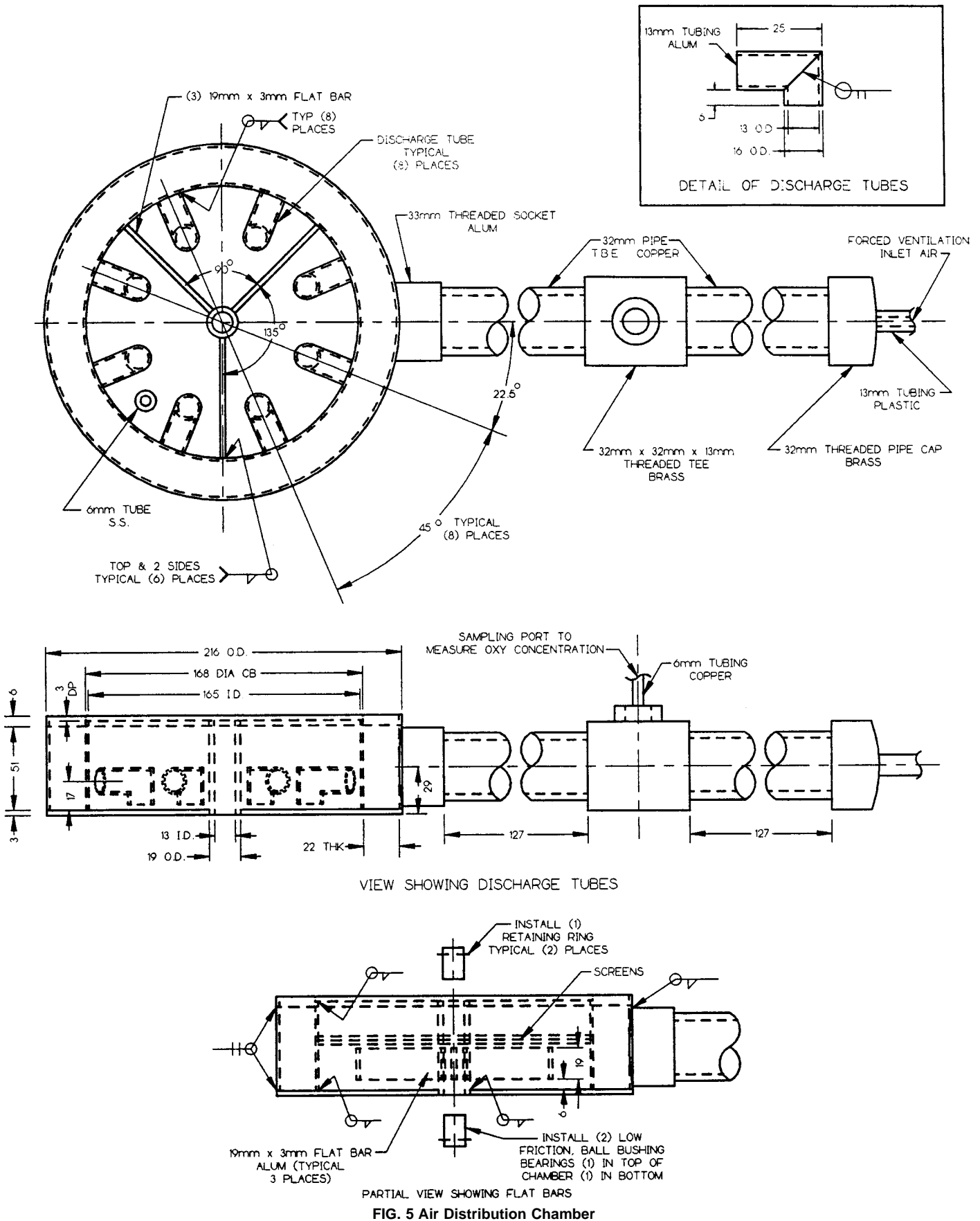

FIG. 5 Air Distribution Chamber

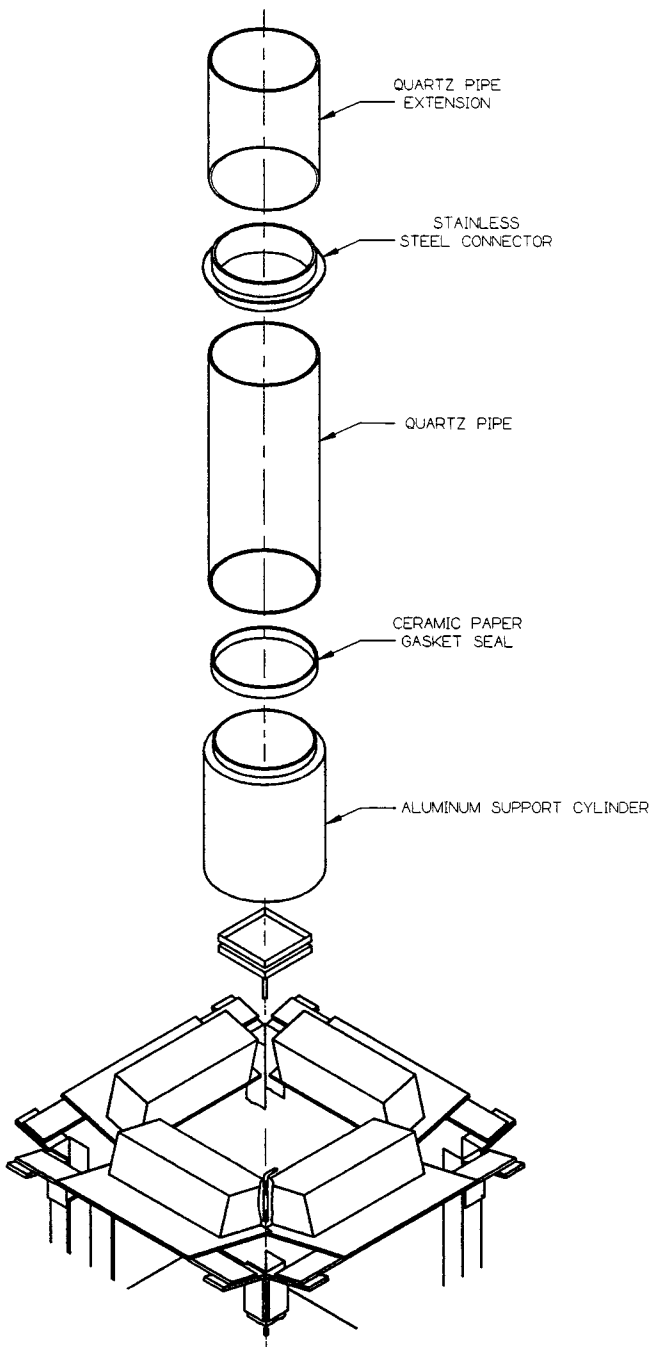

FIG. 6 Exploded View of Quartz Pipe Assembly

allowing radiant energy from the IR heating system to reach the specimen surface. The aluminum support cylinder shall be rigidly attached to the distribution chamber, but the quartz pipe shall be removable.

6.8 *Water-Cooled Shield*—To prevent the specimen from being exposed to the IR heaters during the one minute heater stabilization period, there shall be a shield (see Fig. 8) consisting of two aluminum cylinders welded together with an inlet and outlet for water circulation. An electrically-actuated, pneumatic piston shall raise the shield to cover the specimen during test preparation and shall lower the shield within 1 s to expose the specimen at the start of a test.

6.9 *Exhaust System*—The exhaust system shall consist of

the following main components: an intake funnel (Figs. 9 and 10), a mixing duct (Fig. 11), a test section (Fig. 12), duct flanges (Fig. 13), and a high temperature blower to draw gases through the intake funnel, mixing duct and test section at variable flow rates up to $0.25 \text{ m}^3/\text{s}$. The intake funnel, mixing duct and test section shall be coated internally with fluorinated ethylene propylene (FEP) resin enamel and finish layers over a suitable primer to form a three layer coating that shall withstand temperatures of at least 200°C .

6.10 *Test Section Instruments:*

6.10.1 *Test Section Thermocouple Probe*—A thermocouple probe, inserted through a test section port, shall be positioned such that the exposed, type K measurement bead is at the center of the test section, at the axial position of the gas sampling port. Fabricate the thermocouple probe of wire no larger than 0.254-mm diameter for measurement of gas temperature with a time response (in the specified exhaust flow) of no more than 1 s and an accuracy of 1.0°C .

6.10.2 *Averaging Pitot Probe and Pressure Transducer*—An averaging Pitot probe, inserted through a test section port 220 to 230 mm downstream of the thermocouple port, shall measure the mass flow rate of the gas stream using at least four sets of flow sensing openings, one set facing upstream and the second downstream and shall be designed for compatibility with the test section diameter. Measure the differential pressure generated by the probe with an electronic pressure transducer (electronic manometer). The measured differential pressure is proportional to the square of the flow rate. Experience has shown that the averaging Pitot probe in this application is reliable (not susceptible to plugging), while minimizing pressure losses in the exhaust system.

6.11 *Heat-Flux Gage*—For calibration of the IR heating system, use a Gardon type, or equivalent, total heat-flux gage having a nominal range of 0 to $100 \text{ kW}/\text{m}^2$ and a flat, 6 to 8-mm diameter sensing surface coated with a durable, flat-black finish. The body of the gage shall be cooled by water above the dew point of the gage environment. The gage shall be rugged and maintain an accuracy of within $\pm 3\%$ and a repeatability within 0.5% between calibrations. Check the calibration of the heat-flux gage monthly through the use of a black-body oven calibration facility that compares the gage response to that of a NIST-traceable optical pyrometer. Alternatively, compare the gage output to that of a reference standard.

6.12 *Digital Data Collection System*—Digitally record the output from the CO , CO_2 , hydrocarbon gas, O_2 combustion and O_2 inlet-air analyzers, the load cell, the test section duct thermocouple, and the electronic pressure transducer at 1 s intervals. Time shift the data for the gas concentrations to account for delays within the gas sampling lines and respective instrument response times. The data collection system shall be accurate to within $\pm 1^\circ\text{C}$ for temperature measurement and $\pm 0.01\%$ of full-scale instrument output for all other channels. The system shall be capable of recording data for at least 1 h at 1-s intervals, although test duration typically is between 8 and 15 minutes.

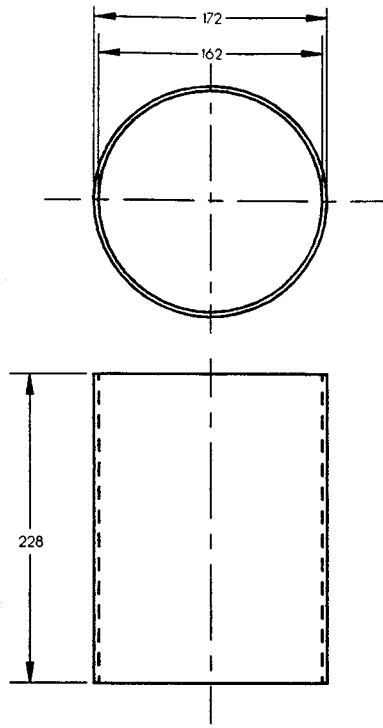

QUARTZ PIPE EXTENSION
ALL DIMENSIONS ARE mm UNLESS NOTED

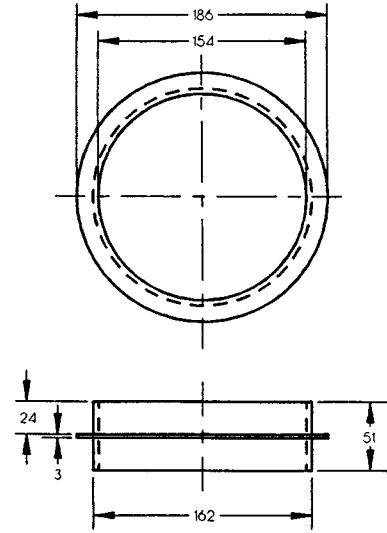

STAINLESS STEEL CONNECTOR
ALL DIMENSION ARE mm UNLESS NOTED

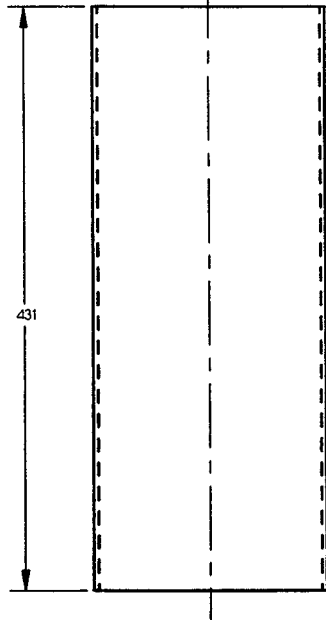
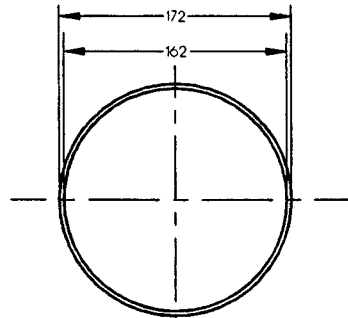

QUARTZ PIPE
ALL DIMENSIONS ARE mm UNLESS NOTED

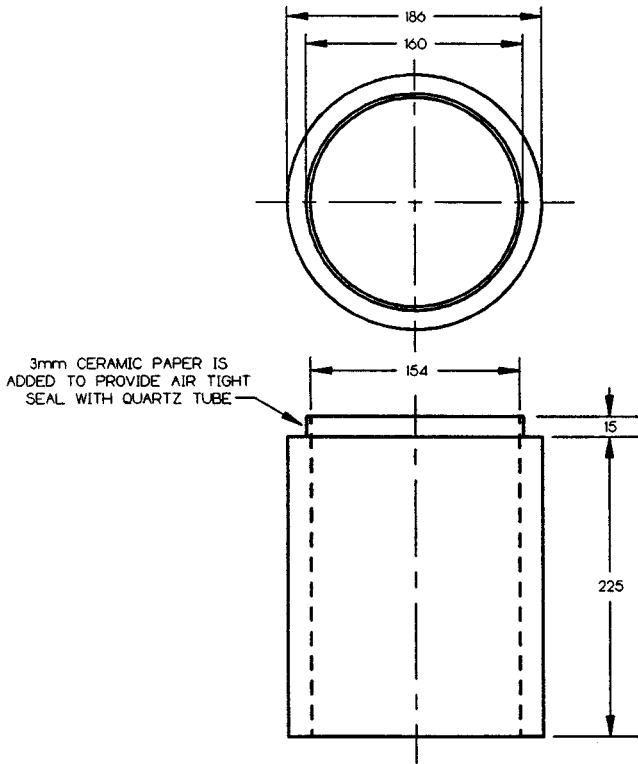

ALUMINUM CYLINDER TO SUPPORT PIPE
ALL DIMENSIONS ARE mm UNLESS NOTED

FIG. 7

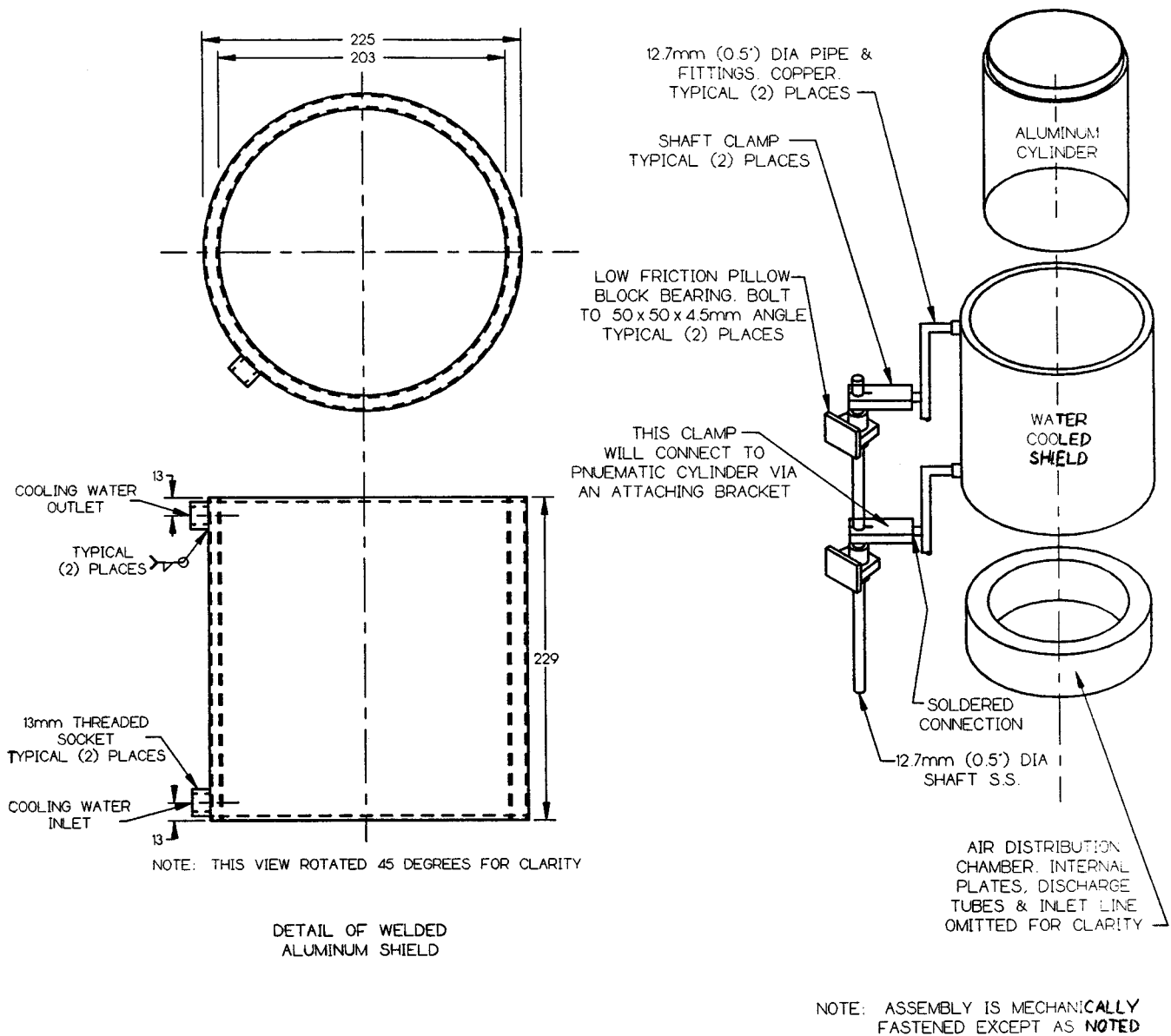

NOTE 1—All dimensions are mm unless noted.

FIG. 8 Water Cooled Shield

7. Hazards

7.1 All normal laboratory safety precautions must be followed since the test procedures involve high temperatures and combustion reactions, as well as the use of electric radiant heaters, laboratory glassware, and different types of compressed gases.

7.1.1 Hazardous conditions leading, for example, to burns, ignition of extraneous objects or clothing, and inhalation of combustion products, may exist. During the operation of the apparatus, the operator must use hearing protection and at least shade five welding goggles or glasses. The operator must use protective gloves for insertion and removal of test specimens. Specimens must be removed to a fume hood. Neither the heaters nor the associated fixtures can be touched while hot except with protective gloves.

7.1.2 The exhaust system must be checked for proper

operation before testing and must be discharged away from intakes for the building ventilation system. Provision must be made for collecting and venting any combustion products that fail to be collected by the exhaust system.

8. Test Specimen

8.1 *Specimen Holders*—Four types of specimen holders are used: horizontal square; horizontal circular (Fig. 14); a vertical specimen holder (Fig. 15); and, a vertical cable specimen holder (Fig. 16). The horizontal square holder consists of two layers of 2-mil (0.05-mm thickness) aluminum foil molded to the sides and bottom of a square specimen. The horizontal circular holder is a 0.099-m (3.9-in.) diameter aluminum dish (see Fig. 14). The vertical specimen holder is a 0.485-m (19-in.) high \times 0.133-m (5.2-in.) wide ladder rack (see Fig. 15). The vertical cable holder is 0.825-m high (see Fig. 16) and

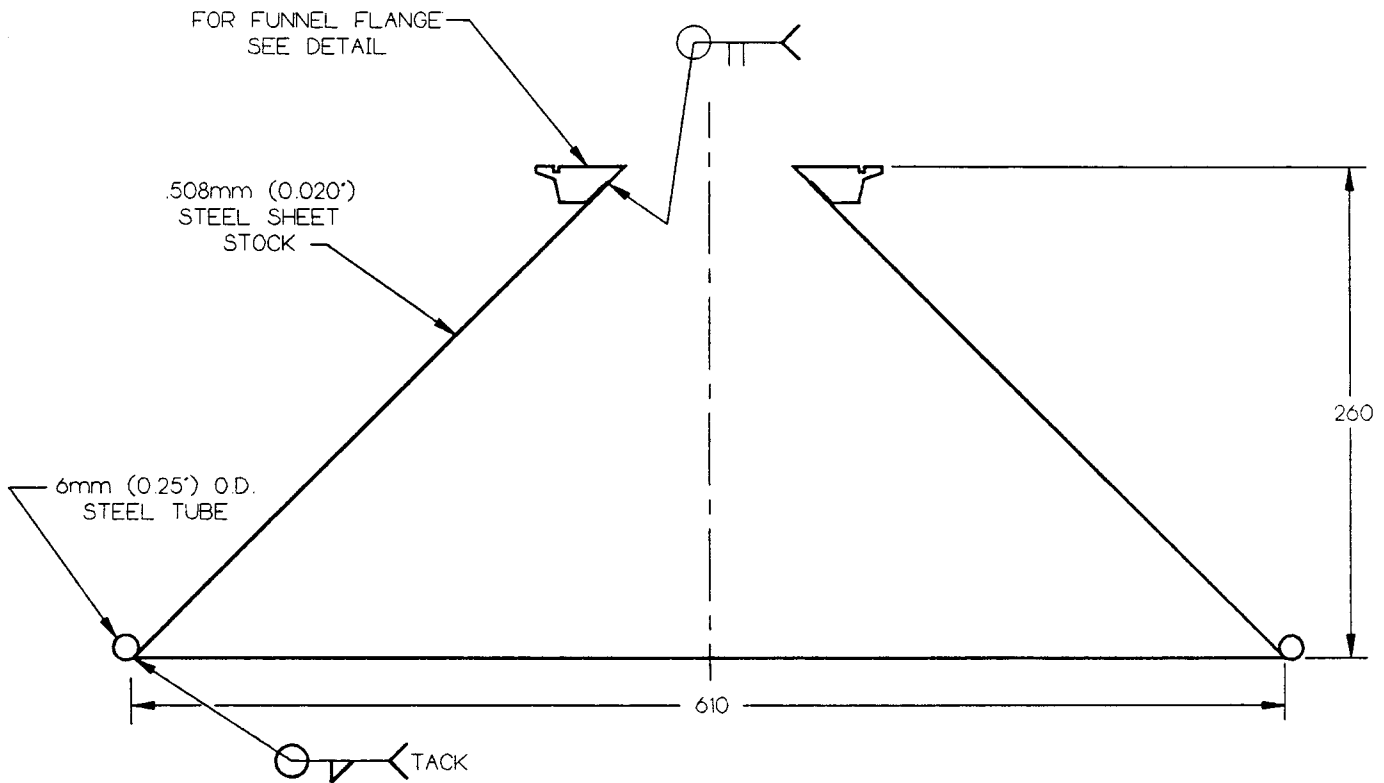

NOTE 1—Coat inside of funnel with FEP after welding.
 coat thickness: 0.5 mm
 All dimensions are in mm unless noted.

FIG. 9 Intake Funnel

can support a cable specimen 0.81 m (32.5 in.) long and up to 51-mm (2-in.) diameter.

8.2 Specimen Size and Preparation:

8.2.1 Ignition and Combustion Tests of Horizontal Specimens—Cut specimens from essentially planar materials or products to be 101.6 by 101.6 mm (4 by 4 in.) in area. Specimens shall have a thickness of no less than 3 mm and no more than 25.4 mm and be representative of the end-use material or product. For testing, place the square specimen in the horizontal square holder. Place granular or cable specimens in the horizontal circular holder, with the cable specimens cut to cover the center and at least 20-mm on each side of the center of the aluminum dish. Spray the exposed top surface of the specimen with a single coat of flat black paint⁵ that is designed to withstand temperatures of $540 \pm 10^\circ\text{C}$. Prior to testing, cure the paint coating by conditioning the specimen at a temperature of $23 \pm 3^\circ\text{C}$ and a relative humidity of $50 \pm 5\%$ for 48 h. This coating is applied to insure surface absorption of the imposed radiant heat flux. Place the holder containing the specimen on a 13-mm thick, calcium silicate board (density $700\text{--}750\text{ kg/m}^3$, thermal conductivity $0.11\text{--}0.13\text{ W/m K}$) having the same dimensions as the holder, as shown in Fig. 2, just before a test is to be performed.

⁵ Thuralox® Solar Collector Coating, No. 250 Selective Black spray paint, packaged for the Dampney Company, 85 Paris St., Everett, MA 02149, is suitable for this purpose.

8.2.2 Fire Propagation Test of Vertical, Rectangular Specimens:

8.2.2.1 Cut specimens from essentially planar materials or products to be 101.6 mm in width and 305 mm in height (4 by 12 in.). Specimens shall have a thickness of no less than 3 mm and no more than 13 mm and be representative of the end-use material or product.

8.2.2.2 Place ceramic paper (density $190\text{--}200\text{ kg/m}^3$) of 3.2 mm (0.125 in.) thickness to cover the sides and back surface of the specimen and then wrap the specimen, with the ceramic paper, in two layers of aluminum foil of 2-mil (0.05-mm) thickness to expose only the front surface to be tested.

8.2.2.3 Wrap the covered and exposed width of the specimen securely with one turn of No. 24-gage nickel/chromium wire at distances of 50-mm from each end and at the midpoint of the 305-mm length of the specimen.

8.2.2.4 Place the bottom of the specimen on the metal base-plate (see Fig. 15l) of the vertical holder with the covered (back) surface of the specimen against the ladder rack.

8.2.2.5 Wrap one turn of No. 24 gage nickel/chromium wire securely around the specimen, the ladder rack and the threaded rods at distances of 100 and 200 mm from the bottom of the specimen to keep the specimen firmly in contact with the vertical specimen holder.

8.2.3 Fire Propagation Test of Vertical, Cable Specimens:

8.2.3.1 Mount cable specimens as explained in Fig. 16.

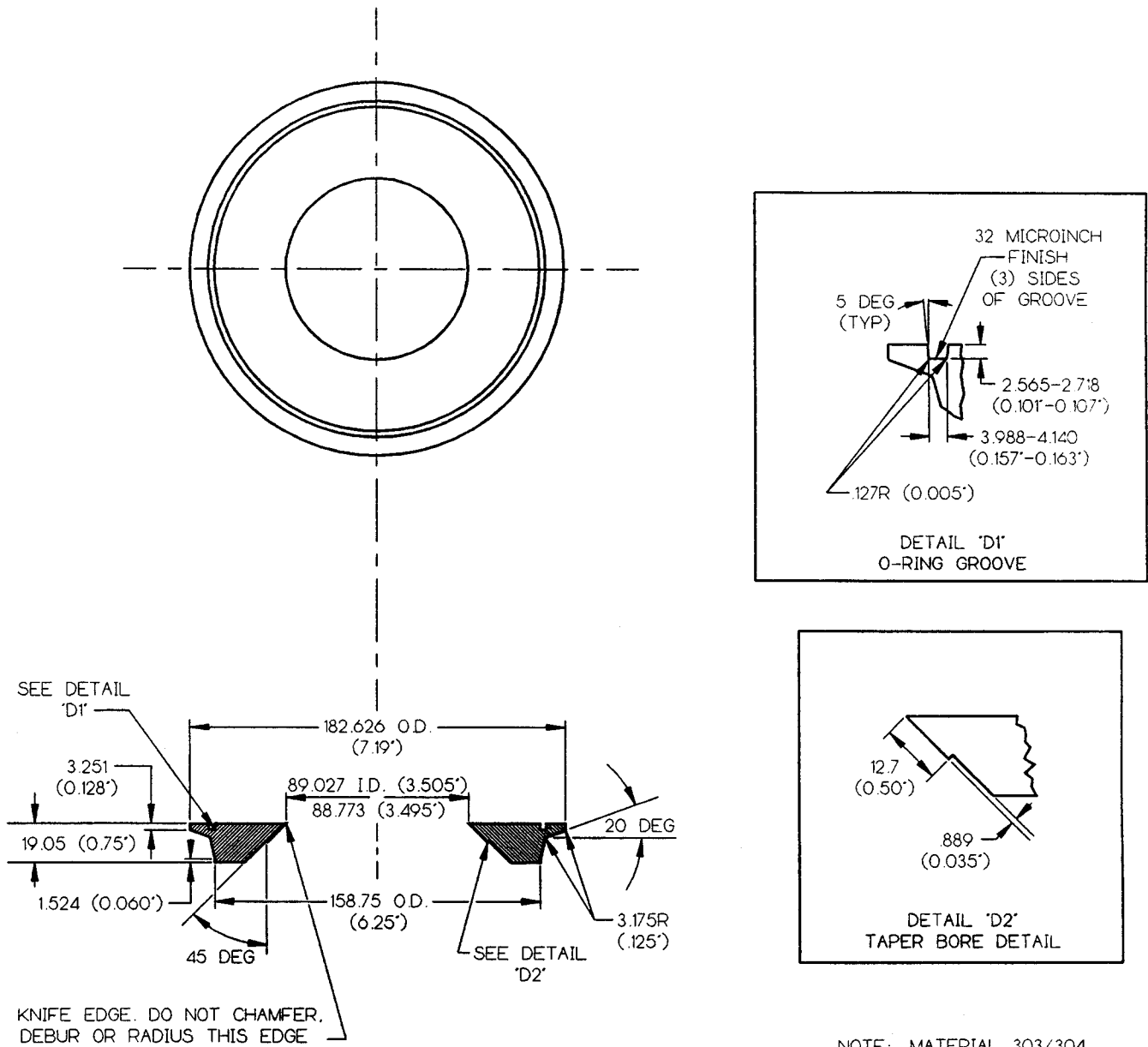

NOTE 1—All dimensions are in mm unless noted.

FIG. 10 Funnel Flange

NOTE: MATERIAL 303/304

8.3 Expose composite specimens in a manner typical of the end-use condition.

8.4 If the preparation techniques in 8.2 do not retain specimens within the specimen holder during combustion, specify the exact mounting and retaining methods used in the test report.

9. Calibration

9.1 Radiant-Flux Heater:

9.1.1 *Routine Calibration*—Calibrate IR heaters at the start of the test day. Clean the quartz windows, lamps, and back reflective surfaces of the heaters to keep them free of any impurity buildup or scratches. Position the heat-flux gage-sensing surface to be horizontal, at a location equivalent to the center of the top surface of a horizontal specimen. Place the

quartz pipe in position, as required, and record IR heater voltage settings and measured radiant flux levels for planned tests.

9.1.2 *Positioning of Radiant-Flux Heaters*—At least annually, check the position of the IR heaters. Set the heater voltage at 90 % of the maximum value. Position the heat-flux gage sensing surface to be horizontal and measure the heat flux at each of five locations, corresponding to each corner and the center of a square, horizontal specimen, at an elevation equivalent to that of the specimen top surface. Adjust the position of each IR heater symmetrically and repeat these heat flux measurements, if necessary, until there is at most a 5 % mean deviation of the five readings from the average value. Then, position the heat-flux gage to locations equivalent to the

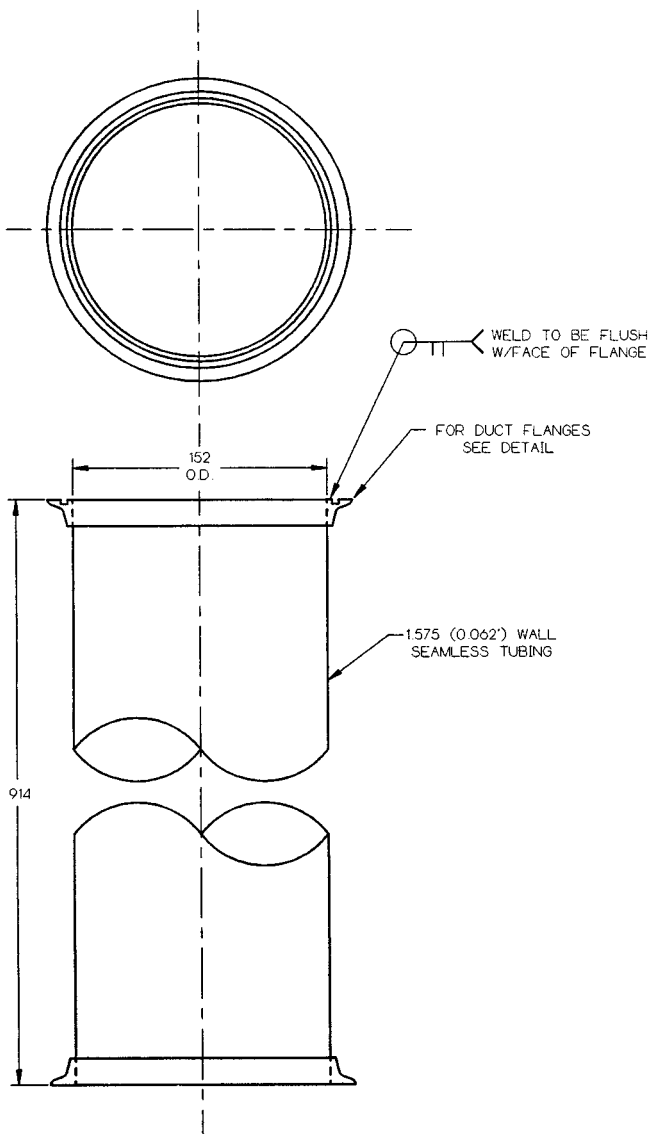

NOTE 1—Flanges to be square with tube.
Coat inside of duct with FEP after welding.
Material 304 S.S.
All dimensions are in mm unless noted.

FIG. 11 Mixing Duct

vertical axis at the center of a square specimen. Measure the heat flux at elevations of 10 mm and 20 mm above and below that equivalent to the specimen top surface. Check that the heat flux at these four elevations is within 5 % of the value at the elevation of the specimen face.

9.2 Gas-Analyzer Calibration—Calibrate the carbon dioxide, carbon monoxide, oxygen, and total hydrocarbon analyzers before the first Combustion or Fire Propagation test of the day.

9.2.1 Carbon Dioxide/Carbon Monoxide Analyzers—Calibrate the CO₂ and CO analyzers for measurement of combustion gases by establishing a downscale calibration point and an upscale calibration point. Perform the upscale calibration with a “span gas” at the upper end of the range that will be used during actual sample analysis and use a “zero gas” for the

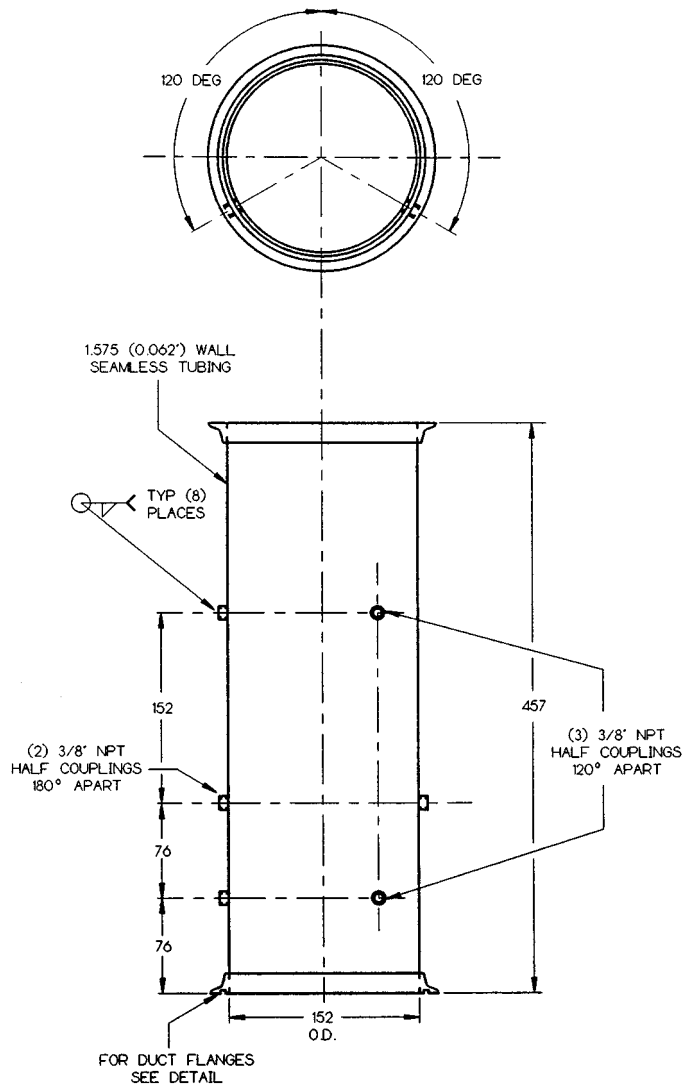

NOTE 1—Flanges to be square with tube.
Coat inside of duct with FEP after welding.
Material 304 S.S.
All dimensions are in mm unless noted.

FIG. 12 Test Section

down-scale calibration point at the lower end of the analyzer range. Use nitrogen as the “zero gas” reference source by turning on a Grade 5 nitrogen cylinder at 0.8 L/minute. Zero the CO and CO₂ analyzers. Span each analyzer with its appropriate gas for the corresponding range.

9.2.2 Oxygen Analyzer—Calibrate the oxygen analyzer for measurement of inlet oxygen concentration (and the optional oxygen analyzer for combustion gases) by establishing a downscale calibration point and an upscale calibration point. Perform the upscale calibration with a “span gas” at the upper end of the range that will be used during actual sample analysis and use a “zero gas” for the down-scale calibration point at the lower end of the analyzer range. To calibrate the analyzer, open the span gas at 1.0 L/minute, set the analyzer span, close the span gas, and open the zero gas at the same flow rate, and then set the lower end of the analyzer range. Re-span and re-zero several times, if necessary.

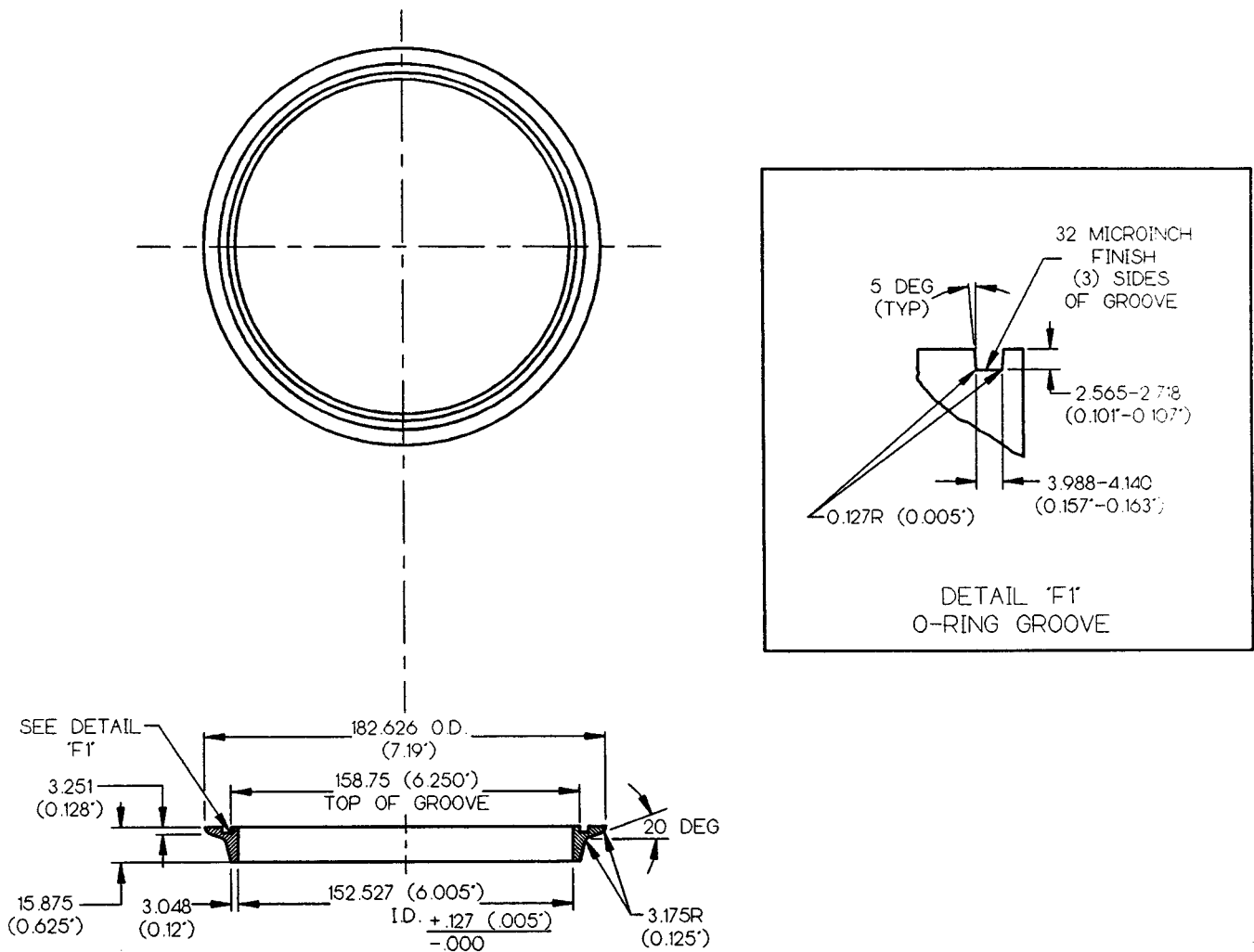

NOTE 1—Material 304 S.S.
 A matching pair consists of one flange with O-ring groove, and one flange without.
 All dimensions are in mm unless noted.

FIG. 13 Duct Flanges

9.2.3 *Optional Hydrocarbon Gas Analyzer*—Adjust the zero control of the analyzer by using ultra pure nitrogen flowing at 3 L/minute as the “zero gas”. As the “span gas,” use methane at a concentration that matches the operating range of the analyzer.

9.3 *Load Cell*—Calibrate the load cell each time it is used. Set the output voltage to zero by adjusting the tare, with the appropriate empty specimen holder in position. Then, place a NIST-traceable weight corresponding to the weight of the specimen to be tested on the empty holder and measure the output voltage. Check linearity by repeating this procedure with three other NIST-traceable weights so as to cover the entire specimen weight range.

9.4 *Heat Release Calibration*—Calibrate the heat release rate measurement process at least monthly to ensure the proper functioning of the FPA. Check that the measured effective heat of combustion of acetone is within $\pm 5\%$ of the reference value of 27 900 kJ/kg (4) and that the measured total delay (or lag) time of the gas analyzers is less than 15 s.

9.4.1 Do not use the IR heaters or the pilot.

9.4.2 Perform the rest of the required calibration procedures as described in this section.

9.4.3 Check that inlet air flow is set at 200 L/minute.

9.4.4 Start data acquisition program.

9.4.5 Place 100.0 mL of acetone in a specimen dish 0.097-m (3.8-in.) diameter on the load cell.

9.4.6 Ignite the acetone using a match 30 s after the start of data acquisition.

9.4.7 End data acquisition two minutes after the end of visible flaming.

9.4.8 Determine the effective heat of combustion following the calculation procedure in Section 12.

9.4.9 Determine the delay time for the gas analyzers by computing the difference between the time when the test section duct gas temperature reaches 50 % of its steady-state value and the time when the reading of each analyzer reaches 50 % of its steady-state value.

10. Conditioning

10.1 Condition specimens to moisture equilibrium (constant

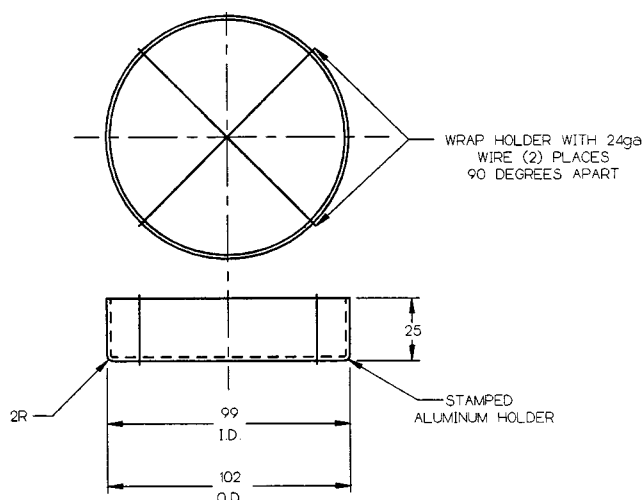

NOTE 1—This holder is used to hold and melting materials as well as powdered specimens.

All dimensions are in mm unless noted.

FIG. 14 Horizontal Circular Specimen Holder

weight) at an ambient temperature of $23 \pm 3^\circ\text{C}$ and a relative humidity of $50 \pm 5\%$ for 24 h.

11. Procedure

11.1 *Procedure 1: Ignition Test*—The ignition test is performed to determine the time required from the application of an externally applied heat flux to a horizontal test specimen until ignition of that specimen.

11.1.1 Verify that nitrogen for flame extinguishment is available for flow at 100 ± 10 L/minute and that pilot flame gases (ethylene to air ratio 60:40) are regulated to give specified flame length when needed.

11.1.2 Place the 13-mm thick calcium silicate board supporting the appropriate horizontal specimen holder in position (centered) on the aluminum load platform (confirm that there is no quartz pipe in place, to insure natural air flow).

11.1.3 Turn on the exhaust blower.

11.1.4 Light the pilot flame and adjust for a 10-mm flame length.

11.1.5 Move the lighted pilot flame to a position 10-mm above the specimen surface and 10-mm from the perimeter of the specimen.

11.1.6 Turn on air and water to cool the infrared radiant heaters.

11.1.7 Raise the water-cooled shield surrounding the specimen holder to prevent specimen exposure to external heat flux.

11.1.8 Set the IR heater voltage to produce the desired heat flux and allow for one minute of stabilization.

11.1.9 Lower the water-cooled shield to expose the sample to the external heat flux. Simultaneously start a timer.

11.1.10 Record the time when vapors are first observed coming from the test specimen.

11.1.11 Record the time to ignition as the time duration from exposure to the external heat flux until sustained flaming (existence of flame on or over most of the specimen surface for at least a four-s duration). If there is no ignition after a 15-minute heat flux exposure time, turn off the IR heater voltage and stop the test.

11.1.12 If there is sustained flaming, turn off the IR heater voltage and introduce nitrogen to extinguish flames.

11.1.13 When the specimen has cooled sufficiently to be handled safely, remove the specimen to a ventilated environment.

11.1.14 Repeat this procedure for additional infrared heater settings, as required.

11.2 *Procedure 2: Combustion Test*—The combustion test is conducted to measure the chemical and convective heat release rates (\dot{Q}_{chem} and \dot{Q}_c), mass loss rate (\dot{m}) and to determine the EHC of a horizontal specimen.

11.2.1 Place the 13-mm thick calcium silicate board supporting the appropriate horizontal specimen holder in position (centered) on the aluminum load platform.

11.2.2 Verify that the gas sampling system is removing all water vapor and similarly condensable combustion products. If the sampling system flow meter indicates less than 10 L/minute, then replace sampling system filter elements.

11.2.3 Install fresh indicating desiccant and soot filter in the gas sampling line.

11.2.4 Ignite the flame in the hydrocarbon gas analyzer and check the flame out indicator on the front panel to assure that there is flame ignition.

11.2.5 Verify that nitrogen for flame extinguishment is available for flow at 100 ± 10 L/minute into the inlet-air supply line and that pilot flame gases (ethylene to air ratio 60:40) are regulated to give specified flame length when needed.

11.2.6 Turn on gas sampling pump and set correct sampling flow rate for each gas analyzer (gas analyzers, the electronic pressure transducer, and load cell are powered on at all times to maintain constant internal temperatures).

11.2.7 Perform required calibration procedures as specified in Section 9.

11.2.8 Turn on the exhaust and air-supply blowers servicing the apparatus.

11.2.9 Light the pilot flame and adjust for a 10-mm flame length.

11.2.10 Move the lighted pilot flame to a position 10-mm above the specimen surface and 10-mm from the perimeter of the specimen.

11.2.11 Turn on air and water to cool the infrared radiant heaters.

11.2.12 Install the quartz pipe on the mounting step in the aluminum oxidant supply pipe.

11.2.13 Raise the water-cooled shield to cover the specimen.

11.2.14 Set an inlet-air supply rate of 200 L/minute into the air distribution chamber. To change oxygen content of inlet air supply from that of normal air, introduce oxygen or nitrogen (from grade 2.6 and 4.8 cylinders, respectively) into the inlet-air supply line and check oxygen concentration with inlet-air oxygen analyzer (maximum oxygen concentration shall be 40 % by volume).

11.2.15 Set the IR heater voltage to produce the desired radiant exposure of the specimen surface and allow the IR heaters to stabilize for one minute.

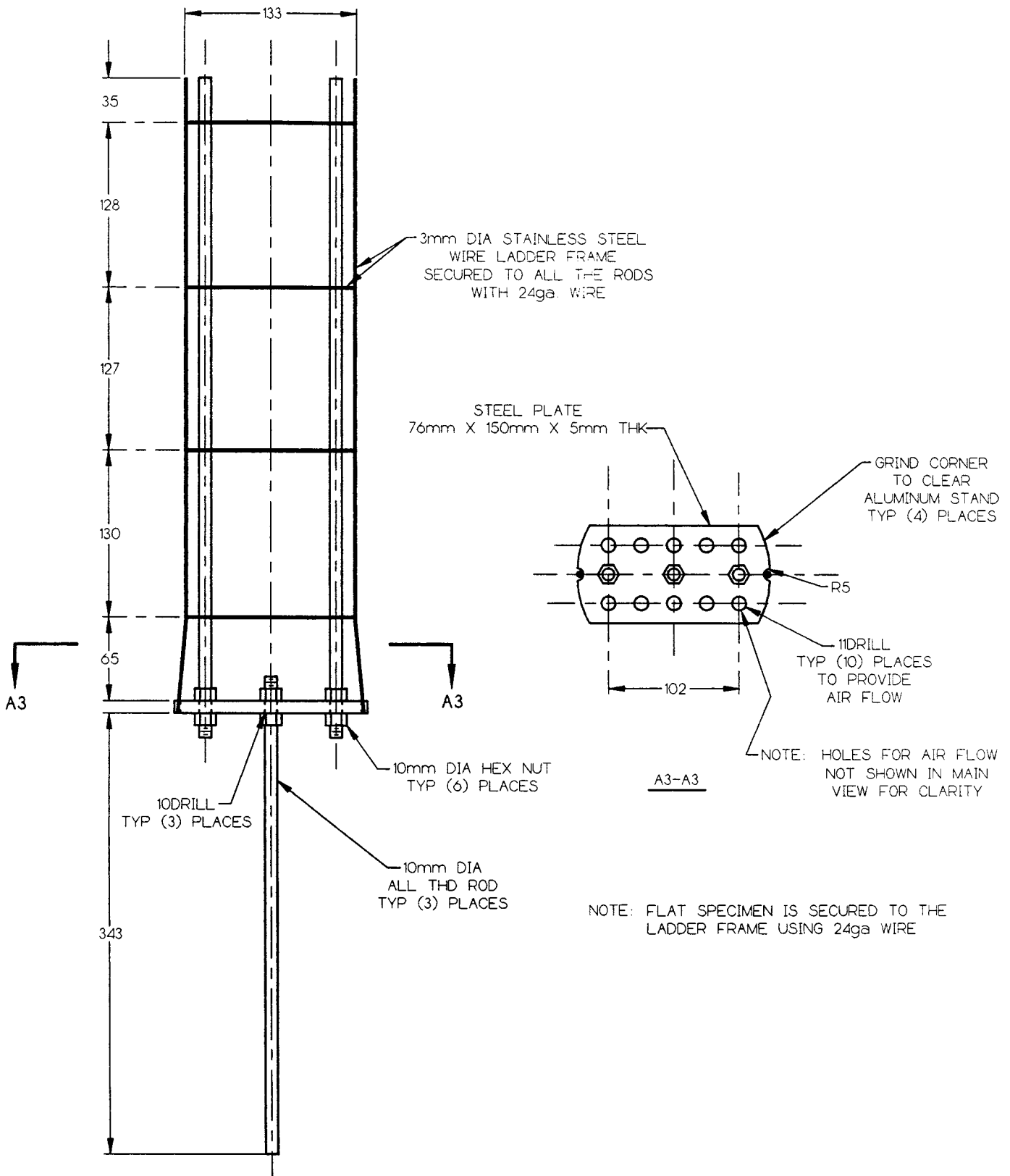

NOTE 1—All dimensions are in mm unless noted.

FIG. 15 Vertical Specimen Holder

11.2.16 Start the digital data collection system to record at 1-s intervals.

11.2.17 At 30 s, lower the cooling shield to expose specimen to infrared radiant heaters.

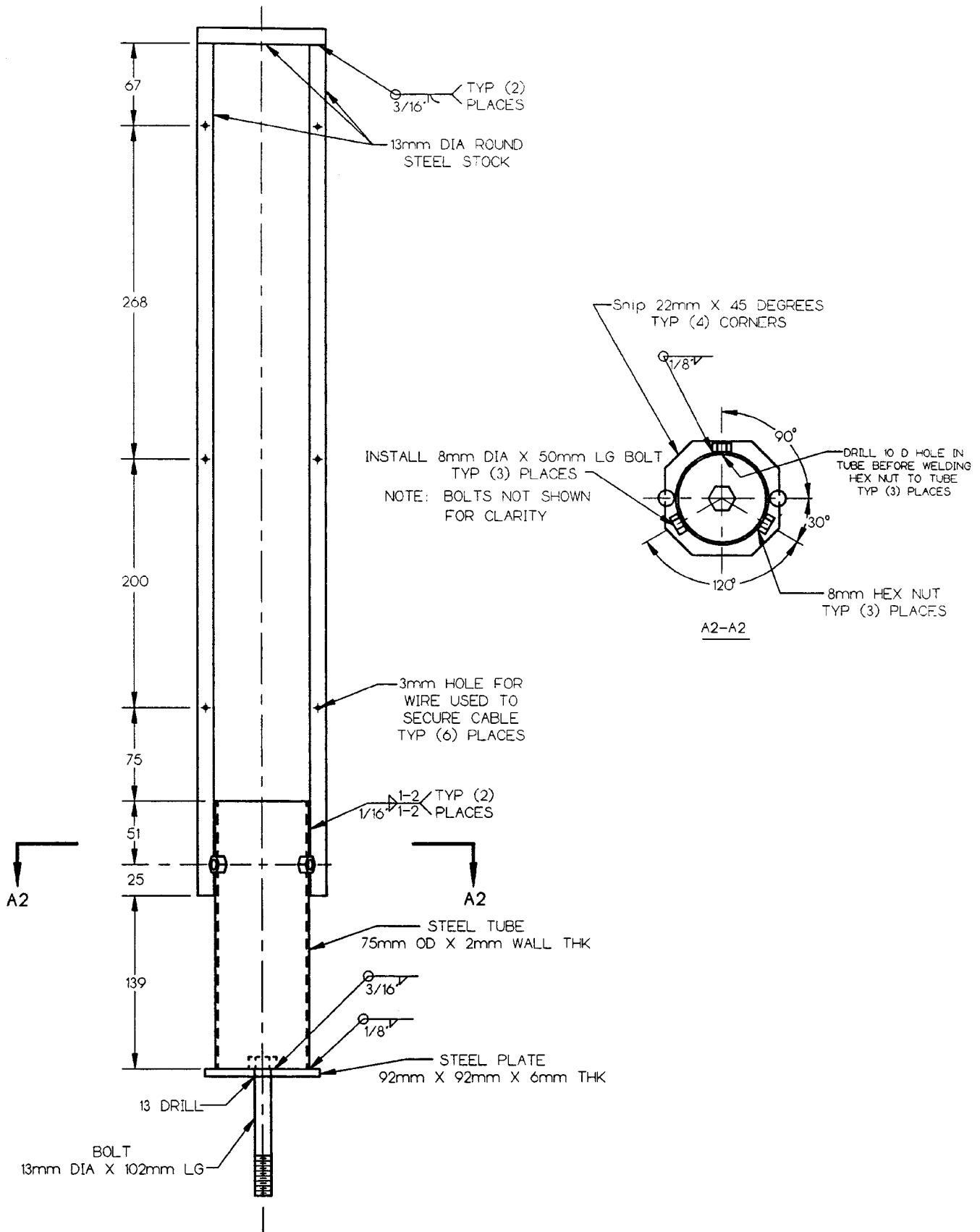

NOTE 1—The cable specimen is placed in the center of the holder with the lower end on the steel plate. It is secured by three tie wires and is centered by tightening the three bolts in the steel tube.
All dimensions are in mm unless noted.

FIG. 16 Cable Specimen Holder

11.2.18 Record the time when vapors are first observed coming from the test specimen, the time at ignition, flame height, flame color/smokiness, any unusual flame or specimen behavior and flame extinction time.

11.2.19 Maintain the position of the pilot flame to be a 10 ± 5 -mm height above the exposed surface of any specimen that regresses or expands during the test period.

11.2.20 Turn off the IR heaters and introduce nitrogen two minutes after the end of visible flaming or if flames reach 35 ± 10 mm above the rim of the collection funnel for more than 30 s.

11.2.21 When the specimen has cooled sufficiently to be safely removed from the specimen holder, weigh the residue and record the result.

11.2.22 Repeat the above procedures to give a total of three chemical heat release rate and mass loss rate determinations.

11.3 *Procedure 3: Fire Propagation Test*—The fire propagation test is performed to determine the chemical heat release rate (\dot{Q}_{chem}) of a vertical specimen during upward fire propagation and burning.

11.3.1 Repeat steps needed for measurement of heat release rate in 11.2.2-11.2.8, with the exception of the load cell calibration.

11.3.2 Remove the stainless steel load cell shaft and the ball-bushing bearings from the air distribution chamber and replace with the appropriate vertical specimen holder.

11.3.3 Install specimen such that the bottom edge of the vertical specimen that is to be exposed to IR heating is at an elevation equivalent to that of the top surface of a horizontal specimen.

11.3.4 Light the pilot flame and adjust for a 10-mm flame length.

11.3.5 Turn on air and water to cool the infrared radiant heaters.

11.3.6 Install the quartz pipe on the mounting step in the aluminum oxidant supply pipe.

11.3.7 Raise the water-cooled shield surrounding the specimen holder to prevent pre-exposure to external heat flux.

11.3.8 Move the pilot flame to a position 75 mm from the bottom of the specimen and 10 mm away from the specimen surface.

11.3.9 Set an inlet-air supply rate of 200 L/minute into the air distribution chamber. To change oxygen content of inlet air supply from that of normal air, introduce oxygen, or nitrogen (from grade 2.6 and 4.8 cylinders, respectively) into the inlet-air supply line and check oxygen concentration with inlet-air oxygen analyzer (maximum oxygen concentration shall be 40 % by volume).

11.3.10 Set the IR heater voltage to produce 50 kW/m^2 and allow to stabilize for one minute.

11.3.11 Start the digital data collection system to record at 1-s intervals.

11.3.12 At 30 s, lower the water-cooled shield to expose the lower portion of the vertical sample to the external heat flux from the infrared radiant heaters. Simultaneously start a timer.

11.3.13 After preheating the base area of the specimen for one minute, move the pilot flame into contact with the specimen surface to initiate fire propagation, if ignition and fire

propagation has not already occurred, and then move the pilot flame away from the specimen.

11.3.14 Measure the chemical heat release rate as a function of time during fire propagation, using the Combustion test procedures.

11.3.15 Record the time when vapors are first observed coming from the test specimen, the time at ignition, flame height at one-minute intervals, flame characteristics, such as color, and the time at flame extinction.

11.3.16 Turn off the IR heaters and introduce nitrogen two minutes after the end of visible flaming or if flames reach 35 ± 10 mm above the rim of the collection funnel for more than 30 s, or if the specimen undergoes noticeable structural deformation.

11.3.17 Repeat the above procedures to give a total of three heat release rate determinations.

12. Calculation

12.1 Determine the chemical heat release rate, \dot{Q}_{chem} , from the following expression, derived in X1.3:

$$\dot{Q}_{chem} = 13\,300 (\dot{G}_{CO_2} - \dot{G}_{CO_2}^0) + 11\,100 (\dot{G}_{CO} - \dot{G}_{CO}^0) \quad (1)$$

where:

\dot{G}_{CO_2} and \dot{G}_{CO} = the generation rates (kg/s) of CO_2 and CO, respectively, and

$\dot{G}_{CO_2}^0$ and \dot{G}_{CO}^0 = the corresponding measurements before ignition of the specimen.

Determine the generation rates of CO_2 and CO from the following expressions, derived in X1.3:

$$\dot{G}_{CO_2} = A_d K (P_{atm}/101\,000)^{1/2} (2 * 353 \Delta p_m/T_d)^{1/2} * 1.52 X_{CO_2} \quad (2)$$

$$\dot{G}_{CO} = A_d K (P_{atm}/101\,000)^{1/2} (2 * 353 \Delta p_m/T_d)^{1/2} * 0.966 X_{CO} \quad (3)$$

12.2 The convective heat release rate, \dot{Q}_c , is obtained as follows:

$$\dot{Q}_c = \dot{m}_d c_p (T_d - T_a) \quad (4)$$

where:

\dot{m}_d (kg/s) = the mass flow rate of combustion products in the test section duct (an expression for which is derived in X1.3),

c_p (kJ/kg•K) = the specific heat of air,

T_d (K) = the gas temperature in the test section duct, and

T_a (K) = the gas temperature in the test section duct just before pilot flame ignition occurs.

Correct the specific heat, c_p , for temperature as follows:

$$c_p = 1.00 + 1.34 * 10^{-4} T_d - 2590 / T_d^2 \quad (5)$$

In summary, determine the convective heat release rate from the following equation:

$$\dot{Q}_c = A_d K (P_{atm}/101\,000)^{1/2} (706 \Delta p_m/T_d)^{1/2} (1.00 + 1.34 * 10^{-4} T_d - 2590/T_d^2) (T_d - T_a) \quad (6)$$

12.3 Determine specimen mass loss rate, \dot{m} , from the slope of five-point, straight-line regression fits to the data on mass loss versus time. Compute the slope at each time using mass loss data from the current time record, from the two preceding time records and from the two succeeding time records.

12.4 Determine the effective heat of combustion, ΔH_{eff} , from the following expression:

$$\Delta H_{eff} = Q/M_{loss} \quad (7)$$

where:

- Q = the cumulative heat generated during the Combustion test, based on a summation over all data scans of the product of \dot{Q}_{chem} , from Eq 1, and Δt , the time between scans; and,
- M_{loss} = the change in measured specimen mass (by laboratory balance) resulting from the Combustion test.

13. Report

13.1 *Procedure 1: Ignition Test*—Report the following information:

- 13.1.1 Specimen identification code or number.
- 13.1.2 Manufacturer or name of organization submitting specimen.
- 13.1.3 Date of test.
- 13.1.4 Operator and location of apparatus.
- 13.1.5 Composition or generic identification of specimen.
- 13.1.6 Specimen thickness and dimensions of specimen surface exposed to IR heaters (mm).
- 13.1.7 Specimen mass (kg).
- 13.1.8 Details of specimen preparation.
- 13.1.9 Specimen orientation, specimen holder and description of special mounting procedures.
- 13.1.10 Room temperature (°C) and relative humidity (%).
- 13.1.11 Exhaust system flow rate (L/minute).
- 13.1.12 Radiant flux from IR heating system applied to test specimen (kW/m²).
- 13.1.13 Time when vapors are first observed coming from the test specimen (s).
- 13.1.14 Time at which there is ignition (sustained flaming) (s).
- 13.1.15 Additional observations (including times of transitional flaming, flashing, or melting).

13.2 *Procedure 2: Combustion Test*—In addition to 13.1.1-13.1.12, report the following information:

- 13.2.1 Chemical and convective heat release rates per unit exposed specimen area (kW/m²).

13.2.2 Generation rates of carbon monoxide, and carbon dioxide (kg/s).

13.2.3 Specimen mass loss rate (kg/s).

13.2.4 Effective heat of combustion, ΔH_{eff} (kJ/kg).

13.2.5 Specimen mass remaining after test (kg).

13.2.6 Number of replicate specimens tested under the same conditions.

13.3 *Procedure 3: Fire Propagation Test*—In addition to 13.1.1-13.1.12, report the following information:

13.3.1 Chemical and convective heat release rates per unit exposed specimen area (kW/m²).

13.3.2 Flame height at one-minute interval (m).

13.3.3 Number of replicate specimens tested under the same conditions.

14. Precision and Bias

14.1 *Intermediate Precision*—The precision of these test methods has not been fully determined, but the task group will be pursuing actively the development of data regarding the precision of these test methods.

14.1.1 Tables X2.1 and X2.2 contain some data on precision, based on tests conducted by two laboratories at the same organization. Within this very limited study, the maximum deviation from the mean value generally is within $\pm 10\%$ for three different commercial cable specimens and two different commercial conveyor belt specimens.

14.2 *Bias*:

14.2.1 The effective heat of combustion (kJ/kg) measured for acetone (see 9.4) is routinely within $\pm 5\%$ of the Ref (4) value.

14.2.2 Ignition times measured for poly (methyl methacrylate) are consistent with independent measurements for that plastic, as described in detail in Ref (5).

14.2.3 As shown in Tables 3-4.11 of Ref (4), the values of EHC obtained from Combustion tests of three different wood varieties are all within 7% of the EHC obtained for a fourth, similar wood variety using Test Method E 1354.

15. Keywords

15.1 effective heat of combustion; fire propagation apparatus; flammability characteristics; upward fire propagation

APPENDIX

(Nonmandatory Information)

X1. COMMENTARY

X1.1 Background

X1.1.1 The Fire Propagation Apparatus (FPA) was first developed and used by Factory Mutual Research Corporation (FMRC) during the mid-1970s. The apparatus collects the flow of combustion gases from a burning test specimen, and then conditions this flow to uniform velocity, temperature, and species concentration within the test section duct, where

measurements are made. As described in Ref (6), this uniformity is achieved by passing the flow through an orifice at the entry to a mixing duct six duct diameters upstream of the test section.

X1.2 Terminology

X1.2.1 *Definitions of Terms Used Only in This Commentary*:

X1.2.1.1 *fire propagation index, FPI*, ($m^{5/3}/kW^{2/3} s^{1/2}$), n —the propensity of a material to support fire propagation beyond the ignition zone, determined, in part, by the chemical heat release rate during upward fire propagation in air containing 40 % oxygen.

X1.2.1.2 *thermal response parameter, TRP*, ($kW \cdot s^{1/2}/m^2$), n —a parameter characterizing resistance to ignition upon exposure of a specimen to a prescribed heat flux.

X1.2.2 *Symbols:*

NOTE X1.1—The following symbols are used only in this commentary.

- \dot{D}_{O_2} = mass consumption rate of oxygen (kg/s)
- \dot{G}_j = mass flow rate of compound j in test section duct (kg/s)
- ΔH_{CO} = heat of complete combustion per unit mass of CO (kJ/kg)
- ΔH_{CO_2} = heat of complete combustion per unit mass of CO₂ (kJ/kg)
- ΔH_{O_2} = heat of complete combustion per unit mass of oxygen (kJ/kg)
- ΔH_T = net heat of complete combustion per unit mass of fuel vaporized (kJ/kg)
- k_{CO_2} = stoichiometric CO₂ to fuel mass ratio, for conversion of all fuel carbon to CO₂ (-)
- k_{CO} = stoichiometric CO to fuel mass ratio, for conversion of all fuel carbon to CO (-)
- k_{O_2} = stoichiometric ratio of mass of oxygen consumed to mass of fuel burned (-)
- MW_j = ratio of the molecular weight of compound, j , to that of air (-)
- \dot{v} = total volumetric flow rate in test section duct (m³/s)
- W = width of a flat specimen or the circumference of a cable specimen (m)
- X_j = measured analyzer reading for compound, j , or mole fraction of compound, j (-)
- ρ = gas density in test section duct (kg/m³)

X1.3 Details of Heat Release Rate Calculation

X1.3.1 Total volumetric and mass flow rates of product-air mixture through the test section are calculated from measurements of volumetric flow, \dot{v} , and density of the flow, ρ , in the test section duct. Using these measurements, the duct mass flow rate, \dot{m}_d , is calculated from the following relationship by assuming the mixture is essentially air:

$$\dot{m}_d = \dot{v} \rho \quad (X1.1)$$

The volumetric flow, \dot{v} (m³/s), in the test section duct is given by:

$$\dot{v} = A_d K (P_{atm}/101\ 000)^{-1/2} (2 \Delta p_m T_d/353)^{1/2} \quad (X1.2)$$

where:

- A_d = test section duct cross sectional area (m²)
- K = flow coefficient of the averaging Pitot tube (-)
- P_{atm} = the actual atmospheric pressure (Pa)
- Δp_m = pressure differential across the averaging Pitot tube in the test section duct (Pa)
- T_d = gas temperature in the test section duct, measured by a thermocouple (K), and
- 353 (kg K/m³) = $\rho * T_d$ for air, at an atmospheric pressure of 101 kPa.

X1.3.2 The density of air, ρ (kg/m³), assumed to be ideal, can be expressed as follows:

$$\rho = [353 (P_{atm}/101\ 000)]/T_d \quad (X1.3)$$

X1.3.3 From Eq X1.1-X1.3, the mass flow rate, \dot{m}_d (kg/s), is determined as follows:

$$\dot{m}_d = A_d K (P_{atm}/101\ 000)^{1/2} (2 * 353 \Delta p_m/T_d)^{1/2} \quad (X1.4)$$

X1.3.4 The mass generation rate, \dot{G}_j (kg/s), of CO₂ or CO or compound j , is expressed as:

$$\dot{G}_j = \dot{m}_d X_j MW_j \quad (X1.5)$$

where:

- \dot{m}_d = the duct mass flow rate from Eq X1.4,
- X_j = the measured volume ratio or mole fraction of compound, j , (-), and
- MW_j = the ratio of the molecular weight of compound, j , to that of air.

X1.3.5 The heat generated by chemical reactions in fires, defined as chemical heat, is calculated from the following relationships, based on generation rates of CO and CO₂ and consumption rate of O₂:

$$\dot{Q}_{chem} = (\Delta H_T/k_{CO_2}) (\dot{G}_{CO_2} - \dot{G}_{CO_2}^0) + [(\Delta H_T - \Delta H_{CO} k_{CO}) / k_{CO}] (\dot{G}_{CO} - \dot{G}_{CO}^0) \quad (X1.6)$$

$$\dot{Q}_{chem} = (\Delta H_T/k_{O_2}) \dot{D}_{O_2} \quad (X1.7)$$

where:

- \dot{Q}_{chem} = the chemical heat release rate (kW),
- ΔH_T = the net heat of complete combustion (kJ/kg),
- ΔH_{CO} = the heat of combustion of CO (kJ/kg),
- \dot{G}_{CO} and \dot{G}_{CO_2} = the generation rates of CO and CO₂, respectively ($\dot{G}_{CO_2}^0$ and \dot{G}_{CO}^0 represent values prior to ignition, and
- \dot{D}_{O_2} = the consumption rate of O₂ (kg/s),
- k_{CO_2} = the stoichiometric yield of CO₂ when all the carbon present in the material is converted to CO₂ (kg/kg),
- k_{CO} = the stoichiometric yield of CO (kg/kg), and

k_{O_2} = the mass stoichiometric oxygen to fuel ratio (kg/kg). The net heat of complete combustion is measured in an oxygen bomb calorimeter and the values of k_{CO_2} , k_{CO} and k_{O_2} can be calculated from the measured elemental composition of the specimen material. It is also acceptable to obtain the coefficients of ($\dot{G}_{CO_2} - \dot{G}_{CO_2}^0$) and ($\dot{G}_{CO} - \dot{G}_{CO}^0$) in Eq X1.6 or the coefficient of \dot{D}_{O_2} in Eq X1.7, for the particular type of material being tested, from values tabulated in Ref (4) for that material type.

X1.3.6 Analysis of the thermodynamics of more than 20 different classes of solids, liquids, and gases, described in Ref (4), shows that average values for the coefficients of ($\dot{G}_{CO_2} - \dot{G}_{CO_2}^0$) and ($\dot{G}_{CO} - \dot{G}_{CO}^0$) in Eq X1.6 are 13 300 ($\pm 11\%$) kJ/kg and 11 100 ($\pm 18\%$) kJ/kg, respectively, as opposed to 12 800 ($\pm 7\%$) kJ/kg for the coefficient of \dot{D}_{O_2} in Eq X1.7. Use of constant coefficients to determine chemical heat release rate is thus less accurate when using the CO₂ and CO generation method (mainly determined by the CO₂ uncertainty, since CO concentrations are generally very small in comparison) than for the oxygen depletion method. This inaccuracy in the use of constant coefficients is offset partly by the greater accuracy available for the direct measurement of CO₂ and CO concentrations, than that for depletion of oxygen, at low heat release rates. In both cases, accuracy is improved if the composition of the test specimen is known or is able to be assigned to one of the categories listed in Ref (4).

X1.4 Application of the Test Methods to the Evaluation of Cable Insulation, Clean Room Materials and Conveyor Belting Using a Fire Propagation Index

X1.4.1 *Background Information*—As part of the standards cited in 2.2, a Fire Propagation Index (FPI) is calculated, based on the concept that fire propagation is related both to the heat flux from the flame of a burning material and to the resistance of a material to ignite (7,8). Flame heat flux is derived from the chemical heat release rate per unit width of a vertical specimen during upward fire propagation and burning in air containing 40 % oxygen (needed to simulate the radiant heat flux from real-scale flames, as discussed in X1.5 and in Refs 9 and 10). Resistance of a material to ignite is derived from the change in ignition time with changes in incident heat flux.

X1.4.2 *Calculation of FPI*—The fire propagation index is obtained from the following expression:

$$FPI = 1000 [(0.42 \dot{Q}_{chem})/W]^{1/3}/TRP \quad (X1.8)$$

where:

\dot{Q}_{chem} = a result from the Fire Propagation test performed with an inlet air supply containing 40 % oxygen,
 W = the width of the vertical, essentially planar specimen or the circumference of the vertical cable specimen used in the Fire Propagation test, and
 TRP = the thermal response parameter, discussed in X1.4.3.

X1.4.3 *Calculation of TRP from Ignition Test Results:*

X1.4.3.1 The thermal response parameter is the slope of a

straight-line regression fit to values for incident heat flux (from the IR heaters) versus values for the inverse of the square root of t_{ign} . Ignition time results for this slope calculation correspond to incident heat flux values of 45, 50, 55, and 60 kW/m². If the standard deviation (standard error) of the slope due to data scatter is not within 10 % of the regression fit slope, additional ignition time results are obtained.

X1.4.3.2 Fig. X1.1 illustrates the TRP calculation described in X1.4.3.1. Ignition times, t_{ign} , from a typical test are shown in Fig. X1.1. A linear regression fit to the four highest external heat flux values (45, 50, 55, and 60) is shown as the solid line in the figure. Regression software⁶ yields the slope of this fit, which equals the TRP, as well as, the standard deviation (standard error) of the slope. Lines having a slope one standard deviation greater than and one standard deviation less than the TRP also are shown in Fig. X1.1. In this case, the data scatter is acceptable since the standard deviation is less than 10 % of the TRP.

X1.5 Background on the Use of a 40 % Oxygen Concentration for the Fire Propagation Test

X1.5.1 A key feature of the fire propagation index (FPI) discussed in X1.4 is the use of Fire Propagation test results obtained for an inlet air supply containing a 40 % oxygen concentration. This is done to simulate, in a small-scale apparatus, the radiant heat flux from real-scale flames in various fire situations.

X1.5.2 It is shown in Refs (4 and 10) that flame radiant heat flux associated with a variety of burning polymeric materials increases as the ambient oxygen concentration in air is increased, with radiant flux reaching an asymptotic value near an oxygen concentration of 40 %. This result is not surprising in view of the fact that increasing the oxygen concentration in normal air increases flame temperatures somewhat and increases soot production reaction rates substantially; hence, flames in air having a 40 % oxygen concentration would be expected to have higher concentrations of luminous soot particles to radiate much more efficiently than flames in normal air.

X1.5.3 The following table, extracted from Table 1 in Ref (10), illustrates the point made in X1.5.2 for a Combustion test of a 0.093-m diameter specimen of polypropylene without the use of the IR heaters (see Table X1.1).

X1.5.4 Table X1.1 shows that the calculated flame radiant flux from a laboratory-scale specimen is only 14 kW/m² in normal air (21 % oxygen) but increases to the level of 40 to 50 kW/m² characteristic of large-scale fires (4) when the oxygen concentration is increased to 40 %.

X1.6 Real-Scale Fire Behavior and the Fire Propagation Index of Cable Insulation, Clean Room Materials and Conveyor Belting

X1.6.1 Values of fire propagation index (FPI, see X1.4), as well as, fire propagation behavior during real-scale tests are discussed in Ref (8) for electrical cables insulated with polymeric material and in Ref (11) for solid panels of polymeric clean room materials. The real-scale tests involved fires

⁶ The LINESST function in Microsoft Excel is suitable for this purpose.

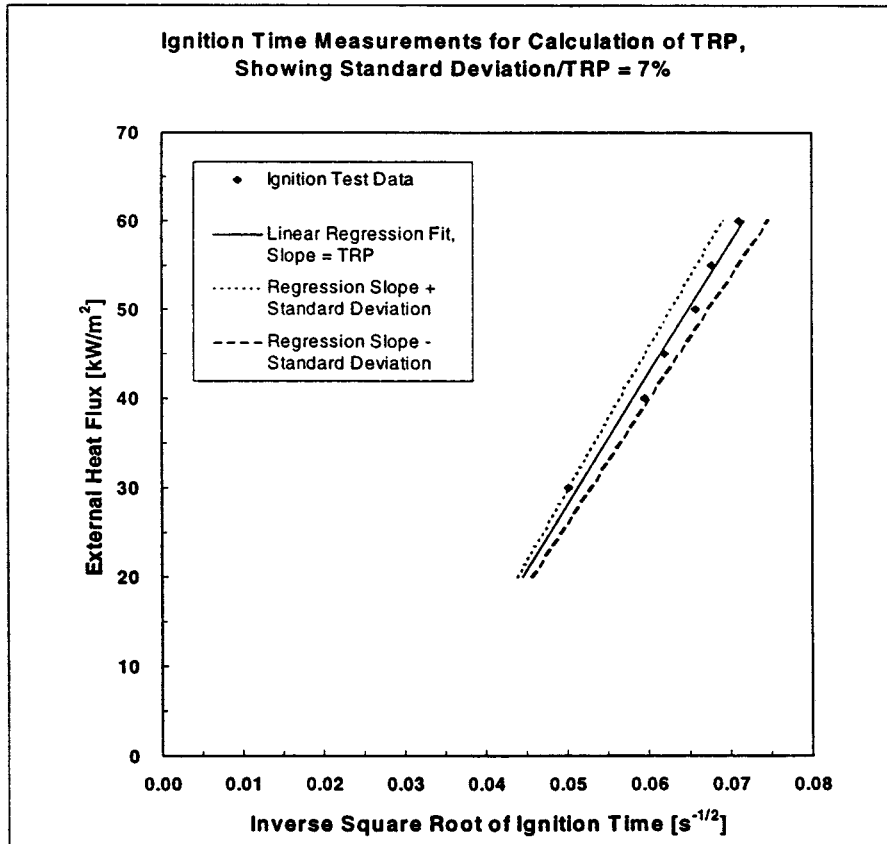

FIG. X1.1 Ignition Time Measurements for Calculation of TRP, Showing Standard Deviation/TRP = 7 %

TABLE X1.1 Effect of Oxygen Concentration on Flame Radiant Flux from a 93-mm Diameter Polypropylene Specimen in the Absence of External Heating

Oxygen Concentration in Air, %	Flame Radiant Heat Flux, kW/m ²
21	14
24	23
28	37
34	41
40	44
47	53

TABLE X1.2 Comparison of FPI Value with Real-Scale Fire Propagation Behavior

Material Composition and Arrangement ^A	FPI from Fire Propagation Test Method, m ^{5/3} /kW ^{2/3} s ^{1/2}	Fire Propagation Beyond the Ignition Zone at Real-Scale ^B
Gray PVC panel	4	None
PVDF panel	5	None
White PVC panel	6	None
Rigid, Type I PVC panel	8	Limited
Modified FRPP panel	9	Yes
ETFE panel	9	Limited
FRPP panel	>10	Yes
PMMA panel	>10	Yes
XLPE/Neoprene cable	9	Limited
PVC/PVDF cable	7	None
XLPO cable	9	Limited
XLPE/EVA cable	7	Limited
PE/PVC cable	20	Yes
CR or PVC conveyor belts	<6	None
CR or SBR conveyor belts	7 to 8	Limited
PVC or SBR conveyor belts	>8	Yes

initiated by a 60 kW propane sand-burner located between vertical, parallel arrays of the cables or clean room materials. In addition, values of FPI for conveyor belts, as well as, fire propagation behavior of these belts in a U.S. Bureau of Mines large-scale fire test gallery, are discussed in Ref (12). Fires in the large-scale gallery were initiated by a burning flammable liquid pool.

X1.6.2 Table X1.2, extracted from Table 1 in Ref (11) and from information in Ref (12), illustrates how the Fire Propagation Index is related to real-scale fire propagation behavior shown in Table X1.2.

X1.6.3 Table X1.2 shows that a Fire Propagation Index equal to or less than a value of 6 m^{5/3}/kW^{2/3} s^{1/2} correlates very well with real-scale fire behavior for which propagation is limited to the ignition zone.

X1.7 Examples of Materials That Have Undergone the Test Methods

X1.7.1 A wide range of polymeric materials and products

^APolymer abbreviations: PVC—polyvinylchloride; PVDF—polyvinylidene fluoride; FRPP—fire retarded polypropylene; ETFE—ethylenetetrafluoroethylene; PMMA—polymethylmethacrylate; XLPE—crosslinked polyethylene; XLPO—crosslinked polyolefin; EVA—ethylvinyl acetate; PE—polyethylene; CR—chloroprene rubber; SBR—styrene-butadiene rubber.

^BPropagation Behavior: Yes—fire propagates beyond the ignition zone to the boundary of the exposed material surface; Limited—fire propagates beyond the ignition zone but propagation stops well before the boundary of the exposed material surface; None—fire does not propagate beyond the ignition zone, defined as the area of flame coverage by the initiating fire source.

have undergone the Ignition, Combustion, or Fire Propagation test methods, in addition to the polymers noted in X1.6.2. Table

X1.3, extracted from Tables 3–4.2, 3–4.3 and 3–4.11 in Ref (4) and Table 1 in Ref (7), lists these polymer groups.

X1.7.2 The Ignition and Combustion test methods, as well as other tests performed in the FPA, have been used to obtain flammability characteristics of plywood specimens for use in a predictive model of upward fire propagation, as described in Ref (13). Predictions from the computer model were in good agreement with the results of real-scale fire tests of vertical panels of the same plywood materials.

X1.8 Precision

X1.8.1 Table X1.4 presents data on precision, based on a comparison of results from the Ignition Test method performed at two separate laboratories of Factory Mutual Research Corporation. Table X1.5 presents data on precision, based on a comparison of results from the Fire Propagation test method

TABLE X1.3 Examples of Materials That Have Undergone the Test Methods

Description of Polymer or Material Containing Polymer	Parameters Calculated
Polystyrene	TRP, EHC
Polypropylene	TRP, EHC
Polyoxymethylene	TRP, EHC
Nylon	TRP, EHC
Polycarbonate	TRP, EHC
Fiberglass-reinforced polyester	TRP, FPI, EHC
Fiberglass-reinforced epoxy	TRP, FPI, EHC
Fluorinated ethylene-propylene	TRP, FPI, EHC
Phenolic/kevlar composite	TRP, FPI, EHC
Polyurethane foams	TRP, EHC
Polystyrene foams	TRP, EHC
Phenolic foams	TRP, EHC
Wood, cardboard containing cellulose	TRP, FPI, EHC

TABLE X1.4 Reproducibility of Data on Ignition Time

Polymer-Insulated Cable Type	Incident Heat Flux	Time to Ignition, Apparatus 1	Time to Ignition, Apparatus 2	Relative Difference of Each Ignition Time from the Mean Value
	[kW/m ²]	[s]	[s]	[%]
Insulated cable 1	20	265	260	1
Insulated cable 1	30	91	102	5.7
Insulated cable 1	40	45	58	12.6
Insulated cable 1	50	34	36	2.9
Insulated cable 1	60	21	24	6.7
Insulated cable 2	15	334	320	2.1
Insulated cable 2	30	42	41	1.2
Insulated cable 2	40	24	24	0
Insulated cable 2	50	17	17	0
Insulated cable 2	60	13	11	8.3

TABLE X1.5 Reproducibility of Data on Heat Release Rate

Specimen Type	Peak Heat Release Rate, Apparatus 1	Peak Heat Release Rate, Apparatus 2	Relative Difference of Each Heat Release Rate from the Mean Value
	[kW]	[kW]	[%]
Insulated cable 1	7	6	7.7
Insulated cable 2	5.6	5.2	3.7
Insulated cable 3	8	7.5	3.2
Conveyor belt 1	13.4	10.8	10.7
Conveyor belt 2	9.25	9.05	1.1

with an inlet air supply containing 40 % oxygen, performed at the same two laboratories.

REFERENCES

- (1) Cable Fire Propagation Specification Test Standard, Class Number 3972, Factory Mutual Research Corporation, Norwood, MA 02062–9102, July 1989.
- (2) *Clean Room Materials Flammability Test Protocol: Test Standard, Class Number 4910*, Factory Mutual Research Corporation, Norwood, MA 02062–9102, September 1997.
- (3) *Class 1 Conveyor Belting Approval Standard, Class Number 4998*, Factory Mutual Research Corporation, Norwood, MA 02062–9102, August 1995.
- (4) Tewarson, A., “Generation of Heat and Chemical Compounds in Fires,” Chapter 4, Section 3, *The SFPE Handbook of Fire Protection Engineering*, 2nd Edition, pp. 3–53 to 3–84, The National Fire Protection Association Press, Quincy, MA, June 1995.
- (5) Tewarson, A. and Ogden, S.D., “Fire Behavior of Polymethylmethacrylate,” *Combustion and Flame*, Vol. 89, pp. 237–259, 1992.
- (6) Ackeret, J., “Aspects of Internal Flow,” in *Fluid Mechanics of Internal Flow* (G. Sovran, ed.), Elsevier Publishing Company, New York, p. 1, 1967.
- (7) Tewarson, A. and Khan, M.M., “Flame Propagation for Polymers in Cylindrical Configuration and Vertical Orientation,” *Twenty-Second Symposium (International) on Combustion*, p. 1231–40, The Combustion Institute, Pittsburgh, PA 1988.
- (8) Tewarson, A. and Khan, M.M., “Fire Propagation Behavior of Electrical Cables,” *Fire Safety Science—Proceedings of the Second International Symposium*, International Association for Fire Safety Science, pp. 791–800, Hemisphere Publishing Corporation, New York 1989.
- (9) Tewarson, A. and Newman, J.S., “Scale Effects on Fire Properties of Materials,” *Fire Safety Science—Proceedings of the First International Symposium*, International Association for Fire Safety Science, pp. 451–462, Hemisphere Publishing Corporation, New York 1986.
- (10) Tewarson, A., Lee, J.L., and Pion, R.F., “The Influence of Oxygen Concentration on Fuel Parameters for Fire Modeling,” *Eighteenth Symposium (International) on Combustion*, pp. 563–570, The Combustion Institute, Pittsburgh, PA 1981.
- (11) Tewarson, A., Bill, R.G. Jr., Braga, A., DeGiorgio, V. and Smith, G., “Flammability of Clean Room Materials,” Factory Mutual Research Corporation, White Paper, FMRC J.I. 0B0J8.RC, November, 1996.
- (12) Lazzara, C.P. and Perzak, F.J., “Conveyor Belt Flammability Test: Comparison of Large-Scale Gallery and Laboratory-Scale Tunnel Results,” *Proceedings of 23rd International Conference of Safety in Mines*, Mines Research Institute, Washington, DC, Sept. 11–15, 1989, pp. 138–150.
- (13) Tewarson, A., “Flammability,” Chapter 42 in *Physical Properties of Polymers Handbook*, J.E. Mark, Ed., The American Institute of Physics, Woodbury, New York, pp. 577–604, 1996.
- (14) Delichatsios, M.M., Wu, P., Delichatsios, M.A., Lougheed, G.D., Crampton, G.P., Qian, C., Ishida, H. and Saito, K., “Effect of External Radiant Heat Flux on Upward Fire Spread: Measurements on Plywood and Numerical Predictions,” *Fire Safety Science—Proceedings of the Fourth International Symposium*, International Association for Fire Safety Science, pp. 421–432, 1994.

 **E 2058**

The American Society for Testing and Materials takes no position respecting the validity of any patent rights asserted in connection with any item mentioned in this standard. Users of this standard are expressly advised that determination of the validity of any such patent rights, and the risk of infringement of such rights, are entirely their own responsibility.

This standard is subject to revision at any time by the responsible technical committee and must be reviewed every five years and if not revised, either reapproved or withdrawn. Your comments are invited either for revision of this standard or for additional standards and should be addressed to ASTM Headquarters. Your comments will receive careful consideration at a meeting of the responsible technical committee, which you may attend. If you feel that your comments have not received a fair hearing you should make your views known to the ASTM Committee on Standards, at the address shown below.

This standard is copyrighted by ASTM, 100 Barr Harbor Drive, PO Box C700, West Conshohocken, PA 19428-2959, United States. Individual reprints (single or multiple copies) of this standard may be obtained by contacting ASTM at the above address or at 610-832-9585 (phone), 610-832-9555 (fax), or service@astm.org (e-mail); or through the ASTM website (www.astm.org).