



Designation: E 2067 – 02

## Standard Practice for Full-Scale Oxygen Consumption Calorimetry Fire Tests<sup>1</sup>

This standard is issued under the fixed designation E 2067; the number immediately following the designation indicates the year of original adoption or, in the case of revision, the year of last revision. A number in parentheses indicates the year of last reapproval. A superscript epsilon ( $\epsilon$ ) indicates an editorial change since the last revision or reapproval.

### 1. Scope

1.1 This practice deals with methods to construct, calibrate, and use full scale oxygen consumption calorimeters to help minimize testing result discrepancies between laboratories.

1.2 The methodology described herein is used in a number of ASTM test methods, in a variety of unstandardized test methods, and for research purposes. This practice will facilitate coordination of generic requirements, which are not specific to the item under test.

1.3 The principal fire-test-response characteristics obtained from the test methods using this technique are those associated with heat release from the specimens tested, as a function of time. Other fire-test-response characteristics also are determined.

1.4 This practice is intended to apply to the conduction of different types of tests, including both some in which the objective is to assess the comparative fire performance of products releasing low amounts of heat or smoke and some in which the objective is to assess whether flashover will occur.

1.5 This practice does not provide pass/fail criteria that can be used as a regulatory tool, nor does it describe a test method for any material or product.

1.6 For use of the SI system of units in referee decisions, see IEEE/ASTM SI-10. The units given in parentheses are provided for information only.

1.7 This standard is used to measure and describe the response of materials, products, or assemblies to heat and flame under controlled conditions, but does not by itself incorporate all factors required for fire hazard or fire risk assessment of the materials, products, or assemblies under actual fire conditions.

NOTE 1—This is the standard caveat described in section F2.2.2.1 of the Form and Style for ASTM Standards manual for fire-test-response standards. In actual fact, this practice does not provide quantitative measures.

1.8 Fire testing of products and materials is inherently hazardous, and adequate safeguards for personnel and property shall be employed in conducting these tests. Fire testing involves hazardous materials, operations, and equipment. See also Section 7.

<sup>1</sup> This practice is under the jurisdiction of ASTM Committee E05 on Fire Standards and is the direct responsibility of Subcommittee E05.13 on Large Scale Fire Tests.

Current edition approved Sept. 10, 2002. Published November 2002. Originally published as E 2067–00. Last previous edition E 2067–00a.

1.9 *This standard does not purport to address all of the safety concerns, if any, associated with its use. It is the responsibility of the user of this standard to establish appropriate safety and health practices and determine the applicability of regulatory limitations prior to use.*

### 2. Referenced Documents

#### 2.1 ASTM Standards:

- D 5424 Test Method for Smoke Obscuration of Insulating Materials Contained in Electrical or Optical Fiber Cables When Burning in a Vertical Cable Tray Configuration<sup>2</sup>
- D 5537 Test Method for Heat Release, Flame Spread and Mass Loss Testing of Insulating Materials Contained in Electrical or Optical Fiber Cables When Burning in a Vertical Cable Tray Configuration<sup>2</sup>
- D 6113 Test Method for Using a Cone Calorimeter to Determine Fire-Test-Response Characteristics of Insulating Materials Contained in Electrical or Optical Fiber Cables<sup>2</sup>
- E 84 Test Method for Surface Burning Characteristics of Building Materials<sup>3</sup>
- E 176 Terminology of Fire Standards<sup>3</sup>
- E 603 Guide for Room Fire Experiments<sup>3</sup>
- E 662 Test Method for Specific Optical Density of Smoke Generated by Solid Materials<sup>3</sup>
- E 906 Test Method for Heat and Visible Smoke Release Rates for Materials and Products<sup>3</sup>
- E 1354 Test Method for Heat and Visible Smoke Release Rates for Materials and Products Using an Oxygen Consumption Calorimeter<sup>3</sup>
- E 1474 Test Method for Determining the Heat Release Rate of Upholstered Furniture and Mattress Components or Composites Using a Bench Scale Oxygen Consumption Calorimeter<sup>3</sup>
- E 1537 Test Method for Fire Testing of Upholstered Furniture<sup>3</sup>
- E 1590 Test Method for Fire Testing of Mattresses<sup>3</sup>
- E 1623 Test Method for Determination of Fire and Thermal Parameters of Materials, Products and Systems Using an Intermediate Scale Calorimeter (ICAL)<sup>3</sup>
- E 1740 Test Method for Determining the Heat Release Rate

<sup>2</sup> Annual Book of ASTM Standards, Vol 10.02.

<sup>3</sup> Annual Book of ASTM Standards, Vol 04.07.

and Other Fire-Test-Response Characteristics of Wallcovering Composites Using a Cone Calorimeter<sup>3</sup>

IEEE/ASTM SI-10, International System of Units (SI) The Modernized Metric System<sup>4</sup>

2.2 *ISO Standards:*<sup>5</sup>

ISO Guide 52 - Glossary of Fire Terms and Definitions

ISO 3261 Fire Tests - Vocabulary

ISO 5660-1, Fire Tests—Reaction to Fire—Rate of Heat Release from Building Products (Cone Calorimeter Method)

ISO 9705, Fire Tests - Full-Scale Room Test for Surface Products

2.3 *California Bureau of Home Furnishings and Thermal Insulation Standards:*<sup>6</sup>

CA Technical Bulletin 129 (October 1992), Flammability Test Procedure for Mattresses for Use in Public Buildings

CA Technical Bulletin 133 (January 1991), Flammability Test Procedure for Seating Furniture for Use in Public Occupancies

2.4 *NFPA Standards:*<sup>7</sup>

NFPA 265 Standard Methods of Fire Tests for Evaluating Room Fire Growth Contribution of Textile Wall Coverings

NFPA 266 Standard Method of Test for Fire Characteristics of Upholstered Furniture Exposed to Flaming Ignition Source

NFPA 267 Standard Method of Test for Fire Characteristics of Mattresses and Bedding Assemblies Exposed to Flaming Ignition Source

NFPA 286 Standard Methods of Fire Tests for Evaluating Room Fire Growth Contribution of Wall and Ceiling Interior Finish

2.5 *UL Standards:*<sup>8</sup>

UL 1685, Standard Vertical Tray Fire Propagation and Smoke Release Test for Electrical and Optical Fiber Cables

UL 1975, Standard Fire Tests for Foamed Plastics Used for Decorative Purposes

### 3. Terminology

3.1 *Definitions*—For definitions of terms used in this practice, refer to Terminology E 176 and ISO 3261. In case of conflict, the definitions given in Terminology E 176 shall prevail.

3.1.1 *heat release rate, n*—the heat evolved from the specimen, per unit of time. **(E 176)**

3.1.2 *ignition, n*—the initiation of combustion. **(E 176)**

3.1.2.1 *Discussion*—The combustion may be evidenced by glow, flame, detonation or explosion. The combustion may be sustained or transient.

3.1.3 *oxygen consumption principle, n*—the expression of the relationship between the mass of oxygen consumed during combustion and the heat released. **(E 176)**

3.1.4 *smoke, n*—the airborne solid and liquid particulates and gases evolved when a material undergoes pyrolysis or combustion. **(E 176)**

3.1.5 *smoke obscuration, n*—reduction of light transmission by smoke, as measured by light attenuation. **(E 176)**

3.2 *Definitions of Terms Specific to This Standard:*

3.2.1 *composite, n*—a combination of materials, which generally are recognized as distinct entities, for example, coated or laminated materials.

3.2.2 *continuous (as related to data acquisition), adj*—conducted at data collection intervals of 6 s or less.

3.2.3 *sample, n*—an amount of the material, product, or assembly, to be tested, which is representative of the item as a whole.

3.2.4 *specimen, n*—representative piece of the product, which is to be tested together with any substrate or treatment.

### 4. Significance and Use

4.1 The oxygen consumption principle, used for the measurements described here, is based on the observation that, generally, the net heat of combustion is directly related to the amount of oxygen required for combustion (1).<sup>9</sup> Approximately 13.1 MJ of heat are released per 1-kg of oxygen consumed. Test specimens in the test are burned in ambient air conditions, while being subjected to a prescribed external heating source.

4.1.1 This technique is not appropriate for use on its own when the combustible fuel is an oxidizer or an explosive agent, which release oxygen. Further analysis is required in such cases (see Appendix X2).

4.2 The heat release is determined by the measurement of the oxygen consumption, as determined by the oxygen concentration and the flow rate in the combustion product stream, in a full scale environment.

4.3 The primary measurements are oxygen concentration and exhaust gas flow rate. Additional measurements include the specimen ignitability, the smoke obscuration generated, the specimen mass loss rate, the effective heat of combustion and the yields of combustion products from the test specimen.

4.4 The oxygen consumption technique is used in different types of test methods. Intermediate scale (Test Method E 1623, UL 1975) and full scale (Test Method D 5424, Test Method D 5537, Test Method E 1537, Test Method E 1590, Test Method E 1822, ISO 9705, NFPA 265, NFPA 266, NFPA 267, NFPA 286, UL 1685) test methods, as well as unstandardized room scale experiments following Guide E 603, using this technique involve a large instrumented exhaust hood, where oxygen concentration is measured, either standing alone or positioned outside a doorway. A large test specimen is placed either under the hood or inside the room. This practice is intended to address issues associated with equipment requiring a large instrumented hood and not stand-alone test apparatuses with small test specimens.

<sup>9</sup> The boldface numbers in parentheses refers to the list of references at the end of this standard.

<sup>4</sup> Annual Book of ASTM Standards, Vol 14.02.

<sup>5</sup> Available from International Standardization Organization, P.O. Box 56, CH-1211; Geneva 20, Switzerland.

<sup>6</sup> Available from California Bureau of Home Furnishings and Thermal Insulation, State of California, Department of Consumer Affairs, 3485 Orange Grove Avenue, North Highlands, CA 95660-5595.

<sup>7</sup> Available from National Fire Protection Association (NFPA), 1 Batterymarch Park, Quincy, MA 02269-9101.

<sup>8</sup> Available from Underwriters Laboratories (UL), Corporate Progress, 333 Pfingsten Rd., Northbrook, IL 60062.

4.4.1 Small scale test methods using this technique, such as Test Methods D 6113, E 1354, E 1474 and E 1740, as well as, ISO 5660 internationally, are based on a stand-alone apparatus, wherein a small specimen is tested within the equipment.

4.5 Throughout this practice, test equipment is referenced to provide helpful guidance to test facilities. Substitution of equivalent, or better, test measuring devices is permissible.

## 5. Test Room Layout

### 5.1 Standard Rooms:

5.1.1 Three standard room configurations have been in common use for many years, often designated as the “ASTM”/“ISO” room (cited in Guide E 603 and in ISO 9705), and the “California” room (used in CA TB 129 and CA TB 133, as well as, Test Methods E 1537, E 1590, and E 1822), and the cable tray test room (used in Test Methods D 5424 and D 5537, as well as, in UL 1685).

5.1.2 *ASTM/ISO Room*—The test room shall have interior dimensions of 2.44 m ± 25 mm by 3.66 m ± 25 mm by 2.44 m ± 25 mm high (8 by 12 by 8 ft high). The room shall have no openings other than a doorway opening 0.76 m ± 6 mm by 2.03 m ± 6 mm (30 by 80 in.), located as indicated in Fig. 1, and other small openings, as necessary to make test measurements. Construct the test room of wooden or metal studs, and line it with gypsum wallboard, Type X, or calcium silicate wallboard. Position a hood (see Section 6) outside of the room doorway, such that it collects all the combustion gases. There shall be no obstructions to the air supply to the test setup.

NOTE 2—Both Type X gypsum wallboard and calcium silicate wallboard with a thickness of 12.7 mm (0.5 in.) have been found acceptable.

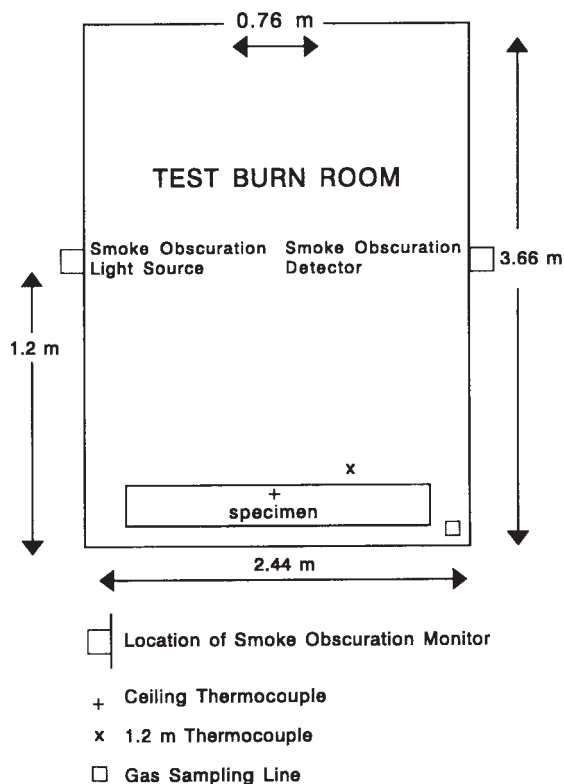

NOTE 1—See text for tolerances; room instrumentation is optional.  
**FIG. 1 Test Room Configuration A (ASTM room)**

If the wallboard is thicker, it will not affect the results of this test. Gypsum wallboard is likely to generate a measurable amount of heat or smoke release at high heat inputs, due primarily to its paper facer.

5.1.2.1 Install an additional layer of fire rated wallboard on the portions of the walls or ceiling directly adjacent to the test specimen location. Cover at least 1.22 by 1.22 m (4 by 4 ft) of the ceiling with the added wallboard, but do not place an additional layer of wallboard under the test specimen. This ceiling surface is the most severely exposed to flames and heat and needs frequent replacement. Replace any portion of the lining if cracks occur or severe burn damage is observed.

5.1.2.2 Frequently, whenever there is a single test specimen, such as Test Method E 1537, Test Method E 1590, or Test Method E 1822, the test specimen location is the corner of the room furthest away from the doorway. The test specimen also is usually placed on a weighing platform. This test room is unsuitable for Test Method D 5424 or Test Method D 5537. The test method indicates test specimen location.

5.1.2.3 When testing surface linings (walls or ceilings), weighing of the test specimen during the test is usually not practical. Mass loss during testing, if desired, must be estimated from calculations.

5.1.3 *California Room*—The test room shall have dimensions of 3.05 m ± 25 mm × 3.66 m ± 25 mm × 2.44 m ± 25 mm high (10 by 12 by 8 ft high). The room shall have no openings other than a doorway opening 0.97 m ± 6 mm × 2.06 m ± 6 mm (38 by 81 in.), located as indicated in Fig. 2, and other small openings, as necessary to make test measurements. Construct the test room of wooden or metal studs, and line it

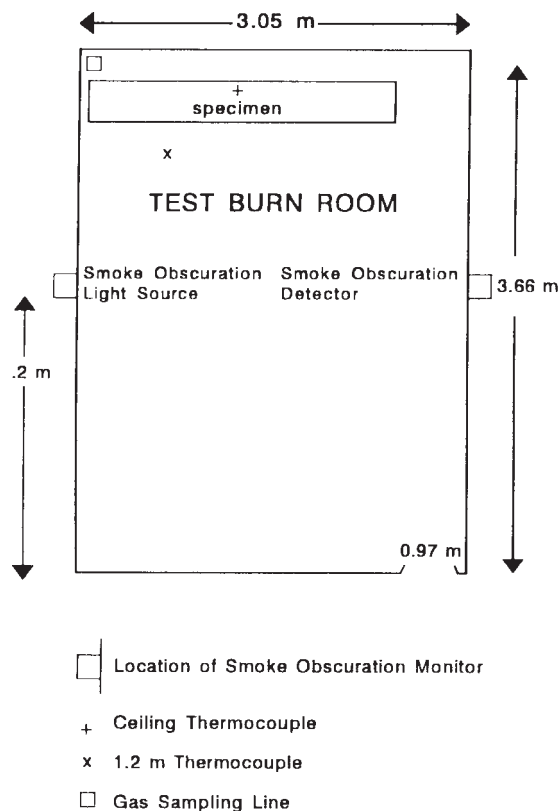

NOTE 1—See text for tolerances; room instrumentation is optional.  
**FIG. 2 Test Room Configuration B (CA Room)**

with gypsum wallboard, Type X, or calcium silicate wallboard. Position a hood (see Section 6) outside of the room doorway, such that it collects all the combustion gases. There shall be no obstructions to the air supply to the test set-up.

NOTE 3—Both Type X gypsum wallboard and calcium silicate wallboard with a thickness of 12.7 mm (0.5 in.) have been found acceptable. If the wallboard is thicker, it will not affect the results of this test. Gypsum wallboard likely is to generate a measurable amount of heat or smoke release at high heat inputs, due primarily to its paper facer.

5.1.3.1 Install an additional layer of fire rated wallboard on the portions of the walls or ceiling directly adjacent to the test specimen location. Cover at least 1.22 by 1.22 m (4 by 4 ft) of the ceiling with the added wallboard, but do not place an additional layer of wallboard under the test specimen. This ceiling surface is the most severely exposed to flames and heat and needs frequent replacement. Replace any portion of the lining if cracks occur or severe burn damage is observed.

5.1.3.2 This test room commonly is used for furniture testing only. Usually, the test specimen is located in a corner and placed on a weighing platform. This test room is unsuitable for Test Methods D 5424 or D 5537. The test method indicates test specimen location.

5.1.3.3 When testing surface linings (walls or ceilings), weighing of the test specimen during the test is usually not practical. Mass loss during testing, if desired, must be estimated from calculations.

5.1.4 Cable Tray Test Room:

5.1.4.1 The test room shall have floor dimensions of 2.44 m ± 25 mm by 2.44 m ± 25 mm, with a height of 3.35 m ± 25 mm (8 ft ± 1 in. by 8 ft ± 1 in. by 11 ft ± 1 in. high). On top of the walls there shall be a pyramidal collection hood (see Section 6 for exhaust system information), with a collection box. The walls shall have a maximum conductive heat flux loss of 6.8 W/(m<sup>2</sup>K) (30 Btu/h-ft<sup>2</sup>), based upon an inside wall temperature of 38°C (100°F) and an outside air temperature of 24°C (75°F), and the interior surface of the walls shall be painted flat black.

5.1.4.2 Any materials of construction that meet the above requirements are acceptable. Two examples of acceptable construction materials are nominally 152-mm (6-in.) thick concrete masonry blocks (density: 1700 kg m<sup>-3</sup> (106 lb ft<sup>-3</sup>) and thermal conductivity nominally  $k = 1.75 \text{ W/(m K)}$ , at 21°C; 12.13 Btu in./ft<sup>2</sup> h °F, at 70°F) or nominally 13 mm (0.5 in.) gypsum board, with 89 ± 6 mm (3.5 ± 0.25 in.) of standard fiberglass insulation, with an  $R$  value of 1.94 m<sup>2</sup> K/W (which corresponds in practical units to an  $R$  value of 11 h ft<sup>2</sup> °F/Btu). Windows for observation of the fire test are allowed in the walls; ensure that the total area of the windows does not exceed 1.86 m<sup>2</sup> (20 ft<sup>2</sup>).

5.1.4.3 Select materials of construction which withstand the high temperatures and presence of open flame within the test enclosure and duct. An acceptable construction consists of concrete masonry blocks nominally 203 mm high by 406 mm wide by 152 mm thick (8 by 16 by 6 in.).

5.1.4.4 Provide air intakes at the base of two opposite walls, one of which contains the access door. Ensure that the total cross sectional area of the air intakes is 1.45 ± 0.03 m<sup>2</sup> (2250 ± 50 in.<sup>2</sup>), and that the intake areas are divided approximately

equal. The air intakes are 559 mm by 343 mm high (22 by 13.5 in.) either side of the door, 914 mm by 343 mm high (36 by 13.5 in.) under the door, and the entire back wall length, with a height of 305 mm (12 in.). Air intakes are not permitted in either of the other two walls.

5.1.4.5 The door shall be constructed with wired glass, and shall measure 900 ± 25 mm wide and 2100 ± 25 mm high (35 ± 1 in. by 83 ± 1 in.), with an overall conductive heat flux loss no greater than that of the walls, that is, 6.8 W/(m<sup>2</sup> K) (30 Btu/h-ft<sup>2</sup>). A steel-framed wired glass door will meet these requirements. Adequately seal the sides and top of the door to prevent drafts.

5.1.4.6 Construct a truncated pyramid stainless steel hood, formed as shown in Fig. 3, and locate it on top of the enclosure walls. Make the slope on each side of the hood 40°. Form a seal between the hood and the walls; a compressible inorganic batting as gasket is suitable. Insulate the exterior of the hood to make an overall conductive heat loss no greater than that of the walls. Locate a cubical stainless steel collection box, 910 ± 25 mm (36 ± 1 in.), on a side on top of the exhaust hood, with a nominal 410 ± 25-mm (16 ± 1-in.) diameter stainless steel pipe exhaust duct centered in one side.

5.2 Nonstandard Rooms:

5.2.1 Standardized tests also are conducted in rooms of somewhat different dimensions than the ASTM or California rooms, after the attainment of equivalent results has been demonstrated.

5.2.2 Nonstandardized tests and research experiments are conducted in rooms of different sizes. The compartment size, shape, and openings shall be chosen to simulate the nature or type of compartment or facility in which the subject material, product, or system is expected to be used in actual service. If there is a range of sizes, then account shall be taken of the fact that for a given ignition exposure, the smaller compartment sizes usually will provide the most severe fire development conditions. Whenever possible, a compartment shall be designed to be symmetrical and as simple as possible for ease of analysis. Space between the top of door and the ceiling is critical because of the trapping of the smoke and hot gases. The room shall be located inside a larger, carefully ventilated

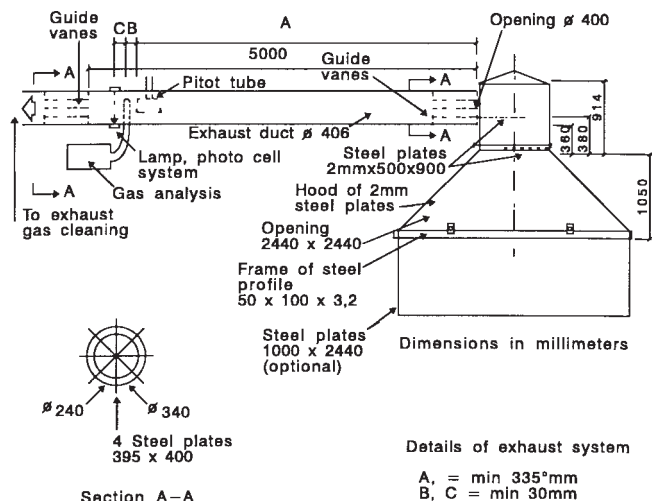

**FIG. 3 Design of Hood and Exhaust System**



enclosure to ensure minimum interference from drafts or wind currents.

5.2.3 Follow the guidelines of 5.1.2 or 5.1.4 for the construction materials, depending on the application. Be especially mindful of the use of additional fire rated wallboard if test specimens are placed near walls or ceilings.

#### 5.3 Furniture Calorimeter (Open Calorimeter):

5.3.1 This type of testing is appropriate for intermediate scale test methods, such as Test Method E 1623, and for testing individual products, such as items of furniture, or relatively large constructions, such as foam displays (UL 1975). Position the test specimen centrally on a weighing platform, which shall be located centrally under the collection hood.

5.3.2 The test enclosure that houses the exhaust hood shall be of sufficiently large dimensions that there are no spurious heat radiation effects from the walls or any other nearby objects. The air flow to the test specimen shall be symmetrical from all sides. The hood is located directly above the test specimen (see Section 6).

#### 5.4 Enclosure Room:

5.4.1 Any test room, as well as any furniture calorimeter, together with the corresponding hood and exhaust duct system, shall be positioned in a large enclosed room. The enclosure area shall be constructed of fire resistant materials, such as concrete, for walls and ceiling, and it shall be completely isolated from neighboring rooms and facilities. The walls of the enclosure shall be far enough away from the walls of the test room for the enclosure room to be ventilated adequately. The height of the ceiling shall be sufficient to allow for installation of the exhaust duct and easy access to the heat release calorimetry and other instrumentation.

5.4.1.1 It is important that during each test a free and sufficient flow of make-up air be available to facilitate the combustion process, without creating any forced flow of air into or out of the test room. The combination of exhaust hood and enclosure room shall be sufficiently large to achieve this objective.

5.4.1.2 Distances of at least 6 m (20 ft) between the enclosure walls and the walls of the test room and a minimum height of 4.6 m (15 ft) are recommended, as minimum requirements; larger enclosure rooms are even more desirable since they will minimize any effects of the enclosure walls on the test conditions. Such effects include radiative feedback from the heated walls and obstruction of air supply into the room. A larger enclosure also will provide easier access to all sides of the test room and instrumentation during the tests, and in case of an emergency, and for routine repairs and maintenance. See 11.2.14 for information regarding smaller enclosure rooms.

5.4.2 The enclosure shall allow for sufficient supply of fresh air into the test room during tests and shall not create any obstructions to the ambient air supply. Openings in the enclosure shall not be situated in a way that would create any forced convective air flows inside the test room, and thus, affecting the burning of the test specimen.

5.4.3 When using an open (furniture) calorimeter, it is recommended that a minimum distance of 6 m (20 ft) be

maintained between enclosure walls and the test specimen in all directions.

## 6. Hood and Exhaust Collection System

6.1 The exhaust collection system shall consist of a blower, steel hood, duct, bidirectional probe, thermocouple(s), oxygen measurement system, smoke obscuration measuring system (white light or laser), and combustion gas sampling and analysis system.

6.1.1 The system for collecting the combustion products shall have a capacity and be designed in such a way that all of the combustion products leaving the burning specimen are collected. Design the capacity of the evacuation system so as to exhaust and collect all combustion gases leaving the burning test specimen without excessive make-up air.

6.2 Place probes for sampling of combustion gas and for measurement of flow rate in accordance with 6.3. Measure all combustion product (smoke obscuration and gas concentrations) at a position in the exhaust duct where the exhaust is uniformly mixed and there is a nearly uniform velocity across the duct section. A distance of 8 to 30 duct diameters is satisfactory for this purpose.

6.3 *Instrumentation in Exhaust Duct*—Further details are set out in Section 7.

6.3.1 *Flow Rate*—Measure the flow rate in the exhaust duct by means of a bidirectional probe located at the center line of the duct. Measure the flow rate in the exhaust duct with an accuracy of at least  $\pm 10\%$ . The response time to a stepwise change of the duct flow rate shall be a maximum of 6 s to reach 90 % of the final value.

#### 6.3.2 Combustion Gas Analysis:

6.3.2.1 *Sampling Line*—Make the sampling line tubes of a material not influencing the concentration of the combustion gas species to be analyzed. See 7.1 for the sequence of the gas train.

6.3.2.2 *Oxygen Measurement*—Measure the oxygen concentration with an accuracy of at least  $\pm 0.04\%$  of full scale in the output range of 0 to 21 volume % oxygen, or  $\pm 0.01$  volume % oxygen, in order to have adequate measurements of rate of heat release. Take the combustion gas sample from the end of the sampling line. Calculate the time delay, including the time constant of the instrument, from the test room, which is a function of the exhaust duct flow rate. It shall be no more than 30 s.

6.3.2.3 *Carbon Monoxide and Carbon Dioxide Measurement*—Measure the combustion gas species with an instrument having an accuracy of at least  $\pm 0.1$  volume % for carbon dioxide and  $\pm 0.02$  volume % for carbon monoxide. A suitable output range is 0 to 1 volume % for carbon monoxide and 0 to 6 volume % for carbon dioxide. Take the combustion gas sample from the end of the sampling line. Calculate the time delay, including the time constant of the instrument, from the test room; it is a function of the exhaust duct flow rate. It shall be a maximum of 30 s.

6.3.2.4 *Smoke Obscuration Measurement*—Install an optical system for measurement of light obscuration across the centerline of the exhaust duct. Determine the optical density of the smoke by measuring the light transmitted with a photometer system consisting of a lamp, plano convex lenses, an

aperture, a photocell, and an appropriate power supply. Construct the system so that soot deposits on the optics during a test do not reduce the light transmission by more than 5 %. Alternatively, instrumentation using a laser beam system, with an 0.5 to 2.0 mW helium-neon laser, instead of white light system is also acceptable. It has been shown that white light and laser systems will give similar results (2-6).

**6.4 Example Design of a Satisfactory Collection Hood and Exhaust Duct**—The system described has been tested in practice and proven to fulfill the requirements (7-8).

**6.4.1** The hood is located just outside the room doorway. Its bottom dimensions are 2.4 by 2.4 m (8 by 8 ft) and the height is 1.0 m (3.3 ft). On all four sides steel sheets are extended 1.0 m (3.3 ft) downwards, making the effective height of the hood 2.0 m (6.6 ft). The distance between the lower edge of the hood and the floor (or the weighing platform when using a furniture calorimeter) shall be 1.8–2.0 m (6.0–6.4 ft). The hood feeds into a plenum having a 0.9 by 0.9 m (3 by 3 ft) cross-sectional area, and a height of 0.9 m (3 ft). The maximum acceptable height of this plenum area is 1.8 m (6 ft), depending on building constraints. In the plenum chamber two baffle (usually steel) plates approximately 0.5 by 0.9 m (1.6 by 3.0 ft) are located to increase mixing of the combustion gases. The hood shall be designed and manufactured so that no spill-over occurs.

**6.4.2** The exhaust duct shall be connected with the plenum chamber. The inner diameter of the exhaust duct shall be in the range 400–760 mm (16–30 in.). To facilitate flow measurements, guide vanes, if needed, are located at both ends of the exhaust duct. Alternatively, the rectilinear part of the exhaust duct shall have such a length that a fully-developed flow profile is established at the point of measurement.

**6.4.2.1** The exhaust duct shall be connected to an evacuation system. The capacity of the evacuation system shall be designed to exhaust all combustion gases leaving the specimen. This requires an exhaust capacity of at least  $2.7 \text{ kg s}^{-1}$  (about  $8000 \text{ m}^3 \text{ h}^{-1}$  at standard atmospheric conditions) corresponding to a driving under pressure of about 2 kPa at the end of the duct. A variable speed exhaust fan with a DC motor drive is suitable for this use. Alternatively, an adjustable frequency controller also is suitable, in conjunction with a single speed exhaust fan.

**6.4.2.2** The controller generates an adjustable voltage/frequency output for complete control of the conventional induction motor that runs the exhaust fan. The system allows for control of the exhaust flow rate from zero to the maximum capacity of the fan by adjusting the speed of the motor. It shall be possible to control the exhaust flow from about  $0.5 \text{ kg s}^{-1}$  up to maximum flow during the test process.

**6.4.3** The system shall be capable of measuring rates of heat release with sufficient accuracy (at least 6 %).

**6.4.4** When the objective of the tests is to perform comparisons between products expected to release low amounts of heat or smoke, the system shall still be capable of measuring low rates of heat release (such as 10 kW) with sufficient accuracy (at least 6 %). If concentration gradients are found to exist, mixing vanes are an adequate means of addressing the problem.

**NOTE 4**—It is likely that a single system will not have the same degree of accuracy of heat release rate measurements over a range of heat release rates as high as 1 MW and as low as 10 kW. Tests designed to assess whether flashover will occur, such as NFPA 265, NFPA 286, or ISO 9705, require measurements as high as 1 MW, while tests designed to assess the suitability of single products, such as Test Methods E 1537 and E 1590 or UL 1975, require accurate measurements of at levels of < 100 kW; thus, measurement accuracy must be a function of test requirements.

**6.4.5** Use of an alternative exhaust system design is limited to those systems shown to produce equivalent results. Equivalency is demonstrated by meeting the calibration requirements. Exhaust system designs based on natural convection are not permitted.

**6.4.6** When using an open calorimeter the hood shall be installed above the mass measuring system and test specimen. The distance between the lower edge of the hood and the mass measuring system shall range between 1.8 and 3.0 m (6 to 10 ft). The hood shall be designed and manufactured such that no spill-over occurs and all the smoke is collected.

**NOTE 5**—If hoods are too large, potential resulting problems are excessive air entrainment, deposition on cold surfaces, or dilution of smoke.

**6.4.7** Leakage of combustion products is detectable visually during burn tests. Visually observe the collection of gases and smoke through the exhaust duct. If any smoke escapes into the surroundings, even at high exhaust flow rates, use a skirt capable of withstanding the high temperatures, about 1 m (3 ft) wide, to hang around the lower edges of the exhaust hood as a curtain. This curtain will assist in guiding more of the combustion products into the exhaust hood. Note that, if such a curtain is used during burn tests, all system calibrations also shall have been conducted with this curtain in place.

**6.5** If pollution abatement equipment is present, the exhaust removal system shall still be capable of fulfilling the requirements of the test method throughout the entire test, without affecting the results. If the system affects test results, such results as are obtained after the effect of the abatement equipment come into effect are invalid.

## **7. Exhaust Duct Instrumentation**

**7.1** A gas analysis system is required to make measurements of oxygen (for determining heat release), and other gaseous species, such as carbon monoxide, carbon dioxide and any other species of interest, in the exhaust duct. The sequence of the gas train shall be sampling probe, soot filter, cold trap, gas path pump, vent valve, plastic drying column and carbon dioxide removal columns (if used), flow controller, and oxygen analyzer. The gas train also shall include appropriate spanning and zeroing facilities. Other designs are acceptable if equivalency has been demonstrated.

**7.2** To install the instruments in the duct, and for maintenance purposes, one or more access doors shall be provided in the exhaust duct. These exhaust duct doors shall be sealed tightly during testing.<sup>10</sup>

### **7.3 Gas Sampling Probe:**

**7.3.1** The gas sampling probe shall be located in a position where the exhaust duct flow is well mixed (turbulent flow).

<sup>10</sup> High-temperature silicone rubber sealant is suitable for this purpose.

Install the gas sampling probe at a distance of at least eight duct diameters downstream of the last turn from the exhaust hood. If the minimum straight section before the measuring system is at least eight times the inside diameter of the duct the exhaust flow is likely to be uniformly mixed. If the measuring system is positioned at a distance of less than eight diameters, equivalent results and good mixing shall be demonstrated before use.

7.3.1.1 The following experiment helps to determine how well the exhaust gases are being mixed. Position a gas burner, such as the burners described in 11.2.3 or 11.2.4, at the location of the test specimen in the test room (or under the exhaust hood if using an open calorimeter). Burn propane gas at a constant gas flow, for example 54 L/min, which produces an 80 kW fire. Allow the gas to burn for 2–3 minutes to reach a steady state. Use a plain L-shaped 6 mm (0.25 in.) stainless steel tube facing downstream of the exhaust duct at the sampling location of the actual gas sampling probe. Traverse the tube from top to bottom of the duct in 25 mm (1 in.) increments. Record the combustion gas concentration at each position and inspect the recorded values. If gas concentrations are fairly constant (within 10 %) throughout the experiment, mixing has been achieved. If gas concentrations vary widely throughout the cross sectional area of the exhaust duct, mixing vanes or baffles need to be added to the exhaust system. Repeat these measurements until good mixing has been achieved.

7.3.2 Sampling probes shall collect samples across the full diameter of the exhaust duct, and thus, preferably be of the bar type and minimize disturbance of the air flow in the duct. Ring type sampling probes also are acceptable, although they do not collect gas samples across the full diameter of the duct. In either case turn the intake of the sampling probe downstream to prevent soot from clogging the probe. The sampling probe shall be manufactured from corrosion resistant materials, such as stainless steel or polytetrafluoroethylene. Collect the combustion gas samples across the entire diameter of the exhaust duct. Install the gas sampling probe at the center of the cross-sectional area of the exhaust duct with the holes facing downstream of the flow.

7.3.2.1 Inspect the sampling probe frequently and remove any particulate deposit in the holes or in the line. The frequency of required cleaning of the probe depends on the frequency and intensity of the tests conducted in any facility. When all components of the gas train, such as all filters, cold bath, valves, rotameters and pump are clean, but a sufficient flow cannot be maintained through the analyzers, this is an indication that the sampling probe holes are probably clogged. In this case, the sampling probe shall be removed and cleaned. Methanol or other solvents are often needed to remove hard soot deposits and other contaminants. Reinstall the gas sampling probe after cleaning and make sure all the openings are sealed and there is no leakage into the system. The sampling probe shall be cleaned with a frequency no less than monthly.

7.3.2.2 It is possible to install the gas sampling probe facing upstream of the flow; however, in this condition the probe holes will clog more quickly and need to be cleaned more often.

7.3.3 *Gas Sampling Line*—The gas sampling line shall be

positioned at the desired location, made from a material not influencing the concentration of the combustion gas species to be analyzed. Transport combustion gases through a heated (preferably electrically) line to prevent condensation of moisture or other combustion products in the line. Maintain the heated line at a temperature of at least 110°C (230°F). Remove particulates contained in combustion gases with inert filters. Use oil-free pumps, such as diaphragm pumps, to transport sample gases from the test room to the gas analyzers. All tube fittings and pipe connections throughout the length of the gas train shall be gas tight so as to ensure that no gas leakages occur in the system. This is particularly crucial on the suction side of the gas sampling pump where outside air might be drawn into the system and dilute the stream of sample gas. Leakage of air into the sample gas will cause serious errors in the gas concentration measurements.

NOTE 6—All tube fittings and pipe connections in the gas analysis system shall be made of stainless steel or other corrosion resistant materials to avoid corrosion. Corrosion of gas handling tubes and fittings potentially affects the chemical composition of the sample gas and causes serious errors in the test measurements.

NOTE 7—Heated lines are not necessary for the measurement of carbon monoxide, carbon dioxide, or oxygen; however, utilization of heated lines is necessary for the following gases: water, hydrogen chloride, and condensable hydrocarbons. Moreover, even if these gases are not being measured, the use of heated lines prevents their deposition inside the sampling tube, which potentially will reduce or obstruct the free flow of gases inside the line.

#### 7.3.4 *Particulate Filter and Removal System for Condensables:*

7.3.4.1 The gas sample entering the gas analyzers shall be free of moisture, soot, condensable hydrocarbons, and any other particulates. Use in-line filters to remove soot and other particulates before the gas sample enters the gas analysis system. These filters shall be replaced daily; however, in some cases line filters need to be replaced after each fire test, especially if the burn has been particularly intense or especially sooty. Soot filters shall be replaced when needed, to ensure a free and sufficient flow of sample gas through the gas analyzers during the test.

7.3.4.2 Use a removal system to remove the water content of the gas sample, and condensables, continuously, as discussed in 7.3.4.3-7.3.4.5.

7.3.4.3 One option for water removal system is a cold trap. A cold trap (refrigeration system) consists of condensing unit, compressor and evaporator unit, and often also contains a temperature control unit.

7.3.4.4 The concept of the cold trap is to continuously cool the sample gas in order to condense the water content in the mixture of gases and provide a moisture-free stream of sample gases to the gas analyzers. An ice bath often is used as a valid alternative.

7.3.4.5 A different valid alternative to a chiller of any kind is the use of a selective permeability membrane drier, which has been shown to be very effective (7).

7.3.4.6 Neither the soot filters nor the condensable removal system shall introduce a large “dead” volume into the gas train. A large “dead” volume is a potential contributor to the loss of



peak gas concentration values, especially in the case of sharp peaks.

NOTE 8—Time constants of gas analyzers affect “dead” volumes. Even though various digital techniques have been proposed to correct system response errors due to “dead” volume, avoidance is recommended.

#### 7.4 Gas Analyzers:

7.4.1 The measurement of oxygen concentration is at the heart of the determination of rate of heat release by the principle of oxygen consumption. For improved accuracy in rate of heat release measurements, particularly for large fires, measurements of carbon monoxide and carbon dioxide concentrations are helpful.

7.4.2 *Specifications for Oxygen Measurement*—Measure the oxygen concentration with an accuracy of at least  $\pm 0.04\%$  of full scale in the output range of 0 to 21 volume % oxygen, or  $\pm 0.01$  volume % oxygen, in order to have adequate measurements of rate of heat release. Take the combustion gas sample from the end of the sampling line. Calculate the time delay, including the time constant of the instrument, from the test room; it is a function of the exhaust duct flow rate. The time delay is the time to transport sample gases from the source to the inlet port of the gas analyzer, and it shall be as short as possible, up to a maximum of 30 s. The response time of the gas analyzer shall not be greater than 5 s and preferably be in the order of 1 s or less. The lag time is simply subtracted from the recorded time to obtain the actual time of the event at the inlet of the gas analyzer.

NOTE 9—The most satisfactory oxygen analyzers are those of the paramagnetic type (see Appendix X1).

7.4.3 *Specifications for Carbon Dioxide and Carbon Monoxide Measurement*—Measure the combustion gas species with an instrument having an accuracy of at least  $\pm 0.1$  volume % for carbon dioxide and  $\pm 0.02$  volume % for carbon monoxide. A suitable output range is 0 to 1 volume % for carbon monoxide and 0 to 6 volume % for carbon dioxide. Take the combustion gas sample from the end of the sampling line. Calculate the time delay, including the time constant of the instrument, from the test room; it is a function of the exhaust duct flow rate. It shall be a maximum of 30 s. The response of the gas analyzers shall not be greater than 5 s and preferably be in the order of 1 s or less.

NOTE 10—Carbon monoxide and carbon dioxide non dispersive infrared analyzers have been shown to be satisfactory. Instruments exist, which assess both carbon monoxide and carbon dioxide.

NOTE 11—The upper limit of the analyzers is exceeded occasionally in flashover situations. This error, however, often is of relatively low consequence, because, frequently, it is measured in tests after flashover.

7.4.4 *Considerations for Response Times in Calculation of Rate of Heat Release*—The calculated rate of heat release depends on measured values of several time dependent parameters: temperature, differential pressure, and concentrations of oxygen, carbon monoxide, and carbon dioxide (if the latter two are measured). It is of utmost importance that all values of these parameters used in the heat release equations correspond to the same event and time. If the values of these parameters do not correspond to the same instant in real time, the rate of heat

release calculations will be inaccurate. The response of thermocouples and pressure transducers to variations in temperature or pressure in the exhaust duct is usually rapid and normally corresponds to a negligible time delay; however, the time response of gas analyzers is not rapid, and time delays shall be measured. There are two principal types of delay involved in gas measurements: the time for gas to be transported from the source to the inlet port of the gas analyzer (the lag time), and the time it takes the gas analyzer to respond to the incoming sample and actually measure gas concentration (the “response time,” or “time constant,” of the gas analyzer). The response time of any instrument is a characteristic of its system and depends on the type of the instrument and its principle of operation. The “delay time” is the sum of lag time and instrument response time.

7.4.5 *Determination of the Lag Time*—The lag time is the time period between the moment when the gas is introduced at the source and the moment when the gas analyzer begins to respond to the gas concentration. The lag time is measured by introducing a volume of a known gas, such as carbon dioxide, at the source, at time zero, and plotting the gas analyzer output against time.

7.4.5.1 For any flow rate in the exhaust duct, one method of assessing lag time is by bursting a large balloon filled with a known gas, such as carbon monoxide, carbon dioxide or methane (if total hydrocarbons are being measured), and recording the gas analyzer’s response. The lag time then is simply subtracted from the recorded time to get a corrected time.

7.4.6 *Response Time*—Correction for response time is mathematically more complicated and usually requires computer programming; however, for most practical purposes in full-scale fire testing, response times simply are considered as additional delay time and added to the lag time. If the instrument response time is small, less than 1 s, the error due to its effect will not be significant.

7.4.6.1 If the response times of each gas analyzer differ, it is crucial to make response time corrections for each unit individually; therefore, a single constant delay time correction cannot be used for all gas analyzers, unless actual response times are similar.

7.5 *Flow Rate*—In order to measure the volumetric flow in the exhaust duct, install a bidirectional probe at the centerline of the duct parallel to the flow direction. Measure the volume flow rate in the exhaust duct with an accuracy of at least  $\pm 6\%$ . The response time to a stepwise change of the duct flow rate shall be a maximum of 5 s to reach 90 % of the final value.

7.5.1 Install the bidirectional probe at a position where the flow is fully developed and combustion products gases are well mixed. This will be at least eight duct diameters downstream of the last turn. Install the bidirectional probe at least 0.30 m (1 ft) upstream of the gas sampling probe. The bidirectional probe detects any pressure differential, the difference between the total pressure and the static pressure, in the exhaust duct. The probe consists of a stainless steel cylinder, with a solid diaphragm in its center, dividing it into two chambers. The



pressure taps on either side of the diaphragm support the probe. Position the axis of the probe along the centerline of the duct.<sup>11</sup> Alternative probes are acceptable, if equivalency of results has been demonstrated.

7.5.2 An electronic pressure transducer with an analog output is required to be used in conjunction with the bidirectional probe. From this and the temperature measurement in the duct, calculate the volume flow rate of the smoke in the exhaust duct using Eq 1 (see also Annex A2 for further details). Connect the two pressure taps of the bi-directional probe to the differential pressure sensor by means of flexible tubing.<sup>12</sup> Ensure that there are no leakages from or to the system. The connecting tubes shall be well insulated and protected from temperature changes or physical damage. The length of the tube between the bidirectional probe and pressure sensor shall be kept at a minimum, typically not much more than the actual distance between the two instruments (leave as little slack as possible). Connecting tubes shall not be folded, bent or broken.

$$\dot{V}_s = \frac{C * \sqrt{[\Delta p * T_e]}}{\rho_0 * 273.15} \quad (1)$$

where:

$\dot{V}_s$  = the volumetric flow rate, under standard conditions (25°C and 1 atm pressure), in m<sup>3</sup>/s;

$T_e$  = the gas temperature in the exhaust duct near the bidirectional probe, in K;

$p$  = the pressure differential across the bidirectional probe, in Pa;

$\rho_0$  = the density of air at 273.15 K temperature; and,

$C$  = a practical calibration factor.

7.5.3 The bidirectional probe in the exhaust duct shall be inspected and cleaned frequently to ensure that all holes and tubings are open fully and the probe is positioned correctly. The frequency of cleaning of the probe depends on the frequency and intensity of tests conducted in any facility. Remove connecting tubes from pressure tabs and blow air through both tabs to remove the soot. For less frequent cleaning, such as monthly clean-up, the bidirectional probe shall be removed and cleaned. Methanol or other solvents often are needed to remove hard deposits of soot and other contaminants. Reinstall the probe carefully at the center of the exhaust duct parallel to the direction of air flow, and make sure all the openings are sealed, and there are no leakages into the system.

7.5.4 *Measurement of Flow Rate Profile in the Exhaust Duct*—In order to determine whether the flow in the exhaust duct is developed fully, the flow rate profile in the duct shall be measured. The velocity profile also is needed to determine  $C$  in Eq 1, the ratio of average to maximum flow rates in the exhaust duct. Figs. 4 and 5 show ways of measuring the flow rate profile. Fig. 5 shows one type of flow rate profile obtainable. In order to obtain the velocity profile, turn on the exhaust fan and run air through the exhaust duct at the desired flow rate, such as 0.47 m<sup>3</sup>/s (1000 ft<sup>3</sup>/minute). Position the bidirectional probe at 25 mm (1 in.) intervals from one side of the duct to the other.

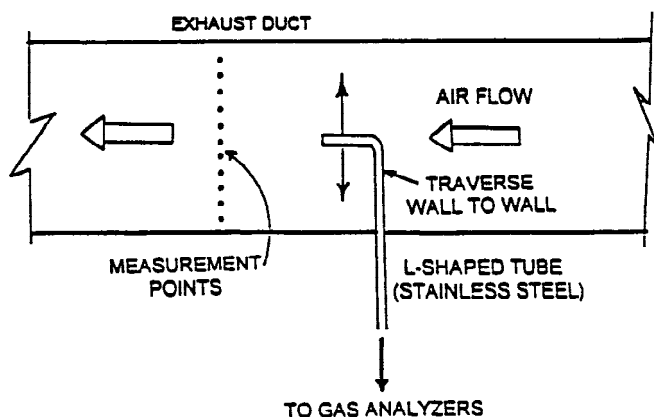

FIG. 4 Testing the Mixing of Gases in the Exhaust Duct

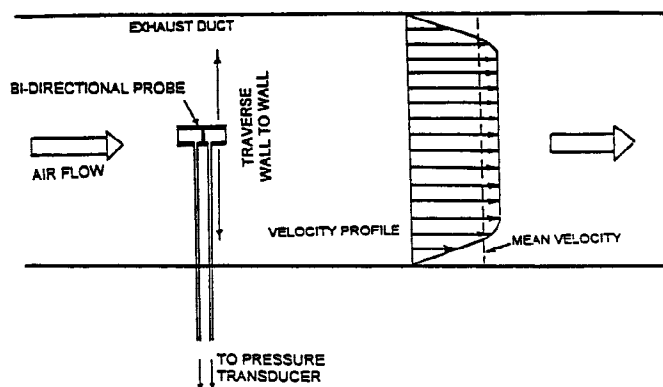

FIG. 5 Bidirectional Probe and Velocity Profile in the Exhaust Duct

Measure the flow rate at each position and obtain an overall profile. Then, determine the flow rate in the duct, and divide the average flow rate by the centerline flow rate to obtain  $k$ . Repeat this procedure at different exhaust flow rates.

7.6 *Temperature Measurement*—Use Chromel-Alumel type K thermocouples, shielded against high heat with insulation capable of resisting temperatures at least to 1200°C (2200°F). The thermocouple wire gage shall be 0.51-mm diameter (24 AWG). The total length of thermocouples from the point of measurement to the data acquisition system shall be kept at a minimum. Ensure that the entire length of thermocouple wires is protected against heat and physical damage. To prevent the possibility of breakage thermocouple wires shall not be bent at sharp angles. Make sure thermocouple leads have no contacts or connections other than the junction point. Install connectors in such a way that the bare wires do not contact each other. Thermocouple circuits shall involve at least two junctions: one junction is the measurement point (hot junction), where the two leads are welded together to make a small bead, and the other junction shall be at a known temperature, commonly called reference temperature (cold junction). A common reference temperature is an ice bath kept at 0°C (32°F). The cold junction is required to make temperature measurements using thermocouples. The common arrangements are described in many thermocouple manufacturer’s manuals and text books. Many data acquisition systems include software or hardware thermocouple compensation circuits, which eliminate the need for

<sup>11</sup> A pressure differential sensor in the range of 0.0–1.0 torr (0.000–0.5353 in. water), with an electronic signal conditioning display unit providing 0–10 VDC output has been found satisfactory.

<sup>12</sup> Suitable types of tubing include “tygon” and polytetrafluoroethylene tubing.

using a cold reference junction, such as ice bath. Depending on the type of data acquisition system, the temperature is either calculated automatically by the software and stored by the system, or programming is required to calculate the temperature from the measured voltage. Laboratories shall refer to their data acquisition operating manuals for proper application.

NOTE 12—Although higher gage (thinner) thermocouple wire results in slightly more accurate temperature measurements and increased sensitivity, full-scale fire testing typically involves rugged conditions, which makes the use of very fine thermocouples difficult and impractical in such environments. Consequently, it is important to use the specified type and gage of thermocouples to ensure consistency of test results.

7.6.1 A thermocouple, used to measure the temperature of the incoming gases, shall not be installed downstream in the wake of the bidirectional probe. It shall be installed upstream of the probe, where the exhaust flow is well mixed, such that the fully developed flow of air reaching the probe will not be disturbed. The thermocouple shall be installed at a distance of at least one duct diameter from the bidirectional probe. Alternative thermocouple placements are acceptable provided equivalency of test results has been demonstrated.

7.6.2 For a more representative measurement of exhaust flow temperature a thermopile is installed across the cross-sectional area of the exhaust duct, and the average temperature used in Eq 1. Several thermocouples are connected in series or parallel to make a thermopile. This arrangement increases the sensitivity of temperature measurements. If the hot junctions are at different temperatures and thermocouples all have the same resistance, the temperature measured is the average temperature if the thermocouples are linear over the temperature range being measured. Since the thermopile shall be positioned at a location where duct flow is well mixed, this condition will be satisfied. Fig. 6 shows multiple-*junction thermocouples in series and in parallel. If  $n$  thermocouples are connected in series, the output will be  $n$  times as great as a*

single couple. The parallel combination generates the same voltage as a single couple if all measuring and reference junctions are at the same temperature. If the measuring junctions are at different temperatures and the thermocouples are all the same resistance, the voltage measured is the average of the individual voltages.

7.7 *Smoke Measurement*—Install an optical system for measurement of light obscuration across the centerline of the exhaust duct. Determine the optical density of the smoke by measuring the light transmitted with a photometer system consisting of a lamp, plano convex lenses, an aperture, a photocell, and an appropriate power supply (Fig. 7). Construct the system so that soot deposits on the optics during a test do not reduce the light transmission by more than 5%. Alternatively, instrumentation using a laser beam system, with an 0.5 to 2.0 mW helium-neon laser, instead of white light system also is acceptable (see Figs. 8 and 9). It has been shown that white light and laser systems will give similar results (9-11).

NOTE 13—One way of preventing soot buildup on lenses is to use a gas purge with air or nitrogen.

7.7.1 Install the light source and detector units across the centerline of the exhaust duct preceded by at least eight diameters of duct. The light source and detector units shall be aligned perfectly in order to correctly measure the smoke obscuration. Smoke obscuration shall be zero when there is no smoke in the exhaust flow. Install the light source and detector units such that the units do not protrude into the exhaust duct and disturb the flow. Make holes in the duct just large enough for mounting the units. Seal any openings, other than those needed for purging of laser optical systems, with high temperature sealant to prevent leakages of air into the duct. Construct the system so that deposits on the lenses during a test do not reduce the light transmission by more than 5%. For this purpose, supply a flow of purge air to continuously blow over the lenses of both units during the test. The purge air shall be clean and shall not interfere with the flow of smoke in the duct.

## 8. Instrumentation in the Test Room

8.1 Test room instrumentation is associated with mass loss measurements, and optional additional measurements, such as temperature, smoke obscuration, and toxic gas concentrations, but is independent of any heat release measurements.

8.1.1 *Weighing Platform*—Use a weighing platform to continuously measure the mass loss of the burning specimen.

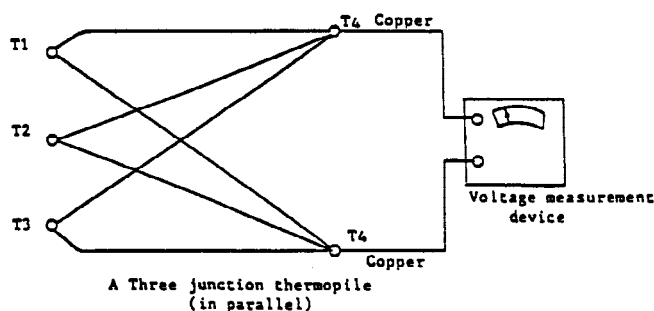
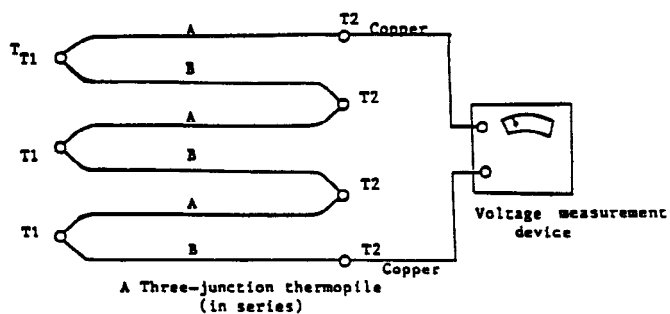

FIG. 6 Multiple-Junction Thermopiles

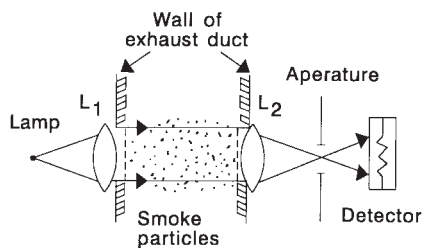
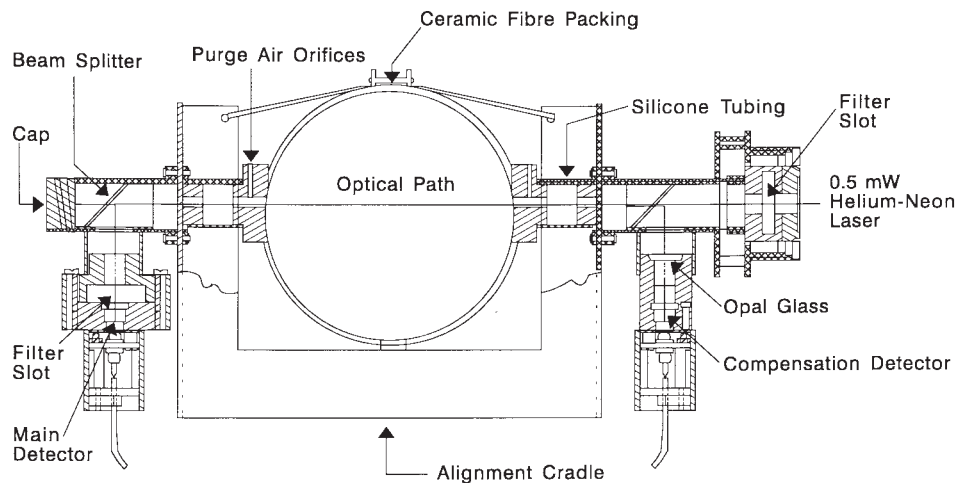
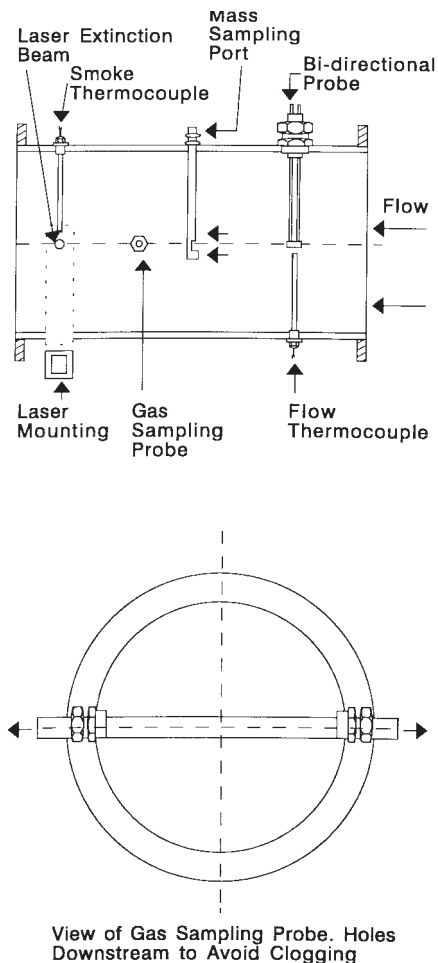

FIG. 7 Optical System Using a White Light



**FIG. 8 Laser Smoke Measurement System**



**FIG. 9 Recommendations for Mounting the Laser Beam and Other Instrumentation in Exhaust Duct**

These mass measuring devices (load cells) usually are sensitive to severe changes in temperature. Most load cells are not designed to withstand high temperature and large temperature variations; thus, load cell elements shall be well insulated, and weighing platforms shall be protected carefully against direct flames and high temperature. The weighing platform shall

consist of a horizontal thermal barrier, capable of protecting the sensitive element from the high temperatures, placed above the mass measuring device. Another effective way of protecting the weighing platform is to surround the base of the device with cooling water tubes, provided it does not cause interference with the mass measurement. Also, carefully protect and insulate any wires or cables connected to the weighing platform.

8.1.1.1 The thermal barrier shall consist of a galvanized steel pan, placed under the test specimen. The pan shall be constructed of nominally 1.6-mm ( $\frac{1}{16}$ -in.) thick steel, and have dimensions of no less than 1.0 m  $\times$  1.0 m (approximately 39 in.  $\times$  39 in.), with a uniform raised lip of the same material, 100  $\pm$  10 mm (approximately 4 in.) high, on each side, to catch falling material. The bottom of the pan shall be covered by a tight fitting sheet of standard gypsum board (finish side up), of nominally 13 mm (0.5 in.) thickness. The barrier shall be used to protect the load cell. The gypsum board shall be clean before the start of a test. The sheet shall be replaced for each test. In some cases, it is suitable to have thermocouples near the body of the load cell to monitor the temperature variations during burning.

8.1.1.2 The weighing platform shall be able to measure at least 90 kg (200 lb), with an accuracy of  $\pm 150$  g ( $\pm 0.3$  lb). Install it in such a way that neither the heat from the burning specimen nor any eccentricity of the load affect the accuracy. Do not make any range shifts during measurements. Install all parts of the mass measuring device below the top level of the thermal barrier. The body of the weighing platform shall be made of stainless steel or other material capable of resisting water and other corrosive products of combustion in the high temperature environment.

8.1.1.3 Continuous mass loss measurements are not required for measurements of fire-test-response characteristics of wall linings, such as those in NFPA 265, NFPA 286, or ISO 9705.

8.1.2 *Temperature Measurement*—Such measurements are much less accurate than measurements in the exhaust duct. See 7.6 for details.



8.1.3 *Combustion Gas Analysis*—If test room concentrations of combustion gases, for example, carbon monoxide, are required, a gas analysis system will be required; however, such measurements are less accurate than exhaust duct measurements. The sequence of the gas train is the same as the one for gas analysis in the exhaust duct: sampling probe, heated line, soot filter, cold trap, plastic drying column and carbon dioxide removal column (if used), gas path pump, vent valve, flow controller and gas analyzer. The gas train also shall include appropriate spanning and zeroing facilities, as well as, calibration gases. It is recommended that all parts of gas analysis system be housed in an instrument rack. See 7.4 for details.

8.1.3.1 If required, measure the concentration of carbon monoxide in the room with an instrument having an accuracy of  $\pm 0.005$  volume % ( $\pm 50$  ppm). A suitable output range of the carbon monoxide analyzer for the room measurement is 0–10 000 ppm, or 0–1 %. The recommended upper limit is exceeded in some flashover situations. This will not be of major consequence since detailed measurements are often unnecessary at flashover.

8.1.4 *Smoke Obscuration*—Often, it is desirable to measure the smoke obscuration in the test room at a height of 1.2–1.5 m (4–5 ft) above the floor. Install the light source and the detector units at the mid length on opposite walls (see Fig. 1 or Fig. 2). The light source and the detector units shall be aligned perfectly in order to correctly measure smoke obscuration. Mount the light source and the detector units on the walls outside the room such that the units do not protrude into the room through walls. Make the holes in the walls only large enough for mounting the units. Such measurements are less accurate than exhaust duct measurements. See 7.7 for further details.

8.1.5 Flashover indicators placed on the floor of the test room have been found useful. The options are paper targets (a single piece of newsprint crumpled into an approximately 150-mm (approximately 6-in.) diameter ball) or total heat fluxmeters. Further details are found in the specific test method.

## 9. Data Acquisition

9.1 A data acquisition system, associated with a computer, is required to continuously collect, record, and store test data in real time throughout a burn test. During a test, data shall be collected at least every 6 s, particularly when any noticeable combustion is occurring. In cases where the test specimen continues slow smoldering for a long period of time, it is acceptable to decrease the frequency of data collection, to save computer storage space. In this situation, the data collection period shall be returned to the original, lower, value if any noticeable flaming activity reoccurs. The control room operator shall ensure that all necessary test data are collected throughout the entire test.

9.2 Many types of suitable data acquisition systems are available. The selected data acquisition system shall provide sufficient versatility to satisfy all requirements of a full-scale burn test, such as continuous data collection, data reduction and calculations, printing or plotting of test data, or both, and storage of test data, and shall provide room for possible future expansion and addition. A data acquisition system typically

consists of a data acquisition/control unit with built-in or added analog to digital (A/D) converters, a computer, a printer, and a plotter. The analog output signals generated by all test instruments (thermocouples, smoke monitors, gas analyzers, load cells, and pressure transducers) are connected to the data acquisition unit, which shall be programmed to collect data from each instrument at designated time intervals. The digitized test data are transferred to a computer for storage and processing. All test data shall be stored on floppy diskettes or on a hard disk and saved. Commercial software packages exist for this purpose, and some analog/digital converters include their own software.

9.3 The minimum number of required data channels depends on the type of facility being used. For exhaust duct measurements, at least three channels are required to calculate heat release rate, by measuring oxygen concentration, temperature and differential pressure. It is strongly recommended that smoke obscuration and carbon oxide concentrations also are determined in the exhaust duct, which would require at least two additional channels. Typically, for test room measurements, at least 5 data acquisition channels are required, to measure smoke obscuration, carbon monoxide, mass loss, and two temperatures. It is further recommended that spare data acquisition channels be available for collecting additional data, if needed for special purposes.

## 10. Images

10.1 Video taping of burn tests usually is not a requirement, but it is highly recommended that each large-scale test be video taped, since useful information is derived from viewing the burning process of a product, which occasionally is not apparent from the test data. Still photographs also are useful. In both cases, grid markings on the walls are helpful additions. Video tapes of the tests also are useful for research purposes or future reference. Video cameras shall be positioned at convenient locations that provide suitable observation angles. A common practice is to record all noticeable burning activities and stop recording when slow smoldering is occurring unless continuous recording of entire test is required for special purposes.

## 11. Calibration

11.1 The two kinds of calibrations required are calibration of the measurement instruments, and calibration of the facility (or the calorimeter) itself.

11.1.1 *Calibration of Instruments*—All measurement devices including gas analyzers, smoke monitors, and load cells shall be calibrated with standard sources at the beginning of each test day. Recalibration of some instruments between tests often is required. Thermocouples shall be cleaned and tested prior to testing. For each measuring device the start-up and calibration procedures specified by the instrument manufacturer shall be followed. Allow sufficient warm-up time for all instruments. The following, describes methods of calibration that typically are applicable to this practice.

11.1.2 Every testing laboratory shall maintain a complete record of all calibrations, including daily instrument calibrations and monthly (or other) heat release rate calibrations. The record will assist in identifying changes in the calibrations of

the instruments or in the system, over time. The record keeping will assist in detecting any gradual deterioration within the system.

### 11.2 Heat Release:

11.2.1 The full-scale fire testing facility, burn room or furniture calorimeter, shall be calibrated for measurement of rate of heat release. Calibration is achieved by burning known amounts of a gaseous fuel for which the heat of combustion, and therefore, the heat release rate, are known. The measured rate of heat release then is calculated from measurements taken in the exhaust duct based on the principle of oxygen consumption. For a satisfactorily operating system the theoretical and measured rate of heat release values shall be in reasonable agreement, within 6%. Agreement shall exist regardless of the exhaust duct volume flow rate or the fuel load.

11.2.1.1 Frequency of heat release calibration depends on the frequency of using the system and conducting tests. The more tests conducted in a facility, the more frequently it shall be calibrated. In addition, any changes in the system, such as replacement of a gas analyzer, and especially any modifications in the exhaust system will require calibration of rate of heat release. In normal conditions, when the facility is operating on daily basis, the system shall be calibrated at least every month.

11.2.2 Perform the calibration of the heat release instrumentation in the exhaust duct by burning propane or methane gas and comparing the heat release rates calculated from the metered gas input and those calculated from the measured oxygen consumption. The value of net heat of combustion for methane is 50.0 MJ/kg and that for propane is 46.5 MJ/kg. Position the burner in the same location where the upholstered furniture specimen is to be placed during the test. Measure the gas flow rate at a pressure of  $10 \pm 5$  kPa (standard atmospheric pressure, measured at the flow gage) and a temperature of  $20 \pm 5^\circ\text{C}$ . The calibration is potentially affected by the burner configuration.

11.2.3 A calibration burner used is a sand diffusion burner with a  $0.3 \text{ m} \times 0.3 \text{ m}$  (12 in.  $\times$  12 in.) top surface and a 0.15-m (6-in.) depth. Construct such a gas burner with a 25-mm (1-in.) thick plenum. Alternatively, use a minimum 100-mm (4-in.) layer of Ottawa sand to provide the horizontal surface through which the gas is supplied. This type of burner is shown in Fig. 10. The gas supply to the burner shall be propane, of the same quality as that used for the ignition burner, or methane. The gas for the burner flame shall not be premixed with air. Meter the flow rate of gas and keep it constant throughout the calibration test.

11.2.3.1 The sand in the burner can be replaced by a loose-fitting refractory fiber blanket of nominal density close to  $65 \text{ kg/m}^3$  (4 lb/ft<sup>3</sup>). Equivalency to the performance of a burner shall be confirmed.

11.2.4 Another calibration burner used is a pipe, with an inner diameter of  $100 \pm 1.5$  mm (4 in.), supplied with gas from beneath (see ISO 9705). The gas for the burner flame shall not be premixed with air.

11.2.5 The flowmeters used to measure the flow rate of propane for the gas burner shall be checked before every test for the correct flow rate. If the burn facility is operating daily, the flow meter shall be calibrated weekly. For this small flow

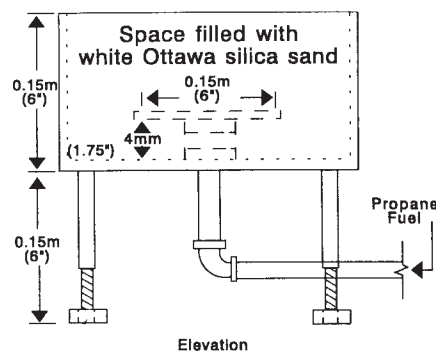
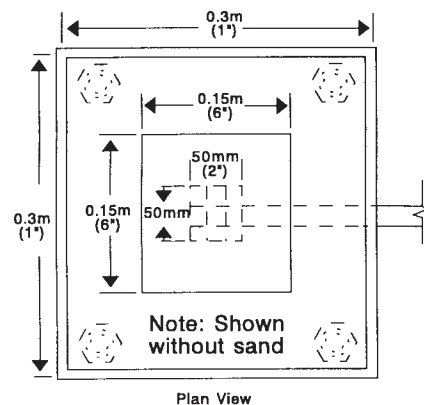

NOTE 1—See text for tolerances.

FIG. 10 Calibration Sand Gas Burner

rate, use either a dry or a wet test meter.

11.2.6 Obtain a minimum of two calibration points. Obtain a lower heat release rate value of 40 kW, and then, a higher heat release rate value of 160 kW. Approximate propane flow rates for any required heat release rate value are estimated using the following constant: 1.485 kW min/L, determined at a pressure of  $101 \pm 5$  kPa (standard atmospheric pressure, measured at the flow gage) and a temperature of  $20 \pm 5^\circ\text{C}$ . Accurate flow rates of propane gas are calculated by using an orifice plate. Alternatively, a mass flow meter or a dry test meter shall be used to measure the flow rate of the fuel gas.

11.2.7 Take measurements at least once every 6 s and start one minute prior to ignition of the burner. Determine the average rate of heat release over a period of at least one minute by the oxygen consumption method and calculating the heat release rate from the gas mass flow rate and the net heat of combustion. The difference between the two values shall not exceed 5%. Make this comparison only after steady state conditions have been reached.

11.2.8 Perform a calibration test according to 11.2.7 prior to each continuous test series. Perform a full basic calibration on a new system or when modifications are introduced.

11.2.9 When calibrating a new system, or when modifications are introduced, the response time of the measuring system shall be checked by the test sequence in Table 1. Take measurements at least once every 6 s. The response of the system to a stepwise change of the heat output from the burner

**TABLE 1 Test Sequence**

Time	Burner Output, kW
0 to 5 min	0
5 to 10 min	40
10 to 15 min	160
15 to 20 min	0

shall be a maximum of 12 s to 90 % of final value.

NOTE 14—Accurate measurement of the flow rate of propane (or other calibration fuel gases) is of utmost importance in calibrating the heat release calorimeter. Efficiency of heat release calibration largely relies on this gas flow measurement, and extreme care shall be taken in this procedure. Flow measurement devices, such as mass or volume flowmeters flow meters shall be calibrated or checked against a more precise instrument. If an electronic mass flow meter or an orifice plate is used to measure the gas flow rate, a dry test meter shall be used periodically to examine the accuracy of the flow measurements and to calibrate the flowmeters flow meters.

NOTE 15—Liquid propane tanks freeze if high flow rates are used for an extended period of time, due to the endothermic evaporation of the liquid propane which volatilizes. This decreases the temperature of the remaining fluid inside the tank, and causes problems when a portable size liquid propane tank, such as a standard 25-gal tank, is used. Freezing most likely is to occur when the liquid content of the tank is low. During heat release calibrations the flow of propane shall be monitored closely for any possible freezing. Touch the body of the tank to feel the temperature and visually inspect for frost on the outer surface. If the flow rate of the propane changes during a calibration test, stop the test, allow the tank to warm up and repeat the test or use a back up tank. To avoid the possibility of freezing, use either a larger tank or connect two or more portable tanks in series via a manifold with on/off valves. Commercial gas delivery systems set-up, which are especially designed to prevent freezing, such as heat fins or electrical heaters also are suitable. Alternative methods are the use of heated blankets or electrical heating devices surrounding the propane tanks. When using any heating devices on or near propane tanks, the devices shall be examined carefully for any malfunction causing sparks or creating open flames.

11.2.10 Check the precision of the system at various flow rates by increasing the flow in the exhaust duct in four steps, starting from  $0.25 \text{ m}^3 \text{ s}^{-1}$  (at 0.1 mPa and 25°C) up to maximum. The recommended heat output from the burner is 160 kW. The change in measured rate of heat release, comparing time average values over one minute shall not be more than 10 % of the actual heat output from the burner.

11.2.10.1 If the test to be conducted follows ISO 9705 at heat inputs of 100 kW and 300 kW, follow the calibration instructions given in the standard.

11.2.11 The use of a higher rate of heat release for calibration, for example 500 kW, generally will lead to higher accuracy in test results.

11.2.12 Dry or wet test meters shall not be left in the line continuously to minimize the possibility of damage due to inadvertent overpressurization. Consult the operation manuals of the meters for proper application. Use of rotameters for accurate flow measurements, especially high flow rates, such as those used for sand burner, generally is undesirable and is not recommended. If rotameters are used, they shall be calibrated very carefully under standard conditions and be operated under same conditions (gas temperature and especially pressure) in the test.

11.2.13 If the system operates at variable exhaust flow rates, conduct heat release calibration tests at several exhaust duct

flow rates, ranging from the minimum to the maximum volume flow rates that would typically be used in tests. At each exhaust flow, all combustion products shall be collected by the exhaust duct. The amount of gases that spill over or escape the collection hood shall be negligible.

11.2.14 As already stated in 5.4, it is important that during each test a free and sufficient flow of make-up air be available to facilitate the combustion process, without creating any forced flow of air into or out of the test room. The exhaust hood shall be large enough to achieve this objective. Adequate ventilation or air supply usually is achieved when the test room is housed in a larger enclosure. If the enclosure is such that the walls of the burn room are closer to the enclosure walls than the guidelines in 5.4, additional openings in the enclosure potentially are required to ensure sufficient supply of air into the test facility. In such a case, the optimum opening size shall be determined, as in 11.2.14.1, and then, maintained in the actual tests.

11.2.14.1 If the enclosure facility is small conduct a calibration test (see 11.2.7) with an 80-kW propane gas source, while successively adjusting the size of the opening. Plot the rate of heat release, production of carbon monoxide and carbon dioxide and depletion of oxygen versus time, and find the size of the opening that provides the optimum burning pattern. An optimum pattern will lead to constant concentration levels during the burning of a fixed amount of propane. Conduct the actual specimen tests under the optimum conditions obtained by this procedure. If the ignition source to be used in the test is larger than 80 kW, use larger calibration sources to determine optimal conditions.

11.3 *Smoke Obscuration Monitors*—Allow for the required warm up time recommended in the manufacturer's user manual. Calibrate the smoke obscuration monitors to read correctly at zero, and 100 % transmission, and at two or more other values, for example 50 % and 75 %, by using neutral density filters, daily. Prior to the start of each day's testing check the 100 % transmission (0 % obscuration) reading and perform the calibration with the two neutral density filters. If 100 % transmission is not obtained, clean the lenses of any soot deposits and recalibrate until the correct transmission is obtained.

11.4 *Load Cell (Weighing Platform)*—Calibrate the mass measuring device by loading the weighing platform with known masses corresponding to the measuring range of interest. Calibration weights shall be within the range of masses of test specimens. Typically masses of 10 kg (22 lb) and 20 kg (44 lb) are appropriate for Test Method E 1537 or Test Method E 1590, while masses of 25 kg (55 lb) and 50 kg (110 lb) are more appropriate for Test Method D 5424 or Test Method D 5537. The appropriate masses for the expected mass loss shall be used. If heavy test specimens are to be tested the weighing platform shall be calibrated with at least one mass higher than half the expected mass loss. The weighing platform shall also be checked against smaller weights, in the order of 500 g (1.1 lb) to 150 g (0.3 lb), to test the accuracy of mass measurements at low ranges.

11.4.1 Carry out the load cell calibration daily, prior to testing. Make sure the load cell indicates zero mass before



placing the test specimen on the platform. Ensure that a zero reading is obtained by taring the mass indicator (electronic unit of the mass measuring device).

11.4.2 The linearity of load cell platforms occasionally changes under burn room conditions. Use, at regular intervals, a graded series of weights, ranging from 500 g to 20 kg (1.1 to 44 lb), and record the output. Plot the recorded masses against actual mass and examine the linearity. Do proper adjustment or apply an appropriate correction factor if necessary.

11.4.3 The weighing platform and thermal barrier shall be cleaned after each test. Often, molten residue falls on the platform surface and contribute to the heat release of the next test specimen if not cleaned. The gypsum board fraction of the thermal barrier shall be replaced after each test.

11.5 *Gas Analyzers*—Calibrate gas analyzers daily prior to testing. Turn on the analyzers and allow warm-up time as prescribed by the manufacturer, in the corresponding instruction manual.

11.5.1 Find out if any of the analyzers require a steady flow of a gas, such as air or other gas, during the warm-up time. If so, turn on the pump, or an air or gas supply, and allow required flow of clean air (or gas, as appropriate) into the gas analyzer during warm-up time.

11.5.2 Use a zero gas and a span (calibration) gas to calibrate each gas analyzer. Maintain the designated flow of the calibration gases through the gas analyzers. Maintain the same flow rate of the combustion gases during the test. During the test frequently monitor the flow rate of the sample gas and readjust the flow, if necessary. At the end of each test check the analyzer's readout for possible changes or drifts. If the correct readout is not achieved by minor adjustment of the zero knob, recalibrate the analyzer prior to performing the next test.

NOTE 16—Accurate measurement of gas concentrations often is a difficult task and requires extreme care and attention. Gas analyzers are sensitive to changes in temperature, pressure, and flow rate of the gas sample and the presence of any contaminants (moisture, particles, etc.) in the gas flow. Follow the manufacturer's instructions carefully and maintain the required conditions throughout the test.

11.6 *Thermocouples*—Visually inspect thermocouples for any possible damage or breaks. Ensure the heat shield (insulation) is in good condition and all parts of the thermocouple leads are covered. Test thermocouples by holding a heat source, such as a small flame, to the thermocouple junction. Replace the thermocouple if erratic readings are observed. Clean soot deposits from the thermocouple junction. Conduct this procedure daily. In the case of severe fires, inspect thermocouples after each test.

11.7 *Calibration Check List*—Every testing laboratory shall maintain a calibration log check list, which consists of the schedule of calibrations, as follows:

11.7.1 Do before each test.

11.7.2 Do daily.

11.7.3 Do weekly.

11.7.4 Do monthly.

11.7.5 Do only after repairs or installation of new instruments.

## 12. Conditioning

12.1 Prior to testing, condition the specimen for at least 24

h, unless requested otherwise by the test procedure, in an atmosphere at a temperature of  $21 \pm 3^\circ\text{C}$  ( $70 \pm 5^\circ\text{F}$ ) and a relative humidity of less than  $55 \pm 5\%$ . Specimens shall be tested within 10 minutes of removal from such conditions if test room conditions differ from the above.

NOTE 17—Moisture content of some test specimens (notably cellulosic materials) is of significant importance. In such cases, consideration shall be given to stabilizing specimen moisture content and including this pretest information in the test report (see 14.1.1.9).

## 13. Running a Test

13.1 *General*—At this point, it is assumed that the operator has a fully operational facility and has followed all the steps indicated, including test specimen conditioning. Measure the mass and dimensions of the sample. Record a description of the sample and take pretest photographs if desired.

13.2 *Checking Gas Analyzers, Sampling Lines, Filters*—Do not start the test until all instruments have been properly set up. This includes calibration, checking, zeroing, and spanning of gas analyzers. Set gas analyzers in the "run" mode, drawing air from the exhaust duct or from the test room, as appropriate. Before each new test, check flows through the analyzers to ensure that flows are the same as used in the calibration. Flows also shall be checked frequently during the course of each test to ensure that they are not fluctuating due to clogged filters, icing of the cold trap, or clogging of sampling lines. If gas flows through the analyzers do change during the test, replace the filters (at the end of the test) and check for icing in the cold trap and clogging the sampling line. Always start the day's first run with clean filters and inspect them after each test, replacing, if necessary. If icing occurs in the cold trap, turn off the power to the cold trap and allow to thaw, then drain the water from the collection tube. If gas analyzers have more than one range, they shall be used in the appropriate range at the start of the test. The readout of the analyzers shall be monitored constantly and ranges changed, if necessary. Whenever a range is changed, note the scan number and the time at which this change occurred. Apply the appropriate conversion factor for that range when printing or processing the test data. Try to use the lowest possible range in every stage of burning to achieve the highest sensitivity of measurement. Check the heated sampling lines to verify that they are operating correctly. Also check that all sampling pumps are running.

13.2.1 Check the flow through the soot filter periodically during the test. If clogging appears to be occurring, switching to another filter, in parallel to the first one, is the recommended procedure.

13.3 *Checking the Cold Trap*—If a cold trap is being used, check its temperature setting to be sure it is at the desired set point before each test.

13.4 *Setting the Exhaust Duct Flow*—The exhaust system shall be operated normally at a constant volumetric flow rate, at a level based on the expected fire performance of the test specimen. Generally, there are two main factors that shall be considered in finding an optimum exhaust flow rate. On the one hand, the flow rate shall be sufficient to ensure collection of all combustion products through the exhaust system, which will tend to maximize the flow rate. On the other hand, the accuracy of gas concentration measurements is maximized by

minimizing the amount of entrained air that is pulled into the system, to avoid dilution of the combustion products. The system, therefore, shall be run at a compromise flow rate that best satisfies both objectives simultaneously.

13.4.1 If the operator has no prior knowledge of the fire behavior of a test specimen, it is recommended the test be conducted at a sufficiently high exhaust flow rate to ensure all combustion products are collected. If it is anticipated that the test specimen will generate relatively low levels of heat release, it is desirable to operate the system at lower exhaust duct flow rates. If due to unexpected growth of fire intensity it is necessary to increase the exhaust flow rate during the test, the speed of blower shall be increased very gradually, not suddenly, to avoid significant errors in the calculated values of heat release rate resulting from delay times associated with the gas analyzers. This is due to the fact that velocity and oxygen concentration readings are no longer in good synchronization because of a sudden change in velocity of gases in the exhaust duct.

13.4.2 For most facilities, especially when using test rooms, exhaust flow rates of less than 0.24 m<sup>3</sup>/s (500 ft<sup>3</sup>/min) are not recommended. For ignition sources of up to 100 kW, a flow rate of about 0.47 m<sup>3</sup>/s (1000 ft<sup>3</sup>/minute) usually is sufficient, while ignition sources of 300 kW likely are to require flow rates of at least 1 m<sup>3</sup>/s (2130 ft<sup>3</sup>/minute).

13.5 *Smoke Monitors*—Before starting each test make sure the smoke obscuration monitors indicate zero obscuration (100 % transmission) and no object is obstructing the light beam path.

13.6 *Ignition Source*—If the ignition source is a burner, prior to setting it up, and before each test, make sure that the burner is clean and all flame holes are fully open. Clean any soot or other deposits from the burner. A solvent, such as methanol, is suitable to clean deposits. Inspect all holes visually to ensure they are open. Run pressurized air through the burner to clear the holes. A pin is suitable for manually clearing badly clogged holes. When using a mechanical cleaning method for the burner take precautions to ensure that the shape and size of the small holes is not altered.

13.6.1 Prior to using the gas ignition burner, turn on the fuel gas at the main source and set the regulator valve at the desired pressure. Run fuel gas through the burner and light the gas. Set the fuel gas flow at the desired flow rate and allow the burner test conditions to stabilize. Once conditions have been optimized, stop the flow of gas through the burner, and allow the burner to cool before using it with a test specimen.

13.6.1.1 The ignition source in Test Method E 1537, a square gas burner, is a low pressure burner and requires very low gas pressure to operate. The pressure of propane gas through the square gas burner shall therefore be kept at a minimum. Fixed regulators are usually not adequate to supply propane gas through the burner. Use an adjustable pressure regulator, and set the regulator at the lowest pressure that will allow the desired propane (13 L/min) to flow through the burner. To obtain the desired propane flow rate, adjust the flow measurement device before increasing the line pressure. Consult a flammable gas handling expert for the propane tank and regulator valves set up.

13.7 *Checking the Weighing Platform*—The weighing platform shall be checked prior to each test to be sure it is indicating the correct mass. Before placing the test specimen on the platform, tare the electronic indicator to read zero. Place the test specimen on the weighing platform, and ensure that it reads the mass of the sample. If not, adjust the corresponding knob (usually labeled “gain”) to read the desired value.

13.8 After all instruments are calibrated, and the exhaust duct flow and propane flow through the ignition burner are set, bring the test specimen into the test room and position it on the weighing platform according to the instructions and position the ignition source in place as specified in the test procedure.

13.9 *Setting Up Data Acquisition System and Starting the Test*—At this point, it is assumed that all instruments are calibrated, the exhaust flow is set, the propane ignition burner and the test specimen are set up and the video recorder is ready. Log onto the data acquisition routine and obtain a readout of all instruments for initial values (pretest data). If all readings are satisfactory, log onto the data acquisition routine and prepare to collect test data. Before starting the test and data recording, make a last visual check of all systems as in 13.9.1-13.9.8 and correct as necessary.

13.9.1 *Exhaust Fan On*, check pressure transducer indicator.

13.9.2 Check cold trap temperature.

13.9.3 Check heated lines and filter (indicator lights on or touch the line quickly).

13.9.4 Check flow meters for oxygen, carbon monoxide, and carbon dioxide analyzers.

13.9.5 Check outputs from oxygen, carbon monoxide, and carbon dioxide analyzers (refer to pretest data collected).

13.9.6 Check smoke meters output (refer to pretest data collected).

13.9.7 Check the weighing platform output (refer to pretest data collected).

13.9.8 Check thermocouples readouts (refer to pretest data collected).

13.10 If all systems are satisfactory, start the test. Start all recording and measuring devices (including the computer data acquisition system and video recorder) at least two minutes before starting the ignition burner. Start the ignition source. If it is a gas burner, allow it to burn for at least 60 s, to monitor for a constant flow rate of gas, and adjust, if necessary. At the end of the prescribed burn period (which often precedes the end of the test), turn off the gas flow and gradually remove the gas burner from the test specimen. Make sure that the burner does not touch or hit any part of the specimen during removal.

13.11 *Observing the Test*—A minimum of two operators shall be present to run a test, including at least one of them in the vicinity of the test room, to observe the burning specimen, and one of them attending to the data acquisition system and all other instruments, to ensure they are functioning correctly during entire test period. Additional personnel shall be available in the vicinity in order to quickly aid in the extinguishment of the fire, if rapid fire growth, or the possibility of flashover, occurs.

13.11.1 Throughout the test closely monitor all instruments. In particular, periodically observe the rotameters on the gas analyzers to ensure that flow rates are not varying. If gas

analyzers have more than one range, make sure that they are operating at the appropriate range. This is particularly critical when the intensity of burning increases, since the concentration of gases, such as carbon monoxide and carbon dioxide often exceeds the lower ranges of the gas analyzers. In such cases, change to a higher range and record the time when the shift occurred. Consider this range shift, if any, when processing the test data.

13.11.2 Video tape the test continuously, until all evidence of combustion, including smoldering, has ceased. After all flaming ceases, and it appears that smoldering will continue for an extended period of time, periodic videotaping, rather than continuous video taping, is acceptable, at the discretion of the test facility or the requester. For example, video tape for 10–30 s, at five-minute intervals. Resume continuous video recording immediately if flaming combustion resumes.

13.11.3 Observe the burning specimen continuously. Make sure all combustion products are collected by the exhaust duct and none escapes to the surroundings. The test room operator shall look for and note major events occurring during the test. The following test events shall be recorded, if they occur:

- 13.11.3.1 Ignition of specimen.
- 13.11.3.2 General description of the burning behavior.
- 13.11.3.3 Occurrence of pool fire under the specimen.
- 13.11.3.4 Any special pattern of burning, such as lingering flames at corners or crevices of test furniture.
- 13.11.3.5 Opening of seams and penetration of flames to the filling materials.
- 13.11.3.6 Generation, accumulation and intensity of smoke (visual description).
- 13.11.3.7 Melting and dripping.
- 13.11.3.8 Pieces of furniture falling off.
- 13.11.3.9 Flame-out time.
- 13.11.3.10 Any other event of special interest.

13.11.4 *End of Test*—Tests are normally concluded when one or more of the following conditions occurs, but the test method itself or the requester will establish the end point as follows:

- 13.11.4.1 All signs of combustion have ceased and the remaining specimen is at approximately room temperature.
  - 13.11.4.2 Flashover appears to be imminent.
  - 13.11.4.3 One hour of testing has elapsed.
- 13.11.5 If the test is concluded because no signs of combustion remain, remove the sample from the test room, measure its mass and record the extent of damage of each section.

13.11.6 Take a post-test photograph of the specimen. Note the extent of damage to the specimen after the test. Record the dimensions of burned areas and the depth of the burn on the cover fabric, interliner, if any, and filling of the seat, back, and arms. Record the post-test weight of the specimen. Before proceeding to additional tests, allow the test room to cool to the surrounding temperature, to within  $\pm 2^{\circ}\text{C}$  ( $\pm 5^{\circ}\text{F}$ ). Make sure all smoke is cleared. Check the readings of all instruments, and conduct additional tests only when the entire test system is ready.

## 14. Test Report

14.1 The test report shall contain all required information.

The following is recommended:

### 14.1.1 *Descriptive Information:*

- 14.1.1.1 Name and address of the testing laboratory.
- 14.1.1.2 Date and identification number of the report.
- 14.1.1.3 Name and address of the test requester.
- 14.1.1.4 Description of test room used.
- 14.1.1.5 Name of product manufacturer or supplier, if known.
- 14.1.1.6 Name or other identification marks and description of the product.
- 14.1.1.7 Density, or mass per unit surface area, total mass, thickness of the main components in the specimen, and mass of combustible portion of specimen, if known.
- 14.1.1.8 Description of the specimen, if different from the product.
- 14.1.1.9 Conditioning of the specimens.
- 14.1.1.10 Date of test.
- 14.1.1.11 Test number and any special remarks.

### 14.2 *Test Results:*

#### 14.2.1 *Table of Numerical Results Containing:*

- 14.2.1.1 Peak rate of heat release (in kW) and the time at which it occurred.
- 14.2.1.2 Total heat released (in MJ).
- 14.2.1.3 Peak rate of smoke release (in  $\text{m}^2 \text{s}^{-1}$ ) and the time at which it occurred.
- 14.2.1.4 Total smoke released (in  $\text{m}^2$ ).
- 14.2.1.5 Total mass loss (in kg).
- 14.2.1.6 Total percentage of mass loss (in %).
- 14.2.1.7 Peak concentration of carbon monoxide (in ppm).
- 14.2.1.8 Peak temperatures (in  $^{\circ}\text{C}$ ).
- 14.2.1.9 Equations used to calculate rate of heat release.
- 14.2.1.10 Peak optical density of smoke.
- 14.2.1.11 Average optical density of smoke, over the 10-minute period including the peak.
- 14.2.1.12 Total percentage of combustible mass loss (in %).
- 14.2.1.13 Average yield of carbon monoxide (in g CO/g fuel).
- 14.2.1.14 Average yield of carbon dioxide (in g  $\text{CO}_2$ /g fuel).
- 14.2.1.15 Carbon monoxide/carbon dioxide molar yield ratio.
- 14.2.1.16 Average yield of any other measured combustion gas (in g combustion gas/g fuel) (optional).
- 14.2.1.17 Report smoke obscuration, carbon monoxide, and temperature measurements in the room in the same fashion, if they have been made.

#### 14.2.2 *Graphical Results:*

- 14.2.2.1 Plot of rate of heat release versus time.
- 14.2.2.2 Plot of rate of smoke release versus time.
- 14.2.2.3 Plot of optical density versus time.
- 14.2.2.4 Plot of mass loss versus time.
- 14.2.2.5 Plot of concentration of carbon monoxide versus time.
- 14.2.2.6 Plot of concentration of carbon dioxide versus time.
- 14.2.2.7 Plots of concentration of any other measured combustion gas versus time.
- 14.2.2.8 Plot of mass flow rate in the exhaust duct versus time.



14.2.2.9 Plot of duct temperature versus time.

14.2.2.10 Report smoke obscuration, carbon monoxide, and temperature measurements in the room in the same fashion, if they have been made.

14.2.3 *Descriptive Results:*

14.2.3.1 Photographs and videotape of the fire development, and

14.2.3.2 Descriptive information, as suggested in 13.11.3.

## 15. Keywords

15.1 calorimetry; fire; full-scale test; heat release; oxygen consumption; smoke

## ANNEXES

### (Mandatory Information)

#### A1. CONSIDERATIONS FOR HEAT RELEASE MEASUREMENTS

A1.1 *Measurement of Rate of Heat Release by Oxygen Consumption:*

A1.1.1 *Introduction*—In 1917, Thornton (12) showed that for a large number of organic fuels, a more or less constant net amount of heat is released per unit of oxygen consumed for complete combustion. Huggett (1) obtained an average value for this constant of 13.1 MJ/kg of O<sub>2</sub>. This value may be used for practical applications and is accurate, with very few exceptions, to within  $\pm 5\%$ .

A1.1.2 Thornton's rule indicates that it is sufficient to measure the oxygen consumed in a combustion system in order to determine the net heat released. This is particularly useful for full-scale fire test applications. For example, for compartment fires, the oxygen consumption technique is much more accurate and easier to implement than methods based on measuring all the terms in a heat balance of the compartment.

A1.1.3 Perhaps the first application of the oxygen consumption principle in fire research was by Parker (13) using the Test Method E 84 (tunnel test). Later, Sensenig applied it to an intermediate scale room test (14). During the late seventies and early eighties, the O<sub>2</sub> consumption technique was refined at the National Institute for Standards and Technology (NIST, formerly National Bureau of Standards). A paper by Parker (15) gives equations to calculate rate of heat release by oxygen consumption for various applications. The technique is now used extensively in many laboratories all over the world, both in bench-scale (16) and full-scale (17–18) fire test applications.

A1.1.4 The objective of this section is to provide a comprehensive set of equations and guidelines to determine the rate of heat release in full-scale fire tests based on the O<sub>2</sub> consumption principle. The approach followed here is somewhat different from Parker (15) as the emphasis is on full-scale fire test applications and the use of volumetric flow rates is avoided. Volumetric flow rates require specification of temperature and pressure. Various investigators have used different combinations of reference pressure and temperature. This leads to confusion, which is minimized greatly if mass flow rates are used.

A1.1.5 The basic requirement is that all combustion products be collected in a hood and removed through an exhaust duct. At a distance downstream of the hood sufficient for adequate mixing, both flow rate and composition of the combustion gases are measured. It is assumed here that it is not

possible to measure the air flow rate into the system, as this is generally the case for full-scale fire tests. The differences in treatment and equations to be used are mainly due to the extent to which combustion gas analysis is made. In all cases oxygen shall be measured; however, heat release rate measurements will be more accurate by measuring CO<sub>2</sub> and CO additionally.

A1.1.6 It must be emphasized that the analysis is approximate. The following list describes the main simplifying assumptions made:

A1.1.6.1 The amount of energy released by complete combustion per unit of oxygen consumed is taken as:  $E = 13.1$  MJ/kg of O<sub>2</sub>.

A1.1.6.2 All combustion gases are considered to behave as ideal gases. In other words, one mole of any gas is assumed to occupy a constant volume at the same pressure and temperature.

A1.1.6.3 Incoming air consists of O<sub>2</sub>, CO<sub>2</sub>, H<sub>2</sub>O, and N<sub>2</sub>. Concentrations of all "inert" gases, which do not take part in the combustion reactions, are included with that of the nitrogen.

A1.1.6.4 O<sub>2</sub>, CO<sub>2</sub>, and CO are measured on a dry basis. In other words, water vapor is removed from the sample before combustion gas analysis measurements are made.

A1.1.7 In the analysis to follow, initial emphasis will be placed on the flow rate measurement. Equations to calculate flow rate are applicable, unless otherwise indicated, regardless of the configuration of the combustion gas analysis system. In subsequent sections, distinction is made between various combustion gas analyzer combinations.

#### A1.2 *Flow Measurements:*

A1.2.1 Two techniques are used most often to measure mass flow rate in the exhaust duct of full-scale fire tests. The velocity measurement technique (see A1.2.3) is the one most commonly used.

A1.2.2 The first technique measures mass flow rate via the pressure drop across, and temperature at, an orifice plate (Eq A2.1). If the test is conducted within a narrow range of conditions, the orifice-plate coefficient,  $C$ , is approximately constant. Determine the value of the orifice-plate coefficient using a gas burner calibration or an alternative method, which provides equivalent results; however, if flow rates are varied during a test or if temperature changes are considerable, the

effect on  $C$  of the Reynolds number and pressure at the downstream side of the orifice plate must be taken into account. Information on such corrections and on various design options, for example location of the pressure taps, are found in reference (19).

A1.2.3 The second technique is to measure velocity at one point in the duct, usually along the center line. The flow rate is then calculated using a predetermined shape of the velocity profile in the duct. The latter is obtained by measuring velocity at a sufficient number of representative points over the diameter or cross section of the duct prior to any fire tests. Detailed procedures for obtaining this profile are described in (20). Usually, conditions in full-scale fire tests are such that the flow in the duct is turbulent, resulting in a shape factor  $k_c$  (=ratio of the average velocity to the velocity along the centerline) close to 1.

A1.2.4 Due to considerable soot production in many fires, pitot static tubes cannot be used because of the potential for clogging of the holes. In order to deal with this problem, a more robust bidirectional probe was designed by McCaffrey and Heskestad (21). This involves measuring the differential pressure across the probe and the centerline velocity (Eq A2.2) and is valid in the range of Reynolds numbers,  $Re$ :

$$40 < Re < 3800. \quad (\text{A1.1})$$

A1.2.4.1 In many full scale fire test applications, duct diameter and flow rate are such that the Reynolds number is:

$$Re > 3800. \quad (\text{A1.2})$$

A1.2.4.2 In this case,  $f(Re)$  is taken as a constant (1.08), which greatly simplifies the calculations. In the system described the Reynolds number is usually greater than 3800, so that  $f(Re) = 1.08$ . Further details of this and of all other calculations discussed in this annex are found in a paper by Janssens (22). For additional details, see also ISO 9705.

*A1.3 Rate of Heat Release Measurement If Only Oxygen Concentration Measurements Are Used for Calculation:*

A1.3.1 In this case, all water vapor and  $\text{CO}_2$  are eliminated by the use of appropriate filtering media. This leads to the assumption that the sample combustion gas only consists of  $\text{O}_2$  and  $\text{N}_2$ . This is approximately true provided CO production is negligible. As the composition of the incoming air is unlikely to change during a test, and as the temperatures in building fires are usually not high enough to generate noticeable amounts of nitrogen oxides by nitrogen fixation, the mole fraction of  $\text{O}_2$  in the air as measured by the analyzer prior to a test is written on the basis of  $\text{O}_2$  and  $\text{N}_2$  exclusively. The mole fraction of  $\text{O}_2$  in the exhaust combustion gases, as measured by the oxygen analyzer, is written in a similar manner. As nitrogen is conserved and does not participate in the combustion reactions, the equations are derived on the basis of its conservation.

A1.3.2 In this case the rate of heat released (in kW) is calculated as a function of the heat released per unit of oxygen consumed ( $E$ , 13.1 MJ/kg of  $\text{O}_2$ ), the ratio of the molecular weight of oxygen ( $M_1$ , 32.0 kg/kmol) and the molecular weight of the incoming air ( $M_2$ , generally taken as 28.97 kg/kmol) and the mass flow rate of the incoming air (in kg/s). The flow rate measured is that of the smoke within the exhaust duct and not

that of the incoming air. In order to find a relation between the two it is necessary to define the oxygen depletion factor. The oxygen depletion factor is the fraction of the incoming air which is fully depleted of its oxygen (Eq A2.4). It has been demonstrated (see the appendix in Test Method E 1354), that the rate of heat release is a function of  $E$ ,  $M_1$ ,  $M_2$ , and the oxygen depletion factor, plus the expansion factor.

A1.3.2.1 The expansion factor value must be assigned. Use 1.105, the value for methane for tests. Other values are 1.084 (for propane), 1.0 (for carbon in dry air) and 1.21 (for hydrogen). Use 1.084 for calibrations made with propane gas.

A1.3.3 The resulting Eq A2.5, is expected to be accurate to within  $\pm 5\%$  provided combustion is complete. In other words, all the carbon is converted to  $\text{CO}_2$ . Errors will be larger if CO or soot production is considerable or if a significant amount of the combustion products are other than  $\text{CO}_2$  and  $\text{H}_2\text{O}$ . It is unlikely that these errors will be of concern for a single mattress test specimen.

*A1.4 Rate of Heat Release Measurement If Oxygen and Carbon Dioxide Concentration Measurements Are Used for Calculation:*

A1.4.1 This case is similar to that covered in the former section. It is now assumed that only water vapor is trapped before the sample reaches the combustion gas analyzers. Again, the equations, are derived on the basis of conservation of nitrogen. The mole fraction of  $\text{CO}_2$  in the incoming air is taken to be 440 ppm. A new equation is now needed for the oxygen depletion factor, Eq A2.7. Again the equation for rate of heat release (Eq A2.5) is accurate to within  $\pm 5\%$  provided combustion is complete. In other words, all the carbon is converted to  $\text{CO}_2$ .

*A1.5 Rate of Heat Release Measurement if Oxygen, Carbon Dioxide and Carbon Monoxide Concentration Measurements Are Used for Calculation:*

A1.5.1 This case reverts to that covered in A1.4 if CO production is negligible. Taking CO into account, however, changes the equations. It means that a new oxygen depletion factor is required, Eq A2.6, as well as, a new rate of heat release equation altogether, Eq A2.7.

*A1.6 Calculation of Heat Released by Igniting Fuel:*

A1.6.1 Part of the oxygen depletion in the exhaust duct is due to the combustion of the ignition source fuel. This part must be subtracted from the total oxygen depletion in order to determine the net rate of heat release of the test specimen.

A1.6.2 For a gas burner, Janssens has derived an equation to take into account this value (22). This equation is acceptable, but its use is accompanied by some difficulties, such as the delay in the response of the instrumentation in the exhaust duct, the problem of filling of an enclosure, and other experimental difficulties. A simpler alternative way of measuring the net heat released by the test specimen is to subtract from the heat obtained in the equations the heat release measured in the calibration. This heat yields a baseline rate of heat release curve.

*A1.7 Conclusions:*

A1.7.1 Depending on the configuration of combustion gas analyzers and the type of flow rate measurement, one of the following procedures shall be used to calculate rate of heat release.

A1.7.2 *Case 1*—Only O<sub>2</sub> concentration measurements are used.

A1.7.2.1 Calculate the mass flow rate of the exhaust combustion gases.

A1.7.2.2 Calculate the oxygen depletion factor.

A1.7.2.3 Calculate the rate of heat release.

A1.7.3 *Case 2*—Both O<sub>2</sub> and CO<sub>2</sub> concentration measurements are used.

A1.7.3.1 Calculate the mass flow rate of the exhaust combustion gases as in A1.7.2.

A1.7.3.2 Calculate the new oxygen depletion factor.

A1.7.3.3 Calculate the new rate of heat release.

A1.7.4 *Case 3*—O<sub>2</sub>, CO<sub>2</sub>, and CO concentration measurements are used.

A1.7.4.1 Calculate the mass flow rate of the exhaust com-

bustion gases as in A1.7.2.

A1.7.4.2 Calculate the new oxygen depletion factor.

A1.7.4.3 Calculate the new rate of heat release.

A1.7.5 If a CO<sub>2</sub> analyzer is used, this eliminates the need for removal of CO<sub>2</sub> from the combustion gas sample. This is mainly of practical importance as the scrubbing agent used to remove CO<sub>2</sub> usually requires careful handling and is rather expensive. If significant amounts of CO are produced, for example, at or beyond flashover in ventilation controlled room fires, accuracy of the rate of heat release measurement is improved if CO is measured.

A1.7.6 The presence of a water vapor analyzer simplifies the analysis and improves accuracy even more. Unfortunately, implementation of a water vapor analyzer is not straightforward because sampling lines, filters, etc., must be heated to avoid condensation; thus, the use of a water vapor analyzer precludes the need to estimate the expansion factor. For this test method, however, the use of water analyzers is not recommended.

## A2. MEASUREMENT EQUATIONS

A2.1 *Rate of Heat Release*—Symbols are explained in A2.4.

A2.1.1 *Flow Rate:*

A2.1.1.1 *Pressure Drop Measurement (Eq A2.1):*

$$\dot{m}_e = C * \sqrt{\left[\frac{\Delta p}{T_e}\right]} \quad (\text{A2.1})$$

A2.1.1.2 *Velocity Measurement (Eq A2.2):*

$$\dot{m}_e = 26.54 * \frac{A * k_c}{f(Re)} * \sqrt{\left[\frac{\Delta p}{T_e}\right]} \quad (\text{A2.2})$$

If Eq A2.2 is used, determine  $k_c$  whenever the bidirectional probe or the duct are replaced. Do this by correlating the velocity measured by the bidirectional probe with a reference method, such as a pitot-static tube.

A2.1.1.3 The function of the Reynolds number  $f(Re)$  has been described, by McCaffrey and Heskestad (21), as responding to Eq A2.3:

$$f(Re) = 1.533 - 1.366 \times 10^{-3} Re + 1.688 \times 10^{-6} Re^2 - 9.705 \times 10^{-11} Re^3 + 2.555 \times 10^{-13} Re^4 - 2.484 \times 10^{-17} Re^5 \quad (\text{A2.3})$$

A2.1.1.4 If  $Re > 3800$ , then  $f(Re) = 1.08$ .

A2.1.2 *Case 1*—Only O<sub>2</sub> concentration measurements are used. Calculate the rate of heat release in accordance with Eq A2.4:

$$\dot{Q}(t) = E \times 1.10 \times C \sqrt{\left[\frac{\Delta p}{T_e}\right]} \times \left[\frac{(X_{O_2}^\circ - X_{O_2})}{1.105 - 1.5 \times X_{O_2}^\circ}\right] \times (1 - X_{H_2O}^\circ) \quad (\text{A2.4})$$

Set the value of E for the test specimen equal to  $13.1 \times 10^3$  kJ/kg unless a more exact value is known for the test material.

A2.1.3 *Case 2*—Only O<sub>2</sub> and CO<sub>2</sub> concentration measurements are used. Calculate the mass flow rate in accordance with Eq A2.1 or Eq A2.2 and the oxygen depletion factor in accordance with Eq A2.5:

$$\phi = \frac{X_{O_2}^\circ \times [1 - X_{CO_2}] - X_{O_2} \times [1 - X_{CO_2}^\circ]}{X_{O_2}^\circ \times [1 - X_{O_2} - X_{CO_2}]} \quad (\text{A2.5})$$

and the rate of heat release in accordance with Eq A2.6:

$$\dot{Q}(t) = E \times \frac{\phi}{1 - \phi(\alpha - 1)} \times \dot{m}_e \times \frac{M_{O_2}}{M_a} \times (1 - X_{H_2O}^\circ - X_{CO_2}^\circ) \times X_{O_2}^\circ \quad (\text{A2.6})$$

A2.1.4 *Case 3*—O<sub>2</sub> and CO<sub>2</sub> and CO concentration measurements are used. Calculate the mass flow rate in accordance with Eq A2.1 or Eq A2.2 and the oxygen depletion factor in accordance with Eq A2.7:

$$\phi = \frac{X_{O_2}^\circ \times [1 - X_{CO_2} - X_{CO}] - X_{O_2} \times [1 - X_{CO_2}^\circ]}{X_{O_2}^\circ \times [1 - X_{O_2} - X_{CO_2} - X_{CO}]} \quad (\text{A2.7})$$

:

Finally calculate the rate of heat release according to Eq A2.8:

$$\dot{Q}(t) = \left[ E \times \phi - (E_{CO} - E) \times \frac{1 - \phi}{2} \times \frac{X_{CO}}{X_{O_2}} \right] \times \frac{\dot{m}_e}{1 + \phi \times (\alpha - 1)} \times \frac{M_{O_2}}{M_a} \times (1 - X_{H_2O}^\circ) \times X_{O_2}^\circ \quad (\text{A2.8})$$

A2.2 *Smoke Measurement Equations:*

A2.2.1 *Optical Density (OD) (Eq A2.9):*

$$OD = \log [I_o/I] \quad (\text{A2.9})$$

A2.2.2 *Extinction Coefficient (k) (Eq A2.10):*

$$k = (1/L_p) * \ln (I_o/I) \quad (\text{A2.10})$$

A2.2.2.1 The volumetric flow rate is calculated as the ratio of the mass flow rate and the density of air, at the corresponding temperature; thus, both the volumetric flow and the density of air must undergo temperature corrections. The volumetric duct flow rate ( $V$ ) is adjusted because it is measured in the exhaust duct, but required at the temperature near the photo-detector, as shown in (Eq A2.11):



$$\dot{V}_s = \dot{V}_e * \left( \frac{T_s}{T_e} \right) \quad (\text{A2.11})$$

A2.2.2.2 The density of air is adjusted between the literature value, measured at 273.15 K, and the value at the temperature in the exhaust duct, as shown in (Eq A2.12):

$$\rho = \rho_o * \frac{273.15}{T_e} \quad (\text{A2.12})$$

Then, the final equation for the volumetric flow rate is Eq A2.13:

$$\dot{V}_s = \frac{\dot{m}_e}{\rho_o} * \frac{T_e}{273.15} \quad (\text{A2.13})$$

Rate of smoke release (RSR) is defined by Eq A2.14:

$$\text{RSR} = [\dot{V}_s * k] \quad (\text{A2.14})$$

Total smoke released (TSR) is defined by Eq A2.15:

$$\text{TSR} = \int \text{RSR} \, dt \quad (\text{A2.15})$$

### A2.3 Gas Yield Measurement Calculations:

A2.3.1 Calculate the gas yields ( $f$ ) using the following equation (Eq A2.16):

$$f_x = \frac{\int \text{mass flow rate of gas}_x \, dt}{\text{mass loss of test specimen}} \quad (\text{A2.16})$$

A2.3.2 The numerator in this equation is calculated by adding the product of the fraction of combustion gas by the total mass flow rate, measured at each scan, multiplying it by the total time period involved and dividing by the number of scans, as shown in Eq A2.17:

$$f_x = \frac{(\sum_i ([x]_i * \dot{m}_{e(i)} * \Delta t_i)) * 0.001 * \frac{M_x}{M_a}}{\text{mass loss of test specimen}} \quad (\text{A2.17})$$

A2.3.3 In this equation,  $[x]$ , the concentration of gas  $x$ , is expressed in ppm,  $\dot{m}_e$ , the mass flow rate, calculated by Eq A2.1 or Eq A2.2, is expressed in kg/s,  $M_x$  is the molecular weight of gas species  $x$ ,  $M_a$  is the molecular weight of exhaust air (29 kg/kmol),  $\Delta t$  is the scan period and mass loss of specimen is the mass lost over the period over which the gas yield is calculated, and is expressed in g, with 0.001 a conversion factor, to account for the unit changes.

A2.3.4 Report gas concentrations on a dry gas basis, unless water concentrations are being measured.

### A2.4 Symbols:

$A$	= cross sectional area of duct (in $\text{m}^2$ )
$C$	= orifice plate coefficient (in $\text{kg}^{1/2} \text{m}^{1/2} \text{K}^{1/2}$ )
$E$	= net heat released for complete combustion, per unit of oxygen consumed (13 100 kJ/kg $\text{O}_2$ )
$E_{CO}$	= net heat released for complete combustion per unit of oxygen consumed, for CO (17 600 kJ/kg $\text{O}_2$ )
$f(Re)$	= Reynolds number correction (non dimensional)
$f_x$	= yield of gas $x$ (in g/g)
$I$	= light intensity for a parallel light beam having traversed a certain length of smoky environment and reaching photodetector (nondimensional)

$I_O$	= light intensity for a beam of parallel light rays, measured in a smoke-free environment, with a detector having the same spectral sensitivity as the human eye and reaching the photodetector (nondimensional)
$k$	= extinction coefficient (in L/m)
$k_c$	= velocity profile shape factor (nondimensional)
$L_p$	= light path length of beam through smoky environment (in m)
$\dot{m}_e$	= mass flow rate in exhaust duct (in kg/s)
$\dot{m}_e$	= $C (\rho/T_e)^{1/2}$ (mass flow rate, by measurement of pressure drop, in kg/s, according to Eq A2.1)
$\dot{m}_e$	= $(26.54 \times A \times k_c / (f(Re))) \times (\alpha/T_e)^{1/2}$ (mass flow rate, by measurement of velocity drop, in kg/s, according to Eq A2.2)
$M_a$	= molecular weight of incoming and exhaust air (29 kg/kmol)
$M_{CO}$	= molecular weight of carbon monoxide (28 kg/kmol)
$M_{CO_2}$	= molecular weight of carbon dioxide (44 kg/kmol)
$M_{H_2O}$	= molecular weight of water (18 kg/kmol)
$M_{N_2}$	= molecular weight of nitrogen (28 kg/kmol)
$M_{O_2}$	= molecular weight of oxygen (32 kg/kmol)
$OD$	= optical density (nondimensional)
$\Delta P$	= pressure drop across the orifice plate or bidirectional probe (in Pa)
$\dot{Q}(t)$	= heat release rate, as a function of time (in kW)
$RSR$	= rate of smoke release (in $\text{m}^2/\text{s}$ )
$T_e$	= combustion gas temperature at the orifice plate (in K)
$T_s$	= combustion gas temperature (near photodetector) (in K)
$TSR$	= total smoke released (in $\text{m}^2$ )
$V_e$	= volumetric flow rate in exhaust duct (at measuring location of mass flow rate) (in $\text{m}^3/\text{s}$ )
$V_s$	= volumetric flow rate at location of smoke meter (value adjusted for smoke measurement calculations) (in $\text{m}^3/\text{s}$ )
$[x]$	= concentration of gas $x$ (in ppm)
$X_{CO}$	= measured mole fraction of CO in exhaust flow (nondimensional)
$X_{CO_2}$	= measured mole fraction of $\text{CO}_2$ in exhaust flow (nondimensional)
$X_{H_2O}^\circ$	= measured mole fraction of $\text{H}_2\text{O}$ in incoming air (nondimensional)
$X_{O_2}$	= measured mole fraction of $\text{O}_2$ in exhaust flow (nondimensional)
$X_{O_2}^\circ$	= measured mole fraction of $\text{O}_2$ in incoming air (nondimensional)
$\alpha$	= Combustion expansion factor (nondimensional; normally a value of 1.105)
$\rho$	= density of air at the temperature in exhaust duct (in $\text{kg}/\text{m}^3$ )
$\rho_o$	= density of air at 273.15 K (1.293 $\text{kg}/\text{m}^3$ )
$\phi$	= oxygen depletion factor (nondimensional)

## APPENDIXES

### (Nonmandatory Information)

#### X1. METHOD OF DETERMINING SUITABILITY OF OXYGEN ANALYZERS FOR MAKING HEAT RELEASE MEASUREMENTS

X1.1 *General*—The type of oxygen analyzer best suited for fire gas analysis is of the paramagnetic type. Electrochemical analyzers or analyzers using zirconia sensors generally have been found not to have adequate sensitivity or suitability for this type of work. The normal range of the instrument to be used is 0 to 25 volume % oxygen. The linearity of paramagnetic analyzers, normally, is better than can be checked by a user laboratory; thus, verifying their linearity is not necessary. It is important, however, to confirm the noise and short-term drift of the instrument used.

##### X1.2 *Procedure:*

X1.2.1 Connect two different gas bottles having approximately two percentage points apart, for example, 15 volume % and 17 volume %, to a selector valve at the inlet of the analyzer.

X1.2.2 Connect the electrical power and let the analyzer warm up for 24 h, with one of the test gases from X1.2.1 flowing through it.

X1.2.3 Connect a data acquisition system to the output of the analyzer. Quickly switch from the first gas bottle to the second bottle, and immediately start collecting data, taking one data point per second. Collect data for 20 minutes.

X1.2.4 Determine the drift by using a least-squares analysis fitting procedure to pass a straight line through the last 19

minutes of data. Extrapolate the line back through the first minute of data. The difference between the readings at 0 minutes and at 20 minutes on the fitted straight line represents the short-term drift. Record the drift in units of parts per million of oxygen.

X1.2.5 The noise is represented by the root-mean-square deviation around the fitted straight line. Calculate that root-mean-square value and record it in units of parts per million of oxygen.

X1.2.6 The analyzer is suitable for use in heat release measurements if the sum of the drift plus the noise terms is  $\leq 50$  ppm oxygen (note that both terms must be expressed as positive numbers).

X1.3 *Additional Precautions*—A paramagnetic oxygen analyzer is directly sensitive to barometric pressure changes at its outlet port and to flow rate fluctuations in the sample supply stream. It is essential that the flow rate be regulated. Use either a flow rate regulator of the mechanical diaphragm type, or an electronic mass flow rate controller. In order to protect against errors due to changes in barometric pressure, one of the following procedures should be used: control the back pressure to the analyzer with a back pressure regulator of the absolute-pressure type, or electrically measure the actual pressure at the detector element and provide a signal correction for the analyzer output.

#### X2. BURNING OF OXIDIZERS

X2.1 If the fuel contains large proportions of oxidizers, oxygen consumption calorimetry alone is not adequate for measurement of heat release, since there will be oxygen formation as a consequence of the thermal decomposition of the oxidizers.

X2.2 In such cases, it is advisable to use a combination of techniques to assess heat release. Such techniques may include thermal measurements or calculations based on the stoichiometry of the oxidizing fuels consumed. The information about

the techniques used and the calculation should be reported.

X2.3 If there is reason to believe that the material to be used as a fuel will behave differently from standard materials or products in terms of the oxygen consumption constant, particular care should be taken before using the computational methods in this practice. It is recommended that a specific oxygen consumption constant be used for that material or product.

#### X3. ENVIRONMENTAL PROTECTION

X3.1 A suitable environmental system for removal of soot and other hazardous combustion products before exhausting to the atmosphere is usually required. Various methods are available, such as mechanical filtration, scrubbers, or after-burners. The choice of a system depends on factor, such as local environmental regulations, cost of the system, frequency of testing, and intensity of fires that are expected to be

experienced in the burn facility. The selection of any particular system is left to the discretion of the laboratories; however, the exhaust removal system shall be capable of fulfilling the requirements of the test method throughout the entire test. The choice of an environmental or smoke abatement system, therefore, shall not compromise the scientific intent of the test method.

X3.2 One system found suitable is a mechanical filtering system. The system consists of three stages of filters. The first two stages use a set of disposable furnace filters and a set of bag filters. These filters remove most of the soot and other large or coarse particles. The third stage consists of filters that remove fine particles of up to 5 µm. The first two stages of filters need to be replaced frequently to maintain sufficient flow through the exhaust system. Pressure gages are installed in

every stage to indicate the pressure differential across the filters. The differential pressure increases as filters get clogged. Replace the filters whenever there is insufficient flow of air through the system.

X3.3 An afterburner is a more efficient system, which also will help minimize variations in the exhaust flow rate throughout the entire test.

## REFERENCES

- (1) Huggett, C., "Estimation of Rate of Heat Release by Means of Oxygen Consumption Measurements, Fire and Materials," Vol 4, 1980, pp. 61–65.
- (2) Coaker, A.W., Hirschler, M.M., Shakir, S. and Shoemaker, C.L., "Flammability Testing of New Vinyl Compounds with Low Flammability and Low Smoke Release in Cables," Proc. 39th Int. Wire and Cable Symposium, Nov. 13–15, Reno, NV, p. 643–54, U.S. Army CECOM, Fort Monmouth, NJ, 1990.
- (3) Coaker, A.W., Hirschler, M.M., and Shoemaker, C.L., "Rate of heat release testing for vinyl wire and cable materials with reduced flammability and smoke. Full scale cable tray tests and small scale tests," *Fire Safety J.*, Vol 19, 19–53 (1992).
- (4) Hirschler, M.M., "Survey of fire testing of electrical cables," M.M. Hirschler, *Fire and Materials*, Vol 16, 107–18 (1992).
- (5) Ostman, B., "Comparison of Smoke Release from Building Products," Int. Conf. FIRE. Control the Heat...Reduce the Hazard, London, UK, 24–25 Oct. 1988, Fire Research Station, UK, paper 8.
- (6) Mikkola, E. (VTT, Finland), First Int. Cone Calorimeter Users' Seminar and Workshop, London, UK, Jan. 19, 1990.
- (7) Finley, G., Janssens, M.L. and Hirschler, M.M., "Room Fire Testing: Recent Experiences and Implications," in Proc. Fire and Materials '99, 6th Int. Conf., Feb. 22–23, 1999, San Antonio, TX, Interscience Commun., London, UK, pp. 83–94 (1999).
- (8) Hirschler, M.M. and Janssens, M.L., "Smoke Obscuration Measurements in the NFPA 265 Room-Corner Test," in Proc. Fire and Materials '99, 6th Int. Conf. Feb. 22–23, 1999, San Antonio, TX, Interscience Commun., London, UK, pp. 179–98 (1999).
- (9) Hirschler, M. M., "How to Measure Smoke Obscuration in a Manner Relevant to Fire Hazard Assessment: Use of Heat Release Calorimetry Test Equipment," *J. Fire Sciences*, Vol 9, 1991, pp. 183–222.
- (10) Tran, H., "Experimental Data on Wood Materials," Chapter 11 b, *Heat Release in Fires*, Elsevier, London, UK, V. Babrauskas and S. J. Grayson, Eds., pp. 357–372, 1992.
- (11) Hirschler, M. M., "Heat Release from Plastics," Chapter 12 a, *Heat Release in Fires*, Elsevier, London, UK, V. Babrauskas and S. J. Grayson, eds., pp. 375–422, 1992.
- (12) W. Thornton, "The Relation of Oxygen to the Heat of Combustion of Organic Compounds," *Philosophical Magazine and J. of Science*, Vol 33, No. 196, 1917.
- (13) W. Parker, "An Investigation of the Fire Environment in the ASTM E-84 Tunnel Test," NBS Technical Note 945, 1977.
- (14) D. Sensenig, "An Oxygen Consumption Technique for Determining the Contribution of Interior Wall Finishes to Room Fires," NBS Technical Note 1182, 1980.
- (15) W. Parker, "Calculations of the Heat Release Rate by Oxygen Consumption for Various Applications," NBSIR 812-2427-1, 1982.
- (16) V. Babrauskas, "Development of the Cone Calorimeter—A Bench-Scale Rate of Heat Release Apparatus Based on Oxygen Consumption," NBSIR 82-2611, 1982.
- (17) V. Babrauskas, J. Lawson, W. Walton and W. Twilley, "Upholstered Furniture Heat Release Rates Measured with the Furniture Calorimeter," NBSIR 82-2604, 1083.
- (18) ASTM, "Proposed Method for Room Fire Test of Wall and Ceiling Materials and Assemblies," *Annual Book of ASTM Standards*, Vol 04.07, 1983.
- (19) ASME, "Fluid Meters—Their Theory and Applications," *Report of the ASME Committee on Fluid Meters*, H. Bean, Ed., Sixth Edition, 1971.
- (20) E. Ower and R. Pankhurst, "The Measurement of Air Flow," Pergamon Press, 5th Edition, pp. 112–147, 1977.
- (21) B. McCaffrey and G. Heskestad, *Combustion and Flame*, Vol 26, pp. 125–127, 1976.
- (22) M.L. Janssens, "Measuring Rate of Heat Release by Oxygen Consumption," *Fire Technology*, Vol 27, pp. 234–49, (1991).

*ASTM International takes no position respecting the validity of any patent rights asserted in connection with any item mentioned in this standard. Users of this standard are expressly advised that determination of the validity of any such patent rights, and the risk of infringement of such rights, are entirely their own responsibility.*

*This standard is subject to revision at any time by the responsible technical committee and must be reviewed every five years and if not revised, either reapproved or withdrawn. Your comments are invited either for revision of this standard or for additional standards and should be addressed to ASTM International Headquarters. Your comments will receive careful consideration at a meeting of the responsible technical committee, which you may attend. If you feel that your comments have not received a fair hearing you should make your views known to the ASTM Committee on Standards, at the address shown below.*

*This standard is copyrighted by ASTM International, 100 Barr Harbor Drive, PO Box C700, West Conshohocken, PA 19428-2959, United States. Individual reprints (single or multiple copies) of this standard may be obtained by contacting ASTM at the above address or at 610-832-9585 (phone), 610-832-9555 (fax), or service@astm.org (e-mail); or through the ASTM website (www.astm.org).*