



Standard Test Method for Measurement of Mass Loss and Ignitability for Screening Purposes Using a Conical Radiant Heater¹

This standard is issued under the fixed designation E 2102; the number immediately following the designation indicates the year of original adoption or, in the case of revision, the year of last revision. A number in parentheses indicates the year of last reapproval. A superscript epsilon (ϵ) indicates an editorial change since the last revision or reapproval.

INTRODUCTION

The screening fire-test-response method described in this standard uses a radiant energy source similar to that used in the cone calorimeter, Test Method E 1354. However, the test method apparatus is much simpler, because it excludes measurements of oxygen consumption or of smoke obscuration, which are incorporated into the cone calorimeter to measure heat and smoke release. A fire-test-response standard describes a test method from which one or more fire-test-response characteristics can be measured, as a result of exposure to a prescribed source of heat or flame, under controlled conditions. There are many occasions, typically for initial research and development, when there is a need for screening samples of materials, products, or assemblies, using a simple test. This allows the user to verify whether certain fire-test-response characteristics of the sample fall within the expected margins. Screening tests, as related to fire, are described in fire terminology as fire-response tests performed to determine whether a material, product, or assembly (a) exhibits any unusual fire-related characteristics, (b) has certain expected fire-related characteristics, or (c) is capable of being preliminarily categorized according to the fire characteristic in question. Screening tests addressing fire properties should be chosen so that the energy input (as heat or flame) is representative of that in the fire test method for which screening is desired.

1. Scope

1.1 This fire-test-response standard provides a means of measuring mass loss and ignitability, for screening purposes, from essentially planar materials, products, or assemblies (including surface finishes), exposed to controlled levels of radiant heating, with or without an external ignitor. This test method is intended for screening purposes only.

1.2 The principal fire-test-response characteristics obtained from this test method are those associated with mass loss from the specimens tested, as a function of time. Time to sustained flaming is also determined. Heat release is, optionally, determined using thermopile measurements detailed in Annex A2.

1.2.1 The fire-test-response characteristics obtained from this test are best used for comparisons between materials with some similarities in composition or structure.

1.3 The relationship between mass loss and heat release depends on the material, product, or assembly tested, and no universal formula exists for calculation of heat release using mass loss measurements (see also additional limitations in 5.7).

1.4 The fire-test-response characteristics obtained from this test method are also obtainable with the apparatus used in Test Method E 1354 (the cone calorimeter) or in an applications standards of that equipment (see also 5.4). The referenced test methods permit measurements of added fire-test-response characteristics.

1.5 The fire-test-response characteristics obtained by this test method are specific to the specimen tested, in the form and thickness tested, and are not an inherent property of the material, product, or assembly.

1.6 This fire-test-response method does not provide information on the fire performance of the test specimens under fire conditions other than those conditions specified in this test method. For additional limitations of this test method, see 5.7.

1.7 Use the SI system of units in referee decisions; see IEEE/ASTM SI-10. The units given in parentheses are for information only.

1.8 This standard is used to measure and describe the response of materials, products, or assemblies to heat and flame under controlled conditions, but does not by itself incorporate all factors required for fire hazard or fire risk assessment of the materials,

¹ This test method is under the jurisdiction of ASTM Committee E05 on Fire Standards and is the direct responsibility of Subcommittee E05.21 on Smoke and Combustion Products.

Current edition approved February April 1, 2004. Published March April 2004. Originally approved in 2000. Last previous edition approved in 2000 as E 2102 - 00.

products, or assemblies under actual fire conditions.

1.9 Fire testing of products and materials is inherently hazardous, and adequate safeguards for personnel and property shall be employed in conducting these tests. This test method may involve hazardous materials, operations, and equipment. See also Section 7.

1.10 *This standard does not purport to address all of the safety concerns, if any, associated with its use. It is the responsibility of the user of this standard to establish appropriate safety and health practices and determine the applicability of regulatory limitations prior to use.*

2. Referenced Documents

2.1 ASTM Standards:²

- D 5537 Test Method for Heat Release, Flame Spread and Mass Loss Testing of Insulating Materials Contained in Electrical or Optical Fiber Cables When Burning in a Vertical Cable Tray Configuration
- D 6113 Test Method for Using a Cone Calorimeter to Determine Fire-Test-Response Characteristics of Insulating Materials Contained in Electrical or Optical Fiber Cables
- E 176 Terminology of Fire Standards
- E 535 Practice for Preparation of Fire-Test-Response Standards
- E 603 Guide for Room Fire Experiments
- E 638 Test Method for Calibration of Heat Transfer Rate Calorimeters Using a Narrow-Angle Blackbody Radiation Facility
- E 906 Test Method for Heat and Visible Smoke Release Rates for Materials and Products
- E 1354 Test Method for Heat and Visible Smoke Release Rates for Materials and Products Using an Oxygen Consumption Calorimeter
- E 1474 Test Method for Determining the Heat Release Rate of Upholstered Furniture and Mattress Components or Composites Using a Bench Scale Oxygen Consumption Calorimeter
- E 1537 Test Method for Fire Testing of Real Scale Upholstered Furniture
- E 1590 Test Method for Fire Testing of Real Scale Mattresses
- E 1623 Test Method for Determining Fire and Thermal Parameters of Materials, Products and Systems Using an Intermediate Scale Calorimeter (ICAL)
- E 1740 Test Method for Determining the Heat Release Rate and Other Fire-Test-Response Characteristics of Wallcovering Composites Using a Cone Calorimeter
- E 1822 Test Method for Fire Testing of Real Scale Stacked Chairs
- IEEE/ASTM SI-10, International System of Units (SI) The Modernized Metric System

2.2 ISO Standards:³

- ISO 3261 Fire Tests—Vocabulary
- ISO 5657, Fire Tests—Reaction to Fire—Ignitability of Building Products
- ISO 5660-1 Fire Tests—Reaction to Fire—Rate of Heat Release from Building Products (Cone calorimeter method)
- ISO 9705 Fire Tests—Full Scale Room Test for Surface Products
- ISO 13943 Fire Safety Vocabulary

2.3 British Standards:⁴

- BS 476, Part 15, Fire Tests—Reaction to Fire—Rate of Heat Release from Building Products (Cone calorimeter method)
- BS 6809 Method of Calibration of Radiometers for Use in Fire Testing

3. Terminology

3.1 *Definitions:* For definitions of terms used in this test method refer to the terminology contained in Terminology E 176, ISO 3261 and ISO 13943. In case of conflict, the definitions given in Terminology E 176 shall prevail.

3.2 *Definitions of Terms Specific to This Standard:*

- 3.2.1 *assembly, n*—a unit or structure composed of a combination of materials or products, or both.
- 3.2.2 *composite, n*—a combination of materials which are generally recognized as distinct entities, for example coated or laminated materials.
- 3.2.3 *continuous* (as related to data acquisition), *adj*—conducted at data collection intervals of 5 s or less.
- 3.2.4 *essentially flat surface, n*—surface where the irregularity from a plane does not exceed ± 1 mm.
- 3.2.5 *exposed surface, n*—that surface of the specimen subjected to the incident heat.
- 3.2.6 *flashing, n*—existence of flame on or over the surface of the specimen for periods of less than 1 s.

² For referenced ASTM standards, visit the ASTM website, www.astm.org, or contact ASTM Customer Service at service@astm.org. For *Annual Book of ASTM Standards* volume information, refer to the standard's Document Summary page on the ASTM website.

³ Available from International Standardization Organization, P.O. Box 56, CH-1211; Geneva 20, Switzerland or American National Standards Institute (ANSI), 25 W. 43rd St., 4th Floor, New York, NY 10036.

Available from .

⁴ Available from British Standards Institution, PO Box 4033, Linford Wood, Milton Keynes, MK 14 6LE, United Kingdom

3.2.7 *irradiance* (at a point of a surface), *n*—ratio of the radiant flux incident on a small but measurable element of surface containing the point, by the area of that element.

3.2.7.1 *Discussion*—Convective heating is negligible in the horizontal specimen orientation. In the vertical orientation, it is small, but not negligible. Despite this contribution from convective heating, the term “irradiance” is used instead of “heat flux” throughout this test method as it best indicates the essentially radiative mode of heat transfer.

3.2.8 *material*, *n*—single substance, or uniformly dispersed mixture, for example metal, stone, timber, concrete, mineral fiber, or polymer.

3.2.9 *orientation*, *n*—the plane in which the exposed face of the specimen is located during testing.

3.2.9.1 *Discussion*—For this standard, the specimen orientation may only be either vertical or horizontal.

3.2.10 *sample*, *n*—an amount of the material, product, or assembly, to be tested, which is representative of the item as a whole.

3.2.11 *specimen*, *n*—representative piece of the product which is to be tested together with any substrate or treatment.

3.2.11.1 *Discussion*—This may include an air gap.

3.2.12 *sustained flaming*, *n*—the existence of flame on or over the surface of the specimen for a period of 4 s or more.

3.2.13 *time to ignition*, *n*—time between the start of the test and the presence of a flame on or over most of the specimen surface for a period of at least 4 s.

3.2.14 *time to sustained flaming*, *n*—time to ignition.

3.2.15 *transitory flaming*, *n*—the existence of flame on or over the surface of the specimen for periods of between 1 and 4 s.

4. Summary of Test Method

4.1 This test method employs a conically-shaped electrically-heated radiant-energy source, positioned so as to produce an irradiance level of up to 100 kW/m², averaged over the center of the exposed surface of an essentially planar specimen. An external spark ignitor is available, if required. This test method is used to determine continuously the mass lost during the combustion process, using a load cell, for screening purposes. Ignitability is also assessed by the test method.

4.1.1 Optionally, the test method is capable of obtaining an estimate of the heat released by the specimen during the burning process, using a thermopile housed above the burning specimen (See Annex A2). Determinations of heat release using a similar radiant-energy source and oxygen consumption calorimetry, are made with the cone calorimeter, Test Method E 1354.

4.2 The specimen is essentially planar, 100 mm by 100 mm [3.9 by 3.9 in.] in size, at a thickness not exceeding 25 mm [1 in.] and is mounted within a holder.

5. Significance and Use

5.1 This test method provides a means for screening materials, products, or assemblies, for the mass loss, and ignitability they exhibit under specified heat flux exposure conditions. As an option, the test method is also suitable for screening for the heat released, by using a thermopile method (See Annex A2).

5.1.1 Terminology E 176, on fire standards, states that fire-test-response characteristics include ease of ignition and mass loss (both measured in this test method), as well as flame spread, smoke generation, fire endurance, and toxic potency of smoke.

5.1.2 The mass loss rate of a material, product, or assembly is a fire-test-response characteristic that gives an indication of its burning rate. Thus, a lower mass loss rate is often associated with slower burning. Note, however, that mass loss is not always a result of combustion, and that this method does not assess release of smoke or combustion products.

5.1.3 The time to ignition of a material, product, or assembly is a fire-test-response characteristic that gives an indication of its propensity to ignite at the applied heat flux level and subsequently to release heat and spread flame over its surface. Thus, a longer time to ignition is an indication of a lower propensity for the material, product, or assembly to become involved and contribute to fire spread or growth; however this method does not assess the smoke or combustion products released.

5.1.4 The apparatus used for this test method is suitable to assess the critical heat flux for ignition of the materials, products, or assemblies tested, by assessing ignitability at various heat fluxes (see Appendix X3 for guidance).

5.2 Values determined by this test are specific to the specimen in the form and thickness tested and are not inherent fundamental properties of the material, product, or assembly tested. Thus, closely repeatable or reproducible experimental results are not to be expected from this test method when tests are conducted for a given material, product, or assembly, while introducing variations in properties such as specimen thickness or density.

5.3 No incident irradiance is specified in this test method. The instrument is capable of generating irradiances ranging up to 100 kW/m². The choice of irradiance is a function of the application of the material, product, or assembly to be tested, and of the fire scenario the user is investigating. However, the method is not suitable for incident irradiances below 10 kW/m² (see 5.7.3).

5.4 The method used for optionally measuring heat release, a thermopile, is not as accurate as the conventional oxygen consumption calorimetry method, used in the cone calorimeter, Test Method E 1354, in its applications standards, such as Test Method E 1474 and E 1740, or in intermediate scale or a large scale calorimetry test methods, such as Test Methods E 1623, E 1537, E 1590 or D 5537 (see also Annex A2). On the other hand the thermopile method of assessing heat release has been used extensively because of its simplicity, including Test Method E 906, and other applications discussed in Guide E 603.⁵

⁵ Note that this section refers to accuracy of measurement, and not to precision. The precision of this test method has not yet been determined.

5.5 Testing of composites and dimensionally unstable materials requires special procedures (see 8.4 and 8.5).

5.6 Testing in the vertical orientation is feasible with the test method, but not recommended, as it has been shown to have the potential to lead to serious measurement errors on time to ignition.

5.7 *Limitations*

5.7.1 No universal formula exists for calculation of heat release as a function of mass loss. If heat release data are desired, calibration curves must be developed by the user, and they are specific to the material, product, or assembly tested.

5.7.2 If during the test of one or more of the three replicate test specimens, any of the following unusual behavior occurs: (1) molten material overflows the specimen holder trough, (2) one or more portions of a test specimen is forcefully displaced from the zone of controlled irradiance (explosive spalling); or (3) the test specimen swells sufficiently prior to ignition to touch the spark plug or swells up to the plane of the heater base during combustion; the test is invalid. Then test an additional specimen of the identical preconditioned test specimens in the test mode in which the unusual behavior occurred. Do not incorporate data obtained from the tests noted above, yielding inadequate results, in the averaged data but report the occurrence. The test method is not suitable if more than three out of six test specimens tested show any of the above characteristics.

5.7.3 The applicability of this test method to smoldering ignition has not been demonstrated. This test method is not suitable for incident irradiances below 10 kW/m².

5.7.4 The validity of the results of this test method for a particular scenario depends on the conditions under which the tests are conducted. In particular, it has been established that the use of a different irradiance will change relative results

5.7.5 The thermopile readings, if used, are likely not to be reflective of the heat output of the burning specimen if the flames extend to the thermopile.

5.8 In this procedure, the specimens are subjected to one or more specific sets of laboratory test conditions. If different test conditions are substituted or the end-use conditions are changed, it is not always possible by or from this test method to predict changes in the fire-test-response characteristics measured. Therefore, the results are valid only for the fire test exposure conditions described in this procedure.

NOTE 1—This statement is required for all fire-test-response standards by Practice E 535.

6. Apparatus and Ancillary Equipment

6.1 *General.* The apparatus shall consist essentially of the following components: a conically-shaped radiant heater, a load cell, a specimen holder and an exhaust system. A schematic representation of the apparatus is given in Fig. 1. The individual components are described in sections 6.2-6.11. Unless otherwise stated, dimensions specified as critical shall have a tolerance of ±1 mm [0.04 in.]. All other dimensions are only recommended values.

6.2 *Conically-Shaped Radiant Electrical Heater.* The active element of the heater shall consist of an electrical heater rod, capable of delivering 5000 W at the operating voltage, tightly wound into the shape of a truncated cone (see Fig. 2). The heater shall be encased on the outside with a double-wall stainless steel⁶ cone, filled with a refractory blanket of nominal thickness 13 mm [0.5 in.] and nominal density 100 kg/m³ [6 lb/ft³]. The irradiance from the heater shall be maintained at a preset level by controlling the average temperature of three type K, stainless steel sheathed thermocouples, symmetrically disposed and in contact

⁶ Stainless steel can be replaced by a different alloy that offers at least the same protection to hot and corrosive environments.

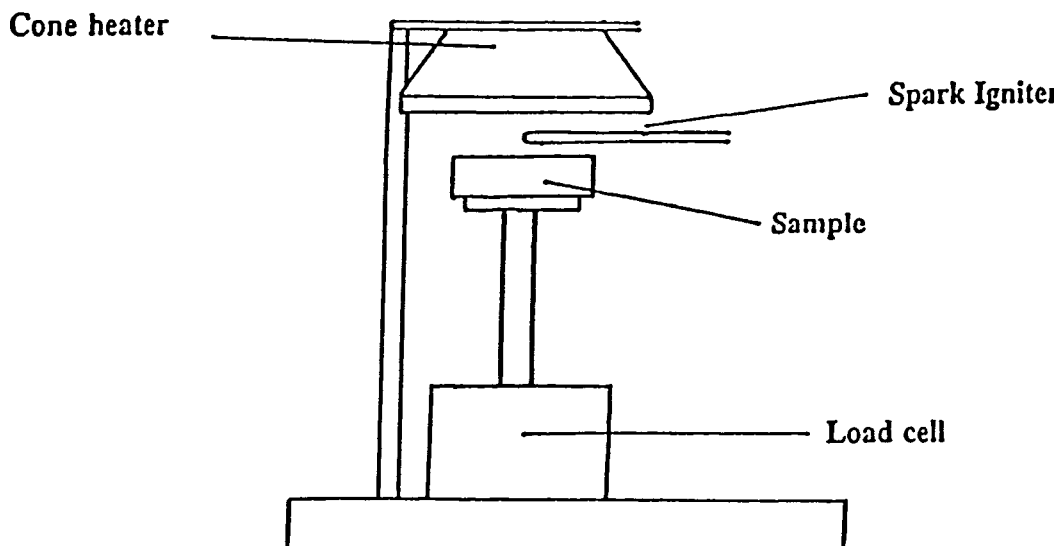

FIG. 1 Schematic of Apparatus

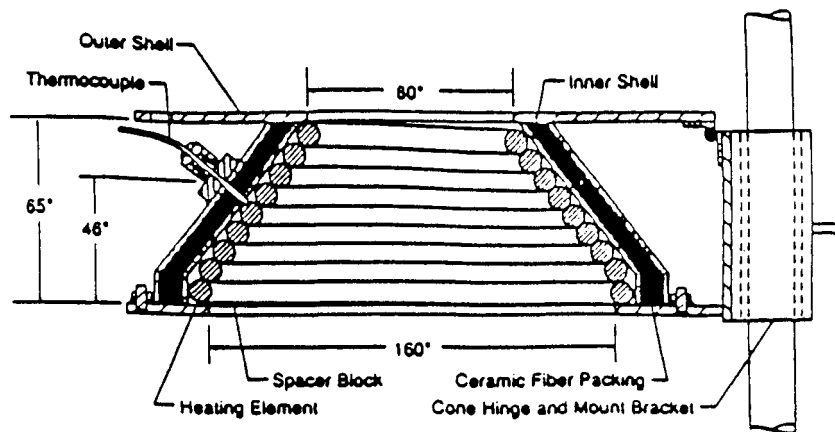

FIG. 2 Cross-Section View Through the Heater

with, but not welded to, the heater element (see Fig. 2). The thermocouples to be used shall be either 3 mm [0.12 in.] outside diameter sheathed thermocouples with exposed hot junction or 1.0 to 1.6 mm [0.04 to 0.06 in.] outside diameter sheathed thermocouples with unexposed hot junction. The heater shall be capable of producing irradiances on the surface of the specimen of up to 100 kW/m². The irradiance shall be uniform within the central 50 by 50 mm [2 by 2 in.] area of the exposed specimen surface, to within $\pm 2\%$.

6.2.1 The cone heater shall be provided with a removable radiation shield to protect the specimen from irradiance immediately prior to the start of the test. The shield shall protect the specimen so that the irradiance to the specimen in its presence is decreased by 90% within 10 s and that the irradiance after shield withdrawal does not differ by more than 1 kW/m² from the value calibrated. The radiation shield shall be made of non-combustible material, with a total thickness not to exceed 12 mm. The radiation shield shall comply with either 6.2.1.1 or 6.2.1.2 and shall be kept in place for a maximum period of 10 s.⁷

6.2.1.1 A water-cooled radiation shield coated with a durable matte black finish of surface emissivity $e = 0.95 \pm 0.05$ (Type I Shield); or

6.2.1.2 A radiation shield with a reflective top surface in order to minimize radiation transfer, but not water-cooled (Type II Shield).

6.2.1.3 The radiation shield shall be equipped with a handle or other suitable means for quick insertion and removal. The cone heater base plate shall be equipped with the means for holding the radiation shield in position and allowing its easy and quick removal.⁸

6.3 *Irradiance Controller.* The irradiance control system shall maintain the average temperature of the heater thermocouples during calibration at the preset level to within $\pm 2^\circ\text{C}$.

6.3.1 An acceptable system is a “3-term” controller (proportional, integral, and derivative) and a thyristor unit capable of switching currents up to 25 A at 250 V.

6.3.2 The controller shall have a temperature input range of 0°C to 1000°C [32°F to 1832°F], a set scale capable of being read to 2°C [5°F] or better, and automatic cold junction compensation. The controller shall be equipped with a safety feature so that, in the event of an open circuit in the thermocouple line, it causes the temperature to fall to near the bottom of its range.

6.3.3 The thyristor unit shall be of the “zero crossing” type and not of the “phase angle” type.

6.3.4 The heater temperature shall be monitored by a meter capable of being read to $\pm 2^\circ\text{C}$ [5°F] or better.

6.4 *Weighing Device,* for measuring mass loss. The device shall have an accuracy of 0.1 g, and a 90% response time of less than 3 s, as determined in accordance with the calibrations described in 10.2. It should preferably have a specimen measuring range of at least 500 g and a mechanical tare adjustment range of 3.5 kg [7.7 lb].

6.5 *Specimen Holder*

6.5.1 The specimen holder is shown in Fig. 3. It shall have the shape of a square pan with an opening of 106 by 106 mm [4.2 by 4.2 in.] at the top, and a depth of 25 mm [1 in.]. The holder shall be constructed from stainless steel with a thickness of 2.4 ± 0.1 mm [0.094 ± 0.004 in.]. It shall include a handle to facilitate insertion and removal, and a mechanism to ensure central location of the specimen under the heater and proper alignment with the weighing device. The bottom shall be lined with a layer of a low density (nominal density 65 kg/m³ [4 lb/ft³]) refractory fiber blanket with thickness of at least 13 mm [0.5 in.].⁹ The distance between the bottom surface of the cone heater and the top of the specimen shall be adjusted to be 25 mm [1 in.].

6.5.2 An optional retainer frame and grid is useful for testing some samples, and is shown in Fig. 4. The grid is constructed from 1 mm nominal stainless steel and has dimensions of 109 by 109 mm (± 2 mm). The grid has 1 mm ribs and the openings in the

⁷ It is possible that the use of a radiation shield for periods longer than 10 s will affect radiator heat control and, consequently, the heat flux level applied to the specimen.

⁸ This device is necessary in order to enable repeat tests to be carried out without switching off the radiator cone.

⁹ A refractory blanket, RT8 ceramic fiber, Cer-Wool, manufactured by Premier Refractories and Chemicals Inc., King of Prussia, PA, is suitable for this application.

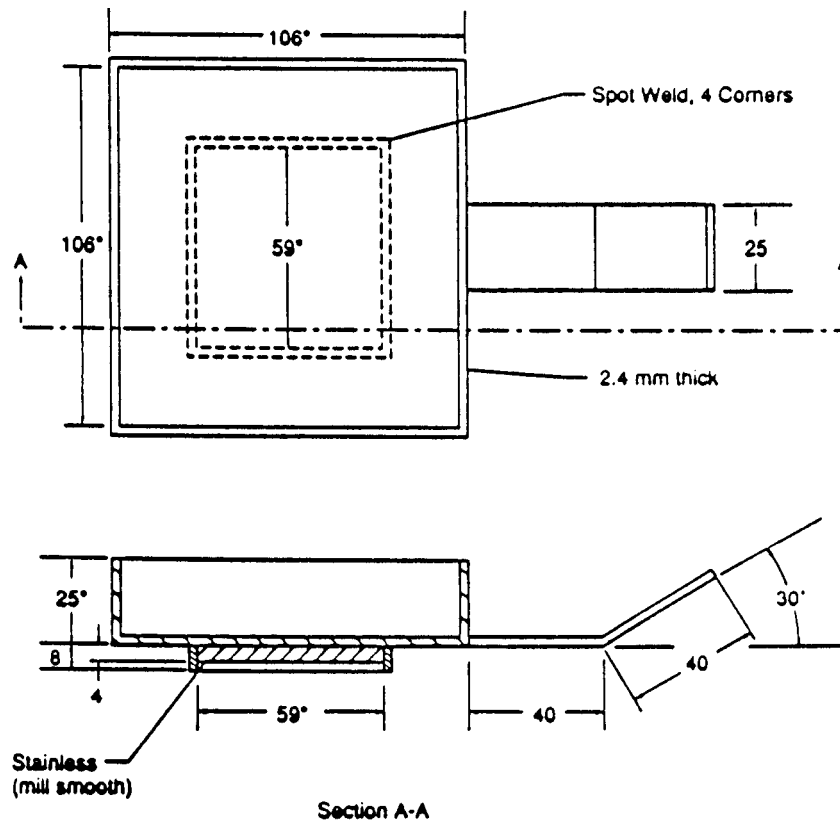

Section A-A
FIG. 3 Horizontal Specimen Holder

center are 19 by 19 mm (± 1 mm). The edge frame is constructed from 2 mm nominal stainless steel with outside dimensions of 116 by 116 by 56 mm height (± 2 mm). The frame has an 8 mm lip on the top to provide an opening of 100 by 100 mm on the top. There are two 3 mm (± 0.5 mm) diameter by 130 mm (± 3 mm) long retaining pins to lock the test specimen in the edge frame.

6.5.3 Details on specimen preparation are given in 9.3.

6.6 *Exhaust Gas System.* Use the instrument under a hood with adequate ventilation to safely remove all combustion products from the laboratory.

6.7 *Ignition Circuit.* External ignition is accomplished by a spark plug powered from a 10-kV transformer or a 10-kV spark generator. The spark plug shall have a gap of 3 mm [0.12 in.]. If used the transformer shall be of a type specifically designed for spark ignition use. The transformer shall have an isolated (unearthed) secondary to minimize interference with the data transmission lines. The electrode length and location of the spark plug shall be such that the spark gap is located 13 mm [0.5 in.] above the center of the specimen, in the horizontal orientation.

6.8 *Ignition Timer.* It shall be capable of recording elapsed time to the nearest 1 s, and shall be accurate to within 1 s in 1 h.

6.9 *Heat Flux Meter*

6.9.1 The heat flux meter shall be of the Schmidt-Boelter (thermopile) type, with a design range of about 100 kW/m². The sensing surface of the heat flux meter shall be flat, circular, of approximately 12.5 mm [0.5 in.] in diameter and coated with a durable matt black finish.¹⁰ The target shall be water-cooled, to the temperature at which it was calibrated, at least at room temperature in the laboratory.¹¹ Radiation shall not pass through any window before reaching the sensing surface. The instrument shall have an accuracy of within $\pm 3\%$ and a repeatability of within $0.5\% - \pm 3\%$.

6.9.2 The calibration of the heat flux meter shall be checked, whenever a recalibration of the apparatus is carried out, by comparison with two instruments of the same type as the working heat flux meter, and of similar range, held as reference standards and not used for any other purpose (see Annex A1). One of the reference standards shall be fully calibrated at a standardizing laboratory, at yearly intervals. This meter shall be used to calibrate the heater. It shall be positioned at a location equivalent to the center of the specimen face, in either orientation, during this calibration.

6.10 *Calibration Burner.* A calibration burner shall be used to calibrate the rate of heat release apparatus (see Fig. 5). The burner shall be constructed from a square-section metallic tube, with a square orifice covered with wire gauze through which methane gas

¹⁰ The target also receives, to a small extent, some convected heat.

¹¹ This test method is under the jurisdiction of ASTM Committee E05 on Fire Standards and is the direct responsibility of Subcommittee E05.21 on Smoke and Combustion Products.

Current edition approved April 1, 2004. Published April 2004. Originally approved in 2000. Last previous edition approved in 2004 as E 2102 - 04.

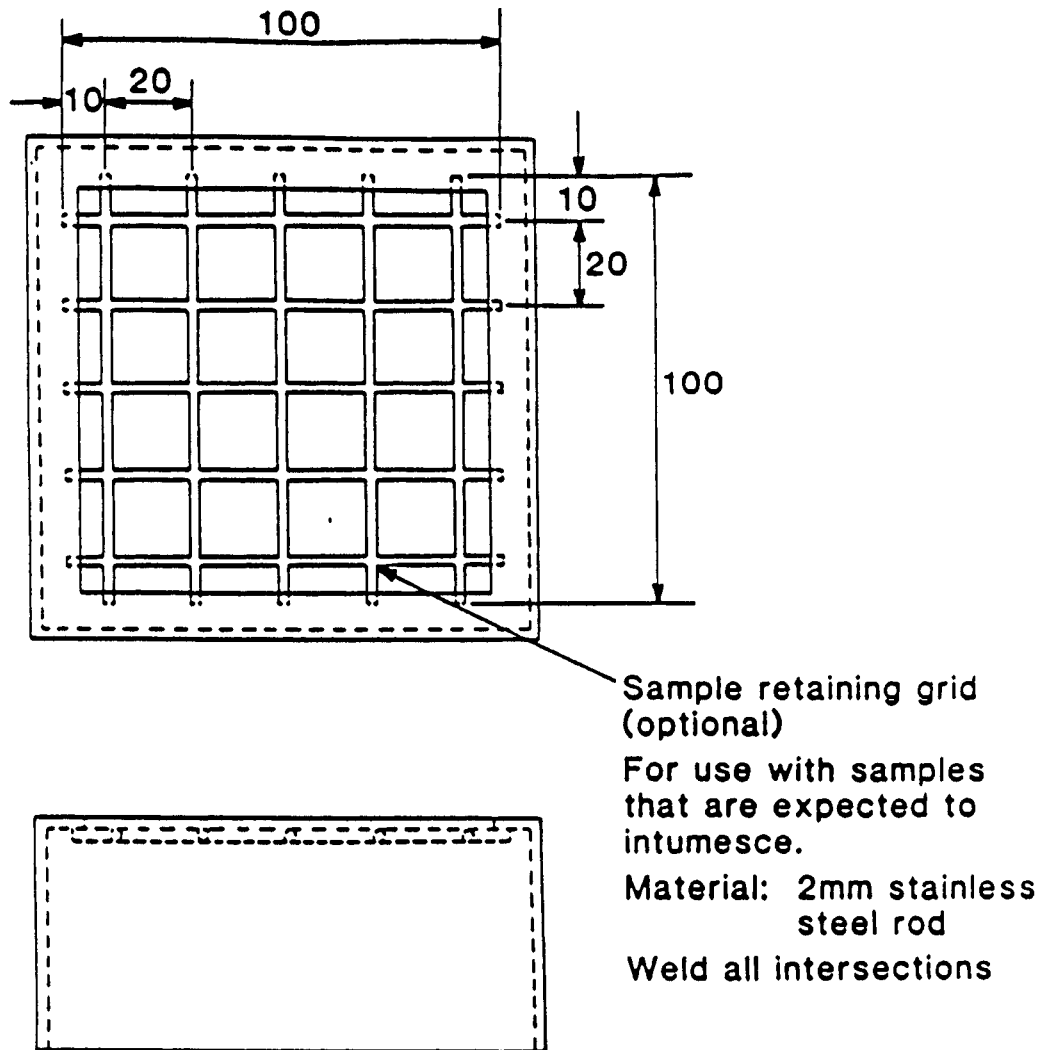

FIG. 4 Optional Wire Grid (For Horizontal or Vertical Orientation)

diffuses. The tube shall be packed with ceramic fiber to improve uniformity of flow. The calibration burner shall be connected to a metered supply of methane, with a purity of at least 99.5 percent.

6.11 *Data Acquisition System.* The data acquisition system shall have facilities to record the output from the load cell and from the thermopile (if used). The data acquisition system shall have an accuracy of 0.01% of full-scale load cell output. The system shall be capable of recording data at least every 5 s for a minimum of 1 h. A chart recorder is an acceptable system, if it meets the accuracy required and the minimum chart speed used is no less than 10 mm/min [0.4 in./min].¹²

7. Operator Safety

7.1 The test procedure involves high temperatures, and combustion processes. Therefore, it is possible for eye injuries, burns, ignition of extraneous objects or clothing, and inhalation of smoke or combustion products to occur, unless proper precautions are taken. To avoid accidental leakage of toxic combustion products into the surrounding atmosphere, it is advisable to fully evacuate the smoke, at the end of a test, into an exhaust system with adequate capacity. The operator must use heavy gloves, safety tongs or other suitable protection for removal of the specimen holder. The venting must be checked periodically for proper operation. Care shall be taken not to touch the spark igniter, which carries a substantial potential (10 kV), during operation. The exhaust system of the apparatus shall be checked for proper operation before testing and shall discharge into a building exhaust system with adequate capacity. The possibility of the violent ejection of molten hot material or sharp fragments from some kinds of specimens when irradiated must be taken into account.

¹² If a chart recorder which only displays a millivolt output is used, the millivolt value shall be converted to heat flux, in kW/m², using the calibration factor (or equation, if appropriate) specific to the heat flux meter.

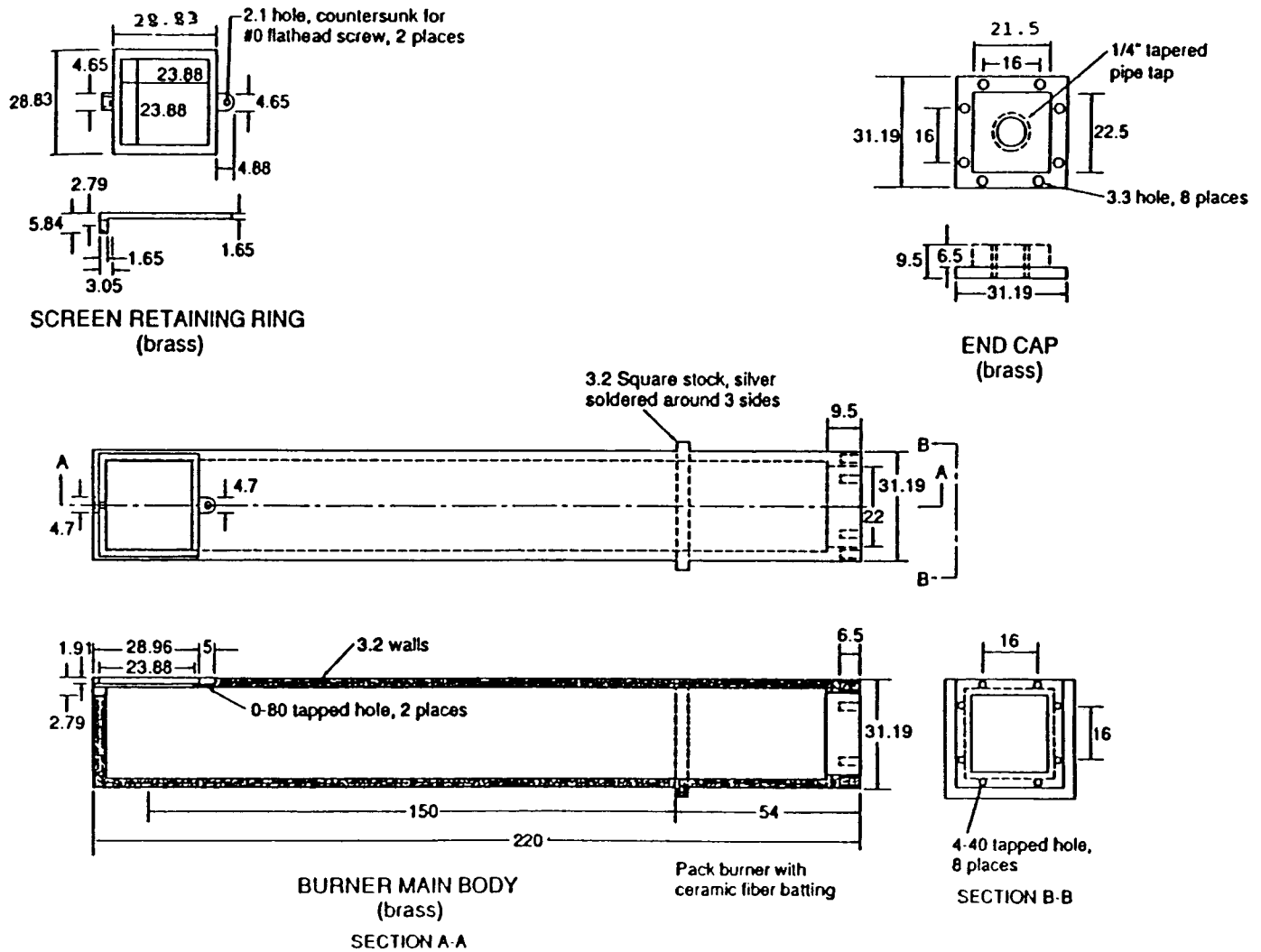

FIG. 5 Calibration Burner

8. Suitability of a Sample for Testing

8.1 *Surface Characteristics.* A product having one of the properties described in 8.1.1 or 8.1.2 is suitable for testing.

8.1.1 An essentially flat exposed surface (see 3.2.4).

8.1.2 A surface irregularity which is evenly distributed over the exposed surface provided that it complies with either 8.1.2.1 or 8.1.2.2.

8.1.2.1 At least 50% of the surface of a representative square area of 100 mm [4 in.] per side lies within a depth of 10 mm [0.4 in.] from a plane taken across the highest points on the exposed surface.

8.1.2.2 The total area of any cracks, fissures or holes does not exceed 30 % of a representative square area 100 mm [4 in.] per side of the exposed surface, and none of the cracks, fissures or holes exceeds 8 mm [0.3 in.] in width nor 10 mm [0.4 in.] in depth.

8.1.2.3 When an exposed surface does not meet the requirements of 8.1.1 or 8.1.2, the product shall be tested in a modified form complying as nearly as possible with the requirements given in 8.1.2. The test report shall then state that the sample has been tested in a modified form and clearly describe the modification.

8.2 *Asymmetrical Products.* A sample submitted for this test is permitted to have faces which differ from each other, or contain laminations of different materials arranged in a different order in relation to the two faces. If either of the faces is potentially exposed to a fire in use within a room, cavity or void, then both faces shall be tested.

8.3 *Thin Materials.* This test method is not suitable, unless modified, for excessively thin samples, since insufficient data will be collected for the calculation of mass loss rates. For some samples, this problem is solved by decreasing the data acquisition interval to 1 s, or increasing the speed of the chart recorder; the test report shall then state that the sample has been tested in a modified form and clearly describe the modification.

8.4 *Composite Specimens.* Composite samples shall be permitted to be tested, provided they are prepared as specified in 9.3.

8.5 *Dimensionally Unstable Materials.* This test method is not suitable, unless modified, for materials that change their dimensions substantially when exposed to the cone radiation. Example of such materials are those that intumesce or those that

shrink away from the cone radiator. In both cases it is likely that the irradiance on the surface of the specimen at the time of ignition will differ significantly from that set initially.

8.5.1 Conduct tests on specimens that intumesce by increasing the separation between the bottom side of the cone heater and the sample surface to 60 mm [2.4 in.], to accommodate the intumescence. Calibration of heat flux at the new separation is required. The test report shall then state that the sample has been tested in a modified form and clearly describe the modification. Specimens that intumesce so much that, when tested at this increased distance, still cause contact either with the spark plug, prior to ignition, or with the underside of the cone heater, are not suitable to be tested by this method.

9. Test Specimen

9.1 Types of Test Specimens

9.1.1 Unless otherwise specified, three specimens shall be tested at each level of irradiance selected and for each different exposed surface.

9.1.2 The specimens shall be representative of the product and shall be square with sides measuring 100 ± 0.5 mm [3.9 ± 0.2 in.].

9.1.3 Samples with normal thicknesses of 50 mm [2 in.] or less shall be tested at their full thickness.

9.1.4 For samples with normal thicknesses of greater than 50 mm [2 in.], the requisite specimens shall be obtained by cutting away the unexposed face to reduce the thickness to 50 ± 0.5 mm [2.0 ± 0.2 in.].

9.1.5 When cutting specimens from samples with irregular surfaces, the highest point on the surface shall be arranged to occur at the center of the specimen.

9.1.6 Assemblies shall be tested as specified in 9.1.3 or 9.1.4, as appropriate. When the product is a material or composite which is normally attached to a well defined substrate in practical use, then it shall be tested in conjunction with that substrate using the recommended fixing technique, for example bonded with the appropriate adhesive or mechanically fixed.¹³

9.1.7 Samples that are thinner than 6 mm [0.25 in.] shall be tested with a substrate representative of end use conditions, such that the total specimen thickness is 6 mm [0.25 in.] or more. In the case of specimens of less than 6 mm [0.25 in.] in thickness and used with an air space adjacent to the unexposed face, the specimens shall be mounted so that there is an air space of at least 12 mm [0.5 in.] between the unexposed face and the refractory fiber blanket.¹⁴

9.1.8 Results obtained from fire test methods are affected by variations in sample geometry, surface orientation, thickness (both overall and of the individual layers), mass, and composition. For any fire test method it is, therefore, important that fire test replicate samples be cut, sawed, or blanked to identical sample areas, and that records be kept of the respective masses with the individual test data. Evaluation of the data obtained, together with the individual masses, will assist in assessing the reasons for any observed variability in measurements.

9.2 Conditioning

9.2.1 Before the test, condition the specimens to constant mass at a temperature of 23 ± 2 °C [73 ± 5 °F], and a relative humidity of 50 ± 5 %.

9.2.2 Constant mass is considered to have been reached when two successive weighing operations, carried out at an interval of 24 h, do not differ by more than 0.1% of the mass of the test piece or 0.1 g, whichever is the greater.

9.3 Specimen Preparation

9.3.1 *Specimen Wrapping.* A conditioned specimen shall be wrapped in a single layer of aluminum foil, of 0.03 to 0.05 mm [0.001 to 0.002 in.] thickness, with the shiny side towards the specimen, covering the unexposed surfaces. Composite specimens shall be exposed in a manner typical of the end use condition (for example, if used with an air gap (see 9.1.6), an air gap shall be included behind the specimen, within the aluminum foil).

9.3.2 *Specimen Preparation.* All test specimens shall be tested with the retainer frame shown in Fig. 4. The steps outlined in 9.3.2.1-9.3.2.5 shall be taken to prepare the specimen for testing.

NOTE 2—Use of the retainer frame is an option in Test method E 1354.

9.3.2.1 Put the retainer frame on a flat surface facing downwards.

9.3.2.2 Insert a foil-wrapped specimen into the retainer frame, with the exposed surface facing downwards.

9.3.2.3 Put layers of ceramic fiber blanket (nominal thickness 13 mm [0.5 in.], see section 6.5) on top of the sample, until 2 layers extend above the rim of the retainer frame.

9.3.2.4 Fit the sample holder into the retainer frame, on top of the ceramic fiber and press downwards.

9.3.2.5 Tighten the screw at the bottom of the retainer frame and turn the frame around.

10. Calibration

10.1 *Heater Calibration.* Remove the radiation shield before a heater calibration. Adjust the temperature controller so that the conical heater produces the required irradiance, as measured by the heat flux meter, (a) at the start of each test day, (b) when

¹³ Where thin materials or composites are used in the fabrication of an assembly, it is likely that the presence of air or an air gap or the nature of any underlying construction will significantly affect the ignition and burning characteristics of the exposed surface. Take steps to ensure that the test result obtained on any assembly is relevant to its use in practice.

¹⁴ A suitable means of achieving this is by the use of a metal spacer frame.

changing to a new irradiance or (c) when the conical heater orientation is changed. Do not use a specimen or a specimen holder when the heat flux meter is inserted into the calibration position. Operate the cone heater for at least 10 min and ensure that the controller is within its proportional band before beginning this calibration.

10.2 *Mass Measuring System Calibration*. Calibrate the load cell with standard weight pieces in the range of test specimen mass at least every day, and whenever the load cell zero needs to be adjusted.¹⁵

11. Test Procedure

11.1 Initial Preparation

11.1.1 Turn on power to the cone heater and the exhaust fan. Do not turn off power to the load cell on a daily basis.

11.1.2 Perform the required calibration procedures specified (10.1 and 10.2). Put a thermal screen on top of the load cell (an empty specimen holder with a refractory blanket is suitable) during warm-up and between tests, to avoid excessive heat transmission to the load cell.

11.1.3 Unless external ignition is not to be used, position the spark plug holder in the location appropriate to the orientation being used (6.7).

11.2 Procedure

11.2.1 When ready to test, first remove the empty specimen holder (see 11.1.3).

11.2.2 Move the radiation shield in position, and place the specimen holder, with the test specimen, under the heater. The specimen holder shall be at room temperature initially.

11.2.3 Remove the radiation shield within 10 s. Immediately, move the spark igniter into place, and turn on the power to the spark igniter and start data collection simultaneously. If a computerized data acquisition system is used (see 6.11), data collection intervals shall be 5 s or less.

11.2.4 Record the times when flashing or transitory flaming occur; when sustained flaming occurs, record the time, turn off the spark, and remove the spark igniter. If the flames extinguish after turning off the spark, reinsert the spark igniter and turn on the spark, within 5 s of extinguishment. The spark igniter shall then be left in position until sustained flaming resumes or until the 15 minute sustained flaming period has elapsed. Report all these events in the test report.

11.2.5 Collect all data until 32 min after the time to sustained flaming, 2 min after any flaming or other signs of combustion cease or the average mass loss per unit area over a 1 min period has dropped below 150 g/m², whichever occurs first.

11.2.6 If the specimen does not ignite in 30 min, remove and discard, unless the specimen is showing signs of heat evolution.

NOTE 3—Test method E 1354 specifies a 10 min test period if the specimen does not ignite.

11.2.7 Remove specimen and specimen holder.

11.2.8 Replace an empty specimen holder. Let the chimney (if used) cool between tests.

11.2.9 Test three specimens and report the results as described below. Compare the 180 s mean mass loss rate readings for the three specimens. If any of these mean readings differ by more than 10 % from the arithmetic mean of the three readings, then test a further set of three specimens. In such cases, report the arithmetic mean of the set of six readings.

11.3 Record any particular burning characteristics of the specimens, such as delamination, intumescence, shrinkage, melting, dripping, collapse, occurrence of pool fire under the test specimen, or any other event of special interest, and record the time at which the particular behavior occurs, including the time to ignition and duration of flaming. Also record the smoke characteristics, such as color, and the nature of the settled particulate matter. Report all times from the moment the test was started.

12. Test Report

12.1 The test report shall be as comprehensive as possible and shall include any observations made during the test and comments on any difficulties experienced during testing. The units for all measurements shall be clearly stated in the report.

12.2 Include the following descriptive information in the test report:

12.2.1 Name and address of the testing laboratory.

12.2.2 Date and identification number of the report.

12.2.3 Name and address of the test requester, when applicable.

12.2.4 Name of manufacturer or supplier of material, product, or assembly tested, if known.

12.2.5 Commercial name or other identification marks and description of the sample.

12.2.6 Full description of the sample, including such aspects as type, form, essential dimension, mass (in g) or density, color and coverage rate of any coating.

12.2.7 Full description of specimen construction and preparation (see 9.1 and 9.3).

12.2.8 Face of specimen tested (see 8.2).

12.2.9 Thickness of each specimen tested, in mm.

12.2.10 With composites or assemblies, the nominal thickness and density of each of the components, together with the apparent (overall) density of the specimen.

¹⁵ It is possible that the load cell zero will need adjustments after changing orientation, due to different specimen holder tare masses.

- 12.2.11 Conditioning of the test specimens.
- 12.2.12 Date of the test.
- 12.2.13 Test orientation and specimen mounting details.
- 12.2.14 Irradiance, in kW/m².
- 12.2.15 Number of replicate specimens tested (minimum of three).
- 12.2.16 Test number and any special remarks.
- 12.3 Include the following test results in the test report.
 - 12.3.1 Table of numerical results containing the following information for each specimen tested.
 - 12.3.1.1 Time to sustained flaming, in s.
 - 12.3.1.2 Test duration: the time elapsed between the start of the test and the end point (11.2.5 or 11.2.6), in s.
 - 12.3.1.3 Total mass lost during the test, in g and in % of initial mass.
 - 12.3.1.4 Sample mass loss per unit area, in kg/m².
 - 12.3.1.5 Average rate of specimen mass loss per unit area, in g/(s m²), computed over the period between ignition and the end of the test.
 - 12.3.1.6 Maximum rate of specimen mass loss per unit area, in g/(s m²), computed over the period between ignition and the end of the test.
 - 12.3.1.7 Time to maximum value of mass loss rate per unit area, in s.
 - 12.3.1.8 Average values of all magnitudes determined in 12.3.1.1-12.3.1.7.
 - 12.3.2 Graphical results, for each specimen tested.
 - 12.3.2.1 Graph of mass loss rate per unit area against time.
 - 12.3.2.2 Graph of heat release rate per unit area against time (if optional heat release has been measured).
 - 12.3.3 *Descriptive Results*
 - 12.3.3.1 All available information required in sections 8 and 9.1 (regarding specimen selection), 9.3 (regarding specimen preparation) and in sections 11.2 and 11.3 (observations regarding burning characteristics of the specimens and any events of special interest during the tests).
 - 12.3.3.2 Details of any invalid tests, with reasons for them being invalid (see 5.7.2 and 11.2.9).

13. Precision and Bias

13.1 *Precision*—The precision of this test method has not been fully determined. The results of a planned interlaboratory test series will be included when available. Tables X2.1 and X2.2 contain some data on precision, based on tests conducted in one laboratory. Within that very limited study, the relative standard deviation of the properties was found to be generally within $\pm 10\%$. This level of precision may not be valid for other materials.

13.2 *Bias*—No information is presented on the bias of the procedure in this test method because correct values of fire-test-response characteristics of materials, products or assemblies tested in accordance with this method can only be defined in terms of a test method. Within this limitation, this test method has no known bias.

14. Keywords

- 14.1 cone heater; fire; fire-test-response characteristic; heat release; ignitability; mass loss

ANNEXES

(Mandatory Information)

A1. CALIBRATION OF THE WORKING HEAT FLUX METER

A1.1 The calibration of the heat flux meter shall be checked, whenever a recalibration of the apparatus is carried out, by comparison with two instruments of the same type as the working heat flux meter and of similar range, held as reference standards and not used for any other purpose. One of the heat flux meter reference standards shall be fully calibrated at an accredited laboratory at yearly intervals. This meter shall be used to calibrate the heater temperature controller. It shall be positioned at a location equivalent to the center of the specimen face during this calibration. One option for making the intercomparison of working and reference standard heat flux meters required, is the use of the conical heater, with each heat flux meter mounted in turn in the calibration position, care being taken to allow the whole apparatus to attain thermal equilibrium. Alternatively, use an apparatus specially built for comparative purposes, for example as described in BS 6809, or in Test Method E 638.¹⁶

¹⁶ The use of two reference standards rather than one provides a greater safeguard against change in sensitivity of the reference instruments.

A2. OPTIONAL COLUMN WITH THERMOPILE

A2.1 *Thermopile and Housing.* This equipment is not mandatory. If required for temperature measurements, a chimney, with a circular cross-section, 300 mm [12 in.] long and 115 mm [5 in.] inner diameter, constructed from 1 mm [0.04 in.] thick stainless steel shall be used to house a thermopile. This is fixed to the top of the top plate of the conical heater. The thermopile consists of four 1.6 mm [0.06 in.] outside diameter sheathed thermocouples (of the ungrounded junction type). The thermocouples are housed within the chimney, at a height of 150 mm [6 in.] above the top plate of the cone heater, and the chimney penetration points are equally distributed around the circumference of the chimney. The tips of the thermocouples are fixed 17 mm [0.67 in.] from the centerline of the chimney, by weaving them into the mesh of a 70 mm [2.8 in.] diameter circular sheet of 10 mesh steel gauze (Fig. A2.1).

A2.2 The thermopile captures only a fraction of the heat, principally that which goes into warming the smoke (combustion products). Another fraction of the heat will be lost to the surroundings by radiation. Convective effects heat both the chimney itself and the thermopile. Thus, due to the radiative losses, the heat release rate measured by this thermopile method will be lower than that measured by oxygen consumption calorimetry.

A2.3 Calibration of the thermopile output using a 3 kW methane flame, accounts for the thermopile column heating effects to some extent. The output of the thermopile is scaled to correspond to a heat release rate of 3 kW. This accounts for the radiation heat loss from the methane flame and the effects of heat loss to the chimney walls. However, this scaling is not as accurate for determining the heat release from a sample unless the radiant fraction of the heat release and the optical characteristics of the combustion products are identical to those of the methane calibration flame. If the radiant fraction of the heat release from the sample is higher than that of the methane calibration flame, the indicated heat release will be lower than the actual heat release. If the combustion products contain more soot than those of the calibration flame, the emissivity of the combustion products will increase. As the emissivity of the combustion products increases, the time constant of the thermopile decreases and the colder chimney walls do not affect the thermopile reading as much. The net effect will be an increase in the indicated heat release rate.

A2.4 *Thermopile Calibration.* The thermopile shall initially be calibrated at each test irradiance using the procedure given in A2.5.1. Thereafter it shall be checked at the operating irradiance before starting work each day.

A2.4.1 *Initial Calibration.* The calibration burner described in 6.10 and a data acquisition system, or a chart recorder are required for this task. The calibration shall be undertaken at each irradiance level used for testing. Set the radiators at the set irradiance and allow the system to stabilize. Place the calibration burner in position and introduce methane at a flow rate corresponding to 5 kW, based on the net heat of combustion of methane (50.0×10^3 kJ/kg), using a pre-calibrated flow meter. Suitable flow meters include used rotameters, dry test meters, wet test meters, or electronic mass flow controllers. Record the stabilized output from the thermopile. Repeat the above procedure for methane flow rates equivalent to 4, 3, 2, 1, 0.75, 0.5 and 0.25 kW. Construct a calibration graph of thermopile output versus heat input.

A2.4.2 *Daily Calibration.* At the beginning of each working day, or when the operating irradiance is changed, check the thermopile output with a flow rate of methane corresponding to 3 kW. If this lies within $\pm 5\%$ of that shown in the initial calibration, proceed with testing. If it does not lie in that range, check the thermopile for correct positioning. If the thermopile is correctly positioned and this is not the source of the error, then recalibrate the system in accordance with 10.1.

A2.5 Fig. A2.2 shows an experimental representation of a plot of heat release rate (in kW/m²) as a function of temperature (in K), corresponding to Eq A2.1:

$$\text{Heat Release Rate [kW/m}^2\text{]} = 1.46 * \text{Temperature [K]} - 395 \quad (\text{A2.1})$$

A2.5.1 It is possible that Eq A2.1 will be affected by variations in apparatus design.

A2.6 If the thermopile is used, the test report shall include the following:

A2.6.1 Values of heat release rate per unit area at 180 s after ignition, in kW/m².

A2.6.2 Value of heat release rate per unit area at 300 s after ignition, in kW/m².

A2.6.3 Maximum value of heat release rate per unit area, in kW/m².

A2.6.4 Time to maximum value of heat release rate per unit area, in s.

A2.6.5 Total heat released per unit area over the entire test, in MJ/m².

A2.6.6 Average values of all magnitudes determined in A2.6.1-A2.6.5.

PLAN
Showing thermocouple locations on circular mesh housing

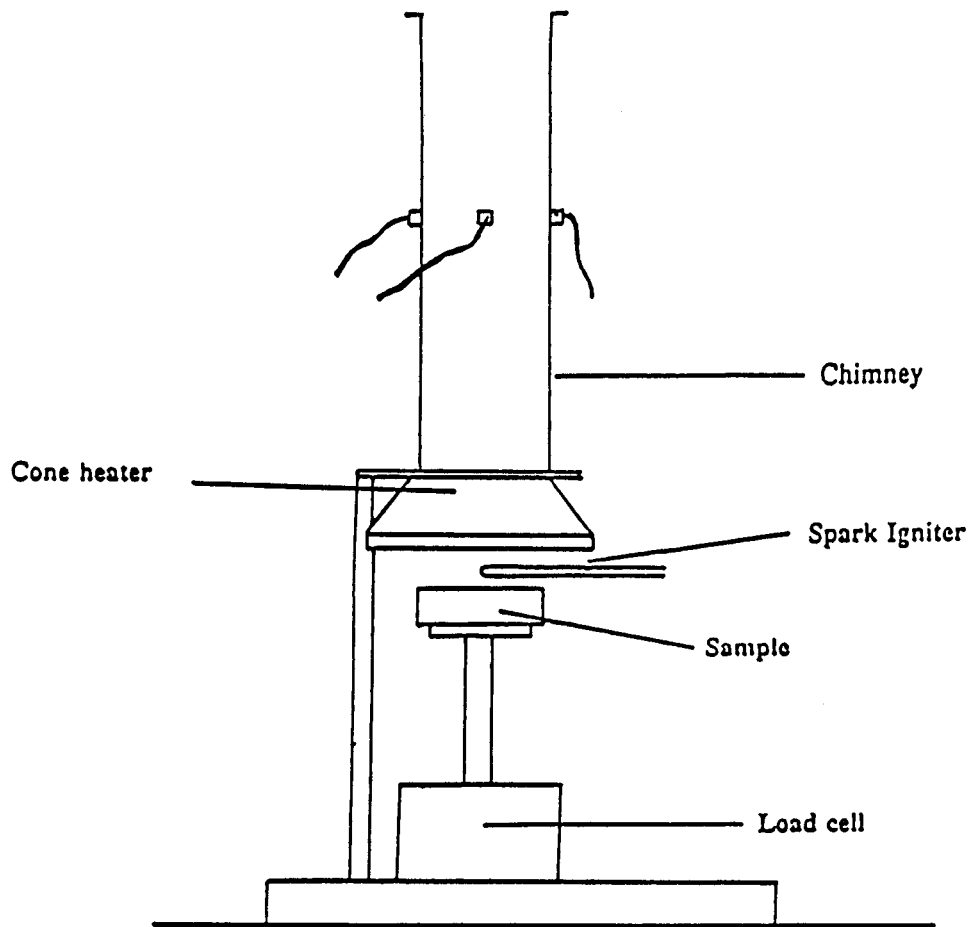
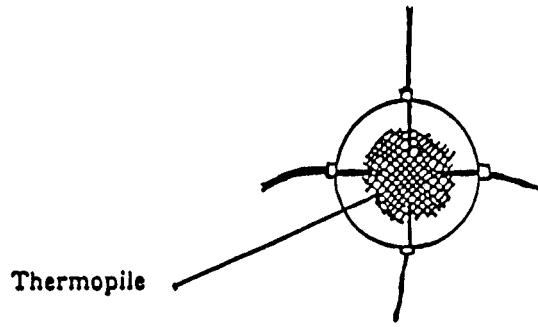

FIG. A2.1 Schematic of Apparatus (Including Thermopile)

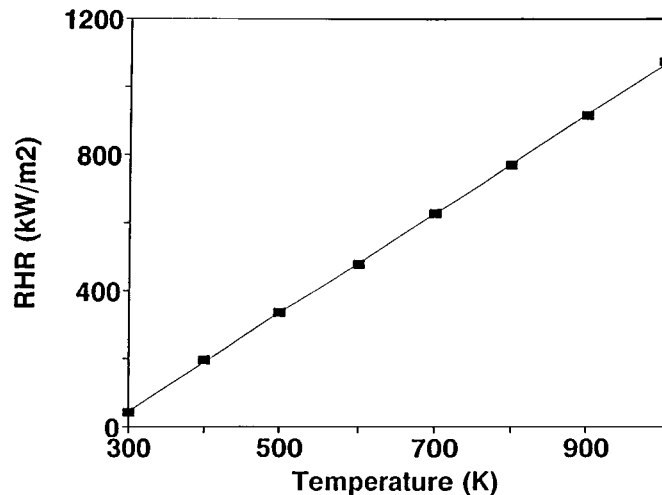

FIG. A2.2 Rate of Heat Release (in kW/m²) as a Function of Thermocouple Temperature (in K)

APPENDIXES

(Nonmandatory Information)

X1. COMMENTARY AND GUIDANCE NOTES FOR OPERATORS

X1.1 Introduction

X1.1.1 This appendix aims to provide the test operator, and perhaps the user of the test results, with background information on the method, the apparatus and the data obtained.

X1.2 Rate of Heat Release

X1.2.1 Rate of heat release is one of the most important variables, possibly even the single most important variable, in determining the hazard from a fire (1-5).¹⁷ In particular, the rate of heat release is a measure of the intensity of the fire (2, 5). The rate of heat release and the amount of heat released in actual fires will determine the extent to which other materials, products or assemblies in the fire compartment may ignite and spread the fire further. The amount of smoke generated is often a direct function of the heat release rate, particularly in large scale tests (6-8).

X1.2.2 The rate of heat release can be determined by measuring the oxygen depletion in a fire atmosphere (9-11). Oxygen concentration measurement devices, of the paramagnetic type, are now sufficiently precise to measure the small differences in oxygen concentration needed for determining rate of heat release. This technique is used in Test Methods D 5537, D 6113, E 1354, E 1474, E 1537, E 1590, E 1623, E 1740 and E 1822. Internationally it is used also in ISO 5660, ISO 9705 and in BS 476 Part 15.

X1.2.3 However, heat release apparatuses using the oxygen consumption principle are relatively costly, and approximate results, for screening test purposes, can be obtained using the thermopile technique, which is available in North America (Test Method E 906), and internationally ISO/CD 13927 (12).

X1.3 Rate of Heat Release Measurements

X1.3.1 The test method does not prescribe the irradiance levels, specimen orientation, or whether external ignition is to be used. These must be determined separately for each sample to be assessed. For given applications and products, a comparison with some full scale fires is often necessary to determine the time period over which heat release is to be calculated.

X1.3.2 For exploratory testing, it is recommended to use the spark igniter and an irradiance value of 35 kW/m² initially; in the absence of further specifications from the sponsor, tests at three irradiances, such as 25, 35 and 50 kW/m² are recommended. Results obtained are then likely to suggest whether additional testing at different irradiance levels is desirable.

X1.3.2.1 The heating fluxes to be chosen for this test method should be relevant to the material, product, or assembly being investigated and its intended applications.

X1.3.3 It is likely that the test results are not statistically significant unless the irradiance used is substantially (10 kW/m²) higher than the minimum irradiance level needed for sustained flaming to occur for that specimen.

¹⁷ The boldface numbers in parentheses refer to the list of references at the end of this test method.

X1.3.4 It has been found that for many materials the test results at different irradiances are probably not statistically significantly different unless the irradiances used are substantially (10 kW/m^2 or more) different from each other.

X1.3.5 A significant change in the amount of visible smoke as a result of a small change in formulation is an indicator of a large change in the radiative fraction of the heat released, which can cause errors in rate of heat release measurements with a thermopile.

X1.4 Heater Design

X1.4.1 Experience with various reaction-to-fire measurement techniques suggests that, for minimal errors in irradiance, the specimen should see only either a thermostatically controlled heater, or a water cooled plate or open air. Nearby solid surfaces, if they are not temperature controlled, can rise in temperature due to specimen flame heating and then act as further sources of radiation back to the specimen which can lead to errors.

X1.4.2 The heater, in the shape of a truncated cone, initially developed for ISO 5657 has been modified to include higher irradiances, temperature control, flow streamline improvement and to be of a more rugged design. The conical shape approximately follows the fire plume contours while the central hole allows the stream to emerge without impacting on the heater. Air entrainment ensures the flames do not reach the sides of the cone.

X1.5 Piloted Ignition

X1.5.1 Ignition of test specimens in many apparatuses is achieved by a gas pilot. This however can present difficulties when assessing heat release due to its contribution to heat output, deterioration of orifices and sooting. Its design is also difficult since it must be centrally located, be resistant to extinguishment by draughts and fire retardants, and, most importantly, not apply additional heat to the specimen. An electric spark is free of most of these difficulties and has therefore been adopted as the igniter. The spark igniter requires only occasional cleaning and adjustment of the electrodes.

X1.6 Back Face Conditions

X1.6.1 The heat losses through the back face of the specimen can have an influence on the burning rate near the end of its burning time. For reproducible measurements the loss through the back face should be standardized and this is achieved by using a layer of insulating material.

X1.7 The temperature measured by the thermocouple shown in Fig. 2 is not intended to represent a precise measurement of the effective radiation temperature, since the temperature reading is used only to maintain the heat flux on the test specimen at its pre-calibrated value.

X2. MASS LOSS MEASUREMENTS

X2.1 Mass loss measurements using the apparatus for this test method have been shown to be useful for understanding the mechanism of polymer breakdown (see, for example, Fig. X2.1 (13)) and the effects of fire retardants (see, for example Fig. X2.2 (14)).

X2.2 Thermogravimetric analysis, which has also been used to assess polymer breakdown mechanisms, involves very small samples (often under 1 g) and energy exposure conditions which are totally different from the ones used in fire testing, and can rarely be used as a screening test for fire properties.

X2.3 Equipment suitable for this test method has been used, enclosed in a flow-through chamber at controlled air flow rates, to measure ignitability and mass loss rate of various materials (15-17).

X2.4 For materials or products containing sorbed water or molecularly-bound water, the mass loss observed will be a somewhat inaccurate representation of the combustion process as the water mass loss will overstate the process.

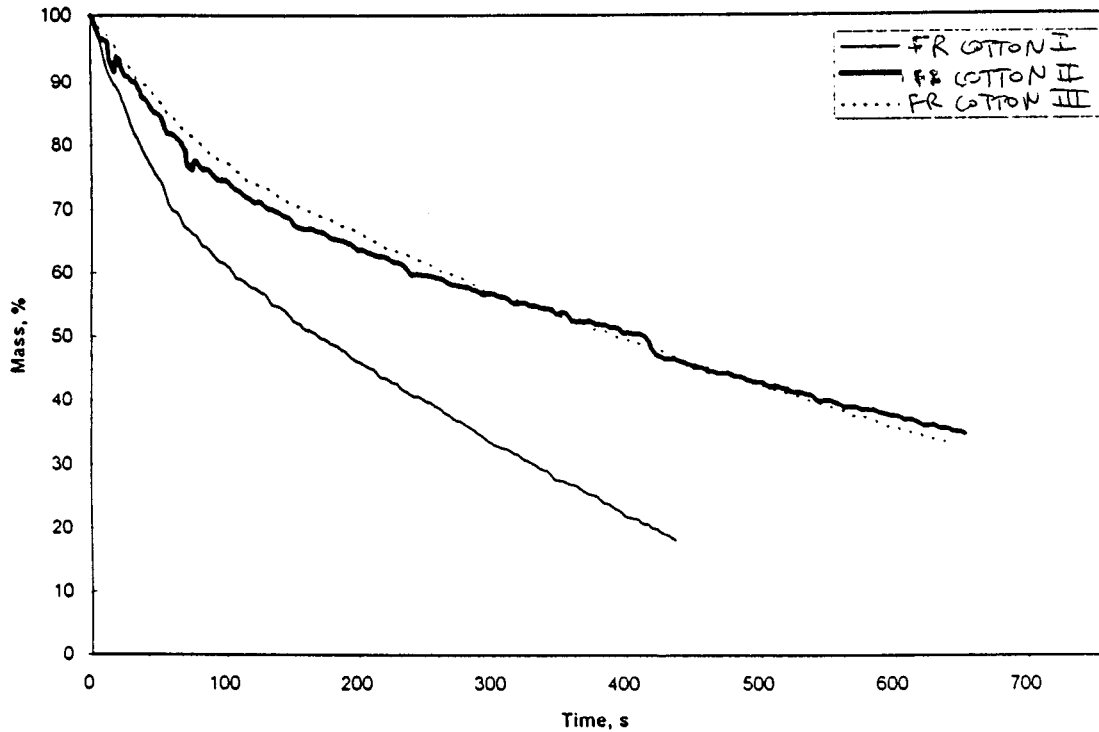

FIG. X2.1 Mass Loss Calometric Curves for Three Fire Retardant-Treated Cotton Samples at an Incident Heat Flux of 50 kW/m²

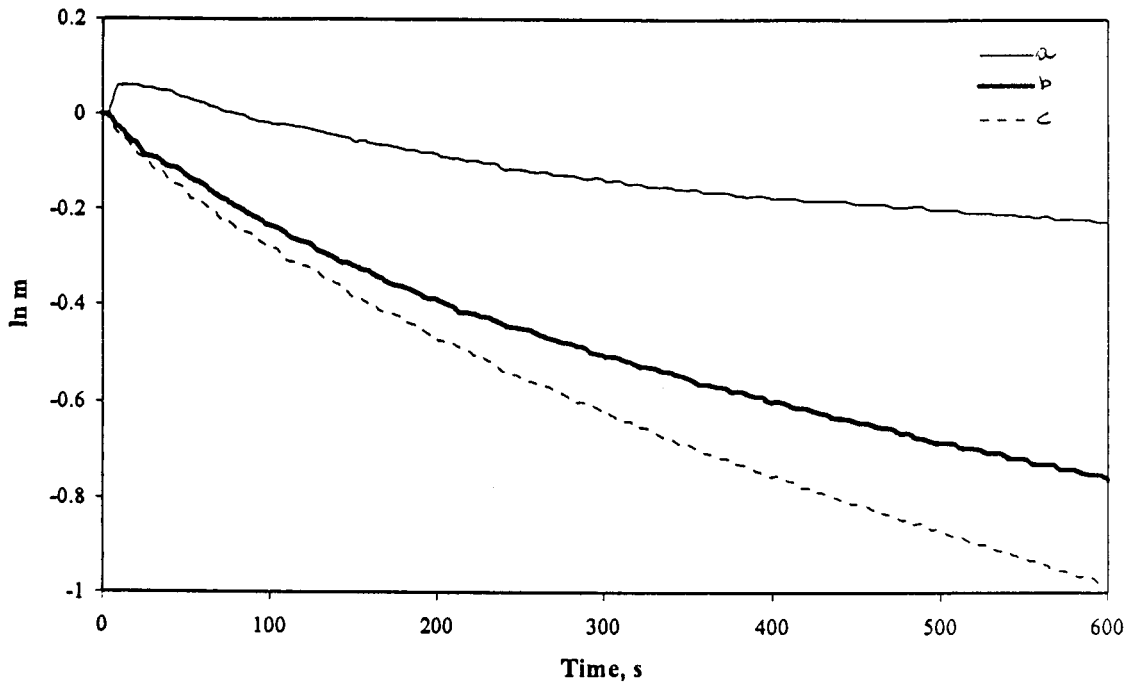

FIG. X2.2 Logarithm of Mass Loss Calometric Curves for a Fabric/Fire Retardant System, at Three Different Incident Heat Fluxes: (a) 25 kW/m², (b) 50 kW/m² and (c) 75 kW/m²

X3. CRITICAL FLUX FOR IGNITION

X3.1 The theoretical critical flux for ignition is the minimum heating flux to cause ignition of the sample. It is normally determined as the intercept of a plot of the square root of the inverse of the time to ignition as a function of heating flux.

X3.2 In order to determine the critical flux for ignition with sufficient accuracy it is essential to have fire test data at a minimum

of three heating fluxes. The precision of the results is likely to increase if the number of tests increases, particularly if the data has been generated at several different heating fluxes.

X3.3 If no ignition is observed at a certain heating flux, the use of a higher heating flux is likely to generate data more appropriate for obtaining ignition and mass loss rate information than that obtained when ignition did not occur. Such data could be used for screening purposes before conducting fire hazard assessment calculations.

X4. CORRELATION WITH CONE CALORIMETER RESULTS

X4.1 Fig. X4.1(13) and Fig. X4.2 (14) show the results of testing a specimen of poly(methyl methacrylate) (PMMA), 50 mm thick, using the cone calorimeter and using the mass loss calorimeter screening test method described, at incident heat fluxes of 35 and 50 kW/m². The results indicate that adequate screening is obtained.

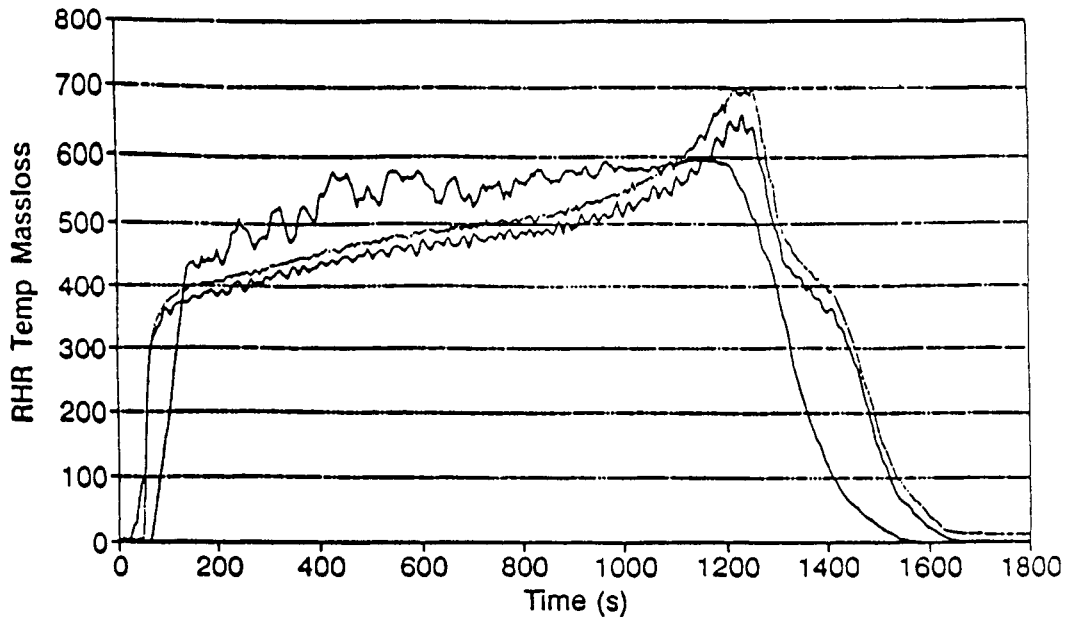

FIG. X4.1 Mass Loss Calorimeter and Cone Calorimeter Curves Resulting from Testing PMMA at an Incident Heat Flux of 35 kW/m²: (a) Mass Loss with the Mass Loss Calorimeter, (b) Heat Release via the Optional Temperature Measurements with the Mass Loss Calorimeter, and (c) Heat Release via Oxygen Consumption Measurements with the Cone Calorimeter

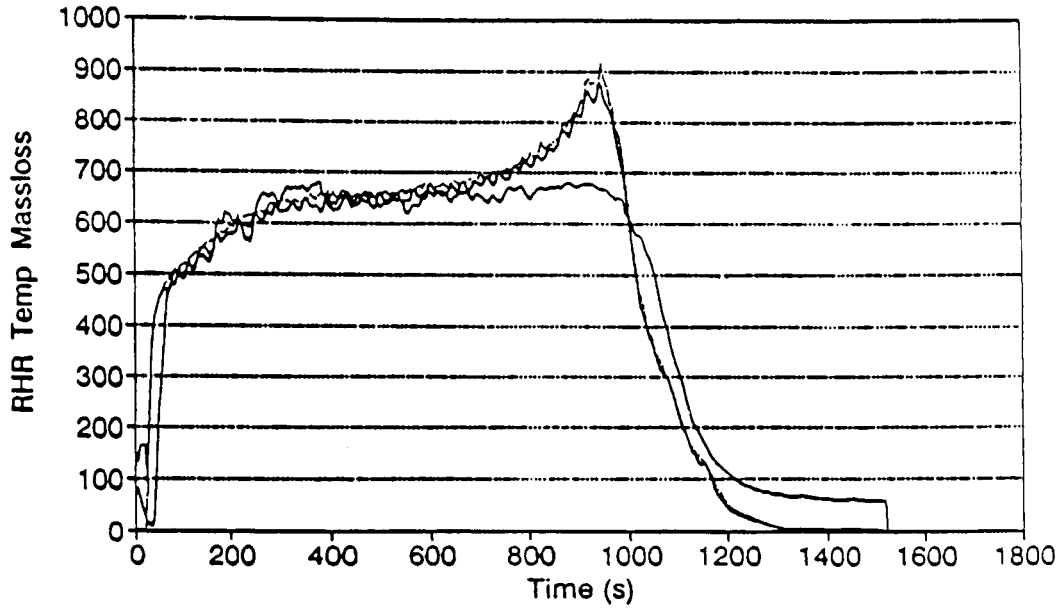

FIG. X4.2 Mass Loss Calorimeter and Cone Calorimeter Curves Resulting from Testing PMMA at an Incident Heat Flux of 50 kW/m²:
 (a) Mass Loss with the Mass Loss Calorimeter, (b) Heat Release via the Optional Temperature Measurements with the Mass Loss Calorimeter, and (c) Heat Release via Oxygen Consumption Measurements with the Cone Calorimeter

X5. PRECISION

X5.1 Table X5.1 presents data on precision, based on tests conducted in one laboratory, in triplicate, on three homogeneous plastic materials at an incident heat flux of 70 kW/m². Table X5.2 presents data on precision, based on tests conducted in the same laboratory, in triplicate, on two granular materials, tested at incident heat fluxes of 20 and 40 kW/m² (18).

TABLE X5.1 Repeatability of Data on Some Homogeneous Plastics in One Laboratory^A

		Time to Ignition s	Test Duration s	Av MLR g/(s m ²)	Pk MLR g/(s m ²)	Mass Loss %	Time to Pk MLR s
Plastic 1	1	14.0	820	0.77	1.62	53.4	340
	2	14.0	850	0.74	1.63	52.9	320
	3	15.0	895	0.73	1.52	53.2	325
	Avg	14.3	855	0.75	1.59	53.2	328
	STD	0.6	37.7	0.02	0.06	0.3	10.4
	RSD	4.0	4.4	2.8	3.8	0.5	3.2
Plastic 2	1	18.0	900	0.80	1.44	55.7	290
	2	18.0	845	0.74	1.43	54.1	310
	3	18.0	850	0.81	1.46	57.1	320
	Avg	18.0	865	0.78	1.44	55.6	307
	STD	0.0	30.4	0.04	0.02	1.5	15.3
	RSD	0.0	3.5	4.8	1.1	2.7	5.0
Plastic 3	1	14.0	820	0.77	1.45	54.3	320
	2	15.0	810	0.78	1.45	52.8	310
	3	16.0	815	0.79	1.63	53.7	360
	Avg	15.0	815	0.78	1.51	53.6	330
	STD	1.0	5.0	0.01	0.10	0.8	26.5
	RSD	6.7	0.6	1.3	6.9	1.4	8.0

^AExplanation of abbreviations:
 Av MLR-average mass loss rate,
 Pk MLR-peak mass loss rate,
 Avg-average of replicate test results,
 STD-standard deviation of replicate test results, and
 RSD-relative standard deviation, namely 100 times the ratio of Avg and STD.

TABLE X5.2 Repeatability of Data on Some Granular Materials in One Laboratory^A

		Time to Ignition s	Test Duration s	Av MLR g/(s m ²)	Pk MLR g/(s m ²)	Mass Loss %	Time to Pk MLR s
Granule 1 @ 20	1	66	790	0.10	0.21	99.3	638
	2	73	758	0.10	0.22	100	576
	3	76	798	0.12	0.25	99.6	660
	Avg	71.7	782	0.10	0.23	99.6	625
	STD	5.1	21.2	0.01	0.02	0.4	43.6
	RSD	7.2	2.7	9.5	9.9	0.4	7.0
Granule 1 @ 40	1	20	374	0.19	0.45	99.7	330
	2	20	436	0.18	0.39	100	396
	3	20	436	0.18	0.42	100	388
	Avg	20.0	415	0.18	0.42	99.9	371
	STD	0.0	35.8	0.01	0.03	0.2	36.0
	RSD	0.0	8.6	3.0	6.8	0.2	9.7
Granule 2 @ 20	1	181	1192	0.11	0.19	100	1028
	2	213	1070	0.12	0.25	99.7	922
	3	217	982	0.12	0.23	99.7	982
	Avg	203.7	1107	0.12	0.23	99.8	977
	STD	19.7	74.1	0.01	0.03	0.3	43.4
	RSD	9.7	6.7	6.1	12.6	0.3	4.4
Granule 2 @ 40	1	40	582	0.19	0.55	99.4	488
	2	44	590	0.20	0.42	85.0	590
	3	45	576	0.19	0.48	100	536
	Avg	43.0	583	0.19	0.48	94.8	538
	STD	2.6	7.0	0.005	0.06	8.5	41.7
	RSD	6.2	1.2	2.7	13.4	9.0	7.7

^AExplanation of abbreviations:
 Av MLR-average mass loss rate,
 Pk MLR-peak mass loss rate,
 Avg-average of replicate test results,
 STD-standard deviation of replicate test results, and
 RSD-relative standard deviation, namely 100 times the ratio of Avg and STD.

REFERENCES

- (1) Babrauskas, V., Lawson, J., Walton, W., and Twilley, W., "Upholstered Furniture Heat Release Rates Measured with the Furniture Calorimeter," NBSIR 82-2604, 1083.
- (2) Thomas, P.H., in "Int. Conf. FIRE: Control the Heat...Reduce the Hazard," 24-25 October 1988, London, UK, QMC Fire & Materials Centre, paper 1.
- (3) Babrauskas, V., in "Int. Conf. FIRE: Control the Heat...Reduce the Hazard," 24-25 October 1988, London, UK, QMC Fire & Materials Centre, paper 4.
- (4) Hirschler, M.M., "How to measure smoke obscuration in a manner relevant to fire hazard assessment: Use of heat release calorimetry test equipment," J. Fire Sciences, 9, 183-222 (1991).
- (5) Babrauskas, V. and Peacock, R.D., "Heat Release Rate. The Single Most Important Variable in Fire Hazard," Fire Safety Journal, 18 255-72 (1992).
- (6) Ostman, B.A.L. and R.M. Nussbaum, "Correlation Between Small Scale Rate of Heat Release and Full Scale Room Flashover for Surface Linings," in *Fire Safety Science, Proc. 2nd. Int. Symp.*, Tokyo, Japan, 13-17 June, 1988, Wakamatsu, T., Hasemi, Y., Sekizawa, A., Seeger, P.G., Pagni, P.J. and Grant, C.E., Eds, Hemisphere, Washington, DC, 1989, pp. 823-32.
- (7) Hirschler, M.M., "Heat release from plastics," Chapter 12 a, in "Heat Release in Fires," Elsevier, London, UK, Eds. V. Babrauskas and S.J. Grayson, 1992. pp. 375-422.
- (8) Hirschler, M.M., "Survey of fire testing of electrical cables," M.M. Hirschler, Fire and Materials, 16, 107-18 (1992).
- (9) Huggett, C., "Estimation of Rate of Heat Release by Means of Oxygen Consumption Measurements," Fire and Materials, 4, 1061-65 (1980).
- (10) Parker, W.J., "Calculations of the Heat Release Rate by oxygen Consumption for various Applications," NBSIR 82-2427-1, 1982.
- (11) Parker, W.J., "Calculations of the Heat Release Rate by Oxygen Consumption for various applications," Journal of Fire Sciences, 2, September/October, pp. 380-95 (1984).
- (12) ISO/CD 13927, "Plastics - Simplified Heat Release Test Using a Conical Radiant Heater," International Standards Organization Technical Committee 61, Subcommittee 4, Geneva Switzerland.
- (13) Horrocks, A.R. and Kandola, B.K., "The Use of Intumescent to Render Flame Retardant Cotton Fibres More Effective," in BCC Eighth Annual Conference on Flame Retardancy, June 2-4, 1997, Stamford, CT.
- (14) Kandola, B.K. and Horrocks, A.R., "Determination of Thermal Barrier Properties of Fibre/Intumescent Textile Composite Systems Using Mass Loss Calorimetry," in BCC Tenth Annual Conference on Flame Retardancy, May 24-26, 1999, Stamford, CT.
- (15) Caldwell, D.J. and Alarie, Y.C., "A Method to Determine the Potential Toxicity of Smoke from Burning Polymers: I. Experiments with Douglas Fir," J. Fire Sciences, 8, 23-62 (1990).
- (16) Caldwell, D.J. and Alarie, Y.C., "A Method to Determine the Potential Toxicity of Smoke from Burning Polymers: II. The Toxicity of Smoke from Douglas Fir," J. Fire Sciences, 8, 275-309 (1990).
- (17) Caldwell, D.J. and Alarie, Y.C., "A Method to Determine the Potential Toxicity of Smoke from Burning Polymers: III. Comparison of Synthetic Polymers to Douglas Fir Using the UPitt II Flaming Combustion/Toxicity of Smoke Apparatus," J. Fire Sciences, 9, 470-518 (1991).
- (18) Grayson, S.J. and Trew, R., personal communication, 1998.

ASTM International takes no position respecting the validity of any patent rights asserted in connection with any item mentioned in this standard. Users of this standard are expressly advised that determination of the validity of any such patent rights, and the risk of infringement of such rights, are entirely their own responsibility.

This standard is subject to revision at any time by the responsible technical committee and must be reviewed every five years and if not revised, either reapproved or withdrawn. Your comments are invited either for revision of this standard or for additional standards and should be addressed to ASTM International Headquarters. Your comments will receive careful consideration at a meeting of the responsible technical committee, which you may attend. If you feel that your comments have not received a fair hearing you should make your views known to the ASTM Committee on Standards, at the address shown below.

This standard is copyrighted by ASTM International, 100 Barr Harbor Drive, PO Box C700, West Conshohocken, PA 19428-2959, United States. Individual reprints (single or multiple copies) of this standard may be obtained by contacting ASTM at the above address or at 610-832-9585 (phone), 610-832-9555 (fax), or service@astm.org (e-mail); or through the ASTM website (www.astm.org).