



## Standard Guide for Room Fire Experiments<sup>1</sup>

This standard is issued under the fixed designation E 603; the number immediately following the designation indicates the year of original adoption or, in the case of revision, the year of last revision. A number in parentheses indicates the year of last reapproval. A superscript epsilon ( $\epsilon$ ) indicates an editorial change since the last revision or reapproval.

### INTRODUCTION

This guide has been written to assist those planning to conduct full-scale compartment fire experiments. There are many issues that should be resolved before such an experimental program is initiated, and this guide is written with the objective of identifying some of these issues and presenting considerations that will affect each choice of procedure.

This guide deals with any or all stages of fire growth in a compartment. Whether it is a single- or multi-room experiment, observations can be made from ignition to flashover or beyond full-room involvement.

One major reason for conducting research on room fires is to learn about the room fire buildup process so the results of standard fire test methods can be related to performance in full-scale room fires, allowing the further refinement of these test methods or development of new ones.

Another reason concerns computer fire modeling. Full-scale tests can generate data needed for modeling. Comparisons of modeling with full-scale test results can serve to validate the model.

The various results among room fire tests reflect different experimental conditions. The intent of this guide is to identify these conditions and discuss their effects so meaningful comparisons can be made among the room fire experiments conducted by various organizations.

### 1. Scope

1.1 This guide addresses means of conducting full-scale fire experiments that evaluate the fire-test-response characteristics of materials, products, or assemblies under actual fire conditions.

1.2 It is intended as a guide for the design of the experiment and for the use and interpretation of its results. The guide is also useful for establishing laboratory conditions that simulate a given set of fire conditions to the greatest extent possible.

1.3 This guide allows users to obtain fire-test-response characteristics of materials, products, or assemblies, which are useful data for describing or appraising their fire performance under actual fire conditions.

1.3.1 The results of experiments conducted in accordance with this guide are also useful elements for making regulatory decisions regarding fire safety requirements. The use for regulatory purposes of data obtained from experiments conducted using this guide requires that certain conditions and criteria be specified by the regulating authority.

1.4 The rationale for conducting room fire experiments according to this guide is shown in 1.5-1.8

1.5 Room fire experiments are a means of generating input data for computer fire models and for providing output data with which to compare modeling results.

1.6 One of the major reasons for conducting room fire experiments is as an experimental means of assessing the potential fire hazard associated with the use of a material or product in a particular application. This should be borne in mind when designing nonstandard experiments.

1.7 A rationale for conducting room fire experiments is the case when smaller-scale fire tests inadequately represent end-use applications.

1.8 A further rationale for conducting room fire experiments is to verify the results obtained with smaller scale tests, to understand the scaling parameters for such tests.

1.9 *This standard is used to measure and describe the response of materials, products, or assemblies to heat and flame under controlled conditions, but does not by itself incorporate all factors required for fire hazard or fire risk assessment of the materials, products, or assemblies under actual fire conditions*

---

<sup>1</sup> This guide is under the jurisdiction of ASTM Committee E05 on Fire Standards and is the direct responsibility of Subcommittee E05.13 on Large Scale Fire Tests.

Current edition approved October 10, 2001. Published November 2001. Originally published as E 603 – 77. Last previous edition E 603 – 98a.

1.10 *This standard does not purport to address all of the safety concerns, if any, associated with its use. It is the responsibility of the user of this standard to establish appropriate safety and health practices and determine the applicability of regulatory limitations prior to use.*

## 2. Referenced Documents

### 2.1 ASTM Standards:

D 4442 Test Methods for Direct Moisture Content Measurement of Wood and Wood-Base Materials<sup>2</sup>

D 4444 Test Methods for Use and Calibration of Hand-Held Moisture Meters<sup>2</sup>

D 5424 Test Method for Smoke Obscuration of Insulating Materials Contained in Electrical or Optical Fiber Cables When Burning in a Vertical Cable Tray Configuration<sup>3</sup>

D 5537 Test Method for Heat Release, Flame Spread and Mass Loss Testing of Insulating Materials Contained in Electrical or Optical Fiber Cables When Burning in a Vertical Cable Tray Configuration<sup>3</sup>

E 176 Terminology of Fire Standards<sup>4</sup>

E 800 Guide for Measurement of Gases Present or Generated During Fires<sup>4</sup>

E 906 Test Method for Heat and Visible Smoke Release Rates for Materials and Products<sup>4</sup>

E 1321 Test Method for Determining Material Ignition and Flame Spread Properties<sup>4</sup>

E 1354 Test Method for Heat and Visible Smoke Release Rates for Materials and Products Using an Oxygen Consumption Calorimeter<sup>4</sup>

E 1355 Guide for Evaluating the Predictive Capability of Deterministic Fire Models<sup>4</sup>

E 1537 Test Method for Fire Testing of Real Scale Upholstered Furniture<sup>4</sup>

E 1590 Test Method for Fire Testing of Mattresses<sup>4</sup>

Proposed ASTM Room Fire Test for Interior Finish Materials<sup>5</sup>

### 2.2 UL Standards:

UL 1715 Room Corner Test<sup>6</sup>

UL Subject 1040 Large Scale Open Corner Test<sup>6</sup>

### 2.3 ICBO Standards:

Uniform Building Code Standard UBC 8-2 Standard Test Method for Evaluating Room Fire Growth Contribution of Textile Wallcoverings<sup>7</sup>

Uniform Building Code Standard UBC 26-3 Room Fire Test Standard for Interior of Foam Plastic Systems<sup>7</sup>

### 2.4 FM Standard:

FM 4880 Large Scale Open Building Corner Test<sup>8</sup>

### 2.5 ISO Standards:

ISO/IEC Guide 52 Glossary of Fire Terms and Definitions<sup>9</sup>

ISO 3261 Fire Tests—Vocabulary<sup>9</sup>

ISO 9705 Fire Tests—Full Scale Room Fire Tests for Surface Products<sup>9</sup>

### 2.6 NFPA Standard:

NFPA 265 Methods of Fire Tests for Evaluating Room Fire Growth Contribution of Textile Wall Coverings<sup>10</sup>

## 3. Terminology

3.1 *Definitions*—For definitions of terms used in this guide and associated with fire issues, refer to the terminology contained in Terminology E 176, ISO/IEC Guide 52, and ISO 3261. In case of conflict, the terminology in Terminology E 176 shall prevail.

3.1.1 *heat release rate, n*—the heat evolved from the specimen, per unit of time.

3.1.2 *oxygen consumption principle, n*—the expression of the relationship between the mass of oxygen consumed during combustion and the heat released.

3.1.3 *smoke obscuration, n*—reduction of light transmission by smoke, as measured by light attenuation.

### 3.2 Definitions of Terms Specific to This Standard:

3.2.1 *full-scale test, n*—a test in which the product(s) to be tested is utilized in the same size as in its end use.

3.2.1.1 *Discussion*—In practical applications, this term is usually applied to tests where the item to be tested is larger than would fit in a bench-scale test.

3.2.2 *total heat released, n*—integrated value of the rate of heat release, for a specified time period.

## 4. Summary of Guide

4.1 This guide does not define a standard room fire test. It does, however, set down many of the considerations for such a test, for example, room size and shape, ventilation, specimen description, ignition source, instrumentation, and safety considerations that must be decided on in the design of a room fire experiment. It discusses performance criteria for the particular array of finishing and furnishing products that comprise the room. The behavior of any particular product in the room depends on the other products and materials present and how they are arranged in relation to one another.

4.2 Whether a particular arrangement simulates the evaluation desired depends on the size and location of the ignition source. It is therefore important that the ignition source simulate, insofar as possible, an initiating fire for the desired scenario.

4.3 The main criterion suggested in this guide for evaluating fire performance is based on the time to flashover as indicated by the time at which the radiation flux at the center of the floor exceeds 20 kW/m<sup>2</sup>. Other suggested indicators of flashover include an average upper air temperature in excess of 600°C and the ignition of a cotton indicator. Other possible performance criteria include the total amount or rate of smoke and

<sup>2</sup> Annual Book of ASTM Standards, Vol 04.10.

<sup>3</sup> Annual Book of ASTM Standards, Vol 10.02.

<sup>4</sup> Annual Book of ASTM Standards, Vol 04.07.

<sup>5</sup> Discontinued—See 1982 Annual Book of ASTM Standards, Part 18, pp. 1618 – 1638.

<sup>6</sup> Available from Underwriters Laboratories, Inc., 333 Pfingsten Rd., Northbrook, IL 60062.

<sup>7</sup> Available from International Conference of Building Officials, 5360 Workman Mill Rd. Whittier, CA 90601.

<sup>8</sup> Available from Factory Mutual Research Corporation, 1151 Boston-Providence Turnpike, P.O. Box 9102, Norwood, MA 02662.

<sup>9</sup> Available from International Organization for Standardization, P.O. Box 56, CH-1211, Geneva 20, Switzerland.

<sup>10</sup> Available from National Fire Protection Association, Batterymarch Park, Quincy, MA 02269.

heat production, extent of the flame spread for a low-energy ignition source, and size of the primary ignition source required to produce flashover.

4.3.1 Where multi-room experiments are being conducted, flashover may not be an appropriate performance criteria. In fact, the experiments may have to be conducted beyond flashover. Post-flashover is usually required in the test room in order to observe high levels of toxic gases and smoke in remote rooms or flame spread in adjoining surface areas. Other performance criteria could be the levels of combustion products that impair visibility and cause incapacitation or lethality in remote rooms.

4.4 Primary ignition sources include gas burners, wood cribs, waste containers, and pools of liquid fuel. Waste containers and wood cribs have the advantage of presenting a solid fuel fire with some feedback effects and a luminous flame that appears to simulate the burning of furniture. However, the gas burner is the best choice for most fire experiments because of its reproducibility. The placement of the ignition source depends on the desired effect on the target material.

4.5 The instrumentation for measuring burning rate, heat release rate, heat flux, temperature, upper layer depth, air velocity, flame spread, smoke, and gas concentration is discussed, along with suggested locations. A minimum level of instrumentation is also suggested.

4.6 A typical compartment size is 2.4 by 3.7 m (8 by 12 ft), with a 2.4-m (8-ft) high ceiling. A standard-size doorway (0.80 by 2.0-m high) should be located in one wall, probably in one of the shorter ones. The top of the doorway should be at least 0.4 m (16 in.) down from the ceiling to partially contain smoke and hot gases.

4.7 Insofar as possible, the construction details of the wall and ceiling, as well as any enclosed insulation, should duplicate the room being simulated. Boundary surfaces that do not form the specimen should also be constructed of materials consistent with the room being simulated (see 6.2.3).

4.8 The safety of observers and the crew extinguishing the fire is emphasized strongly in this guide.

4.9 The analysis of data should include a comparison of the critical times, heat fluxes, temperatures, heat release rate, and smoke generation in the room with ignition, flame spread, and smoke properties of the specimen materials. This would aid in the development or modification of small-scale tests and would provide useful information for assisting in the development of analytical room fire models.

## 5. Significance and Use

5.1 This guide provides assistance for planning room fire tests. The object of each experiment is to evaluate the role of a material, product, or system in the fire growth within one or more compartments.

5.2 The relationship between laboratory fire test methods and actual room fires can be investigated by the use of full-scale and reduced-scale experiments. This guide is aimed at establishing a basis for conducting full-scale experiments for the study of room fire growth.

## 6. Experimental Choices

6.1 *General*—The complete program for any series of full-scale compartment fire experiments usually involves many different considerations and possible simulations. This guide reflects the current state of knowledge and suggests choices for geometry, ignition sources, and instrumentation.

### 6.2 *Compartment Design:*

#### 6.2.1 *Ventilation:*

6.2.1.1 Experiments with ventilation-controlled fires in model rooms (1),<sup>11</sup> where the fire has become large or reaches the point of flashover, show that the compartment geometry and dimension influence the burning rate. An important relationship is the following:

$$\dot{m} = kA\sqrt{H} \quad (1)$$

where:

$\dot{m}$  = mass loss rate (kg/s),

$A$  = area of the ventilation opening (m<sup>2</sup>),

$H$  = height of the ventilation opening (m), and

$k$  = a proportionality constant, the value of which is approximately 0.09 kg/m<sup>5/2</sup> s.

This equation is an empirical relationship resulting from the classic ventilation-controlled wood crib fires that Kawagoe (2) studied. Other experiments by Hagglund (3) reveal that flashover was not observed for  $A\sqrt{H}$  below 0.8 m<sup>5/2</sup>. Hagglund conducted experiments on wood cribs in a compartment measuring 2.9 by 3.75 by 3.7-m high. These studies suggest that a limiting burning rate that depends on the ventilation must be exceeded before flashover occurs. The correlation is useful as a guideline for the occurrence of flashover.

6.2.1.2 However, later studies show that the rate of burning becomes independent of ventilation at flashover. Also, a single item with a large enough burning rate can induce flashover. Among other parameters, ventilation plays an important role in fire severity. Drysdale (4) explores many of these parameters in detail.

6.2.1.3 Ventilation should be continuous in a multi-room test facility. The doors may be either open or partially closed. One can install a typical heating ventilation and air conditioning (HVAC) duct system if the compartments are closed.

#### 6.2.2 *Size and Shape of Compartment:*

6.2.2.1 The geometry of the compartment in conjunction with the thermal properties of the wall and ceiling materials has substantial influence on the behavior of a confined fire, particularly by affecting flow patterns, and hence the mixing and combustion characteristics of the fire. Thus, the compartment size, shape, and openings should be chosen to simulate the nature or type of compartment or facility in which the subject material, product, or system is expected to be used in actual service. If there is a range of sizes, account should be taken of the fact that for a given ignition exposure, the smaller compartment sizes will usually provide the most severe fire development conditions. However, it has been found that room size (if the floor area lies between 8.7 and 11.4 m<sup>2</sup> and one of

<sup>11</sup> The boldface numbers in parentheses refer to the list of references at the end of this guide.



the room floor dimensions is between 2.4 and 3.7 m) has little effect on heat development if the heat release rate is below 600 kW (5). The compartment should preferably be designed to be symmetrical and as simple as possible for ease of analysis. The proposed ASTM Room Fire Test for Interior Finish Materials is based on a 2.4 by 3.7-m (8 by 12-ft) room with a 2.4-m (8-ft) high ceiling. It has one standard-size doorway left fully open. The space between the top of the door and the ceiling is critical because of the trapping of smoke and hot gases. It is 0.4 m (16 in.) in the proposed ASTM room. The room dimensions may be chosen to simulate some particular applications. However, if there are no constraints, it would probably be better to remain within the dimensions of the proposed ASTM room for possible comparison with other single compartment tests. Also, the proposed ASTM room is already setup and instrumented in many commercial testing laboratories. The room should be located inside a larger, carefully ventilated enclosure to ensure minimum interference from drafts or wind currents. Ref (6) shows how doorway size and room geometry affect fire growth. In order to measure many of the properties that are required from room-sized tests, a canopy hood and exhaust duct are required. These are usually placed either in the room itself, or more commonly, just outside the doorway (see Fig. 1).

6.2.2.2 Examples of tests that use full rooms are Test Methods D 5424, D 5537, E 1537, and E 1590, and UL 1715, UBC 8-2 and 26-3, and ISO 9705, as well as the proposed ASTM room test.

6.2.2.3 In a multi-room test, it is critical to duplicate the size and location of corridors and remote rooms. If flame spread along walls is being observed, it may not matter if the corridor has a closed end; it does matter when the flame spread on the floor is important. It has been shown that closing the corridor has very important effects on gas flow and decay of gases (7, 8).

6.2.3 *Thermal and Radiative Properties of Compartment Linings:*

6.2.3.1 The fire gas temperature and heat flux levels in the fire compartment depend on the heat balance of the compartment (heat released during the combustion process and heat

lost to the bounding surfaces and transfer of thermal energy due to the net flow of hot gas from the room through natural ventilation or forced ventilation systems. Heat transfer to a bounding surface in the presence of flames occurs mainly by radiation and convection. The amount of radiant energy impinging on a surface depends on the radiative properties of the exposure fire and of the surrounding surfaces. The convective heat transfer rate is determined by the geometry of the bounding surface and the magnitude and turbulence associated with the gas flow in the compartment. Heat transfer, which affects the magnitude of heat flux acting on the bounding surface, is related directly or indirectly to both the size and shape of the compartment involved even though radiative properties of the materials contained in bounding surfaces are unrelated to geometrical issues. Consequently, the geometry, thermal and radiative properties, and degradation characteristics of the compartment surfaces should be considered carefully when conducting compartment fire experiments.

6.2.3.2 The thermal inertia (product of thermal conductivity, density, and heat capacity,  $k\rho c$ ) of the materials forming the linings of a fire compartment (bounding materials) directly affects their surface temperature, and its corresponding rise, the rate of heat dissipated into the internal surface, and the room gas temperature. The influence of the wall materials on the temperature distribution in the gas is also a function of the radiative properties of the gas and the gas velocity. Relevant nondimensional parameters which account for this coupled interaction have been published (9). If the thermal inertia is low (good insulation), the surface temperature rises more rapidly, the rate of heat transfer decreases, and the radiation emitted from the upper walls and ceiling to both the fire itself and the lower part of the compartment increases. The emissive power of surfaces and their temperatures are coupled through the radiative transfer equation. Bounding surfaces consisting of materials with good insulating properties will produce substantially higher gas temperatures in the room than when poor insulators are used for lining the enclosed space. The effect of compartment thermal properties on the time-temperature curve has been analyzed mathematically in the post-flashover regime with numerical methods (10-12). Full-scale studies demonstrate the effect of compartment wall properties on the fire intensity (13-15). Typical thermal property values of some samples of common materials are given in Table 1 (16) as guidance.

6.2.3.3 The radiative characteristics of the bounding surfaces influence the compartment gas temperatures, particularly during the pre-flashover stages of compartment fires, but this effect decreases with time (10). Bounding surfaces having a greater absorptivity result in a lower gas temperature in the fire compartment. However, the surface absorptivity effect is pronounced when good thermal conducting materials are used on the walls, ceiling, and floor and is of minor practical importance for the compartment lined with high-insulation materials.

6.2.3.4 Since the severity of a fire in its early stages will depend on the heat exchange with the bounding surfaces of the room, it is important that construction details, such as the wallboard thickness, type, size, and spacing of the studs and joists, and insulation, if any, in the wall and ceiling cavities, be

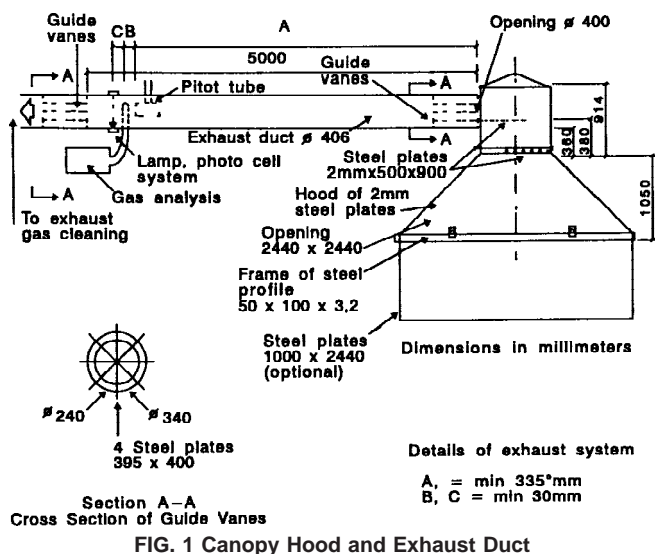

representative of the construction that is being simulated. For those areas of the interior surface not being tested, a suitable inert material may be a ceramic fiberboard that has thermal properties similar to those of gypsum board. (Tran and Janssens (15) have demonstrated that ceramic fiberboard is a very good insulator and can increase the severity of the test.) Gypsum and ceramic fiberboard give different results, and the results must not be intermixed. Gypsum is the material of choice for normal tests.

6.2.3.5 During the course of a compartment fire experiment, the disintegration or cracking, if any, of the materials lining the compartment will affect the behavior of the confined fire. Vertical pressure gradients developed in the presence of the fire will cause smoke and hot gases to leak to the outside and cool air to be drawn into the compartment through the cracks in the compartment walls or specimens.

### 6.3 Specimens:

#### 6.3.1 General:

6.3.1.1 In the room fire experiment, all of the combustible products in the room can be considered to be part of the specimen. When some of these products are combined to form an item of furnishing or a wall, the combination becomes the specimen. In fact, the walls, ceiling, floor, and all of the furnishings constitute a configured specimen whose properties include the physical and chemical properties of the items and their location.

6.3.1.2 The following paragraphs deal with recommendations for the description and selection of specimens for the room fire experiments to ensure that the important variables will be considered, and to provide a basis of comparison between experiments conducted at different laboratories.

6.3.2 *Description*—As much information as possible should be secured and reported for the materials, products, and assemblies in order to provide the necessary information on the room fire specimen. Along with a description of the ventilation conditions and ignition source, the data are intended to provide the input necessary to estimate the degree of involvement of the various combustibles and the maximum rise in the upper air temperature that could potentially be attained.

6.3.2.1 The specimen should be divided into components classified either as finishing materials, wall and floor coverings, or furniture.

6.3.2.2 The location of the material, product, or assembly to be tested as a lining should be specified as in one or more of the following zones: (1) ceiling, (2) upper half of wall, (3) lower half of wall, (4) floor, or (5) fraction of a zone, for screening purposes. Both combustible and noncombustible components are to be taken into account. The test standards addressing specific items, such as NFPA 265, give details of the locations to be used.

6.3.2.3 The chemical composition, generic or brand name of the lining material, and any involved adhesive interfaces, description of exposed area, thickness, density, moisture content, and fire properties of each component should be detailed. If possible, the thermal conductivity and specific heat should also be listed. Some fundamental fire properties of the material as determined by accepted test methods such as the cone calorimeter, Test Method E 1354, the OSU calorimeter, Test

Method E 906, or the LIFT apparatus, Test Method E 1321, reflect various aspects of the fire performance in a room fire. Data such as heat release, smoke release, ignitability, flame spread, etc. may assist in interpretation of the results of the room fire experiment. The ignition times, flame spread distance and rate, and heat release rates depend on many factors, such as the incident heat flux on the specimen and the type of flame. Hence, the exposure conditions during the room fire experiments should be described. If possible, the bench-scale fire tests should be performed on specimens that have the same thickness as the material used in the room temperature for thicknesses up to 50 mm (2 in.).

6.3.2.4 The location of items of furniture in terms of their distance from the wall, corner, and other furniture items should be identified in terms of their distance from the different walls, corners, and any other furniture items specified. For each furniture item to be tested, the horizontal and vertical exposed areas, total weight, and moisture content should also be described. It would also be helpful to indicate the material composition, if known. The test standards addressing specific items, such as Test Method E 1537, for upholstered furniture or Test Method E 1590, for mattresses, give details of the locations to be used.

6.3.2.5 The ambient temperature and humidity of the room and the time these conditions have been maintained prior to the experiment should be recorded.

6.3.3 *Selection*—The choice of the specimen is based on the objective of the room fire experiment, which may be one of three types: (1) a demonstration experiment, (2) a comparison of theory and experiment, or (3) a determination of the fire performance of a particular product.

6.3.3.1 In the demonstration experiment, the room should be finished and furnished in the most realistic way possible. Observations and measurements should be aimed at uncovering the important phenomena involved in the simulated room fire and at establishing possible levels of temperature, gas concentration, and times of occurrence, etc.

6.3.3.2 In the second type of room fire experiment, the emphasis is on the ease of description so that calculated values can be checked against the experimental results. The number of products in any given experiment should be minimized for simplicity of description. However, products covering a large range of properties should be selected for the tests so that the prediction formulas developed do not have limited applicability.

6.3.3.3 In the third type of experiment, to evaluate fire performance, the location of the comparison product in the room should be based on its intended use (that is, a ceiling, wall, floor, wall covering, or item of furniture). Because of heat-trapping effects, the ceiling material should cover the complete room ceiling. While it may not be necessary to cover the entire wall area with the wall product, the area covered by a wall product must be large enough to contain all wall areas exposed during the experiment and extend beyond the end of any expected flame spread. In general, other materials in the room should be noncombustible, or at least of low heat release, and should remain the same from experiment to experiment. Because of its widespread use and low heat release, gypsum

board is often used, but the board must be replaced between experiments in those areas in which it was exposed to fire. An alternative is ceramic fiberboard.

6.3.3.4 The experimenter may occasionally want to evaluate the outcome of the most severe ignition source and product orientations. It would be prudent for a caveat to be added to the conclusions of the experimental report stating that other ignition source strengths and material orientations were not considered and therefore could not be evaluated on the basis of the subject experiments.

6.3.3.5 Unless special considerations apply, the relative sizes of the product to be tested and of the ignition source should be such that only a fraction of the product to be tested should be consumed, if the product to be tested has good enough fire performance.

#### 6.3.4 *General Considerations:*

6.3.4.1 The distinction between materials located on the upper and lower walls is made because heat conduction losses occur primarily through the upper walls and ceiling. Increasing the insulation in these areas increases the rate of temperature rise in the room and the maximum temperature that will be reached.

6.3.4.2 The spacings between the items of furniture, along with the ignitability of the furniture, determine the probability and time of flame spread between them. When two or more items of furniture are burning, their separation distance determines whether the flames will merge. Furthermore, the heat transfer between them will enhance their separate burning rates so that larger flames will result. The proximity of the burning item of furniture to the wall and corner causes an increase in flame height with an attendant increase in air temperature and the probability of the flame jumping between the item and the wall.

6.3.4.3 In addition to its toxic effect and visibility problems, smoke is a factor in the heat radiative exchange between the upper and lower portions of the room. The height of the furniture items or wall covering material will determine the probability of their ignition by the hot air layer in the upper part of the room. Horizontal and vertical surface areas are therefore specified separately because of the difference in heat transfer from flames to surfaces with these orientations. These differences lead to different heat release rates and flame spread characteristics.

#### 6.4 *Ignition Sources:*

6.4.1 *General*—The choice of a primary ignition source in a compartment fire experiment is a critical item. This guide presents a list of the important considerations for the choice. There will always be compromises on the size, location, type of fuel, time of burning, type of burning, and other factors. This discussion will present some of the important considerations and various choices that can be made.

6.4.2 *Type and Size*—The complete character of the ignition source should be determined, including weight, material identification, morphology, dimensions, and all other physical and chemical characteristics that are necessary to repeat each ignition scenario. Typical ignition sources may be solid, liquid, or gaseous fuels and include wastebaskets, furniture items, wood cribs, gas burners, liquid pool fires, and liquid fuels

poured onto items of furnishings. The size is strongly dependent on the degree of fire buildup required for the experiment and the combustibility of the materials used in the experiment. When choosing an ignition source for a particular experiment, the characteristics of the product to be tested (size and heat production capability) should be taken into account, so as to make a reasonable selection.

6.4.2.1 Gas burner flames have the following characteristics: (1) they are reproducible; (2) they are well-defined (that is, their heat production rate is determined readily from the gas flow rates); (3) they can be varied with time to represent the burning of different items of furniture or be maintained constant to facilitate analytical studies; (4) their burning rates are not influenced by heat feedback (unless controlled artificially); (5) the radiation properties of the flames are different than those of the product simulated; and (6) gas flames do not resemble what is seen in real fires.

6.4.2.2 Differences between diffusion and premixed burners should be recognized. For example, the flames from a premixed burner will be shorter and have lower emissivities. In order to avoid locally high velocities, the gas can be delivered through a large-area diffusing surface, such as a porous plate or a layer of sand.

6.4.2.3 Liquid fuel pool fires have the following characteristics: (1) their rate of fuel production is determined readily from their rate of mass loss or the flow rate necessary to maintain a constant depth in the pool; (2) they have an interaction with the fire environment that can be quantified by their change in heat production rate; (3) they are reproducible under the same exposure conditions; (4) their radiation characteristics can be controlled by the choice of fuel; (5) the effect of feedback is not quantitatively the same as that for furnishings; and (6) they lack visual realism unless they are intended to represent liquid fuel spills. A variation of the liquid pool fire is obtained by supplying the liquid fuel in a matrix of sand in order to vary its burning rate.

6.4.2.4 The solid fuels that have been used as ignition sources for room fire experiments have included primarily waste containers and wood cribs, with the latter having the longest history. Stick size, type of wood and spacing, as well as total mass have a large effect on the burning rate of the wood cribs. The use of the above two types of solid fuels is emphasized in this guide because they have been used the most up to the present time. However, the reproducibility and precisely known heat output of a gas burner makes it a likely candidate for replacement of the cribs and waste containers for standard room fire experiments when detailed heat balances must be obtained from the experiments. Waste container and wood crib fires have the following advantages: (1) they provide the best visual simulation of the burning of furniture; (2) their interaction with the environment of the fire room is perhaps closer to, though not the same as, that of the burning furniture; and (3) their radiation characteristics more nearly match those of the furniture fire. Waste containers and wood cribs have the following disadvantages: (1) their reproducibility is not as good as that of gas burners and (2) the ratio of their heat release rates to their measured mass loss rates vary throughout the test.



6.4.2.5 Both the National Institute of Standards and Technology (NIST, formerly the National Bureau of Standards (NBS)) and the University of California, Berkeley, laboratories have used plastic waste containers as ignition sources in compartment fire experiments (17, 18). The combustibles within these waste containers have been plastic-coated paper milk cartons, paper tissues, carbon paper, paper towels, or kraft wrapping paper, or some combination thereof. Plasticized paper milk cartons make a relatively intense fire, as shown by burning rate, plume temperature, and heat flux. The milk cartons represent a combination of a cellulosic and a hydrocarbon-based polymeric material with a high surface-to-volume ratio comparable to the contents of a typical waste container in an American home.

6.4.2.6 If an ignition source is kept small, so that it does not cause flashover by itself, it can then be used to determine the effect of furniture or wall, ceiling, or floor covering on fire development in that compartment. The maximum size of an ignition source that should be chosen is thus dependent on the size, shape, and ventilation of the compartment as well as the location and burning characteristics of the ignition source itself. The size of the ignition source also depends on the scenario to be investigated.

6.4.2.7 It has been determined that the rate of heat release in a ventilation-controlled fire is proportional to  $A\sqrt{H}$  (6.2.1). For a typical fire scenario, the ignition source heat release rate should be less than 15 % of that estimated to produce flashover in the burn room. The size of the ignition source should not repress the contribution of the product that is being tested. When using gas burners, or a pool fire, the flow rate can be adjusted so that it does not cause flashover by itself. Other items used as ignition sources, such as furniture, can be tested in calorimeters to determine the heat release rate prior to actual testing.

6.4.2.8 Ignition sources are characterized by the following categories: (1) total fuel content; (2) type of fuel content; (3) rate of fuel release as a function of time; (4) rate of heat release as a function of time; (5) height of flame for given position (that is, corners, wall, etc.); (6) direct use of convective and radiative heat flux; and (7) time of burning. These characteristics can be determined for a variety of ignition sources, and the compartment experiment can be initiated with the appropriate source. Then, if a given ignition source does not lead to full room involvement with a given wall lining or to burning in a piece of furniture, when the intent is to determine the threshold size of the ignition source required to produce flashover, the intensity of the ignition source can be increased for the next experiment. Typical heat release rates as a function of time for larger sources have been reported (19, 20). For more data, the user should refer to Gross (21), Babrauskas, et al. (22), Holmlund (23), and Ahonen, et al. (24).

6.4.2.9 The designer of any experiment would be wise to explore the effect of a variety of ignition sources in the experimental arrangement. A 9.1-kg (20-lb) wood crib might cause full room involvement in a very small compartment, while a 22.7-kg (50-lb) crib would be necessary for a larger compartment lined with identical material. In one set of Underwriters' Laboratories full-scale room burns (25) using a

2.4 by 3.7-m (8 by 12-ft) enclosure with a 2.4-m (8-ft) ceiling and a standard-size door opening, a 1.4-kg (3-lb) waste container located in one corner was sufficient to cause full involvement of the room when it was lined with a high flame spread foam, but not with low flame spread foams. An overstuffed chair with cotton padding was found to have a burning rate equivalent to a 6.4-kg (14-lb) crib (18). In that same study, when two 1.8 by 2.4-m (4 by 8-ft) panels of the specimen material formed one corner of a 3.0 by 3.0-m (10 by 10-ft) experimental room, the 6.4-kg crib located in the same corner was able to cause flashover with plywood and particle board but not with the wood fiber insulating board. A report by Quintiere and McCaffrey (26) illustrates the effect of various cribs and ventilation sizes on fire intensity.

6.4.2.10 Relatively large-dimension open corner room configurations, consisting of one long wall, one short or end wall, and an included horizontally oriented ceiling, have been standardized and codified as proprietary test methods by Underwriters' Laboratories and by Factory Mutual Research Corporation (UL 1040 and FM 4880).

6.4.3 *Location*—The location of the ignition source is one of the most important considerations when conducting compartment experiments. Fig. 2 shows schematically how the flame height from a given ignition source increases when placed against a wall and in the corner. Also, the flame height is strongly dependent on the proximity of the ignition source to each wall. The distance from the wall might be set at 25 or 50 mm (1 or 2 in.). See Babrauskas (27) and Thomas, et al. (28) for more detail.

6.4.3.1 The simplest model of combustion of an ignition source is given by Lie (29), wherein he notes that, although the combustion process is determined by a large number of parameters, all of these parameters are related to the three essential elements of fuel, heat, and air. The estimated height of flames has been the subject of many studies (30-33), but in general it can be simplified to a relationship in which flame height is governed by the entrainment of air into the flame plume. If the access of air to the flame is blocked from one side, such as would occur by placing the ignition source against a wall, then one would expect a higher flame for the same rate of gaseous fuel leaving the source. This analogy can be extended further to an ignition source in a corner in which the two walls block air access from two sides. This gives the longest flame extension compared to either the free-burning source or that against a wall. Because of this result, the normal practice is to make the corner the standard location for the ignition source for the room fire experiments when the lining material is intended to become involved first. The ignition source should be placed directly in contact with an item of furnishing if that is to be involved first. In the case of a liquid fuel ignition source, it may be desirable to pour the fuel directly onto the item of furnishing.

6.4.3.2 The imposition of a ceiling on the flame plume of an ignition source has a very special effect on the combustion of the fuel. Entrainment of ambient air into the fire plume is decreased sharply when the plume turns the corner and becomes a ceiling jet. Such decreased entrainment leads to an increase in flame lengths since more flame surface is necessary

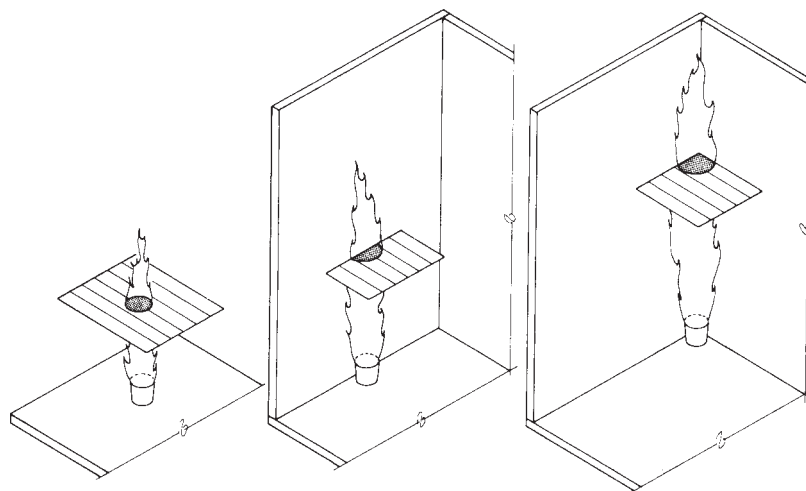

(a) In the center of the test area (b) At one wall (c) At the corner  
**FIG. 2 Schematic Diagrams of Ignition Sources (Note the change of flame height shown)**

to consume the fuel vapor delivered by the plume. This special feature of ceiling jets has been discussed by Alpert (34, 35). The net result of the interaction of the flame plume and the ceiling is shown schematically in Fig. 3, in which the flame plume is represented as having a height  $L_2$  above the ceiling line in the absence of a ceiling, but spreading a distance  $L_1$  under a ceiling. It has been noted by P. H. Thomas that the ratio of  $L_1$  to  $L_2$  may be as large as 6 or 7:1, but this does not appear to have been measured systematically for a range of fuels, ceiling materials, and boundary configurations. In any event, the use of ignition sources that produce flame heights substantially higher than the compartment ceiling may lead to flash-over and sustained involvement with only minimal combustion of the specimen material.

6.4.4 *Burning Characteristics*—A description should be given of calibration experiments performed with linings that do

not contribute significantly to a fire. These experiments are conducted with the same ignition source, and the following parameters should be recorded as a function of time: ceiling temperatures, mass loss rate, heat flux as a function of distance, and observed flame height.

6.5 *Instrumentation:*

6.5.1 *Calibration:*

6.5.1.1 Instruments must be calibrated carefully with standard sources both before and after the room fire test. Among these are the load cells or weighing platforms, heat flux gages or radiometers, smoke meters, flow or velocity transducers, gas burners, and gas composition analyzers. Most such calibrations can be conducted before the instrument is installed. Small, portable wind tunnels have been used successfully to calibrate anemometers. A portable black body is suitable only for calibrating narrow-angle heat flux transducers. Most of the heat

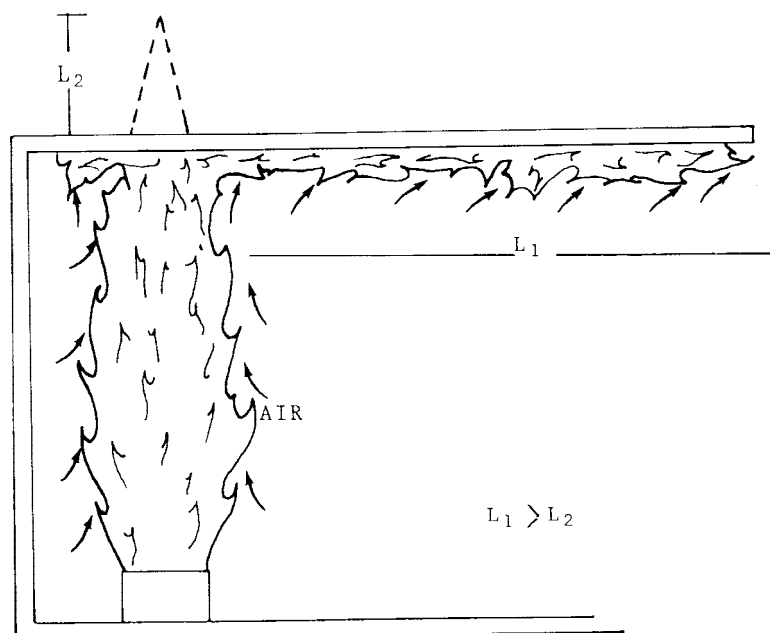

**FIG. 3 Flame Plume Under a Ceiling**



flux transducers used in room tests are of wide-angle type. Methods have been developed at NIST (36) and at the Swedish National Institute (37) for calibrating wide-angle heat flux transducers.

6.5.1.2 Even if the instrumentation has been calibrated, reliability can still be a problem. A small portion of the full-scale room should be set up and instrumented successively with the various transducers for this reason. A reliability check could be obtained by using gas burners in such a full-scale segment.

6.5.1.3 Quantities such as heat release, temperature, and heat flux cannot be measured with high precision in a fire environment. It is important not to report them with excessive significant figures.

6.5.2 *Heat Release Rate*—It is usually extremely important in a room-scale test to know the heat release rate of the fire throughout the experiment. Before the fire has spread significantly beyond the initial item, load cell or platform transducers can be used to determine the mass-time history of the primary burning specimen. Mass loss rate measurements cannot be converted directly to heat release rates due to the unknown heat of combustion of the volatiles and the unknown completeness of the combustion reaction. Heat release rates are normally determined, fairly accurately and continuously, throughout a test by measuring the oxygen concentration and calculating the heat release rate by using the oxygen consumption principle (38). This requires the installation of a hood and an exhaust duct for collecting all of the combustion products leaving the fire room. Moreover, it requires measurement of the oxygen concentration, differential pressure in the duct, and temperature in the duct (the latter ones to determine mass flow rate in the duct). Increased accuracy of heat release measurements is obtained if carbon monoxide, carbon dioxide, and water are also measured in the exhaust duct. All exhaust duct measurements should be made at a location at which the stream is well mixed. This will occur at approximately six to ten pipe diameters downstream of the exhaust duct (see 6.6). The gas concentrations, along with the mass flow rate in the duct, can be used to calculate the heat release rate as described in Ref (38). Further details can be found in the corresponding test methods and in a textbook addressing the subject of heat release in fires (39).

### 6.5.3 *Heat Flux:*

6.5.3.1 While knowing the total energy output of the fire is useful for evaluating a product's performance, determining the distribution of energy flux within the compartment is necessary in order to explain how fire spread occurs. The heat flux gages used in room fire tests should measure the total flux over a  $2\pi$  solid angle. Water-cooled Gardon-type and Schmidt-Boelter-type gages with black receiving surfaces are by far the most reliable and accurate of all flux transducers. With this type of gage, the flux incident on a surface from all sources can be measured. Reradiative or convective heat transfer from a surface near the gage can be estimated from surface temperature measurements. Thus the calculation of the net flux to the surface is allowed. Caution must be exercised, when using Gardon-type gages, to make measurements with a large con-

vective fraction as a result of calibration constant changes. Additional information is contained in the literature (40-42).

6.5.3.2 The importance of frequent cleaning, blackening, and recalibration should be stressed. The buildup of deposits on the foil of the Gardon gage will reduce sensitivity, and, unfortunately, this can occur during an experiment. The Schmidt-Boelter gage is less affected by deposits, generally more rugged, and somewhat more accurate because of the smaller surface temperature rise for a given flux. (This temperature is measured with a thermopile rather than a thermocouple.)

6.5.3.3 A better resolution of the source of the incident flux is obtainable from narrow-angle radiometers mounted outside the enclosure. These measurements can be compared directly with those from wide-angle heat flux gages by estimating overall radiating surface areas. Wide-angle (up to  $180^\circ$ ) radiometers with air-cooled windows are nearly impossible to construct; those obtainable have effective view angles of less than  $120^\circ$ , making it difficult to interpret the signal.

6.5.3.4 Spectral and angular effects on the transmission of the radiometer window, soot deposits on the window, and reradiation from the heated window to the foil make radiometers unsuitable for use in room fire experiments. Another method of heat flux measurement is obtained by imbedding one or more fine wire thermocouples, often with one at the exposed face. Numerical solution of the transient thermal conduction equations or the inverse heat conduction equations for the measured surface temperature time history then yields the net heat flux to the exposed surface. Temperatures at several depths within the material can be used to double-check the numerical result. What makes this method of heat flux measurement particularly desirable is that portions of the furniture, walls, and ceiling in the room satisfy all of the conditions necessary for solution of the conduction equations. Imbedded thermocouples at several wall and ceiling locations, especially near the ignition point, are also desirable as a means of determining the fire energy losses other than by convection and radiation through room openings.

6.5.3.5 There are four main areas in which sets of heat flux gages should be located during a compartment fire experiment. One location is as close as possible to the product or specimen initially ignited. Such a heat flux measurement will enable the radiative environment of the burning fuel to be determined, and this information is useful for evaluating the flammability of materials. A second heat flux gage location should be at any fuel specimen likely to become involved as a result of the gradual fire spread to contiguous or nearby materials. This measurement will be useful for evaluating the ignitability of fuel in the fire environment. Heat flux gages more remote from the primary fire but still within the compartment constitute a third group, which can be used to determine when general room involvement occurs. Such measurements should be made near the floor level. Finally, heat flux gages mounted outside the compartment and viewing door or window openings will respond when the compartment fire becomes an active threat to other building areas.

### 6.5.4 *Temperature:*

6.5.4.1 Gas temperature measurements at locations throughout the compartment are obtained easily by the installation of fine wire (preferably 0.31-mm (0.005-in.) diameter), exposed-bead thermocouples. Such measurements will be relatively accurate and useful for thermocouple locations in the moving smoke layer both within the compartment and in the openings. Radiation errors can be significant for thermocouples in view of flames or within optically thin flame zones. The magnitude of the radiation error can be determined by measuring the temperature with different size wires or welded junctions and extrapolating to zero diameter wire or junction to determine the true temperature. One method for reducing these radiation errors is by the use of aspirated thermocouples (that is, thermocouples recessed slightly from one end of a tube, the other end of which is connected to a pump drawing approximately 8 dm<sup>3</sup>/min). The resulting air-flow over the thermocouple bead, approximately 5 m/s, is sufficiently high to allow accurate temperature measurement based on the thermocouple voltage alone, even within flame zones. Because of the difficulty associated with their installation and maintenance throughout the experiment, as well as their expense, aspirated thermocouples would normally be limited to critical locations. Errors are also introduced when the number of connections increases. The number of thermocouple connectors should be kept to a minimum.

6.5.4.2 Thermocouples should be placed at vertical intervals of 76 to 152 mm (3 to 6 in.) at the following locations: (1) within the fire plume of the ignition source, (2) near the center of the room, and (3) in any door or window opening. Individual thermocouples should also be located adjacent to all air velocity probes, optical density light paths, and heat flux gages.

6.5.4.3 When measuring a material surface temperature, the thermocouples should be placed with junctions in contact with the surfaces. The wires on either side of the junction should lie in contact with the surface for a length of at least 5 diameters in order to reduce heat conduction losses along the wires. In some cases, it may be appropriate to use a bonding material, in which case the bonding material should be specified as well as its method of application. However, the bonding material will affect the surface temperature to some extent. If possible, it is better to drill two tiny holes 10-mm apart normal to the surfaces. The junction would be located midway between the holes. The lead wires would be threaded through the holes and pulled tight.

6.5.5 *Air Velocity*—Air velocity is normally determined by means of the bidirectional flow probe. This probe is less affected by high temperature sensitivity problems and fouling from soot deposition than older techniques, such as pilot tubes. The probe basically consists of two large pitot tubes facing opposite directions. An electronic (variable capacitance) manometer connected to the probe then allows an accurate determination of flow velocity magnitude and of whether there is an inflow or outflow. While the probe itself is inexpensive, each pressure measurement channel is rather expensive. The cost can be reduced by the use of a fluid switch to connect several probes successively to a manometer. However, this slows down the data acquisition process, since time must be allowed for the pressure to equilibrate at each station. Texts by

Benedict (43) and Ower and Pankhurst (44) are excellent sources of information on temperature, pressure, and air flow measurements. Ducted air supplies or returns need to be monitored in the same way as other flows. Pressure differentials should also be measured between the compartment, air ducts, and exterior side of the compartment.

6.5.5.1 The traditional methods of measuring the air velocity used to be the hot wire or hot foil thermoanemometer for low-velocity cold air inflow in the lower part of the doorway and the pitot tube for the higher-velocity high-temperature outflow near the top of the doorway. Two problems that must be considered are the effects of thermal radiation on the thermoanemometer and sooting of the pitot tubes.

#### 6.5.6 *Fire Propagation:*

6.5.6.1 While the grid of gas, surface, and imbedded thermocouples will provide a detailed plot of pyrolysis and probably reaction zones, a photographic record of the fire is essential to establish flame spread rates and burning area clearly. In general, tests should be videotaped. The usefulness of the photographic record depends primarily on an accurate time synchronization with all other experiment measurements. For this purpose, one or more clocks synchronized with the data acquisition time system should be clearly in view of all cameras or integrated in the photographic or video system. Digital clocks are generally easier to read in photographs and movies. Also, a length-scale grid on one or more walls and doorway opening should be used. Resolution may be better with appropriate still photography.

6.5.6.2 Photographic records of the compartment fire can be supplemented by observation with audio recorders running continuously. A written listing of observations with time should be provided in the report of the experiment.

#### 6.5.7 *Smoke:*

6.5.7.1 The generation of rate of smoke during the fire is very important. The time history provides information on the rate of smoke buildup and therefore allows the average smoke concentration to be calculated for the compartments communicating with the fire area. The measurements are made by determining the attenuation of a light beam as it travels from the source to the target. A collimated light source and a photometer placed directly opposite to it is a typical arrangement. In the present state-of-the-art, the concentration of smoke is best measured by the extinction coefficient (45) using a laser source. A design of such a system, now commercially available, is shown in Fig. 4. Careful alignment between transmitting and detecting optics is necessary for optimal operation. The smoke generation rate can be obtained by measuring the extinction coefficient and flow of smoke. Possible locations of smoke measurements are the exhaust duct, vertical or horizontal within the room, and any door or window opening. At compartment openings, smoke measurements should be conducted at multiple intervals so that the measurement errors due to stratification effects can be minimized. In the exhaust duct, the measurements should be made at a location at which the flow is well mixed. Another possible optical smoke measurement system design is based on an incandescent light source (46). In selecting a system, it is

ASTM E 603 - 01

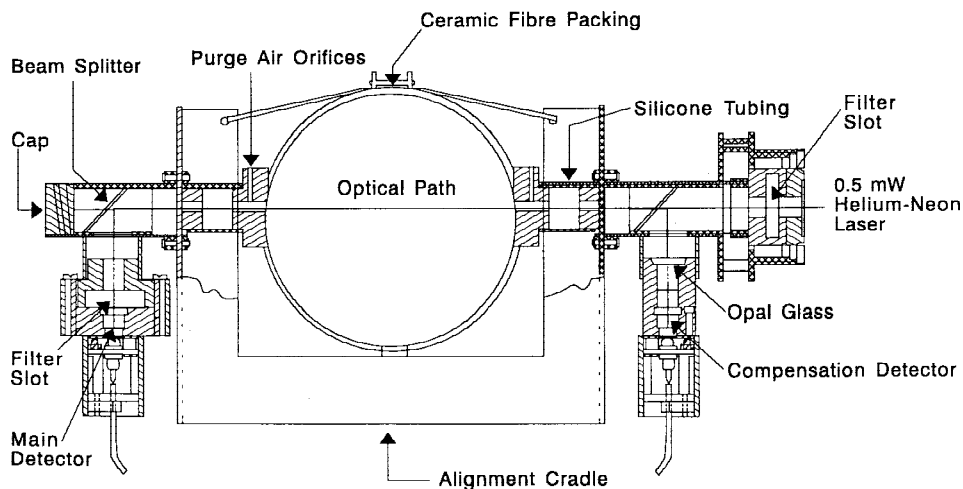

FIG. 4 Laser Extinction Beam

important to understand the nature of the measurement errors associated with it (47).

6.5.7.2 Changes in the intensity of a well-collimated light beam that may extend from floor to ceiling, pass horizontally across the room or doorway, or be limited to a few inches in length are used to measure the smoke. In choosing one or more path lengths for measurement, consideration should be given to the normal tendency of smoke to stratify, particularly in the early stages of a fire.

6.5.7.3 Deposition of soot within the optics is one of the large sources of error in smoke measurements. This can be overcome by providing a gentle flow of forced air to purge the system.

#### 6.5.8 Gas Concentrations:

6.5.8.1 Sampling probes should be located with the holes facing downstream, away from the inlet, to avoid clogging the holes with soot. The recommended designs of gas sampling probes are a ring sampler, such as that used in Test Method E 1537 or Test Method E 1590 (which also contains overall construction details), or a straight tube crossing the duct section, such as the recommended design in ISO 9705.

6.5.8.2 The measurement of oxygen is used to determine the rate of heat release in conjunction with the flow rate of smoke (see 6.5.2). Measurements of carbon dioxide, carbon monoxide, and water concentrations in the outgoing smoke can aid in the precision of calculations of rate of heat production in the room, for analysis of smoke toxicity and as indicators of combustion completeness.

6.5.8.3 For condensable combustion gases, heated sampling lines (150 to 175°C) should be used, to minimize losses through deposition. This includes many gases, except for carbon monoxide, carbon dioxide, and oxygen, notably hydrogen chloride (HCl), hydrogen cyanide (HCN), acrolein, ammonia, unburnt hydrocarbons, and water. The length of sampling lines should be kept to a minimum and made from non-reactive materials (for example, polytetrafluoroethylene). This inhibits the reactivity of the combustion products with the tubing material and concentration losses, typically occurring with hydrogen chloride (48 and 49). This information, along with that from a combustible products gas meter, can yield the

rate of fuel production and degree of combustion. Levels of carbon monoxide (CO), hydrogen chloride (HCl), hydrogen cyanide (HCN), and nitrogen oxides (NO<sub>x</sub>) account for the common toxic gas concentration components. The presence of a complex gas or gases that may be highly toxic in trace amounts requires the collection of grab samples that can be analyzed by mass spectrometry or gas chromatography, or both. Toxicity assessment may require bioassays and behavioral studies of exposed laboratory animals (see 6.5.9).

6.5.8.4 Oxygen concentrations are measured continuously with meters that respond to the paramagnetic properties of oxygen or with electrochemical cells, by a polarographic method.

6.5.8.5 Nondispersive infrared instruments are the most common technique used for recording the levels of carbon monoxide, carbon dioxide, and water continuously.

6.5.8.6 Measurements of water concentrations require heated filters, heated sampling lines, heated pumps, and heated cells in the analyzers, to avoid condensation. Moreover, it is more difficult to calibrate water analyzers than other analyzers. This can be solved with special calibration gases, but different calibration gases may be necessary for different analyzers. The measurement of water concentrations should be restricted to special circumstances, because of the experimental difficulties involved.

6.5.8.7 Gas sampling tubes that change color when samples of specific gases are drawn through them can be used to determine the approximate concentrations of a large number of combustion products, including carbon monoxide, carbon dioxide, HCl, HCN, and NO<sub>x</sub>. These gas sampling tubes generally have very low precision and should only be used as a rough guide. Comprehensive methods for measurement are provided in Guide E 800.

#### 6.5.9 Toxicity:

6.5.9.1 The toxic potency of smoke is a quantitative expression that relates smoke concentration and exposure time (that is, the exposure dose) to a certain adverse effect, on exposure of a test animal; the effect is usually lethality. The toxicity of smoke is a function of its composition, which, in turn, is dependent both on the material being burnt and the way in



which it is burnt. Thus, as the composition of the smoke generated from the same material in different tests can vary broadly, so will its toxic potency. It must be stressed that the toxic potency of smoke is also heavily dependent on the conditions under which the smoke has been generated, since the mode of generation will affect both the amount and type of combustion products being generated by the burning of any material.

6.5.9.2 Chemical analysis of smoke thus does not yield a comprehensive evaluation of all of the components in smoke. However, the toxicity of the smoke from the majority of common materials is usually described adequately by measurement of the concentrations of a very small number of individual toxicants. The most important of those are the carbon oxides (carbon monoxide and carbon dioxide) and low oxygen (which are present in all fires) and other gases such as hydrogen cyanide, hydrogen chloride, hydrogen bromide, and acrolein (50-54).

6.5.9.3 For some materials (very few), it has been shown that smoke toxicity is not well represented by the simple method described in 6.5.9.2. In that case, an adequate evaluation of smoke toxicity requires the use of laboratory animals.

6.5.9.4 If laboratory test animals are used in room fire experiments, place the animals within or near the compartment. Extract the smoke at a measuring point in the fire room and cool the smoke stream before exposing the animals, to avoid subjecting them to heat stress. If the smoke is cooled, the airborne concentration of those combustion products that decay in fire atmospheres (for example water soluble gases and solid particles) will decrease (7, 8) (see also 6.2.2.3 and 6.5.9.8). Thus, cooling the smoke is likely to result in a mixture of combustion products which is more representative of smoke at a location remote from the fire. It is also advisable to return the smoke to the fire room, after animal exposure, to retain the original fire room environment.

6.5.9.5 It is recommended that certain physiological characteristics of the animals be monitored, as well as determining the end point, which is usually lethality. Measurements that have been conducted include blood concentrations of carboxyhemoglobin, oxyhemoglobin and total hemoglobin, blood pressure, respiration rate, heartbeat rate, body temperature, and brain activity.

6.5.9.6 Gas analyses for carbon monoxide, carbon dioxide, oxygen, and halogen acids (typically HCl) are usually conducted at various sampling points, animal chambers, and the test room. The gas analysis data can be used to calculate the fractional effective dose (FED) of toxicity in the smoke. This method evaluates the combined effect of selected primary gases on humans and animals.

6.5.9.7 A complement to the chemical analysis of smoke is the measurement of toxic potency. The concentration of smoke ( $\text{kg/m}^3$ ) required to kill 50 % of the animals is the toxic potency measure, or  $\text{LC}_{50}$ . Animals are preselected for mortality studies; hereby, mortality is not only observed during the test but for 14 days after exposure as well. Several authors (50-54) discuss the significance of these measurements. In a similar fashion, incapacitation measures (for example, an  $\text{IC}_{50}$ ) can also be made.

6.5.9.8 A number of toxic gases decrease their concentration in fires by virtue of reactions with surfaces (for example, walls), with the most notable example being hydrogen chloride (55, 56).

6.5.9.9 The propensity for smoke (or combustion products) from any material or product to have the same effects on humans in fire situations as the effect it has on rats is only inferable to the extent that the rat is correlated with humans as a biological system.

#### 6.5.10 *Selection and Location of Instrumentation:*

6.5.10.1 The large array of instrumentation described in this guide is expensive. Thus, for research and development or demonstration experiments, some subset of instrumentation is likely to be used. The selection of such a subset should be made so as to satisfy the objectives of the experiment. However, a minimum amount of instrumentation is essential, even in a research experiment, so as to obtain data for the energy balance calculations necessary to adequately assess fire growth. These same measurements are necessary to establish exposure conditions for fire-test-response standards for ignition, flame spread or heat release. In a single room test, only one vent is necessary from which to measure the release rate. Appropriate locations for vent include the doorway and a window. In a multi-room facility, one appropriate site for measurements is the end of an adjoining corridor, where the effluents are directed. It is necessary to have data acquisition equipment, which can obtain data at intervals no longer than 6 s (at least in the periods of high activity), including an analog/digital converter and a computer that scans test activity. Details of instrumentation required for particular materials or products are given in the specific test methods.

6.5.10.2 A recommended set of measurements for a research experiment includes the following:

- (1) Oxygen concentration in the exhaust duct, to determine heat release (rates and amounts).
- (2) Burning rate of the item (or items) being tested, for example, by measuring their mass loss rate.
- (3) Burning rate of the ignition source.
- (4) Flame spread rates on objects or wall surfaces.
- (5) Smoke obscuration measurements in the exhaust duct.
- (6) Carbon dioxide and carbon monoxide concentrations of gas in the exhaust duct.
- (7) Continuous measurements of mass of any items being tested.

6.5.10.3 Other important measurements include the following:

- (1) Vertical air temperature profiles in the doorway and center of the room.
- (2) Surface temperature at the center of the ceiling and upper half of the walls.
- (3) Total heat flux measurements at the center of the floor, on the wall surface above the ignition source, and near the center of the ceiling.
- (4) Vertical air flow rates in the doorway (45).
- (5) Upper layer height.
- (6) Surface temperatures of target items.
- (7) Heat flux to target objects.
- (8) Ignition times of target objects.



(9) Gas concentrations.

6.5.10.4 Some measurements in the test room may also yield useful information. Examples are as follows:

(1) Carbon dioxide and carbon monoxide concentrations of the gas 0.025 m (1 in.) below the top of the doorway.

(2) Smoke measurements in the center of the room and doorway.

(3) Temperature measurements at various locations.

6.5.10.5 The foregoing measurements should be provided with time-tracked, photographic, or video coverage and with audio-recorded, visual observation of the fire as seen through the doorway.

6.5.10.6 Certification experiments and research experiments aimed at the development of materials might be limited to temperature measurements with photographic and visual observation.

#### 6.6 *Location of Instrumentation:*

6.6.1 The instrumentation in the exhaust duct should be located in such a way that the combustion products are well mixed and that there is a nearly uniform flow velocity across the duct cross section.

6.6.2 A minimum of six duct diameters is the recommended distance of straight duct, downstream from the last turn, before placing any measuring instrument. A minimum of four duct diameters is recommended after the last measuring instrument before placing any other fans or turns.

6.6.3 When flow velocity, smoke obscuration, and gas concentrations are measured, the recommended order in which the instrumentation is to be placed is as follows: velocity measurements followed by gas concentrations (including oxygen, for heat release) and smoke obscuration. A suitable separation between the different instruments is 0.3 m.

## 7. Procedure

### 7.1 *Safety Precautions:*

#### 7.1.1 *Prior to Experiment:*

7.1.1.1 Prior to performing the experiment, safety planning should occur and safety preparations should be made. The local fire department may be notified in advance. Technicians should be assigned in pairs and should have responsibility for one another during the period of the experiment. The size of the fire and the fuel loading should be considered and the following determinations made: (1) the primary and the backup method of extinguishment; (2) the expected toxic pyrolysis products and fire gases; (3) the potential for an explosion caused by a buildup of flammable gases such as carbon monoxide; (4) the most appropriate place for visiting observers and experiment personnel to be located; and (5) the ventilation necessary to remove toxic gases and limit the obscuration problem.

7.1.1.2 Extinguishment equipment, gas analyzers, protective clothing, breathing apparatus, medical first aid, and ventilation equipment should be provided based on these determinations. All observers and experiment personnel should be provided with appropriate protective clothing and safety eye-wear and should be briefed about the evacuation route. Properly lighted EXIT signs should be posted at appropriate places. Once all of these preparations have been made and just prior to ignition, the experiment site should be safety checked to verify that all extraneous materials have been removed from

the fire area, especially materials that could add fuel to the fire or cause tripping accidents during subsequent operations. A safety checklist should be prepared and used to ensure that all safety procedures are followed properly.

7.1.1.3 Careful consideration should be given to the electrical aspects of the experiment instrumentation and wiring. Wiring of the appropriate temperature rating should be used. Electrical circuitry is necessarily extensive in such an experimental arrangement, and care must be taken to avoid patchwork systems. In large projects, there is a tendency by some to use recognized unsafe practices with the excuse that they are temporary and everybody knows about them. Separate electrical circuits should be dedicated to each major phase of the experiment. Electrical service to the test room should be evaluated with special consideration for needs during extinguishment of fire.

7.1.1.4 The use of flammable liquids for ignition fuels or for aiding the ignition of other fuels should be watched closely. Where a large volume of gaseous fuel is used for the burner, a safety cutout device should be used to detect and cut off the supply of fuel to the burner. For example, a combination of a flame detector (flame rod) and a solenoid valve may be used for this purpose. While it is not reasonable to prohibit the use of certain materials in a research effort, a list might be prepared of materials, including indications of potential hazards and cautions for their use. For example, one of the flammable liquids that might be included in the list is heptane, a highly volatile substance that must be used with extreme caution. Heptane evaporates rapidly and propagates fumes over floor surfaces, which can be ignited easily, causing minor explosions. As such, all liquids must be stored in approved safety containers. Light fuel oils can be used more safely since they volatilize slowly at room temperatures; however, they are smokey. Absolute ethyl alcohol volatilizes moderately, burns cleanly, and can be used with relative safety. When such fuels are used for ignition, the containers should be removed from the experiment site prior to ignition.

7.1.1.5 Prior to and during an experiment, it is important that one individual have full authority with respect to safety considerations and experiment termination. This individual should have the responsibility of reviewing the experiment arrangement with respect to safety, as well as deploying personnel and reviewing the understanding of individual responsibilities. Prior to the conduct of the experiment, consideration should be given to means of controlling particulates and toxic gases in the outside enclosure. Experimental situations often generate considerable smoke, making visibility difficult, and accidents can occur easily.

7.1.2 *During the Experiment*—All experiment personnel should be in fire-retardant clothing with hard hats and safety glasses. Observers should be in protective clothing commensurate with their proximity to the fire. The extinguishing team should be ready, clothed in turn-out-coats, self-contained breathing apparatus, and fire helmets. All backup equipment should be readily accessible. Toxic gases and potentially explosive gases should be monitored throughout the experiment. A continuous assessment of the fire damage should be

made, with special attention given to any weakening of the structure that could permit falling debris.

#### 7.1.3 *After the Experiment:*

7.1.3.1 Extinguishment should begin as soon as possible after the necessary data are recorded. Electric power to items within the compartment must be cut off prior to entry of the extinguishing team. The primary extinguishing team should not engage the fire, however, until the backup equipment is charged and manned. All loose material should be pulled from the upper walls and overhead as the extinguishing crew approaches the fire. Forced ventilation should begin once the fire is extinguished completely. Known toxic gases should be monitored continuously from the very start of the experiment and up until their concentrations have returned to acceptable limits. All enclosed experiment sites should also be monitored for oxygen levels to preclude any oxygen starvation situations.

7.1.3.2 No one should enter the experiment area after the fire has been extinguished without a self-contained breathing apparatus and protective clothing until the room is thoroughly ventilated. Melts of synthetic materials should be handled carefully because of the possibility of retained heat and continuous generation of toxic products. The possible contamination with toxic gases and skin irritants should be considered for all materials taken from the experiment area. The experiment site should be watched for at least 1 h, to ensure complete extinction of the fire. Unexpected fires may occur from piles of smoldering, hot, and charred debris. Post-experiment cleanup may be facilitated by the use of a suitable disposal material laid on the floor if such would not be expected to alter the outcome of the experiment (see 6.2.3).

#### 7.2 *Observations and Data Gathering:*

##### 7.2.1 *Observations:*

7.2.1.1 The following critical times should be noted by an assigned observer during the test: (1) ignition of each separate combustible item in the room, including wall, ceiling, floor, furnishings, and combustible indicator panels, if used; (2) onset of flame passage through the doorway (flameover); and (3) sudden deformation or change in noncombustible items in the room.

7.2.1.2 The flame spread rate on the walls and ceiling, maximum flame travel distance from the ignition source, height of the lower boundary of the smoke layer passing out through the doorway, and degree of involvement of the various combustibles should also be noted periodically during the experiment. A grid premarked on the walls and ceiling will assist in estimating the flame spread rate. An audio recording in real time is one of the most efficient methods of documenting rapidly changing events. These observations should be backed up with video tape or photographic coverage whenever possible.

7.2.2 *Ambient Conditions*—Since the relative humidity of the air and moisture in the experiment materials may affect the experiment results markedly, measurements of ambient humidity and air temperature should be made for at least 12 h preceding the experiment. These ambient conditions should be measured both within the compartment and outside of the compartment just prior to the test. In addition, the moisture

content of the materials used should be recorded just prior to the test (follow the guidance in Test Methods D 4442 and D 4444).

##### 7.2.3 *Data Recording:*

7.2.3.1 It is not necessary to scan the data continuously, but it should be done at least every 15 s. If the system is variable, a more frequent scan may be required when rapid changes occur. Computer data acquisition equipment is highly recommended in the conduct of room fire tests. The analog output of all transducers should be read, processed, stored converted to digital output, and printed to screen every 6 s for up to 50 channels of data and every 10 s for up to 100 channels. The screen output serves as an on-the-spot reference of critical data. The 60-Hz noise should be filtered simultaneously. Recognizing that sharp peaks may be missed with this frequency of channel scanning, sophisticated equipment is available that is capable of scanning 100 channels per second. Alternatively, a few (up to 10) selected channels may be read every second by one economical data acquisition system while another system is scanning all other channels at a 6 s or greater interval.

7.2.3.2 If a computer data acquisition system as described in 7.2.3.1 is used, strip chart recorders become optional backup equipment for data acquisition. Although it is far better to have a second computerized system for backup, in a practical sense, it may not be feasible to have backup for every channel of data being collected by the computer system.

7.2.4 The mass loss of objects and materials in the room should be collected using load cells sized appropriately for the mass being measured. Care should be taken to protect the load cell and electrical wiring from excessive heat and radiation. These cells are highly temperature sensitive. Two other important factors that should be addressed are buoyancy effects and signal noise. Signal noise can be reduced through electronic damping or left and dealt with by best curve fitting or averaging the noise. While it is possible to read the load cell output manually, computerized data collection is recommended highly.

## 8. Analysis and Use of Results

### 8.1 *Criteria:*

8.1.1 The criteria for evaluating the performance of the finishing and furnishing materials of a room can be based both on what occurs within the room and what occurs outside of the room. One key factor affecting occupants outside the room of fire origin is the total energy released. This energy makes the room a heat pump that distributes smoke and hot gases throughout the building. When the room reaches flashover, the possibility of escape for the occupants in an adjacent area is reduced substantially. Considerations within the room may include vertical temperature profiles, smoke and combustion gas species profiles, surface temperatures, heat flux levels developed at the center of the floor, total rate of energy release, and time to flashover.

8.1.2 Consequently, an important criterion is the elapsed time from ignition to flashover in the room. The ignition time could be defined as ignition of either the heat source or the specimen.

8.1.2.1 Flashover has been found to correlate reasonably well with an average air temperature of 500 to 600°C measured

**TABLE 1 Typical Thermal Property Values of Some Common Materials (To be Used for Guidance Only)**

NOTE 1—The data provided in this table (Peacock, et al., NIST, 1994) defines one set of properties for common materials which are not well defined, and are provided for approximate guidance only. The numbers listed within this table cannot be assumed to fully reflect the properties of all materials within the generic class described. Data for common brick and clay brick were provided by the Brick Institute of America.

Materials, in.	Thermal Conductivity, W(m K)	Specific Heat, J/(kg K)	Density, kg/m <sup>3</sup>	Thickness, m	Emissivity, (-)
Gypsum board, ½ in.	0.16	900	790	0.013	0.9
Gypsum board, ⅝ in.	0.16	900	790	0.016	0.9
Gypsum board, ¾ in.	0.16	900	790	0.019	0.9
Gypsum wallboard, ranges	0.16–0.22	900–1047	790–400	0.024–0.050	0.90–0.97
Gypsum board, type X, ⅝ in.	0.14	900	770	0.016	0.9
Gypsum board, type X, ¾ in.	0.22	1085	1680	0.076	0.9
Gypsum substrate, w. glass mat	0.16–0.04	900–720	790–10	0.024–0.050	0.9
Brick, common, 3 in.	0.72	921	1920	0.076	0.9
Clay brick, 3 in.	1.3	1004	2082	0.076	0.9
Fire brick	0.36	750	1040	0.113	0.8
Fire brick composite, range	0.17–0.36	1040	128–750	0.005–0.113	0.95
Concrete, normal weight, 6 in.	1.75	1000	2200	0.15	0.94
Cement mortar, 1 in.	0.72	780	1860	0.025	0.9
Glass plate, ¼ in.	1.4	750	2500	0.006	0.1
Aluminum, pure, ⅝ in.	231	1033	2702	0.003	0.9
Aluminum alloy 2064-T6, ⅝ in.	186	1042	2770	0.003	0.9
Carbon steel, plain, ⅝ in.	48	559	7854	0.003	0.9
Carbon steel, plain, sheet, ¼ in.	48	559	7854	0.0015	0.9
Stainless steel 304, ⅝ in.	19.8	557	7900	0.003	0.9
Plywood building board, ½ in.	0.12	1215	545	0.013	0.9
Hardwood siding, ½ in.	0.094	1170	640	0.013	0.9
Hardboard, high density, ½ in.	0.15	1380	1010	0.013	0.9
Particle board, low density, ½ in.	0.078	1300	590	0.013	0.9
Particle board, high density, ½ in.	0.17	1300	1000	0.013	0.9
Hardwoods (oak, maple), ¾ in.	0.16	1255	720	0.019	0.9
Softwoods (fir, pine), ¾ in.	0.12	1380	510	0.019	0.9
Wood board, shredded, cemented, ½ in.	0.087	1590	350	0.013	0.9
Sheathing, regular density, ½ in.	0.055	1300	290	0.013	0.9
Ceramic (kaolin) fiber insulation	0.22	1047	128	0.116	0.97
Glass fiber insulation, 3-½ in.	0.04	720	105	0.088	0.9
Glass fiber, organic bonded, ½ in.	0.036	795	105	0.013	0.9
Glass fiber, poured or blown, ½ in.	0.043	835	16	0.013	0.9
Glass fiber, coated, duct liner, ½ in.	0.038	835	32	0.013	0.9
Acoustic tile, ½ in.	0.058	1340	290	0.013	0.9
Vermiculite flakes, ½ in.	0.068	835	80	0.006	0.9
Urethane insulation, rigid foam, ½ in.	0.026	1045	70	0.013	0.9

100 mm below the ceiling, or above 600°C measured at the top of the doorway (31). A more direct indication of flashover is provided by the radiant energy flux incident on the floor. A level of 20 kW/m<sup>2</sup> at the center of the floor is indicative of incipient flashover in the room. For some classes of products and certain fire scenarios, flame emergence from the doorway is well correlated to flashover (22). The most convincing indication of flashover can come from the ignition of raw cotton fiber indicators or crumpled newsprint. Consequently, a criterion that may be used in a room fire experiment could be the time to flashover. Flashover can be inferred from measurements made by one or a combination of the following: (1) the thermocouples in the upper part of the room, (2) a total heat flux gage at the center of the floor, (3) the emergence of flames from the doorway (for some products), or (4) by the ignition of cotton indicators or a ball of crumpled newsprint.

8.1.3 If the energy release rate produced during a room fire test is measured using oxygen consumption calorimetry (Ref (38)), criteria can be based on the energy release rates produced by the lining or furnishing materials, or both. Criteria based on energy release rates can be tailored to ensure that only a given fraction of the energy required to produce room flashover is permitted. The following relationship can be used as an

engineering approximation to determine the rate of heat release that will result in room flashover (22).

$$RHR = E \times F \times \dot{V} \quad (2)$$

where:

- RHR = rate of heat release (MW),
- E = energy release per kg of combustion air (E = 3.0 MJ/kg),
- F = fraction of maximum air flow into the room at the onset of flashover (0.3 ≤ F ≤ 0.5),
- V̇ = maximum air flow (kg/s) into the room following flashover,
- V̇ = 0.5 A√H, with A = area of ventilation opening [m<sup>2</sup>], and
- H = height of ventilation opening (m).

This expression permits the calculation of a range of values of rate of heat release sufficient to cause flashover in a room whose floor area does not exceed 500 m<sup>2</sup>.

8.1.4 The potential growth and spread of fire within the room of fire origin is another criterion that is useful for determining the ease with which a major fire may develop. This criterion may be applied by evaluating the size of the igniting

source (whether a wood crib, waste container, or gas burner) necessary to cause flashover or flame emergence from the doorway for a specific test specimen. This requires multiple experiments to determine the size of the ignition source required.

8.1.5 Another criterion that may be applied is based on an evaluation of the fire-damaged area for a fixed size of ignition source (for example, equivalent to a 5-lb (2.3-kg) wood crib) for the experiment specimen. The rate of fire growth can also be documented photographically and used to develop criteria.

8.1.6 Another criterion that might be used is based on the total amount or rate of smoke generated. The rate of smoke generation can be estimated from the optical density per meter (at the top of the doorway) times the volume flow of air from the room. The dilution, coagulation, deposition, and stratification of the smoke make analytical predictions of smoke concentration at remote locations in the building difficult even for a known smoke generation rate.

8.1.7 Optical density correlates well with visibility, and hence it is a good performance criterion. The attenuation level relative to some arbitrary product is certainly a good performance measure. On the other hand, attenuation levels measured in full-scale multi-compartment simulations could be used to establish criteria at locations remote from the room of fire origin.

8.1.8 Other criteria that might be used could be based on the rate of production or the concentration of certain species of gases produced by the burning materials. This information could be used in experiments of smoldering fires to ensure that the concentrations of specific gas species do not exceed tenability limits at critical locations within the room, such as the elevation at which a person sleeping in a chair could be exposed. For non-smoldering fires, the rate of production and concentration of gases could be used to assess the effects on building occupants located outside the room of fire origin. Criteria could be developed by comparison with the production rates of some arbitrary experimental materials. Another criterion could be to ensure that the concentrations of specific gases or total smoke dose at selected locations outside the room of fire origin do not exceed tenability limits. Tenability limits could also be observed for radiant heat (burns) and convected heat stress.

8.1.9 A more challenging approach would be to develop criteria based on the likelihood of the safe evacuation of occupants from the building. The multi-room fire scenario could be used to determine whether the time for detection of the fire and the time for escape to an area of safety are adequate in view of the time for the development of untenable conditions

(presented by high temperatures, poor visibility, or the presence of toxic gases) within the building.

8.1.10 Another criterion that could be useful is based on the potential of post-flashover fire spread from one compartment to another in multi-room scenarios. By measuring the temperature rise on the unexposed sides of the walls of the room of fire origin or measuring heat flux emitted by the unexposed sides of these walls, or both, one can gain a measure of the likelihood of intercompartmental fire spread through the room walls. Should the adjacent rooms be furnished, the same methodology as that outlined in 8.1.2.1 could also be used to determine whether flashover has occurred in rooms adjacent to the room of fire origin.

8.1.11 In summary, the time to flashover of the room, rate of heat release by the room linings and contents, size of the ignition source required to produce flashover of the room, rate and total volume of smoke and combustion gases produced by the fire, and rate of room to room spread of fire, smoke, and other toxic combustion products can all be used to develop criteria that can be useful for evaluating the fire performance in the room experiment arrangement.

8.2 *Analysis*—The analysis of data on the room fire experiments can serve several purposes:

8.2.1 To relate the severity of the room fire experiment to the laboratory-measured fire properties of the materials. This is an attempt to establish empirical relationships that would validate the strengths and weaknesses of the various fire test methods currently in use or proposed for controlling the products to be used in the rooms.

8.2.2 To compare data obtained from room fire experiments to results from room fire models. This comparison indicates the strengths and weaknesses of the models. Studies by Benjamin and Peacock (57, 58) demonstrate the validation of fire models and fire hazard assessment using full-scale tests. Guide E 1355 is a good validation guide for fire models.

8.2.3 To provide input data for room fire models. Paragraph 8.5.10 lists some of the properties that are helpful to modelers. Full-scale data are very important for developing empirical models of fire behavior where a theoretical basis is lacking. These empirical estimates serve further to improve the models.

8.2.4 To evaluate materials and products when estimating their fire performance, particularly those for which no adequate material property tests exist.

## 9. Keywords

9.1 burning characteristics; experiment design; flashover guide; full-scale test; guide; ignition; instrumentation; room fire experiment; ventilation



**REFERENCES**

- (1) *Fire Research 1968*, Report of the Fire Research Steering Committee with the Report of the Director Fire Research, Ministry of Technology, JFRO (Joint Fire Research Organisation), London, United Kingdom, 1969.
- (2) Kawagoe, K., "Fire Behavior in Rooms," Report No. 27, Building Research Institute, Ministry of Construction, Tokyo, Japan, p. 732, 1958.
- (3) Hägglund, B., Jansson, R., and Onnermark, B., "Fire Development in Residential Rooms After Ignition from Nuclear Explosion," FOA Report C20016-D6 (A3), Stockholm, Sweden, 1974.
- (4) Drysdale, D., "An Introduction to Fire Dynamics," Wiley-Interscience Publication, Chichester, United Kingdom, 1985.
- (5) Parker, W. J., Tu, K.-M., Nurbakhsh, S., and Damant, G. H., "Furniture Flammability: An Investigation of the California Technical Bulletin 133 Test, Part III: Full Scale Chair Burns," NISTIR 90-4375, National Institute of Standards and Technology, Gaithersburg, MD, 1990.
- (6) Kokkala, M., Göransson, U., and Šoderbom, J., "Experiments in a Large Room with Combustible Linings," Presented at 2nd International Heat Release and Fire Hazard Symposium, Brussels, Belgium, February 1991.
- (7) Galloway, F. M., and Hirschler, M. M., "The Use of a Model for Hydrogen Chloride Transport and Decay to Predict Airborne Hydrogen Chloride Concentrations in a Full-Scale Room-Corridor Scenario," *Fire Safety Journal*, 19, 1992, pp. 73–101.
- (8) Galloway, F. M., and Hirschler, M. M., "Transport and Decay of Hydrogen Chloride: Use of a Model to Predict Hydrogen Chloride Concentrations in Fires Involving a Room-Corridor-Room Arrangement," *Fire Safety Journal*, Vol 16, 1990, pp. 33–52.
- (9) Gritzo, L. A., and Nicolette, V. F., "Coupled Thermal Response of Objects and Participating Media in Fires and Large Combustion Systems," *Numerical Heat Transfer*, Part A, Vol 28, pp. 531–545, 1995.
- (10) Magnusson, S. F., and Thelanderson, S., "Temperature-Time Curves of Complete Process of Fire Development—Theoretical Study of Wood Fuel Fires in Enclosed Spaces," *Acta Polytechnica Scandinavia*, Civil Engineering and Building Construction Series No. 65, Stockholm, Sweden, 1970.
- (11) Kawagoe, K., and Sekine, T., "Estimation of Fire Temperature-Time Curve in Rooms," Occasional Report No. 11, Building Research Institute, Tokyo, Japan, 1963.
- (12) Odeen, K., "Standard Fire Endurance Tests—Discussion, Criticism, and Alternatives: Fire Test Performance," *ASTM STP 464*, ASTM, Philadelphia, PA, 1979, pp. 30–56.
- (13) Silbulkin, M., "Effects of Material Properties on Burning and Extinction Fires on Vertical Surfaces," Final Report, Brown University, Providence, RI, February 1982.
- (14) Lee, B. T., "Effects of Wall and Room Surfaces on the Rates of Heat, Smoke, and Carbon Monoxide Production in a Park Lodging Bedroom Fire," *NBSIR 85-2998*, National Bureau of Standards, Gaithersburg, MD, February 1985.
- (15) Tran, H. C., and Janssens, M. L., "Room Fire Test for Fire Growth Modeling—A Sensitivity Study," *Journal of Fire Sciences*, Vol 7, July/August 1989, pp. 217–236.
- (16) Peacock, R. D., Jones, W. W., Forney, G. P., Portier, R. W., Reneke, P. A., Bukowski, R. W., and Klote, J. H., "An Update Guide for HAZARD I Version 1.2," *NISTIR 94-5410*, National Institute of Standards and Technology, Gaithersburg, MD, 1994.
- (17) Klitgaard, P. S., and Williamson, R. B., "The Impact of Contents on Building Fires: Journal of Fire and Flammability Consumer Products Flammability Supplement," Vol 2, 1975, pp. 84–113.
- (18) Gross, D., and Fang, J. B., "The Definition of a Low Intensity Fire: Performance Concept in Buildings," *NBS Special Publication 361*, Vol 1, Proceedings of the Joint RILEM-ASTM-CIB Symposium, Philadelphia, PA, May 2–5, 1972.
- (19) Babrauskas, V., Lawson, J. R., Walton, W. D., and Twilley, W. H., "Upholstered Furniture Heat Release Rates Measured with a Furniture Calorimeter," *NBSIR 82-2604*, National Bureau of Standards, Gaithersburg, MD, December 1982.
- (20) Babrauskas, V., "Combustion of Mattresses Exposed to Flaming Ignition Sources, Part II: Bench-Scale Tests and Recommended Standard Test," *NBSIR 80-2186*, National Bureau of Standards, Gaithersburg, MD, February 1981.
- (21) Gross, D., "Data Sources for Parameters used in Predictive Modeling of Fire Growth and Smoke Spread," *NBSIR 85-3223*, National Bureau of Standards, Gaithersburg, MD, 1985.
- (22) Babrauskas, V., and Krasny, J., "Fire Behavior of Upholstered Furniture," *NBS Monograph 173*, National Bureau of Standards, Gaithersburg, MD, 1985.
- (23) Holmlund, C., "Burning of Small Crib Ignition Sources," *Report No. 569*, Technical Research Center of Finland, Espoo, Finland, November 1988.
- (24) Ahonen, A., Kokkala, M., and Weckman, H., "Burning Characteristics of Potential Ignition Sources of Room Fires," Research Report 285, Technical Research Centre of Finland, Espoo, Finland, June 1984.
- (25) Castino, G. T., Beyreis, J. R., and Metes, W. S., "Flammability Studies of Cellular Plastics and Other Building Materials Used for Interior Finish," Underwriters' Laboratories, Inc., Northbrook, IL, 1975.
- (26) Quintiere, J. G., and McCaffrey, B. J., "The Burning of Wood and Plastic Cribs in an Enclosure: Volume 1," *NBSIR 80-2054*, National Bureau of Standards, Gaithersburg, MD, 1980.
- (27) Babrauskas, V., "Flame Lengths Under Ceiling," *Fire and Materials*, Vol 4, 1980, pp. 119–126.
- (28) Thomas, P., and Karlsson, B., "On The Length of Flames Under Ceiling," Report LUTVDCT/TVBB-3059, Lund Institute of Technology, Dept. of Fire Safety Engineering, Lund, Sweden, 1990.
- (29) Lie, T. T., *Fire and Buildings*, Applied Science Publishers, Ltd., London, United Kingdom, 1972.
- (30) Thomas, P. H., "The Size of Flames from Natural Fires," *Ninth Symposium on Combustion*, Academic Press, New York and London, United Kingdom, 1963, pp. 844–859.
- (31) Tarifa, C. S., Del Notario, P. P., and Valdes, E. C. F., "Open Fires," Instituto Nacional de Tecnica Aeroespacial' Esteban Terrada', Madrid, Spain, 1967, p. 86.
- (32) Yokoi, S., "Study on the Prevention of Fire Spread Caused by Hot Upward Current," Report No. 34, Building Research Institute, Ministry of Construction, Tokyo, Japan, 1969, pp. 34–36.
- (33) Yokoi, S., "On the Heights of Flames from Burning Cribs," Occasional Report No. 12, Building Research Institute, Ministry of Construction, Tokyo, Japan, 1963, p. 12.
- (34) Alpert, R. L., "Fire Induced Turbulent Ceiling Jet," Technical Report 19722-2, Factory Mutual Research Corporation, May 1971.
- (35) Alpert, R. L., "Calculation of Response Time of Ceiling-Mounted Fire Detectors," *Fire Technology*, Vol 8, 1972.
- (36) Steckler, K., Tu, K. M., and Twilley, W., "Calibration Technique for Heat Flux Sensors Used in Fire Experiments and Standard Fire Tests," Report to Federal Aviation Administration, National Institute of Standards and Technology, Gaithersburg, MD, 1989.
- (37) Olsson, S., "Calibration of Radiant Heat Flux Meters: The Development of a Water Cooled Aperture for Use with Black Body Cavities," *Nordtest Project 873-90*, SP Report 1991:58, Swedish National Testing and Research Institute, Boras, Sweden.
- (38) Janssens, M., "Measuring Rate of Heat Release In Full-Scale Fire Tests By Oxygen Consumption," *Fire Technology*, Vol 27, August 1991, pp. 237–249.
- (39) Babrauskas, V., and Grayson, S. J., "Heat Release in Fires," *Elsevier*, London, UK, 1992.

 **E 603 – 01**

- (40) Gardon, R., “An Instrument for the Direct Measurement of Intense Thermal Radiation,” *Review of Scientific Instruments*, Vol 24, No. 5, May 1953, pp. 366–370.
- (41) Borell, G. J., and Diller, T. E., “Convection Calibration Method for Local Heat Flux Gages,” *Journal of Heat Transfer*, Vol 109, February 1987, pp. 83–89.
- (42) Keltner, N. R., and Wildin, M. W., “Transient Response of Circular Foil Heat-Flux Gages to Radiative Fluxes,” *The Review of Scientific Instruments*, Vol 46, No. 9, September 1975.
- (43) Benedict, R. P., *Fundamentals of Temperature, Pressure and Air Flow Measurement*, 3rd ed., Omega Press.
- (44) Ower, E., and Pankhurst, R. C., *The Measurement of Air Flow*, Pergamon Press, 5th ed., 1977, pp. 112–147.
- (45) Peacock, R. D., and Babrauskas, V., “Analysis of Large-Scale Fire Test Data,” *Fire Safety Journal*, Vol 17, 1991, pp. 387–414.
- (46) Bukowski, R. W., “Smoke Measurements in Large- and Small-Scale Fire Testing,” *Fire Technology*, Part I, Vol 15, No. 3, 1979, pp. 173–179; Part II, Vol 15, No. 4, 1979, pp. 271–281.
- (47) Mulholland, G., “How Well are we Measuring Smoke?” *Fire and Materials*, Vol 6, 1982, pp. 65–67.
- (48) Beitel, J. J., Bertelo, C. A., Carroll, W. F., Gardner, R. A., Grand, A. F., Hirschler, M. M., and Smith, G. F., “Hydrogen Chloride Transport and Decay in a Large Apparatus. I. Decomposition of Poly(Vinyl Chloride) Wire Insulation in a Plenum by Current Overload,” *J. Fire Sciences*, 4, 1986, pp. 15–41.
- (49) Galloway, F. M., Hirschler, M. M., and Smith, G. F., “Small Scale Experiments for Measuring HCl Decay in Fire Atmospheres,” in *Proc. Interflam '90*, Ed. C. A. Franks, Sept. 3–6, 1990, Canterbury, UK, *Interscience*, London, UK, 1990, pp. 127–143.
- (50) Kaplan, H. L., Grand, A. F., and Hartzell, G. E., “Combustion Toxicology—Principles and Test Methods,” Technomic, Lancaster, PA, 1983.
- (51) Purser, D., “Toxicity Assessment of Combustion Products,” *SFPE Handbook of Fire Protection Engineering*, National Fire Protection Association, Quincy, MA, Section 1, Chapter 14, 1988.
- (52) Hirschler, M. M., “Smoke Toxicity Measurements Made so that the Results can be Used for Improved Fire Safety,” *Journal of Fire Sciences*, Vol 9, 1991, pp. 330–347.
- (53) Babrauskas, V., Harris, R. H., Braun, E., Levin, B. C., Paabo, M., and Gann, R. G., “The Role of Bench-Scale Data in Assessing Real-Scale Fire Toxicity,” NIST Technical Note No. 1284, National Institute of Standards and Technology, Gaithersburg, MD, 1991.
- (54) Babrauskas, V., Levin, B. C., Gann, R. G., Paabo, M., Harris, R. H., Peacock, R. D., and Yusa, S., “Toxic Potency Measurement for Fire Hazard Analysis,” NIST Special Publication No. 827, National Institute of Standards and Technology, Gaithersburg, MD, 1991.
- (55) Beitel, J. J., Bertelo, C. A., Carroll, W. A., Grand, A. F., Hirschler, M. M., and Smith, G. F., “Hydrogen Chloride Transport and Decay in a Large Apparatus, II: Variables Affecting Hydrogen Chloride Decay,” *Journal of Fire Sciences*, Vol 5, 1987, pp. 105–145.
- (56) Galloway, F. M., and Hirschler, M. M., “A Model for the Spontaneous Removal of Airborne Hydrogen Chloride by Common Surfaces,” *Fire Safety Journal*, Vol 14, 1989, pp. 251–268.
- (57) Benjamin, I. A., “Toxic Hazard Analysis: Electrical Non-Metallic Tubing,” *Journal of Fire Sciences*, Vol 5, January/February 1987, pp. 25–48.
- (58) Peacock, R. D., Davis, S., and Lee, B. T., “An Experimental Data Set for the Accuracy Assessment of Room Fire Models,” *NBSIR 88-3752*, National Bureau of Standards, Gaithersburg, MD, 1988.

*ASTM International takes no position respecting the validity of any patent rights asserted in connection with any item mentioned in this standard. Users of this standard are expressly advised that determination of the validity of any such patent rights, and the risk of infringement of such rights, are entirely their own responsibility.*

*This standard is subject to revision at any time by the responsible technical committee and must be reviewed every five years and if not revised, either reapproved or withdrawn. Your comments are invited either for revision of this standard or for additional standards and should be addressed to ASTM International Headquarters. Your comments will receive careful consideration at a meeting of the responsible technical committee, which you may attend. If you feel that your comments have not received a fair hearing you should make your views known to the ASTM Committee on Standards, at the address shown below.*

*This standard is copyrighted by ASTM International, 100 Barr Harbor Drive, PO Box C700, West Conshohocken, PA 19428-2959, United States. Individual reprints (single or multiple copies) of this standard may be obtained by contacting ASTM at the above address or at 610-832-9585 (phone), 610-832-9555 (fax), or service@astm.org (e-mail); or through the ASTM website (www.astm.org).*