



Standard Test Method for Heat and Visible Smoke Release Rates for Materials and Products¹

This standard is issued under the fixed designation E 906; the number immediately following the designation indicates the year of original adoption or, in the case of revision, the year of last revision. A number in parentheses indicates the year of last reapproval. A superscript epsilon (ϵ) indicates an editorial change since the last revision or reapproval.

1. Scope

1.1 This test method provides for determining the release rates of heat and visible smoke (Note 1) from materials, products, or assemblies when exposed to different levels of radiant heat.

NOTE 1—Visible smoke is described in terms of the obscuration of transmitted light caused by combustion products released during the tests (see 14.2.1).

1.2 This fire-test-response method assesses heat release by a thermal method, thermopile, using a radiant heat source composed of an array of four electrical resistance elements.

1.3 This test method provides for radiant thermal exposure of a specimen both with and without a pilot. Piloted ignition results from direct flame impingement on the specimen (piloted, point ignition) or from use of the pilot to ignite gases evolved by pyrolysis of the specimen.

1.4 Heat and smoke release are measured from the moment the specimen is injected into a controlled exposure chamber. The measurements are continued during the period of ignition (and progressive flame involvement of the surface in the case of point ignition), and to such a time that the test is terminated.

1.5 This test method is suitable for exposing essentially planar materials, products or assemblies to a constant, imposed external heat flux that ranges from 0 to 80 kW/m².

1.6 This test method is intended for use in research and development and not as a basis for rating, regulatory, or code purposes.

1.7 The apparatus described in this test method has been used in two configurations. Configuration A is that which is used by the Federal Aviation Administration for assessing materials for aircraft use, at an external heat flux of 35 kW/m² (DOT/FAA/CT-89/15), while configuration B is suitable, at various incident heat fluxes, for research and development purposes.

¹ This test method is under the jurisdiction of ASTM Committee E-5 on Fire Standards and is the direct responsibility of Subcommittee E05.21 on Smoke and Combustion Products.

Current edition approved Feb. 10, 1999. Published July 1999. Originally published E 906-83. Last previous edition E 906 – 98a.

1.8 This test method does not provide information on the fire performance of the test specimens under fire conditions other than those conditions specified in this test method. Known limitations of this test method are described in 1.8.1-1.8.5.

1.8.1 Heat and smoke release rates depend on a number of factors, including the formation of surface char, the formation of an adherent ash, sample thickness, and the method of mounting.

1.8.2 Heat release values are a function of the specific specimen size (exposed area) tested. Results are not directly scaleable to different exposed surface areas for some products.

1.8.3 The test method is limited to the specified specimen sizes of materials, products, or assemblies. If products are to be tested, the test specimen shall be representative of the product in actual use. The test is limited to exposure of one surface; the options for exposed surface are vertical and horizontal facing up.

1.8.4 At very high specimen heat release rates, it is possible that flaming is observed above the stack, which makes the test invalid.

1.8.5 No general relationship has been established between heat release rate values obtained from horizontally and vertically oriented specimens. Specimens that melt and drip in the vertical orientation shall be tested horizontally.

1.9 Use the SI system of units in referee decisions; see IEEE/ASTM SI-10.

1.10 Fire testing of products and materials is inherently hazardous, and adequate safeguards for personnel and property shall be employed in conducting these tests. Fire testing involves hazardous materials, operations, and equipment. See Section 6.

1.11 *This standard is used to measure and describe the response of materials, products, or assemblies to heat and flame under controlled conditions, but does not by itself incorporate all factors required for fire hazard or fire risk assessment of the materials, products, or assemblies under actual fire conditions.*

1.12 This standard does not purport to address all of the safety concerns, if any, associated with its use. It is the responsibility of the user of this standard to establish appropriate safety and health practices and determine the applicability of regulatory limitations prior to use.

2. Referenced Documents

2.1 ASTM Standards:

D 618 Practice for Conditioning Plastics for Testing²

E 176 Terminology of Fire Standards³

E 380 Practice for Use of the International System of Units (SI) (the Modernized Metric System)³

E 1354 Test Method for Heat and Visible Smoke Release Rates for Materials and Products Using an Oxygen Consumption Calorimeter³

2.2 ISO Standard:

ISO/IEC Guide 52 - Glossary of Fire Terms and Definitions⁴

2.3 Federal Aviation Administration Standard:

Aircraft Material Fire Test Handbook, DOT/FAA/CT-89/15, FAA Technical Center, September 1990⁵

3. Terminology

3.1 *Definitions*—For definitions of terms used in this test method refer to the terminology contained in Terminology E 176 and ISO/IEC Guide 52. In case of conflict, the definitions given in Terminology E 176 shall prevail.

3.2 Definitions of Terms Specific to This Standard:

3.2.1 *continuous, as related to data acquisition, adj*—conducted at data collection intervals of 5 s or less.

3.2.2 *exposed surface, n*—that surface of the specimen subjected to the incident heat.

3.2.3 *flashing, n*—existence of flame on or over the surface of the specimen for periods of less than 4 s.

3.2.4 *gas phase ignition, n*—ignition of pyrolysis products leaving a heated surface by a pilot flame or other ignition source that does not impinge on, nor significantly affect, for example, by reradiation, the heated surface.

3.2.5 *orientation, n*—plane in which the exposed face of the specimen is located during testing, either vertical or horizontally face upwards.

3.2.6 *SMOKE unit*—the concentration of smoke particulates in a cubic metre of air that reduces the percent transmission of light through a 1-m path to 10 %. SMOKE = Standard Metric Optical Kinetic Emission.

3.2.7 *sustained flaming, n*—the existence of flame on or over the majority of the surface of the specimen for a period of 4 s or more.

3.2.8 *time to ignition, n*—time between the start of the test and the presence of a flame on or over most of the specimen surface for a period of at least 4 s.

3.2.9 *time to sustained flaming, n*—time to ignition.

4. Summary of Test Method

4.1 The specimen to be tested is injected into an environmental chamber through which a constant flow of air passes. The specimen's exposure is determined by a radiant heat source adjusted to produce the desired total heat flux on the specimen. Exposure options include: horizontal or vertical orientations; nonpiloted ignition, piloted ignition of evolved gases, or point ignition of the surface. The changes in temperature and optical density of the gas leaving the chamber are monitored, and from this data the release rates of heat and visible smoke (see 14.2.1) are calculated.

5. Significance and Use

5.1 This test method provides a description of the behavior of material specimens under a specified fire exposure in terms of the release rate of heat and visible smoke. It is possible to determine the change in behavior of materials and products with change in heat-flux exposure by testing specimens in a series of exposures that cover a range of heat fluxes.

5.2 The data obtained for a specific test describe the rate of heat and smoke release of the specimen when exposed to the specific environmental conditions and procedures used in performing that test.

5.3 The entire exposed surface of the specimen will not be burning during the progressive involvement phase when piloted, point ignition (impingement) procedures are used. During the period of progressive surface involvement, release rates of heat and smoke are “per square metre of original exposed surface area” not “per square metre of flame involved surface.”

5.4 The rates of both heat and smoke release are calculated per square metre of original surface area exposed. If a specimen swells, sags, delaminates, or otherwise deforms so that the exposed surface area changes, calculated release rates correspond to the original area, not to the new surface area.

5.5 Heat-release values depend on mode of ignition. Gas phase ignition gives a more dimensionally consistent measure of release rate when very rapid or immediate flame involvement of the specimen surface occurs. However, piloted, point ignition allows release-rate information to be obtained at external heat flux from zero up to that required for satisfactory gas-phase ignition, usually over 20 kW/m² external exposure. No correlation between the two modes of piloted ignition has been established.

5.6 Release rates depend on many factors, some of which cannot be controlled. It is possible that samples that produce a surface char, a layer of adherent ash, or those that are composites or laminates do not attain a steady-state release rate. Thermally thin specimens, that is, specimens whose unexposed surface changes temperature during period of test, will not attain a steady-state release rate. Therefore, release rates for a given material will depend, for example, on how the material is used, its thickness, and the method of mounting.

5.7 Heat-release values are for the specific specimen size (exposed area) tested. Results are not directly scalable to different exposed surface areas for some products.

5.8 The method is limited to specimen sizes of materials in accordance with 7.1 and to products from which it is possible to obtain a test specimen representative of the product in actual

² Annual Book of ASTM Standards, Vol 08.01.

³ Annual Book of ASTM Standards, Vol 04.07.

⁴ Available from International Standardization Organization, P.O. Box 56, CH-1211, Geneva 20, Switzerland.

⁵ Available from National Technical Information Service, Springfield, VA 22161.

use. The test is limited to exposure of one surface; there are two options for exposure orientation: either vertical or horizontal. If a heat release rate of 8 kW, which is equivalent to 355 kW/m² for 150 by 150-mm vertical specimens, or 533 kW/m² for 100 by 150-mm horizontal specimens is exceeded, there is danger of combustion occurring above the stack.

5.9 No general relationship between release rate values obtained from horizontally and vertically oriented specimens has been established. Conduct tests on specimens in the form in which the material is oriented in end use conditions. To provide additional information, conduct tests in the horizontal orientation for those specimens that melt and drip in the vertical orientation.

5.10 Release rate measurements provide useful information for product development by giving a quantitative measure of specific changes in fire test performance caused by product modifications.

5.11 This test method differs in both the method of exposure and the calculation procedure from the techniques used in Test Method E 1354, the cone calorimeter, which assesses heat release by oxygen consumption calorimetry, using a truncated cone as a radiant source.

6. Operator Safety

6.1 The test procedure involves high temperatures, and combustion processes. Therefore, it is possible for eye injuries, burns, ignition of extraneous objects or clothing, and inhalation of smoke or combustion products to occur, unless proper precautions are taken. To avoid accidental leakage of toxic combustion products into the surrounding atmosphere, it is advisable to evacuate the chamber, at the end of a test, into an exhaust system with adequate capacity. The operator must use heavy gloves, safety tongs or other suitable protection for removal of the specimen holder. The venting must be checked periodically for proper operation. Care shall be taken not to touch the spark igniter during operation, if used, since it carries a substantial potential. The exhaust system of the apparatus shall be checked for proper operation before testing and shall discharge into a building exhaust system with adequate capacity. The possibility of the violent ejection of molten hot material or sharp fragments from some kinds of specimens when irradiated must be taken into account.

7. Sample Preparation

7.1 The standard size for vertically mounted specimens is 150 ± 2 mm by 150 ± 2 mm (6.0 ± 0.06 in. by 6.0 ± 0.06 in.) exposed surface with thickness up to 100 mm (4.0 in.). The standard size for horizontally mounted specimens is 100 ± 2 mm by 150 ± 2 mm (6.0 ± 0.06 in. by 6.0 ± 0.06 in.) exposed surface, up to 45 mm (1.75 in.) thick. Mount thin specimens, such as wall or floor coverings, in the same manner as used. For example, test a wall covering to be glued to gypsum wall board when glued to a section of gypsum board using the same type of adhesive. The assembly shall be considered the specimen to be tested. Applications requiring thicknesses greater than 45 mm (1.75 in.) shall be tested at 45 mm (1.75 in.) thicknesses.

7.2 *Conditioning*—Condition the specimens at 23 ± 3°C (70 ± 5°F) and 50 ± 5 % relative humidity for a minimum of 24 h prior to test, or as described by Procedure A of Practice D 618, if appropriate.

7.3 *Mounting*—Expose only one surface of a specimen during a test. Insulate, on five sides, specimens that have a slab geometry. A single layer of 0.025-mm (0.001 in.) aluminum foil shall be wrapped tightly on all unexposed sides with the dull side of the foil facing the specimen surface. For products whose exposed surface is not a plane, describe mounting and method of calculating surface area exposed when reporting results.

7.4 *Specimen Orientation*—For specimens with anisotropic properties (meaning they have different properties in different directions such as machine and cross-machine directions for extrusions, wrap and fill for woven fabrics), the specimens shall be tested in the orientation giving the highest results. If this orientation is not known prior to test, two sets of at least three specimens each shall be prepared and tested, with one set oriented in one direction and the second set oriented in the other direction.

8. Release Rate Apparatus—Configuration A

8.1 The apparatus shown in Figs. 1 and 2 shall be used to determine heat release rates. All exterior surfaces of the apparatus, except the holding chamber, shall be insulated with 25 ± 1 mm (1 ± 0.04 in.) thick, low-density, high-temperature, fiberglass board insulation.^{6,7} A gasketed door, through which the sample injection rod slides, shall be provided to form an airtight closure on the specimen hold chamber.

8.2 *Thermopile*—The temperature difference between the air entering the environmental chamber and that leaving shall be monitored by a thermopile having 5 hot and 5 cold 24-gage chromel-alumel junctions. The loop to be formed by the thermocouple junction shall be 1.3 ± 0.3 mm (0.050 ± 0.010 in.) in diameter. The cold junctions shall be located in the pan below the air distribution plate (see 8.4). The hot junctions shall be located 10 ± 1 mm (0.38 ± 0.04 in.) below the top of the chimney. One of the hot junctions shall be placed at the center of the chimney's cross section, and the other four shall be placed on the chimney diagonals 30 ± 1 mm (1.18 ± 0.04 in.) from the center thermocouple.

8.3 *Radiant Heat Source*—A radiant heat source for generating a heating flux of up to 80 kW/m², using four silicon carbide elements Type LL, 508 ± 3 mm (20 ± 1 in.) by 16 ± 1 mm (0.63 ± 0.04 in.), with a nominal resistance of 1.4 Ω, as shown in Figs. 1-3, shall be used. The silicon carbide elements shall be mounted in the stainless steel panel box by inserting them through 16 ± 1 mm (0.63 ± 0.04 in.) holes in 0.9 ± 0.1-mm (0.03 ± 0.004-in.) thick ceramic fiber or calcium-silicate millboard. Locations of the holes in the pads and

⁶ Owens-Corning Flat Duct Board, Type 475-FR, density 65 kg/m³ (4 lb/ft³), thermal conductivity 0.033 W/(m²K) (10 Btu/(ft² min)), 25 mm (1 in.) thick, or its equivalent.

⁷ The sole source of supply of the apparatus known to the committee at this time is Owens-Corning, Granville, OH. If you are aware of alternative suppliers, please provide this information to ASTM Headquarters. Your comments will receive careful consideration at a meeting of the responsible technical committee,¹ which you may attend.

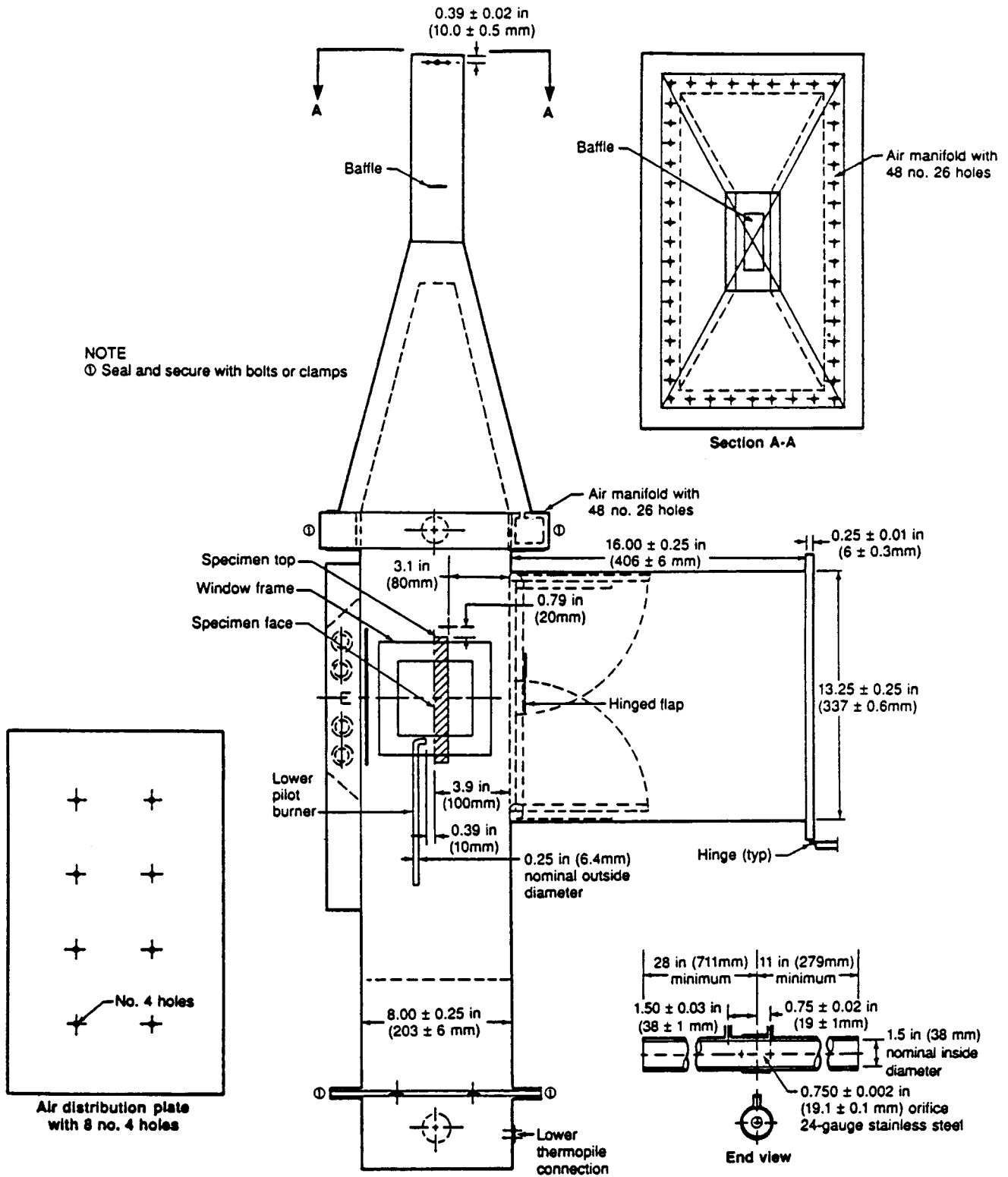

FIG. 1 Rate of Heat Release Apparatus—Example 1

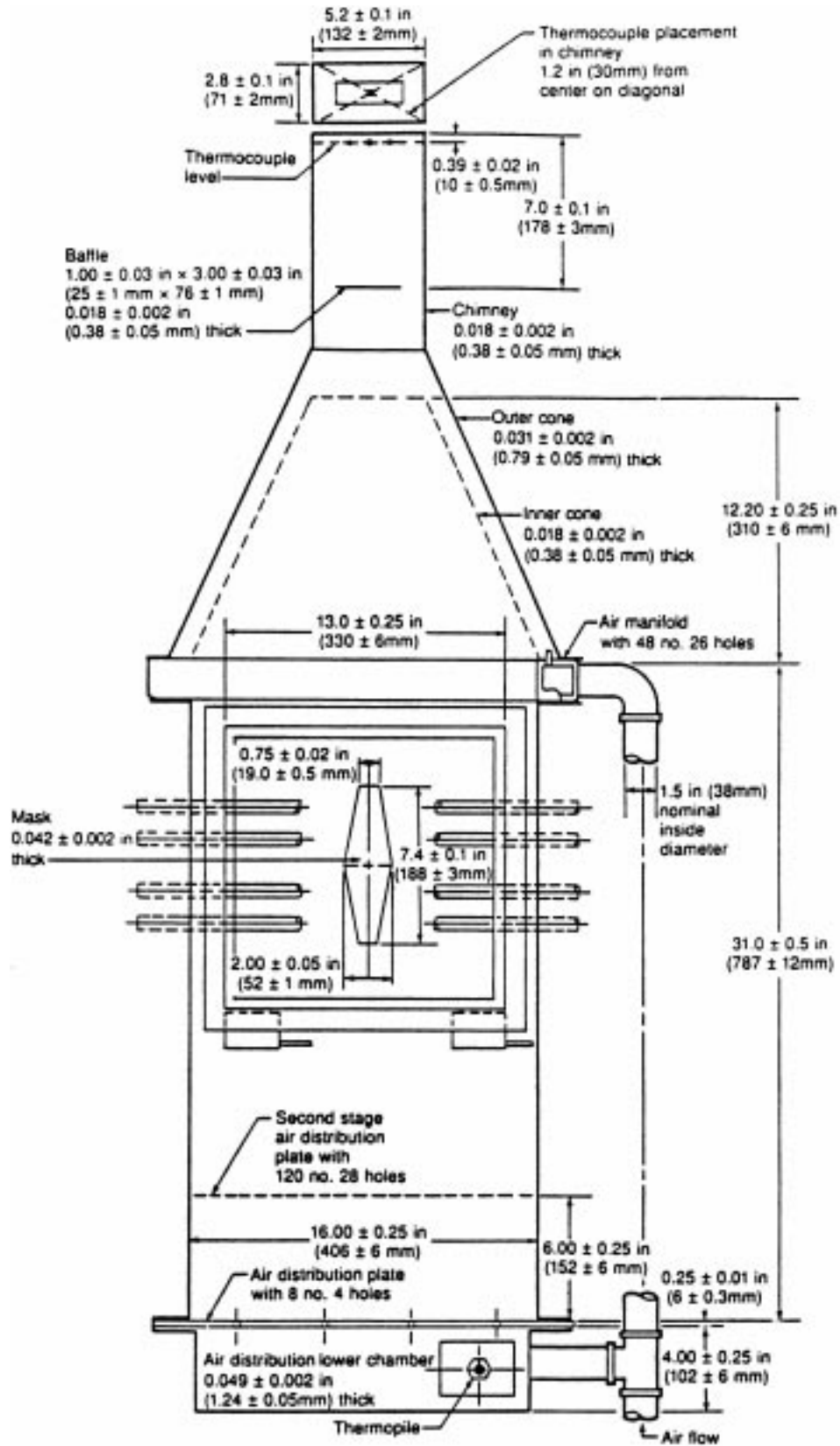

FIG. 2 Rate of Heat Release Apparatus—Example 2

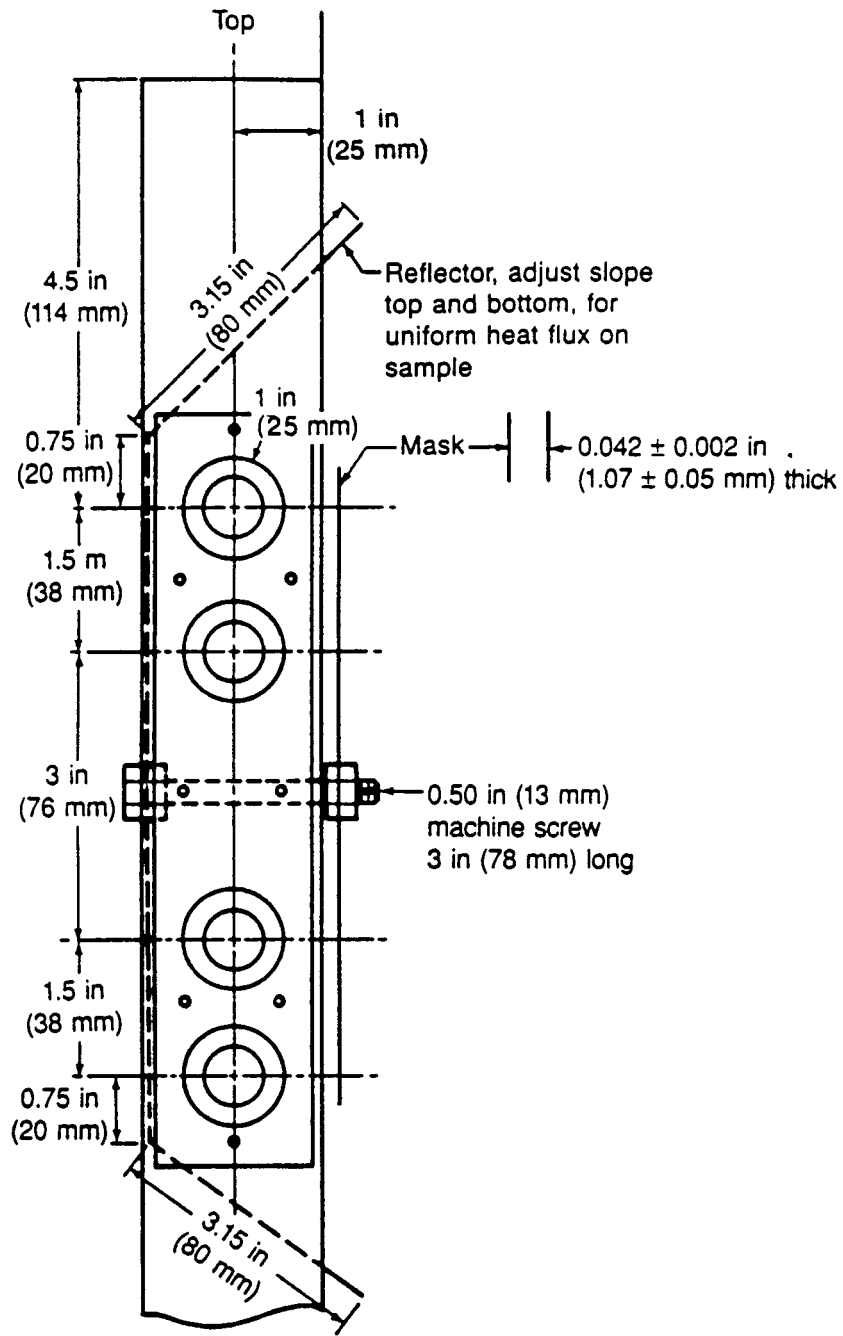

FIG. 3 Side View—Globar Radiant Heat Panel

stainless steel covered plates shall be as shown in Fig. 3. A truncated diamond-shaped mask constructed of 1.07 ± 0.05 mm (0.042 ± 0.002 in.) stainless steel shall be added to provide uniform heat flux density over the area occupied by the vertical specimen. An adjustable power supply capable of producing 12.5 kVA shall be provided. The heat flux density over the specimen surface when set at 35 kW/m^2 shall be uniform within 5 %, and shall be checked periodically and after each heating element change. Uniformity of heat flux density shall be determined by calorimeter measurements at the center and at the four corners of the specimen surface.

8.4 Air Distribution System. The air entering the apparatus shall be 21 to $24 \text{ }^\circ\text{C}$ (70 – $75 \text{ }^\circ\text{F}$) in temperature and set at approximately $0.04 \pm 0.01 \text{ m}^3/\text{s}$ ($85 \pm 20 \text{ ft}^3/\text{min}$) using an orifice meter. The orifice meter shall be comprised of a square-edged circular plate orifice, 0.5 ± 0.1 mm (0.020 ± 0.004 in.) thick, located in a circular pipe with a diameter of 38 ± 1 mm (1.50 ± 0.04 in.), with two pressure measuring points located 38 ± 1 mm (1.50 ± 0.04 in.) above and 20 ± 1 mm (0.75 ± 0.04 in.) below the orifice and connected to a mercury manometer. The inlet pipe shall remain 38 ± 1 mm (1.50 ± 0.04 in.) in diameter (Fig. 1).

8.4.1 The air entering the environmental chamber shall be distributed by a 63 ± 2 mm (0.25 ± 0.04 in.) thick aluminum plate having eight No. 4 drill holes, 51 ± 1 mm (2.0 ± 0.04 in.) from the sides on 102 ± 2 mm (4 ± 0.08 in.) centers, mounted at the base of the environmental chamber. A second plate having 120 evenly spaced, No. 28 drill holes shall be mounted 152 ± 2 mm (6 ± 0.08 in.) above the aluminum plate (Fig. 2).

8.4.2 The air supply manifold at the base of the pyramidal section shall have 48 evenly spaced, No. 26 drill holes 10 ± 1 mm (0.38 ± 0.04 in.) from the inner edge of the manifold, resulting in an airflow split of approximately three to one within the apparatus (Fig. 1).

8.5 Exhaust Stack. An exhaust stack, 133 ± 1 mm by 70 ± 1 mm (5.25 ± 0.04 in. by 2.75 ± 0.04 in.) in cross section, and 254 ± 1 mm (10 ± 0.04 in.) long, fabricated from stainless steel, shall be mounted on the outlet of the pyramidal section (see Figs. 1 and 2). A 25 ± 1 mm by 76 ± 1 mm (1 ± 0.04 by 3 ± 0.04 in.) plate of 0.50 ± 0.05 mm (0.018 ± 0.002 in) stainless steel shall be centered inside the stack, perpendicular to the airflow, 76 ± 1 mm (3 ± 0.04 in.) above the base of the stack.

8.6 Specimen Holders Specimen holders shall be fabricated of stainless steel sheet 0.43 ± 0.05 mm (0.017 ± 0.002 in.) thick as shown in Fig. 4. Specimen holders shall be attached to the injection rod using the support shown in Fig. 4. Each holder shall be provided with a “V”-shaped spring pressure plate. The position of the spring pressure plate shall be capable of being changed to accommodate different specimen thicknesses by inserting the retaining rod in different holes of the specimen holder frame. Each holder shall also have two wires attached to the front of the holder to secure the face of the specimen in the holder.

8.6.1 Drip Pan A drip pan shall be fabricated of stainless steel sheet 0.43 ± 0.05 mm (0.017 ± 0.002 in.) thick as shown in Fig. 4 and be attached to the specimen holder using the

flanges shown in Fig. 4. Line the drip pan with aluminum foil, to facilitate cleaning after a test.

NOTE 2—Drip pans are required to prevent melting specimens from dripping into the lower pilot burner.

8.7 Calorimeter—A water-cooled, total heat flux density, foil-type Gardon gage calorimeter shall be used to measure the total heat flux density at a point where the center of the specimen surface is located at the start of the test. When positioned to measure flux density, the sensing surface of the meter shall be flush with the supporting device surface so that air heated by such a support does not contact the sensing surface of the meter.

8.8 Pilot Burners—Pilot burners shall be placed at the bottom and top of the specimens. The burners shall be constructed of stainless steel tubing with a 6 ± 1 mm (0.25 ± 0.04 in.) outside diameter (OD) and 0.8 ± 0.1 mm (0.03 ± 0.004 in.) wall thickness.

8.8.1 Lower Pilot Burner—The lower pilot burner shall be located as shown in Fig. 1. The lower pilot burner shall have its centerline perpendicular to the surface of the specimen and 5 ± 1 mm (0.19 ± 0.04 in.) above the specimen’s lower exposed edge, and shall have its end 10 ± 1 mm (0.38 ± 0.04 in.) from the specimen’s surface. A methane-air mixture shall be used consisting of $120 \pm 10 \text{ cm}^3/\text{min}$ ($0.0040 \pm 0.0003 \text{ ft}^3/\text{min}$) (at standard temperature and pressure) methane (99 % minimum purity) and an air supply, adjusted to produce a flame such that the inner cone is approximately the same length as the diameter of the flame.

8.8.2 Spark Igniter—A spark igniter shall be installed to ensure that the lower pilot burner remains burning. A test is invalidated if the lower pilot burner becomes extinguished for any period that exceeds 3 s. A circuit for a satisfactory device is sketched in Fig. 5.

8.8.3 Upper Pilot Burner—An upper pilot burner shall be provided to produce flamelets above the test specimen to ignite flammable gases. If any of the flamelets on the upper pilot burner extinguishes for a period longer than 3 s during the test, the test is invalidated. The upper pilot burner shall be constructed from a piece of stainless steel tubing with an OD of 6 ± 1 mm (0.25 ± 0.04 in.) and a wall thickness of 0.8 ± 0.1 mm (0.03 ± 0.004 in.). The diameter hole drilled 10 ± 1 mm (0.38 ± 0.04 in.) above the upper edge of the window frame, and be supported and positioned by an adjustable Z-shaped bracket mounted outside the environmental chamber above the viewing window. The tubing shall be located 19 ± 1 mm (0.75 ± 0.04 in.) above and 19 ± 1 mm (0.75 ± 0.04 in.) behind the upper front edge of the specimen holder, and installed such that the holes are directed horizontally toward the radiant heat source. One end of the tubing shall be closed with a silver solder plug or equivalent.

8.8.4 Standard Three-Hole Burner—The standard three-hole upper pilot burner shall be constructed from a piece of 6 ± 1 mm (0.25 ± 0.04 in.) OD tubing 360 ± 10 mm (14 ± 0.4 in.) long. Three No. 40 (2.5 ± 0.1 mm (0.098 ± 0.004 in.) diameter) drill holes, each radiating in the same direction, shall be drilled into the tubing. The holes shall be spaced 60 ± 1 mm (2.4 ± 0.04 in.) apart, with the first hole located 5 ± 1 mm (0.19 ± 0.04 in.) from the closed end, as is shown in Fig. 6.

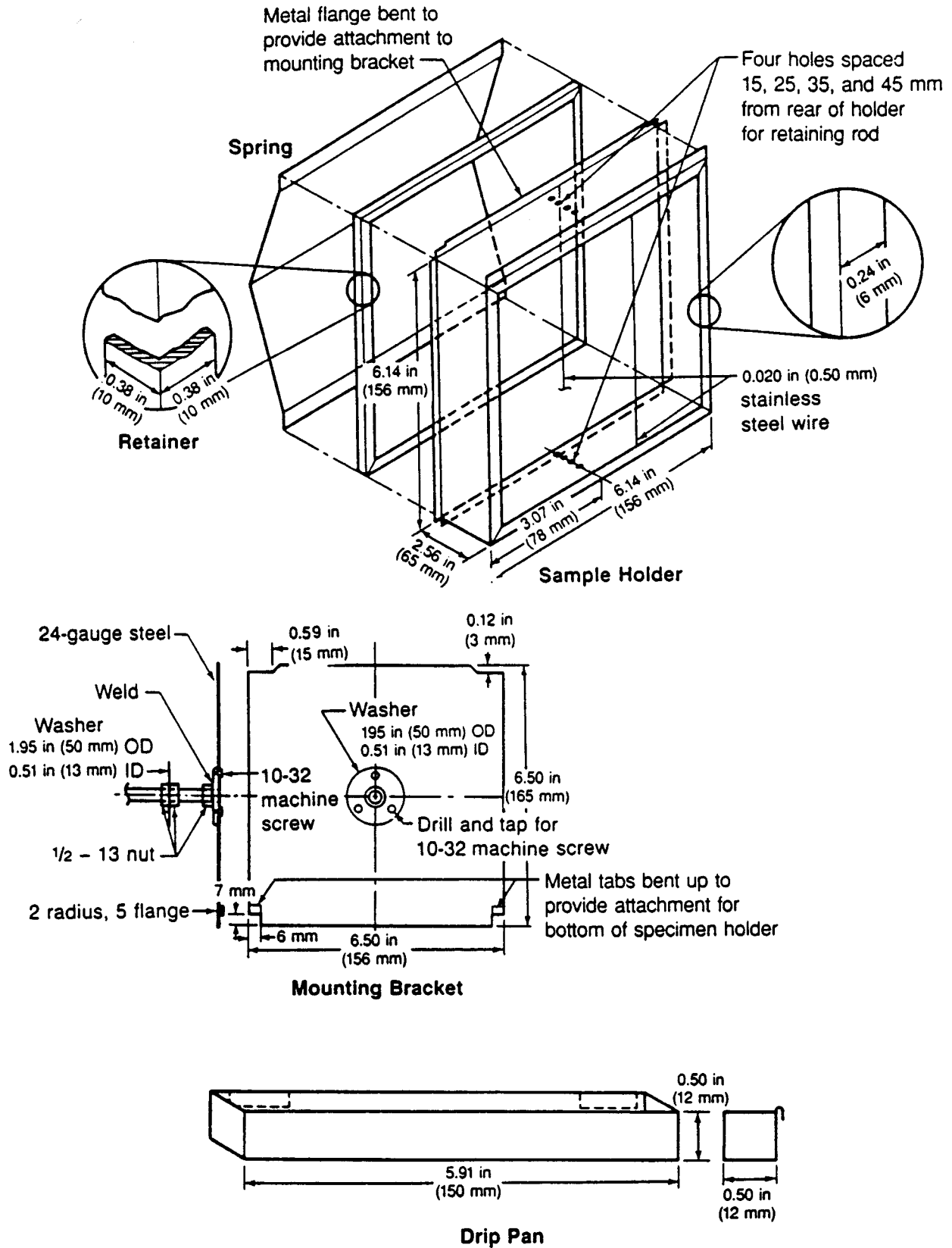

FIG. 4 Heat Release Specimen Holder, Mounting Bracket, and Drip Pan

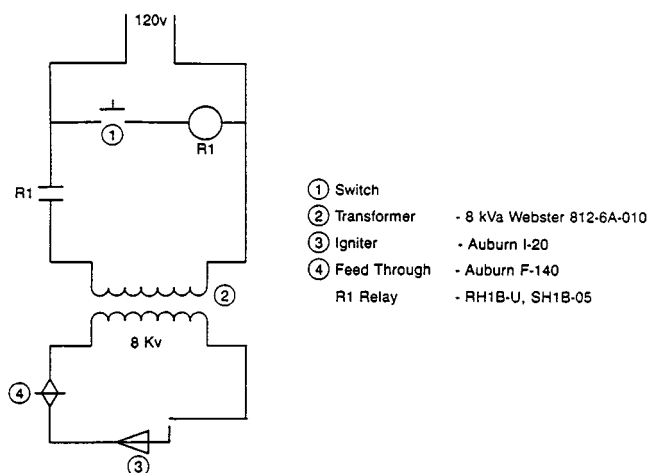

FIG. 5 Lower Pilot Burner Igniter Schematic

The burner shall be positioned above the specimen holder so that the middle hole lies in the plane perpendicular to the exposed surface of the specimen and passes through its vertical centerline. The burner fuel shall be methane of 99 % minimum purity. The fuel flow rate shall be adjusted to produce flamelets 25 mm (1 in.) in length that bend upwards slightly above the burner tube.

8.8.5 *Optional Fourteen-Hole Burner*—An optional burner that has been found satisfactory is as follows; this burner has a greater probability of reigniting flamelets which become extinguished during a test. Fourteen No. 59 drill holes, each radiating in the same direction, shall be drilled into a 400 ± 10 mm (15.8 ± 0.4 in.) length of nominally 7 mm (0.25 in.) tubing. The holes shall be spaced 13 ± 1 mm (0.5 ± 0.04 in.) apart with the first hole located 13 ± 1 mm (0.5 ± 0.04 in.) from the closed end, as shown in Fig. 7. The burner shall be positioned above the specimen holder so that the holes are placed above the specimen holder as shown in Fig. 7. The fuel fed to this burner shall be methane of 99 % minimum purity mixed with air in a ratio of approximately 50/50 by volume. The total fuel flow shall be adjusted to provide flamelets 25 mm (1 in.) long. When the gas/air ratio and its fuel flow rate are properly adjusted, approximately 6 mm (0.25 in.) of the flame length appears yellow in color.

9. Calibration of Equipment—Configuration A

9.1 *Calibration Burner*—A calibration burner as shown in Fig. 8 shall be provided that fits over the end of the pilot flame tubing with a gas-tight connection.

9.2 *Calibration Gas*—Methane of at least 99 % purity shall be used for calibration purposes.

9.3 *Wet Test Meter*—A wet test meter accurate to 0.2 L/min (0.007 ft³/min) shall be provided to measure the gas flow rate to the calibration burner. Prior to usage, the wet test meter shall be leveled and filled with distilled water to the tip of the internal pointer.

9.4 *Calibration Gas Manifold:*

9.4.1 A manifold shall be provided upstream of the wet test meter to control calibration gas flow. The manifold shall have four flow orifices controlled by needle valves that are preset to provide calibration gas at approximate (uncorrected for the

presence of water vapor) flow rates of 1, 4, 6 and 8 L/min (0.035, 0.140, 0.210, and 0.280 ft³/min) as indicated by revolution rate (measured by a stop watch accurate to 1 s) of the wet test meter. Output from each of the four flow orifices shall be controlled by a toggle on/off valve, and be plumbed into a single flow line so that the calibration gas flow rate to the calibration burner can be set at either 1, 4, 6, or 8 L/min (0.035, 0.140, 0.210, or 0.280 ft³/min).

9.4.2 The actual corrected value, *F*, of each of the flow rates shall be determined to an accuracy of 0.2 L/min (0.007 ft³/min), and these corrected values used for calibration calculations of heat release rate.

9.5 *Calibration Procedure:*

9.5.1 Replace the lower pilot burner with the calibration burner shown in Fig. 8.

9.5.2 Install the wet test meter. Ensure it is leveled and filled with distilled water. Ambient temperature and pressure of the water are based on the internal wet test meter temperature.

9.5.3 Turn on the air distribution system.

9.5.4 Turn on the radiant heat source and ensure that the heat flux density is 35.0 ± 0.5 kW/m².

9.5.5 Using the calibration gas manifold, set the baseline flow rate of 1 L/min of methane to the calibration burner, and light the burner. Measure the thermopile baseline voltage.

9.5.6 Immediately prior to recording the thermopile outputs in 9.5.7, precondition the chamber at a methane flow rate of 8 L/min. Do not record the thermopile output for this step as part of calibration.

9.5.7 Increase the gas flow to the burner to a higher flow rate and then decrease to the baseline flow rate. After 2 min of burning at each rate, monitor the thermopile output (millivolts) for a 10-s period, and record the average reading and decrease flow rate to the baseline flow of 1 L/min. This sequence of increasing and decreasing the methane flow rate is as follows: 1 - 4 - 1 - 6 - 1 - 8 - 1 - 6 - 1 - 4 L/min (0.035 - 0.140 - 0.035 - 0.210 - 0.035 - 0.280 - 0.035 - 0.210 - 0.035 - 0.140 ft³/min).

9.6 Compute the calibration factor for each upward rate step (that is: 1-4, 1-6, 1-8, 1-6, 1-4 L/min) according to the following formula:

$$k_n = 25.31 \cdot \frac{273}{T_a} \cdot \frac{(P - P_y)}{760} \cdot \frac{(F - F_0)}{(V_1 - V_0)} \cdot [\text{kW mV/m}^2] \quad (1)$$

where:

F = corrected upper flow rate of calibration gas, L/min (either 4, 6, or 8),

*F*₀ = corrected baseline flow rate of methane, L/min (approximately 1 L/min),

P = ambient atmospheric pressure, mm Hg,

*P*_{*y*} = water vapor pressure of wet test meter water temperature, mm Hg,

*T*_{*a*} = ambient temperature, K,

*V*₁ = thermopile voltage at upper flow rate, mV, and

*V*₀ = thermopile voltage at baseline flow rate, mV.

NOTE 3—The constant used in the above equation is derived as follows: 25.31 = (Heat content of methane at STP, 31.176 Btu/L) × (conversion factor of 0.0176 kW-min/Btu) / (area of a specimen, 0.02323 m²).

9.7 Average the five results and compute the percent relative standard deviation. If the percent relative standard deviation is

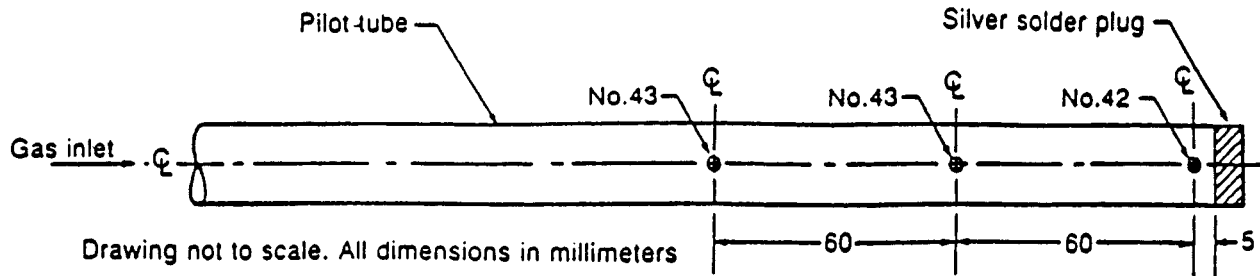

Wet Test Meter Measurements	Pilot Tube
Methane: 730 cc/min @ 29°C/738.2 torr	Type 304 SS
Air: 750 cc/min @ 29°C/738.2 torr	I.D.: 4.5 mm
	I.D.: 6.5 mm
	Length: approx. 400 mm

FIG. 6 Upper Pilot Tube-Outlet Hole Sizes and Configurations

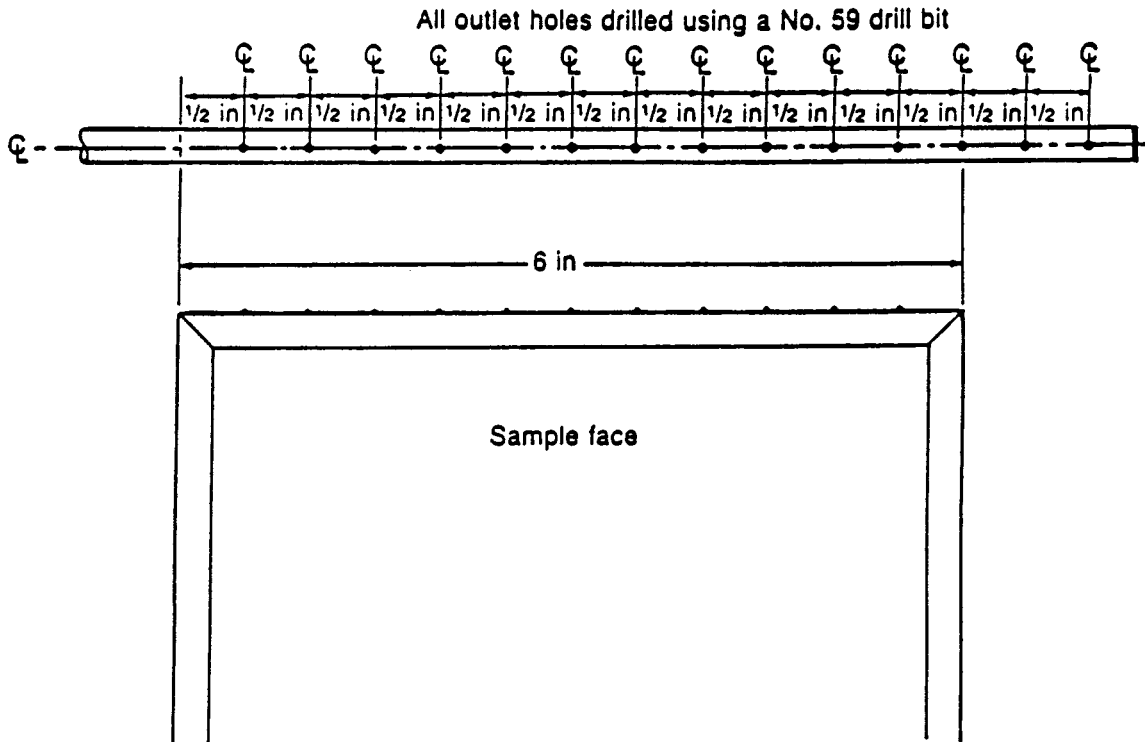

FIG. 7 Modification of the Upper Pilot Tube for the OSU Chamber

greater than 5 %, repeat the determination. If it is less than 5 %, use the average as the calibration factor.

10. Test Procedure and Calculations—Configuration A

10.1 Set the airflow to the equipment by adjusting the pressure differential across the orifice plate to 200 mm (7.87 in.) mercury.

10.2 Set the power supply to the Globars to produce a radiant flux density of $35.0 \pm 0.5 \text{ kW/m}^2$ at the point which the center of the front surface of the specimen will occupy when positioned for test.

10.3 Light the pilot flames and check that their positions are as described in 10.8. Activate the spark igniter if a spark igniter is used.

10.4 Place the specimen in the hold chamber with the radiation shield doors closed. Secure the airtight outer door, and start the recording devices. Hold the specimen in the hold chamber for $60 \pm 10 \text{ s}$.

10.5 Record, at least once per s, the thermopile millivolt output during the final 20 s of the hold time before the specimen is injected and report the average as the baseline thermopile reading (millivolts).

10.6 After recording the baseline reading and within a time frame not exceeding 3 s, open the radiation doors, inject the specimen into the burn chamber, and close the radiation doors. Record thermopile millivolt outputs at least once per s for the duration for the test.

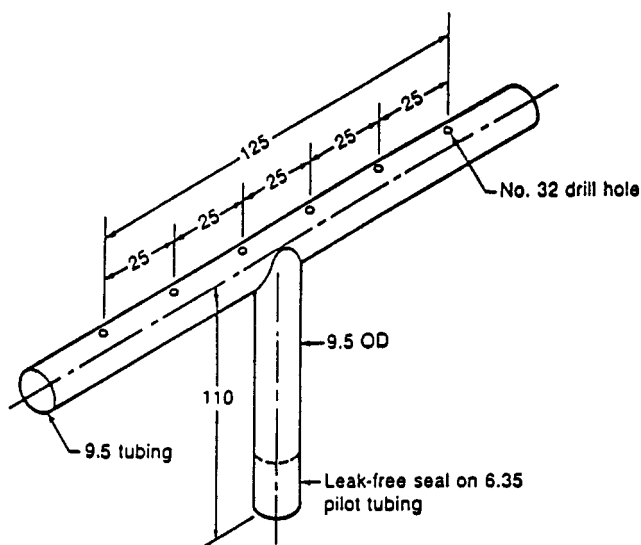

(Unless denoted otherwise, all dimensions are in millimeters.)
FIG. 8 Calibration Burner—Configuration A

10.7 After the test has run for 5 min, terminate the test and remove the sample.

10.8 Discard data from any test during which the lower pilot burner was extinguished for any period of time exceeding 3 s, or during which at least one of the upper pilot flamelets was extinguished for any period of time exceeding 3 s.

10.9 Calculate the heat release rate for any point of time from the reading of the thermopile output voltage, V , at that time as heat release rate by the following formula:

$$RHR = k_h \cdot (V - V_0) \quad (2)$$

where k_h and V_0 are the calibration factor and the thermopile millivolt reading at the baseline, respectively.

10.10 Determine and record the maximum heat release rate during the 5-min test.

10.11 Compute and record the total heat released after the first 2 min of testing by integrating the heat release rate vs. time curve during the first 2 min.

10.12 Clean the thermopile hot junctions to remove soot after testing each specimen. Do not disturb the position of the thermocouples. Ensure that the thermocouples are in their proper position before proceeding with the next specimen.

NOTE 4—A small soft-bristled brush has been found satisfactory for cleaning the thermocouple junctions. A template facilitates checking thermocouple positioning.

11. Release Rate Apparatus—Configuration B

11.1 *Release Rate Apparatus* (Fig. 9) is used to determine release rates of heat and smoke by this test method. All exterior surfaces of the apparatus, except the holding chamber, shall be insulated with 25-mm thick, low density, high-temperature, fiber glass board insulation.⁷ A gasketed door, through which the sample injection rod slides, forms an airtight closure on the specimen hold chamber.

11.2 *Thermopile*—The temperature difference between the air entering the environmental chamber and that leaving is

monitored by a thermopile having five hot and five cold, 24-gage Chromel-Alumel Type K thermocouple junctions. The loop to be formed by the thermocouple junction shall be 1.4 ± 0.3 mm (0.050 ± 0.010 in.) in diameter. The cold junctions shall be located in the pan below the air distribution plate. The hot junctions shall be located 10 mm (0.38 in.) below the top of the chimney. One of the hot junctions shall be placed at the center of the chimney's cross section, and the other four shall be placed on the chimney diagonals 30 mm (1.18 in.) from the center of the thermopile (see 11.5). The use of a compensator tab, as described in 11.2.2 through 11.2.5, is not needed if this thermopile is used.

11.2.1 *Thermopile for Research Configuration*—Alternatively, the temperature difference between the air entering the environmental chamber and that leaving is monitored by a thermopile having three hot and three cold, 24-gage Chromel-Alumel Type K junctions. The hot junctions are spaced across the top of the exhaust stack. Two hot junctions are located 25 mm from each side on diagonally opposite corners and the third in the center of the chimney's cross 14 mm below the top of the chimney. The cold junctions are located in the pan below the lower air distribution plate (see 11.5). If this thermopile is used, the use of a thermal inertia compensator, as described in 11.2.2 through 11.2.5, is recommended.

11.2.2 *Thermal Inertia Compensator*—A compensator tab is made from 0.55-mm stainless steel sheet, 10 by 20 mm. An 800-mm length of 24-gage Chromel-Alumel Type K, glass-insulated duplex thermocouple wire shall be welded or silver soldered to the tab as shown in Fig. 10, and the wire bent back so it is flush against the metal surface.

11.2.3 The compensator tab shall be mounted on the exhaust stack as shown in Fig. 11 using a 6/32-round head machine screw, 12 mm-long. Add small (approximately 4.5-mm inside diameter, 9-mm outside diameter) washers between the head of the machine screw and the compensator tab to give the best response to a square wave input. One or two washers should be adequate. The sharpness of the square wave can be increased by changing the ratio of the output from the thermopile and compensator thermocouple that is fed to the recorder. The ratio is changed by adjusting the 1-K Ω variable resistor (R_1) of the thermopile bleeder shown in Fig. 12. When adjusting compensation keep R_1 as small as possible. Adjustment of the compensator shall be made during calibration at a heat release rate of 7.0 ± 0.5 kW (see 12.1).

11.2.4 Adjust washers and variable resistor (R_1) so that 90 % full scale response is obtained in 8 to 10 s. There shall be no overshoot as shown in Fig. 13(a). If an insufficient number of washers is added or if R_1 is too small, the output with square wave input will look like Fig. 13(b). If too many washers are added and if R_1 is too large, the output will look like Fig. 13(a).

11.2.5 Subtract the output of the compensator from the thermopile. The junctions enclosed in the dotted circle of Fig. 12 are kept at the same constant temperature by electrically

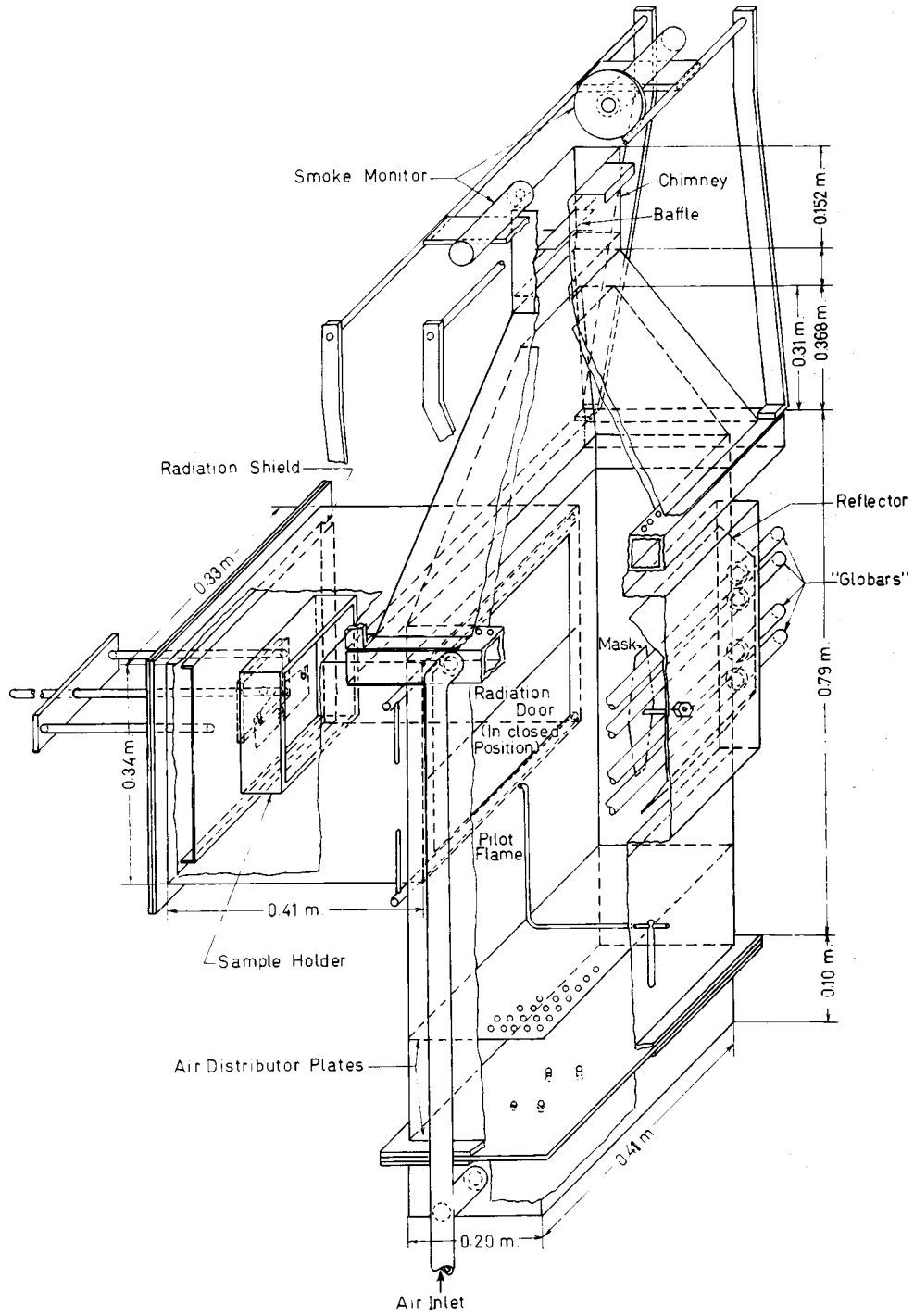

FIG. 9 Release Rate Apparatus—Configuration B

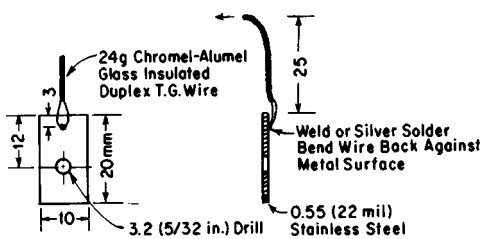

FIG. 10 Compensator Tab

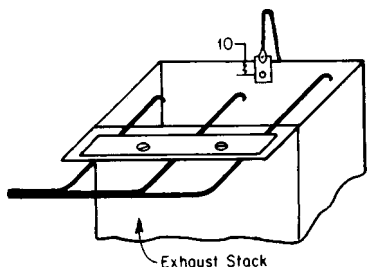

FIG. 11 Compensator Tab Mount

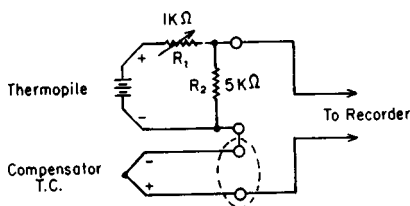

FIG. 12 Wiring Diagram

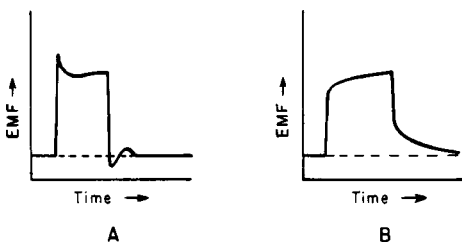

FIG. 13 Square Wave Response

insulating the junctions and placing them on the pipe carrying air to the manifold, then covering them and the pipe with thermal insulation.

11.3 *Smoke Monitor*—A photometer (Fig. 14) measures the

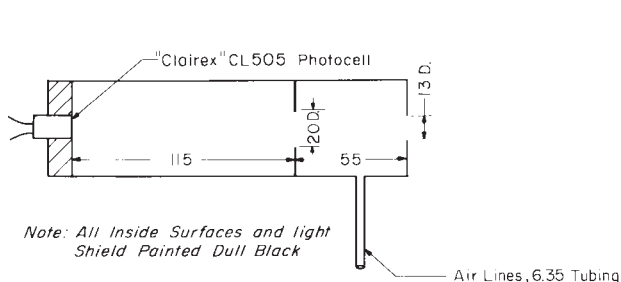

FIG. 14 Smoke Monitor

percent of light transmitted through the gases leaving the apparatus. A photocell⁸ and circuitry shown in Fig. 15 shall be used and calibrated in accordance with 12.2. The light source shall be No. 82 miniature incandescent lamp operated at its recommended current, 1.0 A.

11.3.1 The smoke monitor apparatus shall be mounted with the center line 25 mm above the exhaust stack and centered parallel to the length of the opening. The two parts of the optical system shall be 130 mm apart. A continuous flow of constant temperature air, approximately 0.004 m³/min, shall be maintained to the air lines to prevent smoke from entering the smoke monitor.

11.4 *Radiation Source*—A radiant heat source for generating a flux up to 100 kW/m², using four silicon carbide elements,⁹ Type LL, 20 by 12 by 5/8, nominal resistance 1.5 Ω, is shown in Fig. 16 and Fig. 17. The silicon carbide elements are mounted in the stainless steel panel box by inserting them through 15.9-mm holes in 0.8-mm thick ceramic fiber or asbestos board. Locations of the holes in the pads and stainless steel cover plates are shown in Fig. 17. The diamond shaped mask of 24-gage stainless steel is added to provide uniform heat flux over the area occupied by the 150 by 150-mm vertical sample. A power supply of 16.5 kVA, adjustable from 0 to 270 v¹⁰ is required.

11.5 *Air Distribution System*—The air entering the environmental chamber is distributed by a 6.3-mm thick aluminum plate having eight No. 4 drill holes, 51 mm from sides on 102-mm centers, mounted at the base of the environmental chamber. A second plate of 18-gage steel having 120 evenly spaced No. 28 drill holes is mounted 150 mm above the aluminum plate. A well regulated air supply is required.

11.5.1 The air supply manifold at the base of the pyramidal section has 48 evenly spaced No. 26 drill holes 10 mm from the

⁸ The sole source of supply of the apparatus known to the committee at this time is Clairex, Plano, TX. If you are aware of alternative suppliers, please provide this information to ASTM Headquarters. Your comments will receive careful consideration at a meeting of the responsible technical committee,¹ which you may attend.

⁹ The sole source of supply of the apparatus known to the committee at this time is Carborundum Co., Globar Div., Niagara Falls, NY. If you are aware of alternative suppliers, please provide this information to ASTM Headquarters. Your comments will receive careful consideration at a meeting of the responsible technical committee,¹ which you may attend.

¹⁰ If a heat flux of up to 100 kW/m² is desired, a separate power supply for each pair of elements can be used where maximum voltage is less than 270 V.

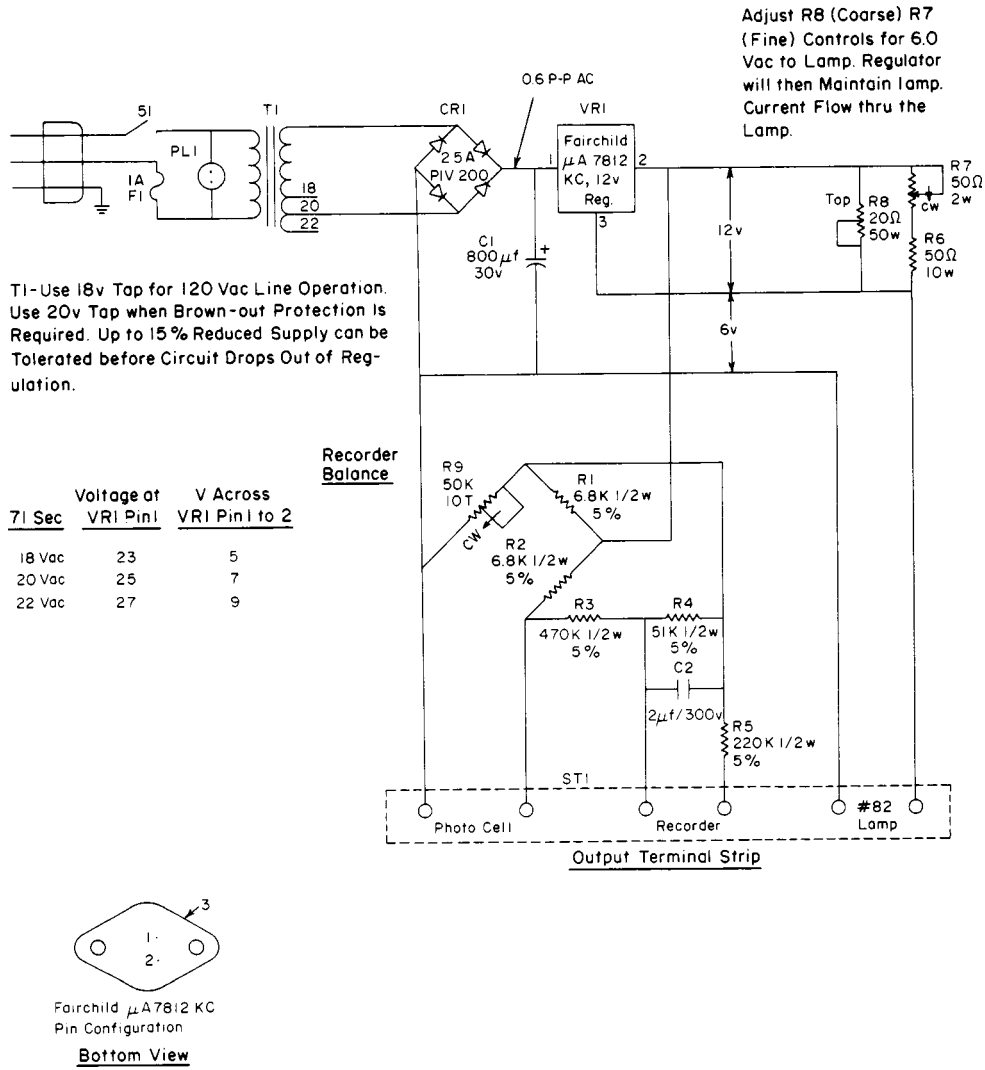

FIG. 15 Constant Current Lamp Supply and Photocell Bridge Circuit

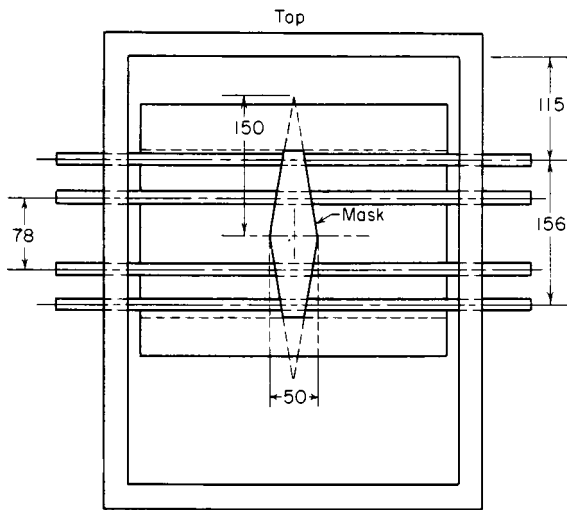

FIG. 16 Globar Radiant Panel

environmental chamber when total air flow to apparatus is controlled at $0.04 \text{ m}^3/\text{s}$.

11.6 *Exhaust Stack*—An exhaust stack, 133 by 70 mm in cross section and 254 mm long, fabricated from 28 gage stainless steel is mounted on the outlet of the pyramidal section. A 25 by 76-mm plate of 31 gage stainless steel is centered inside the stack, perpendicular to the air flow, 75 mm above the base of the stack.

11.7 *Specimen Holders*—Vertical specimen holders shall be attached to the injection rod using the vertical support shown in Fig. 18. Two different types of specimen holders shall be provided, one for 150 by 150-mm specimens to be tested in vertical orientation (Fig. 19) and the other for 110 by 150-mm specimens in horizontal orientation (Fig. 20). Each holder is provided with a V shaped spring pressure plate and 12.7-mm

inner edge of the manifold so $0.03 \text{ m}^3/\text{s}$ of air flows between the pyramidal sections and $0.01 \text{ m}^3/\text{s}$ flows through the

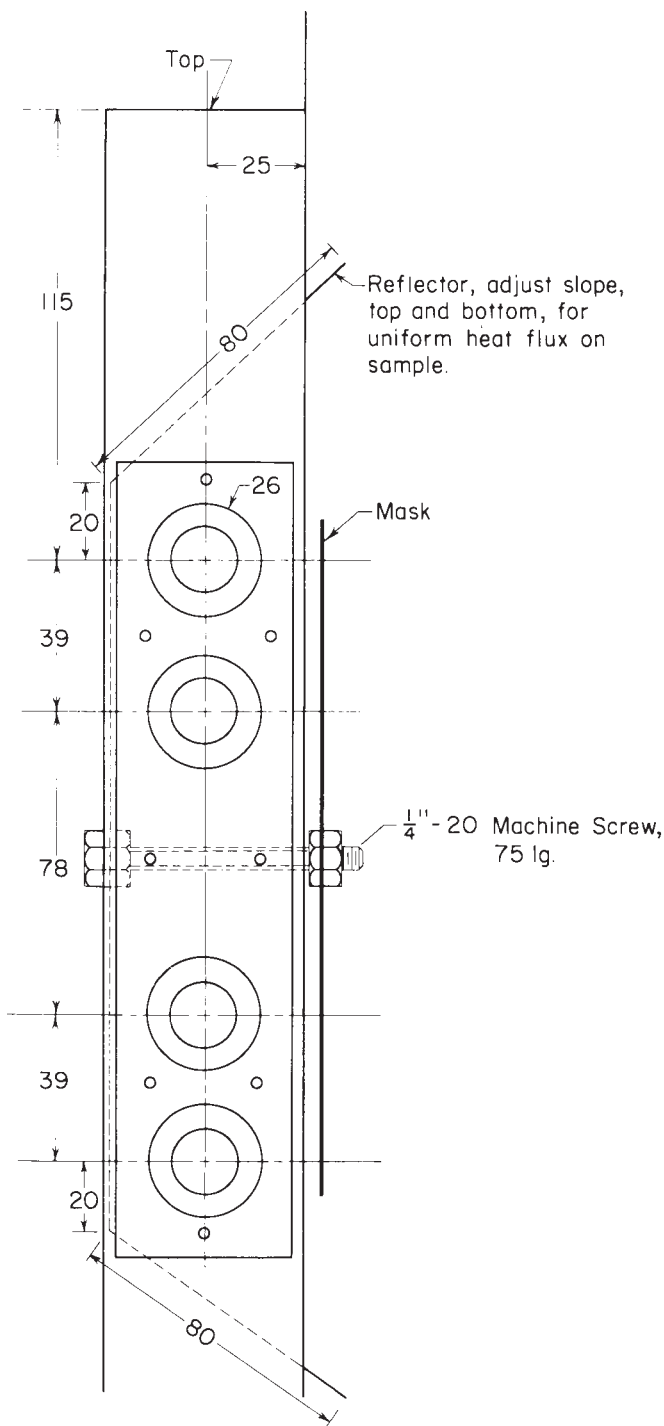

FIG. 17 Locations of Holes in Globar Radiant Panel

backing plate of rigid insulation board¹¹ having a density of $320 \pm 80 \text{ kg/m}^3$ and thermal conductivity of $0.08 \pm 0.01 \text{ W/m}\cdot\text{K}$. The position of the spring pressure plate may be

¹¹ The sole source of supply of the apparatus known to the committee at this time is Babcock/Wilcox Refractories, Augusta, GA. If you are aware of alternative suppliers, please provide this information to ASTM Headquarters. Your comments will receive careful consideration at a meeting of the responsible technical committee,¹ which you may attend.

changed to accommodate different specimen thickness by inserting a retaining rod in different holes of the specimen holder frame.

11.7.1 The unexposed surfaces of the specimen shall be covered with two thicknesses of 0.025-mm aluminum foil pressed tightly to sides and back. This foil shall be carried out and over the lip on the horizontal holder to form a 8 ± 3 -mm high shield from radiant heat immediately to the side (see Fig. 20).

11.7.2 Pans or plates for supporting specimens that cannot be mounted in the holders (see 11.7) or are to be tested in an unrestrained condition shall be constructed so the weight of the holder is minimized to reduce heat capacity of the supporting structure. For horizontal specimens that melt, and for thermally thin specimens, the aluminum foil boat (see 11.7.1) shall be set on or backed by the 12-mm rigid insulation board described in 11.7.

11.7.3 The adjustable radiation shield (see Fig. 9) on the vertical specimen holder, which covers the opening made when the radiation doors are in their open position and the specimen is inserted, is adjusted to position the front surface of the specimen 100 mm from the entrance of the environmental chamber.

11.7.4 The frame for the horizontal radiation reflector is shown in Fig. 21, and the horizontal assembly in the burn position is shown in Fig. 22.

11.8 *Radiation Reflector for Horizontally Mounted Specimens*—A new 320 by 225-mm sheet of 0.025-mm aluminum foil shall be placed over the rod supports before each test with bright side toward the panel. The foil shall be supported by crimping around all edges with a 25-mm overlap.

11.9 *Radiometers*—Total-flux meters¹² (calorimeters) shall be used to measure the total heat flux for both horizontal and vertical specimens at the point where the center of the specimen surface is located at the start of the test. The total-flux meters shall have view angles of 180° and be calibrated for incident flux. When positioned to measure flux, the sensing surface of the flux meter for vertical specimens shall extend beyond any solid supporting device so that air heated by such a support does not contact the sensing surface of the flux meter.

11.10 *Lower Pilot Burner*—Pilot-flame tubing shall have a 11.3-mm outside diameter, a 0.8-mm wall, and stainless steel tubing. Fuel shall be methane or natural gas having 90 % or more methane. A methane-air mixture, 120 cm^3/min gas, and 850 cm^3/min air shall be the fuel mixture fed to the lower pilot flame burner. For the pilot flame described in 11.11.3, no air is used.

11.11 *Pilot-Flame Positions*—In addition to piloted and nonpiloted mode of operation, pilot ignition of a specimen may be accomplished by locating the pilot flame at different positions relative to the sample surface so that the flame may or may not impinge on the specimen surface. The location chosen depends on the nature of ignition to be simulated by the

¹² The sole source of supply of the apparatus known to the committee at this time is Hy-Cal Engineering, Santa Fe Springs, CA. If you are aware of alternative suppliers, please provide this information to ASTM Headquarters. Your comments will receive careful consideration at a meeting of the responsible technical committee,¹ which you may attend.

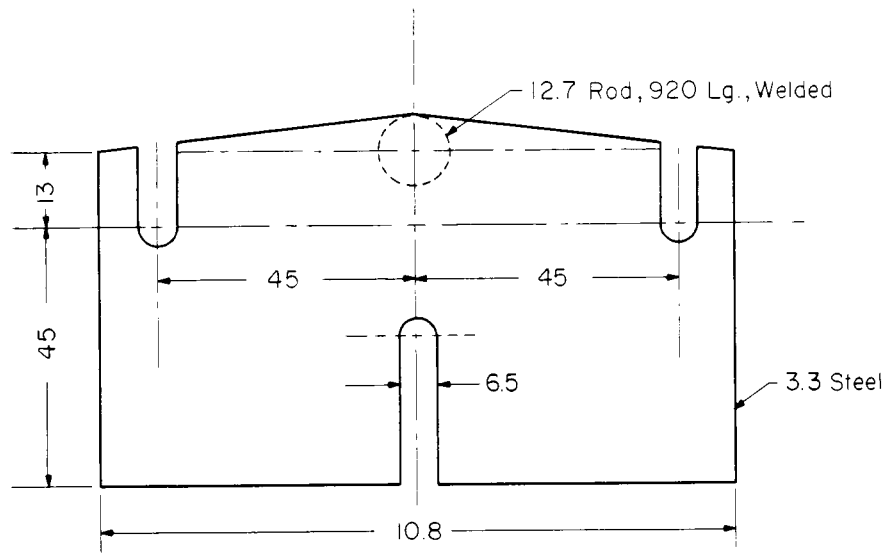

VERTICAL SUPPORT

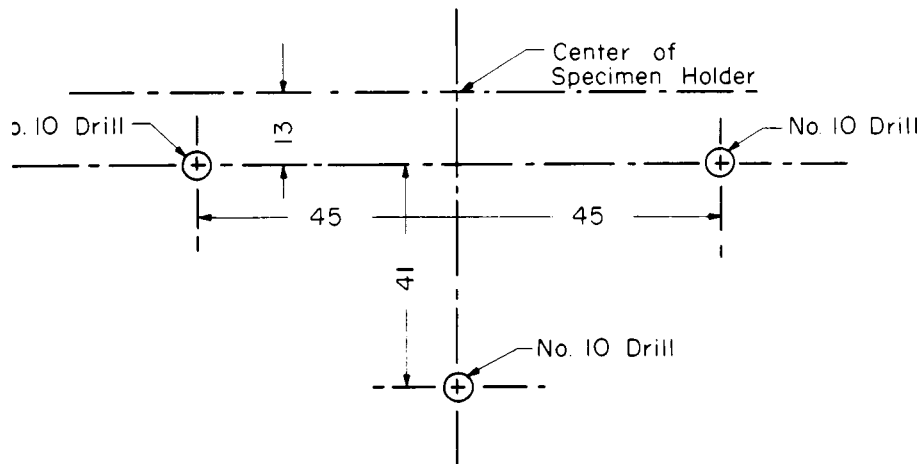

TEMPLATE FOR MOUNTING BOLTS
VERTICAL MOUNT

FIG. 18 Vertical Holder Mount

test. In all piloted ignitions, the lower pilot flame size shall be in accordance with 11.10. Pilot positions are described in 11.11.1 through 11.11.3. Pilot ignition by an impinging flame is required when release-rate information is wanted at a heat flux below which the pyrolysis rate of the specimen can maintain a combustible gas phase. At heat fluxes above that producing a combustible gas mixture over the surface of the sample, either piloted, point-ignition, or gas phase ignition may be used. In gas-phase ignition, surface involvement is usually very rapid, eliminating the progressive-involvement phase of the release

rate curve. If the rate of surface involvement at a given flux is to be observed, piloted-point-ignition shall be used.

11.11.1 *Pilot Ignition—Vertical Specimen with Impinging Flame*—Normal position of the end of the pilot burner tubing is 10 mm from and perpendicular to the exposed vertical surface of the specimen. The centerline at the outlet of the burner tubing shall intersect the vertical centerline of the sample, 5 mm above the lower edge of the specimen. An upper, nonimpinging pilot burner shall also be used. The burner and its location are described in 11.11.3.

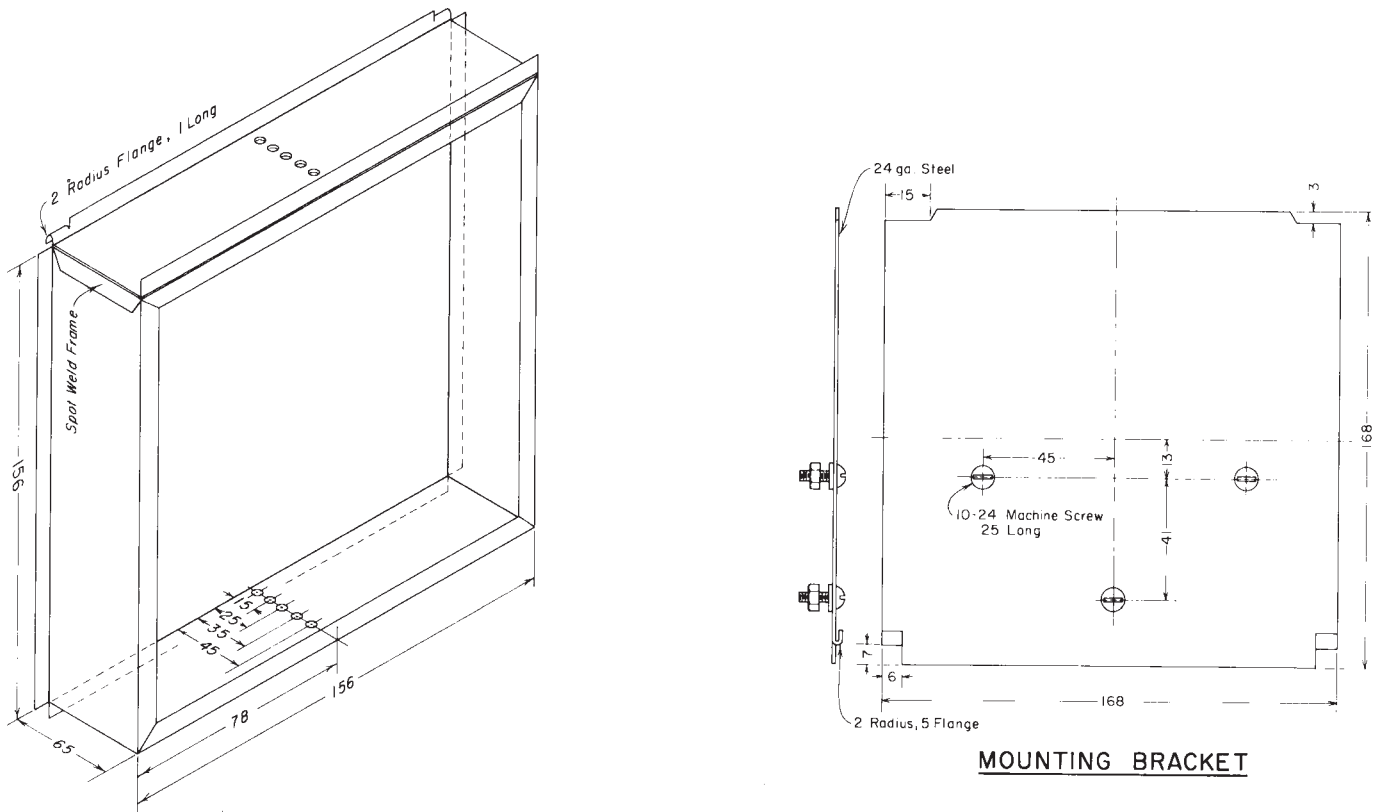

FIG. 19 Vertical Specimen Holder

11.11.2 *Piloted Ignition—Horizontal Specimen with Impinging Flame*—Normal position of the end of the burner tubing is 10 mm above and perpendicular to the exposed horizontal surface of the specimen. The centerline at the outlet of the burner intersects the center of the specimen.

11.11.3 *Pilot Ignition—Vertical Specimen without Impinging Flame*—The pilot burner shall be a straight length of 6.3-mm outside diameter, 0.8 mm wall, and stainless steel tubing 360 mm long. One end of the tubing shall be closed, and three No. 40 drill holes, 60 mm apart drilled into the tubing for gas ports, all radiating in the same direction. The first hole shall be 5 mm from the closed end of the tubing. The tube is inserted into the environmental chamber through a 6.6-mm hole drilled 10 mm above the upper edge of the window frame. The tube is supported and positioned by an adjustable Z-shaped support mounted outside the environmental chamber above the viewing window. The tube is positioned above and 20 mm behind the exposed upper edge of the specimen. The middle hole shall be in the vertical plane perpendicular to the exposed surface of the specimen that passes through its vertical centerline and shall be pointed toward the radiation source. Fuel gas to the burner shall be methane or natural gas with at least 90 % methane. Flow of fuel gas shall be adjusted to produce flame lengths of 25 mm. An air-gas mixture shall not be used for this pilot burner.

12. Calibration of Equipment—Configuration B

12.1 *Heat Release Rate*—A burner as shown in Fig. 23 shall be placed over the end of the pilot flame tubing using a gas tight connection. The gas to the calibration burner shall be

accurately metered, that is, by a wet test meter, and set at a low flow rate. The calibration is conducted without power to the radiation source. The gas shall be at least 90 % methane and have an accurately known net heating value. The output of the recorder is “zeroed.” Then the gas flow to the burner shall be increased to a higher, preset value and allowed to burn at this steady rate for an accurately measured time interval of 4.0 min. The flow of gas shall be changed abruptly to its initial low flow, or “zero,” rate and continued for 4.0 min. At the end of 4.0 min, the base line shall be adjusted to zero if necessary and the gas flow again increased to the higher preset value and allowed to burn for 4.0 min, after which the gas flow is again returned to its low flow rate. The sequence is repeated until a constant increase and consistent return to the “zero” base line is achieved.

12.1.1 The difference in flow between the low and high settings for gas flow, multiplied by its net heating value, shall be used as the rate of heat release. The output of the differential temperature recorder after reaching a steady state value, is the output corresponding to that heat release rate. At least three levels of heat release shall be used. The heat release rate shall not exceed 7.75 kW, nor be less than 1.5 kW when calibrating.

12.2 *Smoke Photometer Calibration*—Four neutral-density filters having accurately known optical densities of approximately 0.1, 0.2, 0.4, and 1.0 shall be used to calibrate the smoke photometer. The output of the photometer circuit is “zeroed” with no filter or smoke in the light path (zero absorbance). Then each of the filters described above is alternatively placed in the light path, and finally the light path

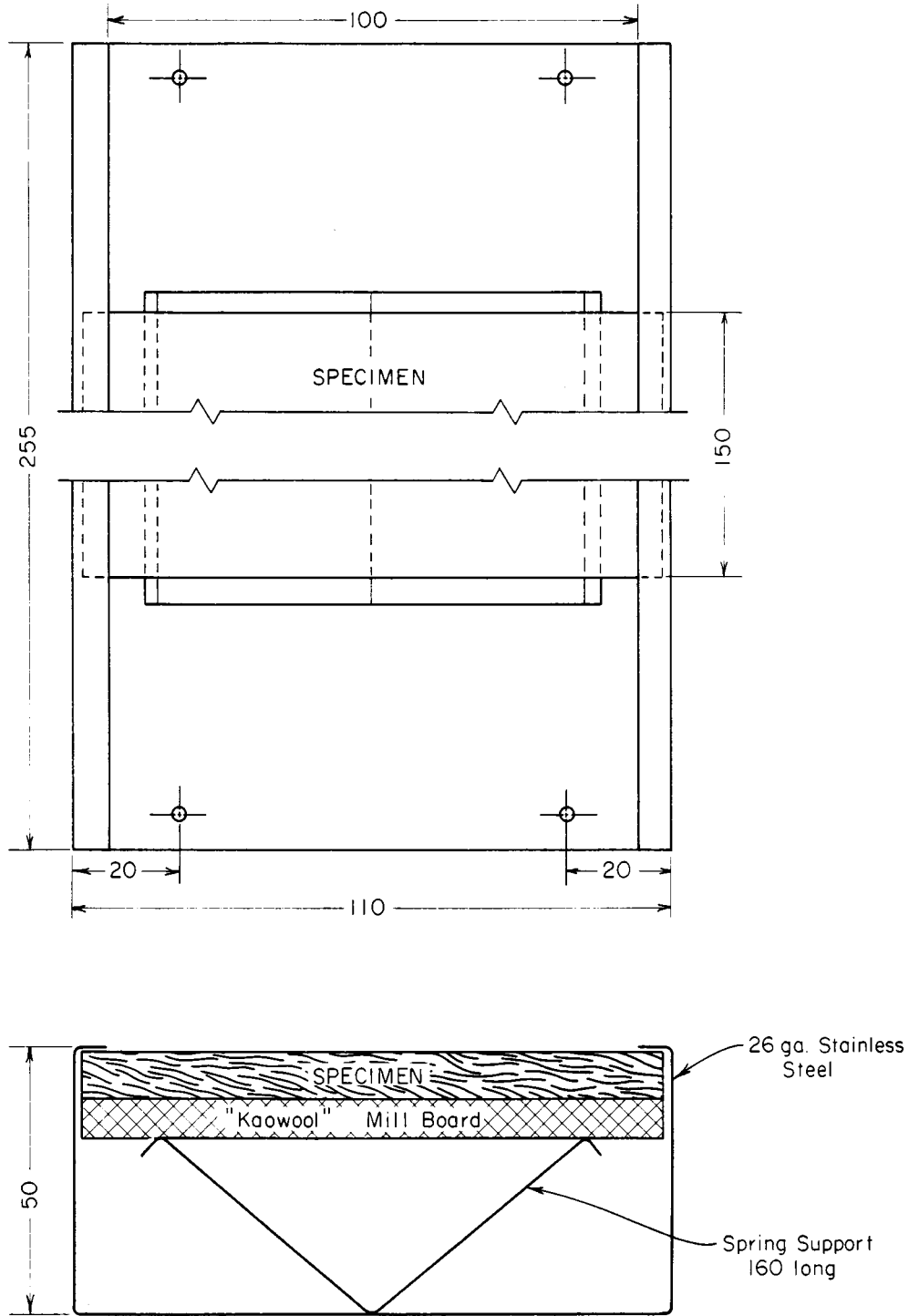

FIG. 20 Horizontal Specimen Holder

is completely obscured (0 % transmission). A plot of percent transmission (% T) versus recorder output is made. For the photometer in 11.3, this will not be a straight line. Using the relationship, optical density = $\log (100/\% T)$, a curve of values of optical density (absorbance) versus recorder output is constructed.

12.2.1 The optical density of the neutral density filters shall be determined at a wave length of 580 nm.

12.2.2 After the optical density versus recorder output relationship has been determined, minor variations due to aging of the light source, or its replacement, shall be compensated for by adjusting the 50- Ω , 2-W resistor to produce the same chart reading for a given neutral density filter.

12.2.3 The recorder's sensitivity shall be adjusted so that a full-scale chart reading is produced by a change in percent transmission of (approximately) from 100 % to 30 %.

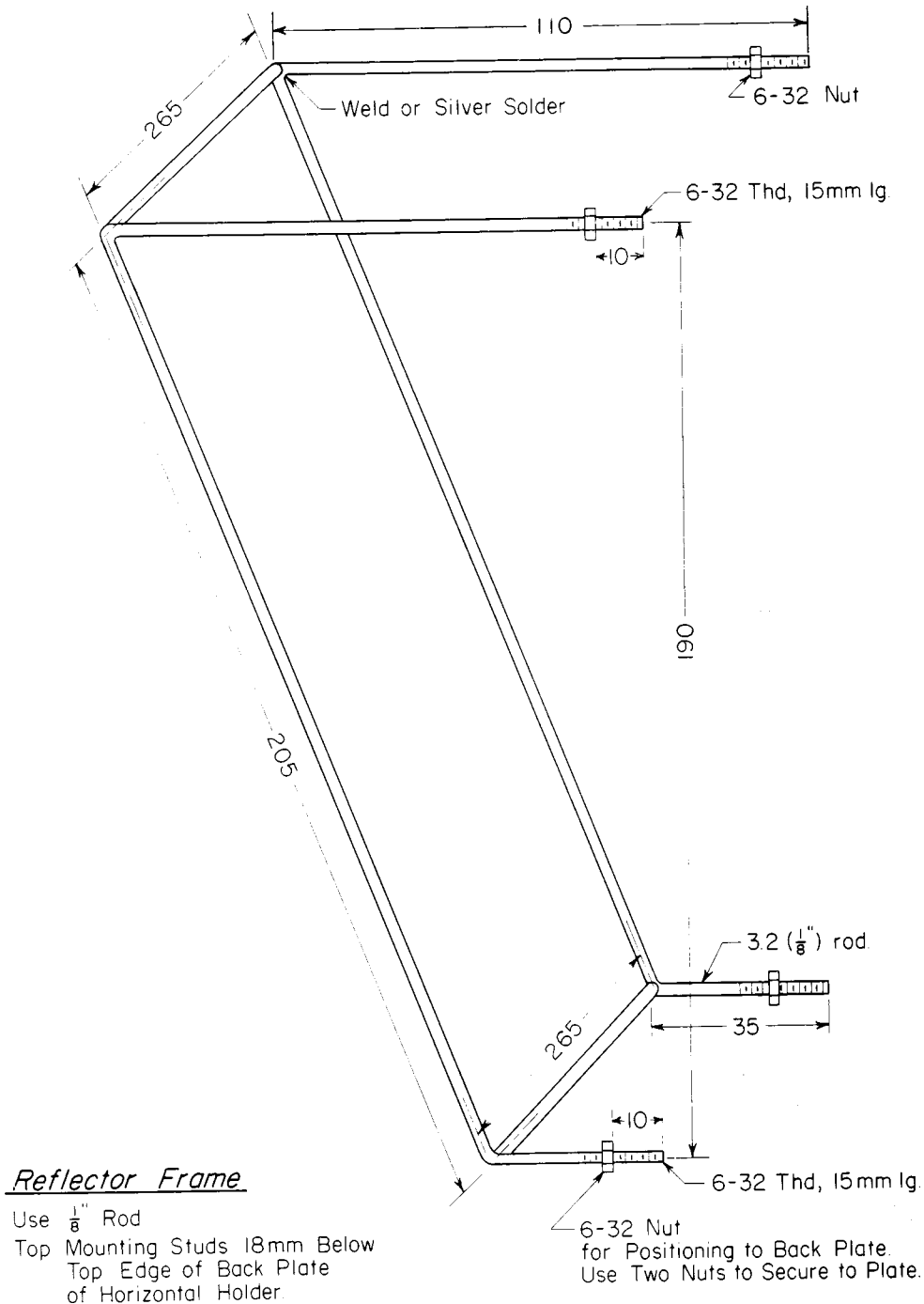

FIG. 21 Reflector Frame

12.3 *Flux Uniformity*—Uniformity of flux over the specimen shall be periodically checked and also checked after each heating element change to determine if it is within the acceptable limits of $\pm 5\%$.

13. Test Procedure—Configuration B

13.1 If using piloted ignition, light the pilot flame and check its position (see 11.11).

13.2 Set the power supply to the radiant panel to produce the desired radiant flux. Measure the flux at the same point as

the surface at the center of the specimen will occupy when positioned for test. After adjusting the air flow through the equipment to the desired rate, measure the radiant flux with the lower pilot flame displaced to the side of the environmental chamber.

13.3 Set the air flow to the equipment at $0.04 \text{ m}^3/\text{s} \pm 0.001$ (at atmospheric pressure and 23°C). Adjust the stop on the vertical specimen holder rod so that the exposed surface of the

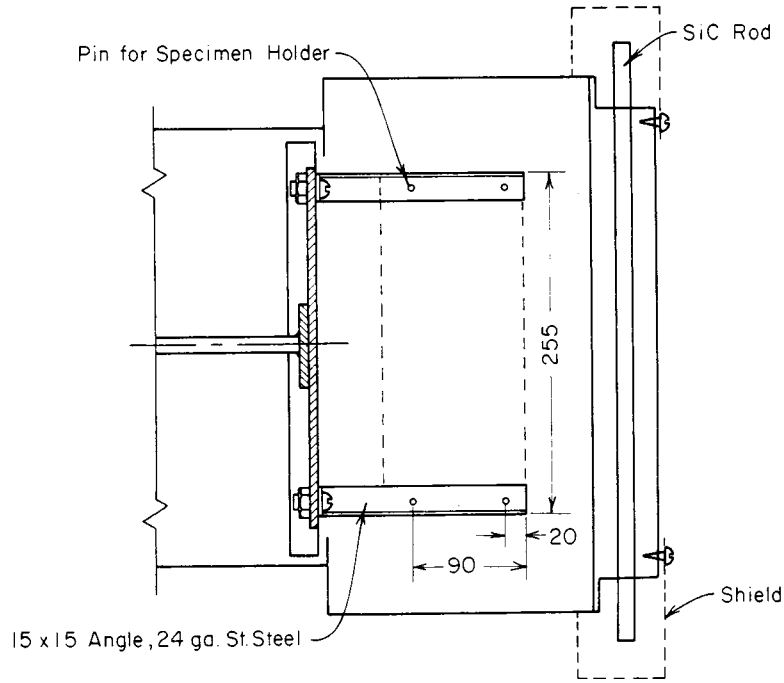
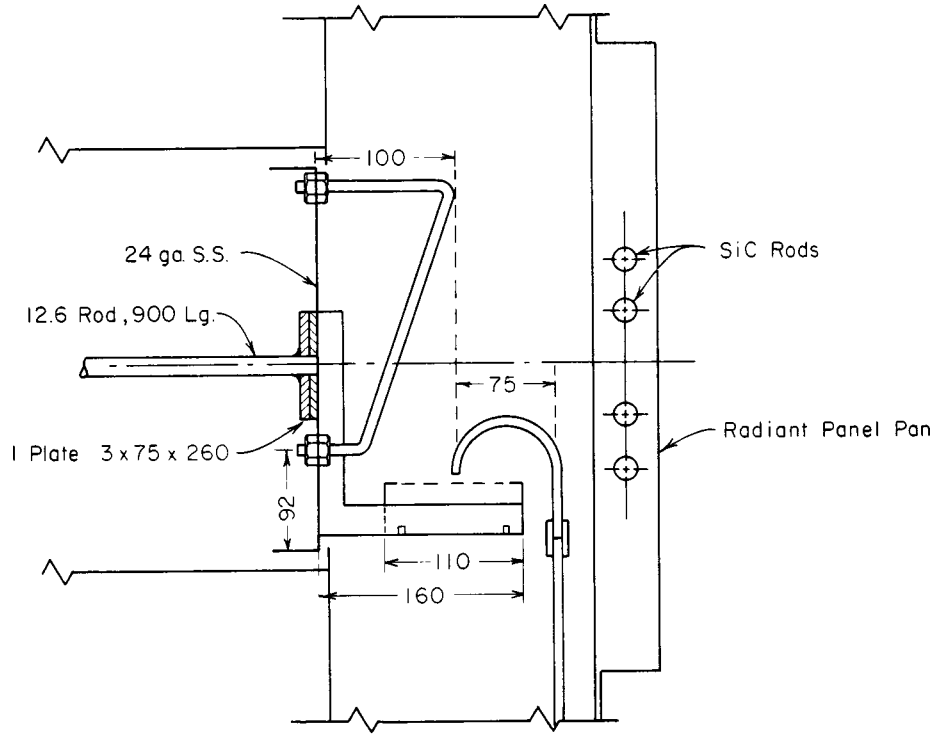

FIG. 22 Horizontal Configuration

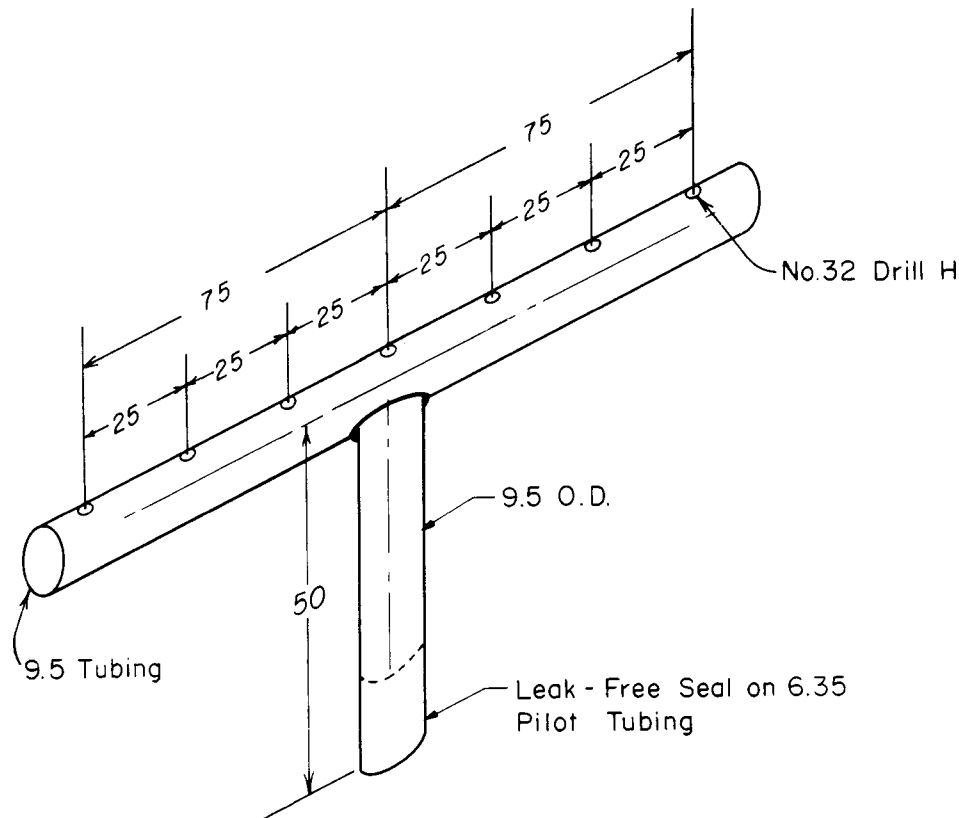

FIG. 23 Calibration Burner—Configuration B

specimen is positioned 100 mm from the entrance when injected into the environmental chamber.

NOTE 5—Proper air flow may be set and monitored by either (1) an orifice meter designed to produce a pressure drop of at least 200 mm of the manometric fluid, or by (2) a rotometer (variable orifice meter) with a scale capable of being read to $\pm 0.0004 \text{ m}^3/\text{s}$.

13.4 Before the specimen is inserted, maintain steady state conditions so that the radiant flux does not change more than 0.5 kW/m^2 over a 10-min period.

13.5 Place the specimen in the hold chamber with the radiation shield doors closed. Secure the air-tight outer door, start recording devices, and set the output of the thermopile and smoke particle detector to “zero” on the recorder. “Zero” conditions are those existing at the time immediately before the specimen is injected. Retain the specimen in the hold chamber $60 \pm 10 \text{ s}$ before injection.

13.6 When the specimen is to be inserted, open the radiation doors, and insert the specimen into the environmental chamber.

13.7 Unless immediate ignition occurs, a negative heat release will occur at elevated exposures due to heat absorption by the cold specimen holder. Data-acquisition devices shall have the capability of following these negative outputs. Perform a blank run for correction for heat absorption by the holder (see 13.10).

13.8 Injection of the specimen marks time zero. Make a continuous record of the output from the photometer circuit and thermopile during the time the specimen is in the environmental chamber.

13.9 Normal test duration time is 10 min. For specimens that are totally consumed in less than 10 min, terminate the test when heat and smoke-particulate release have ceased.

13.10 Perform a blank run (base line) test during which the specimen holder, without specimen, shall be injected and heat release versus time data taken. At low heat fluxes, corrections for heat absorbed by the specimen holder should be negligible, but at a heat flux over 10 kW/m^2 , a correction due to the specimen holder may be necessary (see 14.1.1).

13.11 Make at least three determinations. If the release rate value or values being compared for a given specimen are outside the range described in 16.3, a greater number of replicate determinations is required (see 16.4).

14. Calculations—Configuration B

14.1 *Heat Release Rate*—Heat release rates are calculated from the chart reading of the thermopile output, the exposed surface area of the specimen, and the constant k_H that is obtained from calibration runs as follows:

$$k_H = \frac{RHR}{C} \quad (3)$$

where:

- k_H = proportionality constant, unit chart reading,
- RHR = rate of heat release, kW, and
- C = chart reading.

Then

$$RHR = k_H \cdot (C)/A \quad (4)$$

where:

- RHR = rate of heat release, kW/m²,
 C = chart reading,
 k_H = proportionality constant, unit chart reading, and
 A = exposed surface area of specimen, m².

14.1.1 Determine heat release rates from chart readings as a function of time. Take sufficient points along the time axis to faithfully reproduce 0.10 cycle/s fluctuations. Smoothed values every 5 s are adequate, and may be taken less frequently when heat release rates change slowly. When blank run corrections (see 13.10) are greater than 3 % of the maximum heat release rates, apply them to the observed values.

14.2 *Smoke Release Rate*—Using the optical density versus the chart-reading plot (see 12.2), calculate the values of optical density (D) at the same elapsed time selected for calculating heat release rates.

14.2.1 As described, air having a concentration of one SMOKE unit per cubic metre reduced the percent transmission of light through 1 m of this air to 10 %, that is, optical density (absorbance) = 1.0.

14.2.2 Calculate SMOKE release rate, expressed in SMOKE units per minute per square metre of exposed surface area of the specimen as follows:

$$\text{SMOKE Release Rate} = \text{SRR} = \frac{D}{kLA} \cdot \left(\frac{V_o}{t} \right) \quad (5)$$

where:

- k = absorption coefficient = 1.0 m²/SMOKE,
 D = optical density (absorbance) = log (100/%T),
 L = light path = 0.134 m (stack width),
 A = exposed surface area of specimen, m²,
 $\frac{V_o}{t}$ = flow rate of air leaving apparatus, m³/min,
 $\frac{V_o}{t} = \frac{V_i}{t} \times \frac{T_o}{T_i}$,
 $\frac{V_i}{t}$ = flow rate of air entering apparatus, m³/min, and
 T_p, T_o = absolute temperature (Note 6) of air in and out of apparatus, respectively.

14.3 *Cumulative Heat and Smoke Release*—Heat and visible smoke particles released between any two points in time are given by the area under the respective curves for release rate versus time between those points.

NOTE 6—Major temperature correction, that is, maximum difference in T_i and T_o occurs when operating at a high heat flux and high heat release rates. At conditions of low heat release, an average temperature of effluent air (and therefore constant volumetric flow rate) can be assumed without significant error.

15. Report

15.1 The report shall include the following:

15.1.1 Full description of the material, product, or assembly tested, including mass, density, thickness, and name or commercial identification.

15.1.2 Name of sample manufacturer (if known) and of test requester.

15.1.3 Date and identification number of the report.

15.1.4 Orientation of specimen and detailed description of mounting procedure.

15.1.5 Radiant heat flux to specimen, kW/m².

15.1.6 Description of ignition procedure used (including information on use of pilot igniter).

15.1.7 Time to ignition, in s.

15.1.8 Peak rate of heat release, in kW/m².

15.1.9 Total heat released during the first 2 min of the test in kW/(min m²).

15.1.10 Total heat released during the entire test, in kW/(min m²).

15.1.11 The calibration factor, k_H .

15.1.12 Data giving rates of heat, in kW/m², as a function of time, either graphically or tabulated at intervals no greater than 10 s.

15.2 When smoke release has been measured report the following:

15.2.1 The maximum rate of smoke released during the test, in SMOKE/(m² min).

15.2.2 The total smoke released during the test, in SMOKE/m².

15.2.3 The total smoke released during the first 2 min of the test in SMOKE/m².

15.2.4 Data giving release rates of smoke in SMOKE/(m² min), as a function of time, either graphically or tabulated at intervals no greater than 10 s.

15.3 When melting, sagging, delaminating, or other behavior that affects the exposed surface area or mode of burning occur, these behaviors shall be reported, together with the time at which such behaviors were observed.

16. Precision and Bias¹³

16.1 The precision of the test method is still being established, although preliminary round-robin tests indicate the following:

16.2 Due to base line “noise,” sensitivity of sensors, and repeatability of base line setting, absolute values are no better than ± 0.03 kW for heat release and 0.025 SMOKE/min for smoke release rate. With permissible base line drift and variation in setting, permissible base line differences for 3, 5, and 10-min heat and smoke releasers are ± 0.01, 0.018, and 0.03 MJ, and ± 0.10, 0.17, and 0.33 SMOKE, respectively. Note that the surface area for vertical and horizontal specimens is 0.0225 m² and 0.0150 m² respectively. Therefore, the repeatability for a heat release base line setting for a horizontal specimen is 2.0 kW/m².

16.3 For samples that burn from a constant surface area, the precision of the method can be expressed as follows:

$$S_i = AX_i + B \quad (6)$$

where:

- S_i = overall precision as standard deviation for parameter i ,
 X_i = value of parameter i , and
 A and B = constants given in Table 1.

16.4 Additional round-robin tests are being conducted to obtain a better measure of reproducibility.

¹³ Supporting data are available on loan from ASTM Headquarters. Request RR: E05-1005.

TABLE 1

Parameter	Units of S_{ii} and X_i	A	B (Vertical)	B (Horizontal)
Single Laboratory				
Rate of heat release, max	kW/m ²	0.07	1.3	2.0
Heat released, 10 min	MJ/m ²	0.04	1.3	2.0
SMOKE release rate, max	SMOKE/min, m ²	0.13	4.5	6.8
SMOKE released, 10 min	SMOKE/m ²	0.05	15.	22.
Multilaboratory				
Rate of heat release, max	kW/m ²	0.11	1.3	
Heat released, 10 min	MJ/m ²	0.16	1.3	2.0
SMOKE release rate, max	SMOKE/min, m ²	0.31	4.5	6.8
SMOKE released, 10 min	SMOKE/m ²	0.23	15.	22.

16.5 For materials or products that burn from a non-uniform surface due to warping, slumping, or melting, single laboratory standard deviation values for heat and smoke release may be 50 % greater than those described in 16.3. For such samples, at least five specimens shall be tested. If two or more test values are greater by more than 50 % of the standard deviation values (see 16.3), the test conditions or sample shall be judged inappropriate for testing by this test method.

16.6 For materials whose self-propagating flux is greater than 0.0, repeatability of tests conducted at an incident flux

close to (for example, ± 3 kW/m²) the specimen's self-propagating flux may be poor because small differences in operating conditions may result in a large change in release rates.

17. Keywords

17.1 calorimetry; ignitability; heat release; smoke obscuration; smoke release

APPENDIXES

(Nonmandatory Information)

X1. RELEASE RATE TESTS

X1.1 This test procedure was designed for ease of operation and rapid turn-around time. Four to ten tests per hour at the same exposure conditions can be readily performed by a skilled operator.

X1.2 Because of the large amount of data available from

one release rate test, it is very desirable to use a computer for data acquisition and reduction.

X1.3 Research reports were prepared describing development of this release rate test and application of data obtained.¹³

X2. RELEASE RATE CALIBRATION

X2.1 The calibration data for heat release rate shows a linear relationship between rate of heat release and millivolt output from the thermopile compensator thermocouples up to the recommended maximum of 8 kW. At heat release rates over 10 kW produced by a gas flame from a vertical 11.2-mm tube (not the calibration burner), flames can be seen above the chimney. Above this level of heat release, thermocouple output is no longer proportional to rate of gas flow. While flame height is lower for flames from a more diffuse source such as from a specimen or the calibration burner, the recommended upper limit of heat release is 8 kW.

X2.2 Methane is a convenient fuel for calibrating the apparatus for rate of heat release. Flow rates and therefore rates of heat release can be easily and accurately controlled for calibration. For this gas, complete combustion can be assumed when calibration is conducted with radiant panel off. Solid materials can also be used to check calibration in terms of total

heat release. Samples of polymethyl-methacrylate were burned and the cumulative heat release calculated from the area under the rate-of-heat-release versus time curve. When specimens of 58 g were burned, the total heat released from three determinations was: 1390, 1421, and 1290 kJ, giving an average heat release of 1367 kJ. Cumulative heat released per unit mass, based on the average, is 23.5 MJ/kg. The theoretical net heat of combustion for this material is 21.1 MJ/kg. Based on these numbers, the combustion efficiency is 93 %, a reasonable value for polymethyl methacrylate under normal burning conditions.

X2.3 A typical calibration curve of chart reading versus percent transmission for the smoke monitor (see 11.6) is shown in Fig. X2.1. Points shown were experimentally determined using neutral density filters (see 12.2). A smooth curve is drawn through the points, and values of optical density calculated from selected points on the percent transmission axis. Then a working curve of optical density versus chart reading is

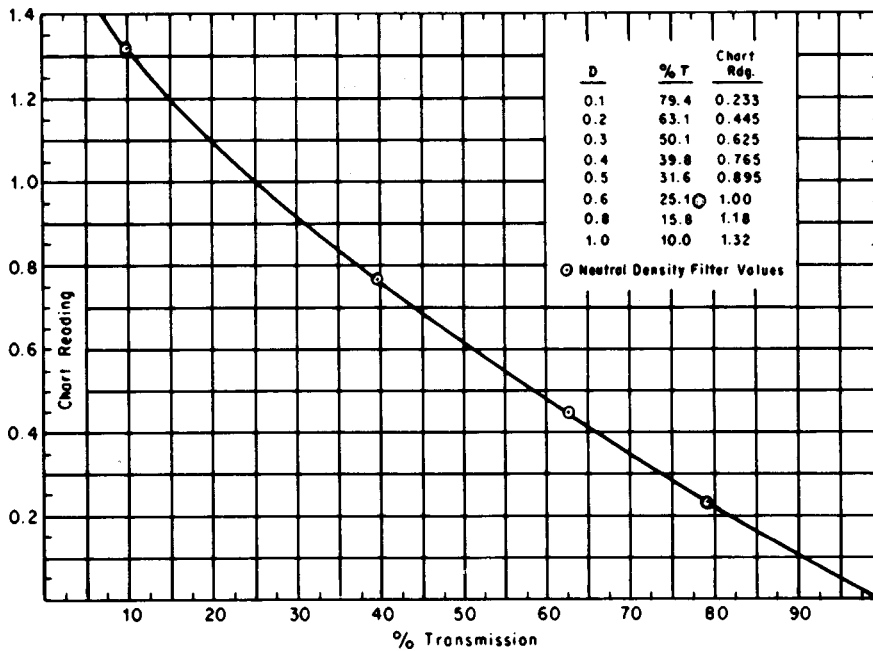

FIG. X2.1 Percent Transmission versus Chart Reading

prepared as shown in Fig. X2.2. If data reduction is computer assisted, the relationship shown in Fig. X1.2 may be converted to a calculation using a power series, as follows:

$$Y = Ax + Bx^2 + Cx^3 \quad (X2.1)$$

where:

- Y = optical density
- x = millimolt output, and
- $A, B,$ and C = constants.

X2.4 The smoke monitor requires a 10 to 15-min warm-up period to obtain a stable baseline. The condition of the detector

should then be checked by inserting the 0.4-optical density filter in the light path and, if necessary, adjust the current flow to the lamp to give the same output as given during calibration. Normally no adjustment is necessary.

X2.5 Temperature of the effluent gases from the stack has no significant effect on the adjustment of the smoke monitor. No parts of the monitor are in contact with the effluent gases, and the elements of the monitor closest to the chimney, which may be subjected to low level radiant heat from the plume, are cooled by the purge air used to keep smoke from entering the monitor's openings.

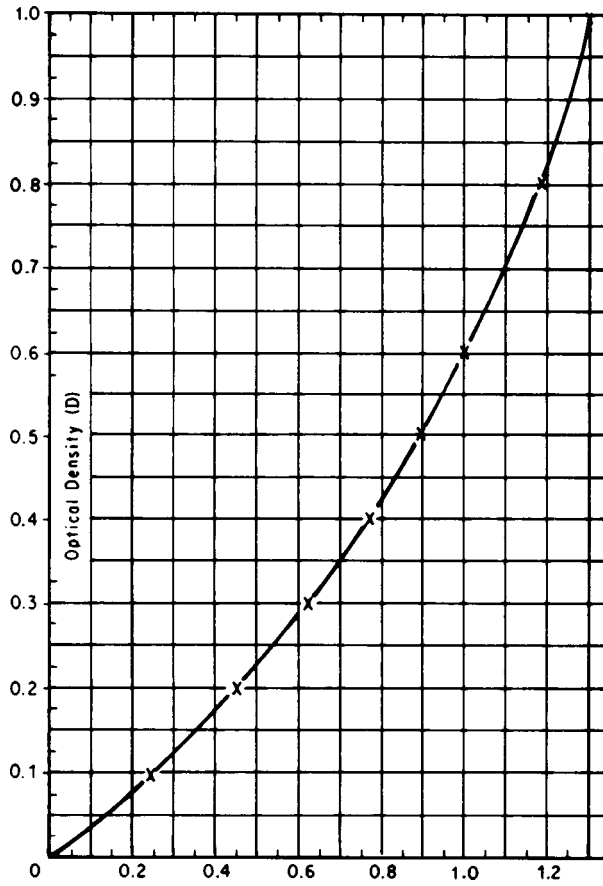

FIG. X2.2 Optical Density versus Chart Reading

X3. FLUX DISTRIBUTION

X3.1 The distribution of radiant heat flux across the specimen surface for both horizontal and vertical samples has been measured. Uniformity is achieved by the size and shape of the diamond-shaped mask (see 11.4 and Fig. 16), the bend on top and bottom of the reflector behind the silicon carbide heating elements (Fig. 16), and a properly matched set of heating elements. When properly adjusted, a maximum difference of less than 4 kW/m² is found over the area occupied by a 150 by 150-mm vertical specimen at 80 kW/m² incident flux. Non-uniformity of flux over the area occupied by horizontal specimens is less than 5 % of the average incident flux. Flux measurements over the vertical surface were made using a

plate with nine covered holes, slightly larger than the radiometer. The holes could be individually opened to admit and locate the radiometer at points corresponding to corners, center, and edge of the specimen surface. The plate fits over the opening covered by the radiation doors when closed. Flux measurements on a horizontal plane were made by placing the pyroheliometer (see 11.9) at different positions on the horizontal specimen holder with the radiometer's surface in the same plane a specimen surface would occupy. When checking the flux distribution, the 8-mm aluminum-foil shield as specified in 11.7.1 should be used on the front and back edge of the specimen holder.

X4. RADIATION REFLECTOR FOR HORIZONTAL SPECIMENS

X4.1 The best general purpose radiation reflector is that prepared from aluminum foil. Although it becomes coated with soot and, for some high heat release materials, melts during the course of a test, it provides a uniform, inexpensively renewable reflector that performs the task for which it was designed. The primary purpose of the reflector is to provide the desired incident flux to a horizontal specimen until the specimen is fire-involved. When a specimen burns at such a rate of heat and

smoke release that the quality of the reflector is impaired, the influence of external radiation on release rates is small; the specimen "sees" the radiation from its own flame, not the externally applied flux. The only portion of the release rate curve that may be influenced by the change in quality of the reflector is the cool-down portion when flaming decreases to zero, a comparatively unimportant period of a release rate test.

X5. COMMENTARY

X5.1 Release rate is not a “property” of a sample in the same sense as is calorific value, density, etc. Except for liquids (or solids that melt and burn as a liquid), release rates are not constant values even when all external variables are constant; they are often discontinuous functions of exposure and, in practice and theory, are influenced by numerous external variables. There is no one value that uniquely describes the heat release of most items. In general, a dynamic characteristic is not a property of a material but a reflection of external driving forces and internal resistances to these forces.

X5.2 Release rate data are obtained at a constant air flow rate and constant externally applied flux for a specific test. The incident, or externally applied, flux is that flux to the gas phase boundary generated by the specimen, *not* to the solid (or liquid) surface of the specimen.

X5.3 A release rate test is not designed to simulate an actual fire. While it is theoretically possible to predict a sample’s performance in a real fire given adequate release rate data, a single release rate test simply measures certain characteristics at one controlled external exposure. For this reason, a single characteristic measured during a release rate test (for example, maximum rate of heat release), taken by itself, may have little significance as a measure of general fire performance. Fire performance tests using conditions intended to simulate an actual fire usually determine the resultant of the individual characteristics that are measured by release rate tests. Therefore, use of release rate tests to describe performance in actual fires requires the judicious application of several characteristics over a range of exposure conditions. While measurement of individual fire performance characteristics make direct interpretation of release rate data more complex, such data provide the advantage of giving some insight into what specific characteristics of a sample need improvement to upgrade its overall fire performance.

X5.4 Using release rate tests, specimens can be examined at different exposure levels and their performance determined as a function of exposure level. This is a basically different approach to evaluating fire performance compared to the conventional performance tests. Using the conventional test, performance is determined at one set of exposure conditions and comparisons or ratings made on the basis of results at this test exposure. Extrapolation of data from single exposure tests is not advisable because performance does not change with temperature in the same way for different materials and products. Release rate tests provide a convenient means of getting information on performance at various exposure levels.

X5.5 Release rate of visible smoke obtained using this test method is calculated from the optical density of the effluent gas stream. Smoke release is expressed using an arbitrarily defined unit, SMOKE, (see 14.2.1). The SMOKE unit is used to give a quantitative description of visible smoke concentration, which is a direct function of optical density. By assuming an optical density value, for example, 0.82 (or 15 % Transmission) as limiting visibility, the maximum light path (l) for visibility can be calculated as follows:

$$l = D/kc \quad (X5.1)$$

where:

D = optical density,

k = absorption coefficient, (m^2/SMOKE) = $1.0 \text{ m}^2/\text{SMOKE}$, and

c = concentration, SMOKE/m^3 .

The visibility calculated in terms of l is based only on the optical properties of the smoke. The effect of eye irritants on visibility is not considered in this calculation.

X5.6 Reliable results are dependent upon obtaining reproducible specimens. Rate of heat release is sensitive to slight differences in surface characteristics as well as physical and chemical properties on a microas well as on a macro-scale.

ASTM International takes no position respecting the validity of any patent rights asserted in connection with any item mentioned in this standard. Users of this standard are expressly advised that determination of the validity of any such patent rights, and the risk of infringement of such rights, are entirely their own responsibility.

This standard is subject to revision at any time by the responsible technical committee and must be reviewed every five years and if not revised, either reapproved or withdrawn. Your comments are invited either for revision of this standard or for additional standards and should be addressed to ASTM International Headquarters. Your comments will receive careful consideration at a meeting of the responsible technical committee, which you may attend. If you feel that your comments have not received a fair hearing you should make your views known to the ASTM Committee on Standards, at the address shown below.

This standard is copyrighted by ASTM International, 100 Barr Harbor Drive, PO Box C700, West Conshohocken, PA 19428-2959, United States. Individual reprints (single or multiple copies) of this standard may be obtained by contacting ASTM at the above address or at 610-832-9585 (phone), 610-832-9555 (fax), or service@astm.org (e-mail); or through the ASTM website (www.astm.org).