



Standard Practice for Making and Curing Soil-Cement Compression and Flexure Test Specimens in the Laboratory¹

This standard is issued under the fixed designation D 1632; the number immediately following the designation indicates the year of original adoption or, in the case of revision, the year of last revision. A number in parentheses indicates the year of last reapproval. A superscript epsilon (ϵ) indicates an editorial change since the last revision or reapproval.

1. Scope

1.1 This practice covers the procedure for making and curing compression and flexure test specimens of soil-cement in the laboratory under accurate control of quantities of materials and test conditions.

1.2 *This standard may involve hazardous materials, operations, and equipment. This standard does not purport to address all of the safety concerns, if any, associated with its use. It is the responsibility of the user of this standard to establish appropriate safety and health practices and determine the applicability of regulatory limitations prior to use.*

2. Referenced Documents

2.1 ASTM Standards:

- C 127 Test Method for Specific Gravity and Absorption of Coarse Aggregate²
- D 558 Test Methods for Moisture-Density Relations of Soil-Cement Mixtures³
- D 559 Test Methods for Wetting-and-Drying Tests of Compacted Soil-Cement Mixtures³
- D 560 Test Methods for Freezing-and-Thawing Tests of Compacted Soil-Cement Mixtures³
- D 1633 Test Method for Compressive Strength of Molded Soil-Cement Cylinders³
- D 1634 Test Method for Compressive Strength of Soil-Cement Using Portions of Beams Broken in Flexure (Modified Cube Method)³
- D 1635 Test Method for Flexural Strength of Soil-Cement Using Simple Beam with Third-Point Loading³
- D 4753 Specification for Evaluating, Selecting, and Specifying Balances and Scales for Use in Testing Soil, Rock, and Related Construction Materials³
- E 11 Specification for Wire-Cloth Sieves for Testing Purposes⁴

3. Significance and Use

3.1 This practice is used to prepare soil-cement specimens for compressive and flexural strength testing in accordance with Method B of Test Method D 1633, Test Method D 1634, and Test Method D 1635.

3.2 This practice does not apply to soil-cement specimens prepared in commonly available molds, which are 4.0 in. (101.6 mm) in diameter and 4.584 in. (116.4 mm) in height. For these size specimens, Methods D 559 or Methods D 560 should be used for sample preparation. Compressive strength testing should be in accordance with Method A of Test Method D 1633.

4. Apparatus

4.1 *Compression Test Specimen Molds*—Molds (Fig. 1) having an inside diameter of 2.8 ± 0.01 in. (71 ± 0.25 mm) and a height of 9 in. (229 mm) for molding test specimens 2.8 in. (71 mm) in diameter and 5.6 in. (142 mm) high; machined steel top and bottom pistons having a diameter 0.005 in. (0.13 mm) less than the mold; a 6-in. (152-mm) long mold extension; and a spacer clip. At least two aluminum separating disks $\frac{1}{16}$ in. (1.54 mm) thick by 2.78 in. (70.6 mm) in diameter shall be provided.

NOTE 1—Satisfactory molds may be made from cold-drawn, seamless steel tubing having a Rockwell hardness of approximately 85 HRB or from steel pipe machined on the inside. The 2.8 by 5.6-in. (71 by 142-mm) specimens fit many triaxial compression machines in service, and thus may be used for triaxial as well as unconfined compression tests.

4.2 *Flexure Test Specimen Molds*—Molds having inside dimensions of 3 by 3 by $11\frac{1}{4}$ in. (76.2 by 76.2 by 285.8 mm) (see Fig. 2 and Fig. 3) for molding specimens of the same size. The molds shall be so designed that the specimen will be molded with its longitudinal axis in a horizontal position. The parts of the molds shall be tight-fitting and positively held together. The sides of the molds shall be sufficiently rigid to prevent spreading or warping. The interior faces of the molds shall be plane surfaces with a permissible variation, in any 3-in. (76.2-mm) line on a surface, of 0.002 in. (0.051 mm) for new molds and 0.003 in. (0.076 mm) for molds in use. The distance between opposite sides shall be 3 ± 0.01 in. (76.20 ± 0.25 mm) for new molds, and 3 ± 0.015 in. (76.20 ± 0.38 mm) for molds in use. The height of the molds shall be 3 in. (76.20 mm)

¹ This practice is under the jurisdiction of ASTM Committee D-18 on Soil and Rock and is the direct responsibility of Subcommittee D18.15 on Stabilization by Admixtures.

Current edition approved April 10, 1996. Published June 1996. Originally published as D 1632 – 59 T. Last previous edition D 1632 – 87.

² *Annual Book of ASTM Standards*, Vol 04.02.

³ *Annual Book of ASTM Standards*, Vol 04.08.

⁴ *Annual Book of ASTM Standards*, Vol 14.02.

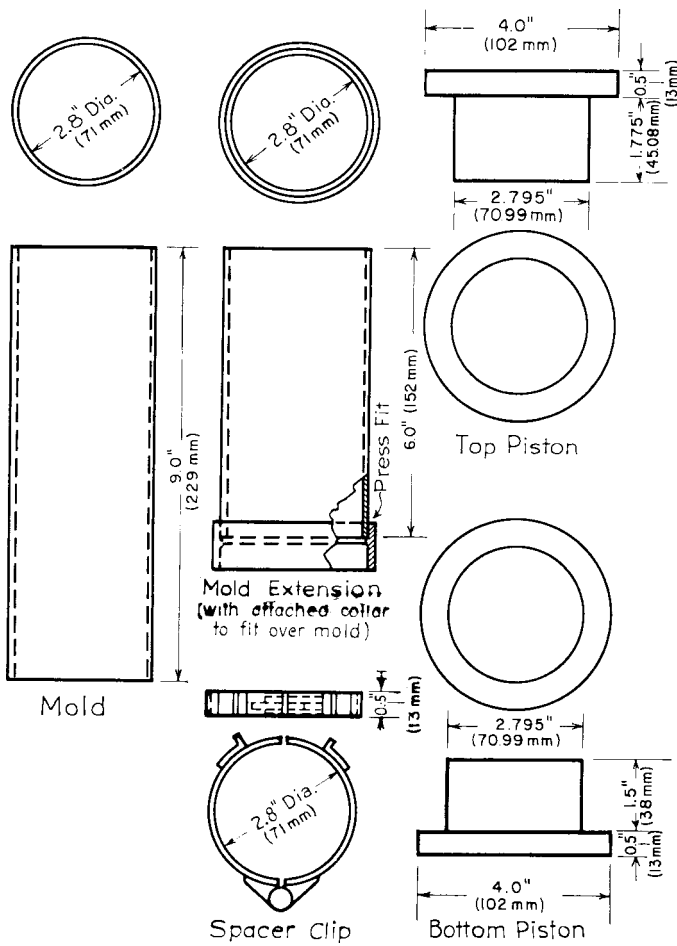

FIG. 1 Soil-Cement Cylinder Mold

with permissible variations of -0.01 in. (-0.25 mm) and $+0.005$ in. ($+0.13$ mm) for both new molds and for molds in use. Four $\frac{3}{8}$ -in. (9.52-mm) spacer bars and top and bottom machined steel plates shall be provided. The plates shall fit the mold with a 0.005-in. (0.13-mm) clearance on all sides.

NOTE 2—The molds shall be made of metal having a hardness not less than 85 HRB.

4.3 *Sieves*—2-in. (50-mm), $\frac{3}{4}$ -in. (19.0-mm), No. 4 (4.75-mm) and No. 16 (1.18-mm) sieves conforming to the requirements of Specification E 11.

4.4 *Balances*—A balance or scale of 25-lb (12-kg) capacity, sensitive to 0.01 lb (0.0045 kg) and a balance of 1000-g capacity, sensitive to 0.1 g, both meeting the requirements of Specification D 4753.

4.5 *Drying Oven*—A thermostatically controlled drying oven capable of maintaining a temperature of $230 \pm 9^\circ\text{F}$ ($110 \pm 5^\circ\text{C}$) for drying moisture samples.

4.6 *Compression Testing Machine or Compression Frame*, having a capacity of approximately 60 000 lbf (267 kN) for compacting flexural test specimens and for optional use in compacting compression test specimens.

4.7 *Dropping-Weight Compacting Machine*—A controlled dropping-weight device of 15 lb (6.8 kg) for striking the top piston, for optional use in compacting compression test specimens (see Fig. 4 and Fig. 5). When this equipment is used, the

top piston listed in 4.1 is made the foot of the compacting device.

4.8 *Compression Specimen Extruder*, consisting of a piston, jack, and frame for extruding specimens from the mold.

4.9 *Miscellaneous Equipment*—Tools such as trowel, spatula, pan, and the like, or a suitable mechanical device for thoroughly mixing the sample of soil-cement with water; graduate for measuring water, moisture sample cans, and the like.

4.10 *Tamping Rod*—A square-end cut, $\frac{1}{2}$ -in. (12.7-mm) diameter, smooth steel rod approximately 20 in. (510 mm) in length.

4.11 *Moist Room or Cabinet*—A moist room or cabinet capable of maintaining a temperature of $73.4 \pm 3^\circ\text{F}$ ($23.0 \pm 1.7^\circ\text{C}$) and a relative humidity of not less than 96 % for moist curing specimens.

5. Preparation of Materials

5.1 Bring materials to room temperature (preferably 65 to 75°F (18 to 24°C)) before beginning the tests.

5.2 Store cement in a dry place, in moisture-proof containers, preferably made of metal. Thoroughly mix the cement in order that the sample may be uniform throughout the tests. Pass it through a No. 16 (1.18-mm) sieve and reject all lumps.

5.3 The mixing water shall be free of acids, alkalies, and oils, and in general suitable for drinking.

5.4 Dry the soil sample, if damp when received from the field, until it becomes friable under a trowel. Drying may be in air or by use of drying apparatus such that the temperature of the sample does not exceed 140°F (60°C). Thoroughly break up the aggregations in such a manner as to avoid reducing the natural size of individual particles.

5.5 Sieve an adequate quantity of representative pulverized soil on the 2-in. (50-mm), $\frac{3}{4}$ -in. (19.0-mm), and No. 4 (4.75-mm) sieves. Discard any aggregate retained on the 2-in. (50-mm) sieve. Remove aggregate passing the 2-in. (50-mm) sieve and retained on the $\frac{3}{4}$ -in. (19.0-mm) sieve, and replace it with an equal mass of aggregate passing the $\frac{3}{4}$ -in. (19.0-mm) sieve and retained on the No. 4 (4.75-mm) sieve. Obtain aggregate for replacement from the original sample.

NOTE 3—This practice for making soil-cement specimens for compression and flexure tests is used primarily with soil materials having not more than 35 % aggregate retained on the No. 4 (4.75-mm) sieve and not more than 85 % retained on the No. 40 (425- μm) sieve.

5.6 Soak the aggregate passing the $\frac{3}{4}$ -in. sieve and retained on the No. 4 sieve in water for 24 h, remove, and surface dry. Determine the absorption properties in accordance with Test Method C 127.

5.7 Take a 100-g sample of the soil passing the No. 4 sieve and dry it in the drying oven to constant mass, and determine the water content of the sample to permit calculation of the quantity of water that shall be added to the soil-cement mixture to bring it to the proper water content for molding specimens.

5.8 Take a representative sample of sufficient size to make one flexure test specimen or three compression test specimens of the soil passing the No. 4 (4.75-mm) sieve and also of the fractions passing the $\frac{3}{4}$ -in. (19.0-mm) sieve and retained on the No. 4 (4.75 mm) sieve, prepared as described in 5.4, 5.5, and 5.6.

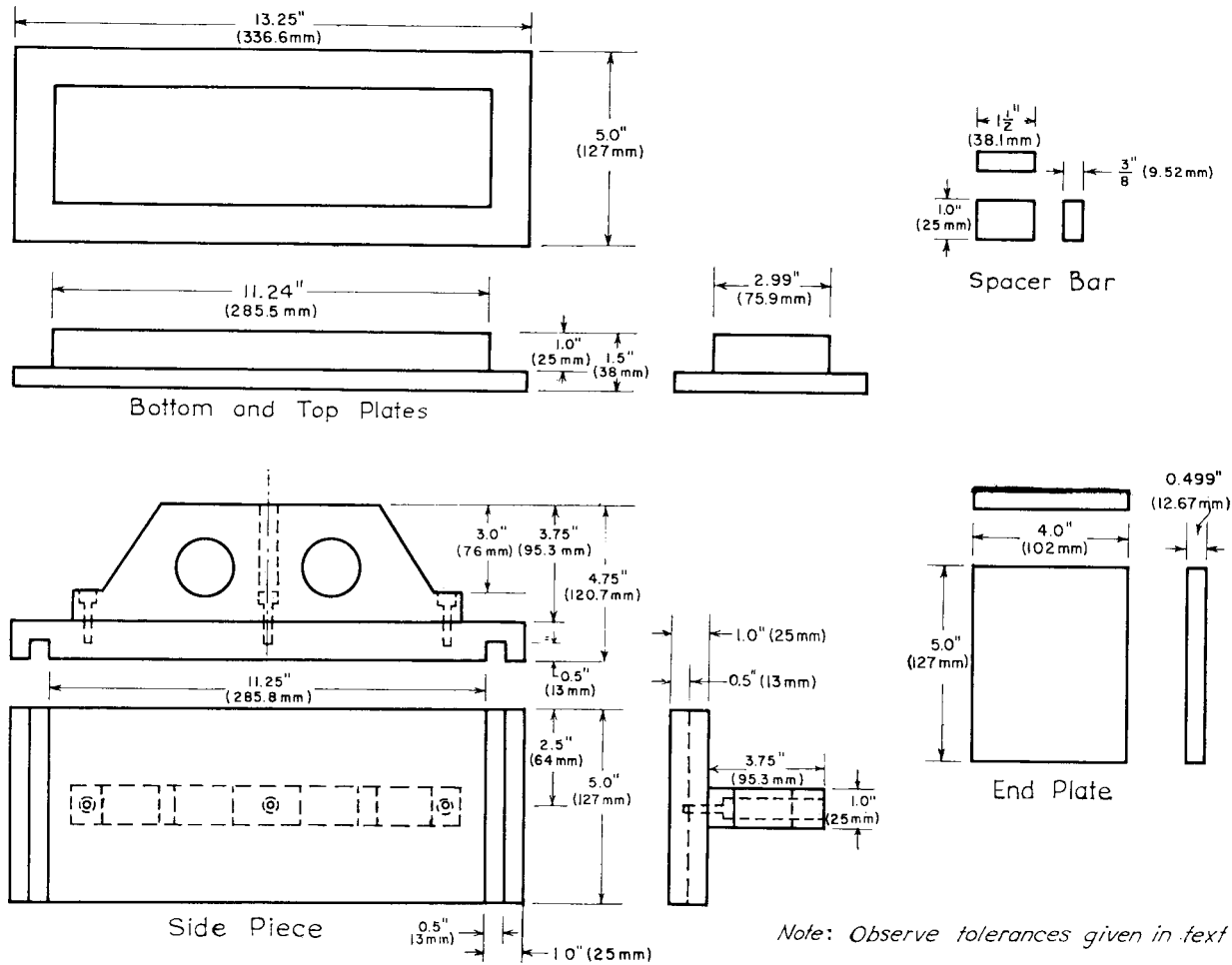

FIG. 2 Mold for Soil-Cement Beam for Flexure Test

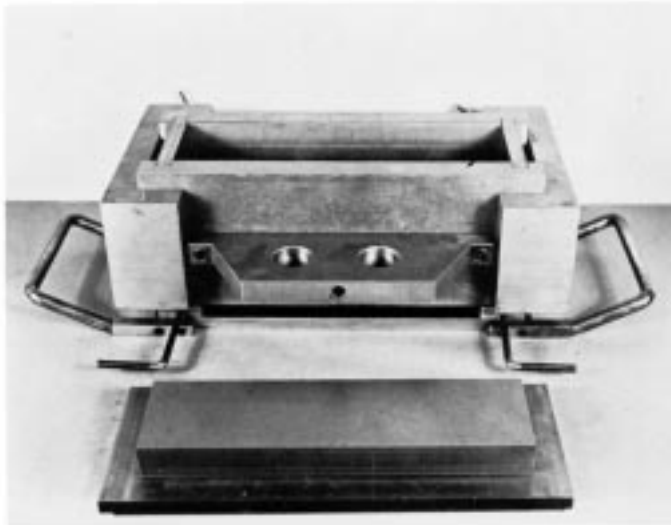

FIG. 3 Heavy Steel Mold and Top Plate for Making 3 by 3 by 11 1/4-in. (76.2 by 76.2 by 285.8-mm) Flexure Test Beam

6. Determining the Mass of Materials

6.1 Determine the mass to the nearest 0.01 lb (5 g) the designed quantities of soil passing the No. 4 (4.75-mm) sieve

and aggregate passing the 3/4-in. (19.0-mm) sieve and retained on the No. 4 sieve. Determine the mass to the nearest 1 g of the designed quantity of cement and measure the designed quantity of water to the nearest 1 mL.

NOTE 4—The designed quantities of soil, cement, and water are usually based on results obtained from ASTM tests. The “optimum” water content of the mixture and the “maximum” unit weight to which the specimens are compacted are determined by Test Methods D 558. The quantity of cement is usually sufficient to produce soil-cement of a quality suitable for road and runway base construction. This cement quantity is indicated by criteria established for interpreting the results obtained from Methods D 559 and Methods D 560.

7. Mixing Materials

7.1 General—Mix soil-cement either by hand or in a suitable laboratory mixer in batches of such size as to leave about 10% excess after molding test specimens. Protect this material against loss of water, determine the mass of a representative part of it and dry it in the drying oven to constant mass to determine the actual water content of the soil-cement mixture. When the soil-cement mixture contains aggregate retained on the No. 4 (4.75-mm) sieve, the sample for water content determination shall have a mass of at least 500 g and its mass shall be determined to the nearest gram. If the mixture does not contain aggregate retained on the No. 4 sieve, the sample shall have a mass of at least 100 g and its mass shall be

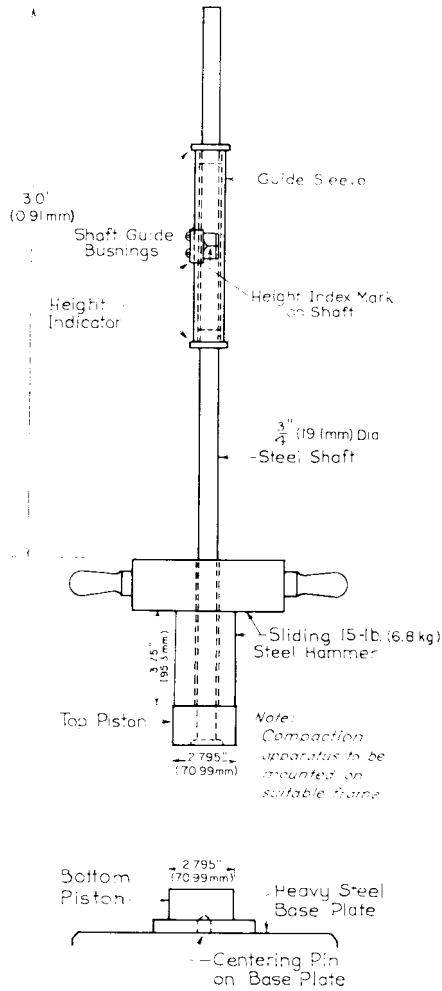

FIG. 4 Schematic Drawing of a Suitable Dropping-Weight Compacting Device

determined to the nearest 0.1 g.

7.2 *Hand Mixing*—Mix the batch in a clean, damp, metal pan or on top of a steel table, with a blunt bricklayer’s trowel, using the following procedure:

7.2.1 Mix the cement and minus No. 4 (4.75-mm) soil until they are thoroughly blended.

7.2.2 Add water and mix the mass until it is thoroughly blended.

7.2.3 Add the saturated surface-dry coarse aggregate and mix the entire batch until the coarse aggregate is uniformly distributed throughout the batch.

7.3 *Machine Mixing*—Follow the sequence specified for hand mixing. To eliminate segregation, deposit machine-mixed soil-cement in a clean, damp, metal pan and remix with the trowel.

NOTE 5—The operation of mixing and compacting compression and flexure test specimens shall be continuous and the elapsed time between the addition of water and final compaction shall not exceed 30 min.

COMPRESSION TEST SPECIMENS

8. Size of Specimens

8.1 Compression test specimens shall be cylinders with a length equal to twice the diameter. This method provides for

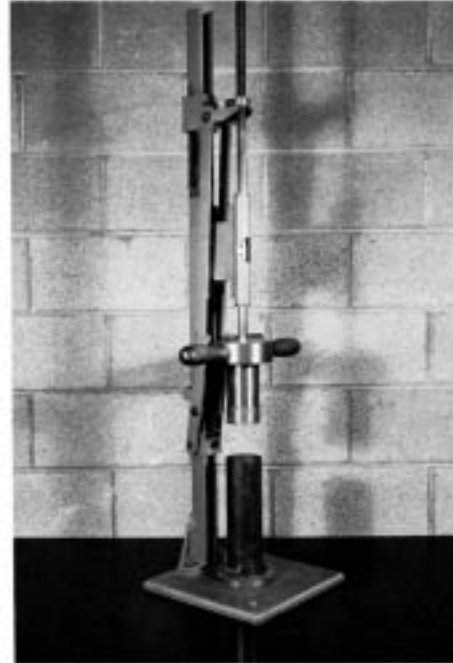

FIG. 5 Compacting Device Suitable for Making 2.8 by 5.6-in. (71 by 142 mm) Compression Test Cylinder

specimens 2.8 in. (71 mm) in diameter by 5.6 in. (142 mm) in length, but the same procedure may be used for molding larger or smaller specimens.

9. Molding Specimens

9.1 Lightly coat the mold and the two separating disks with commercial form oil. Hold the cylinder mold in place with the spacer clip over the bottom piston so that the latter extends about 1 in. (25 mm) into the cylinder.

9.2 Place a separating disk on top of the bottom piston and place the extension sleeve on top of the mold. Place in the mold a predetermined mass of the uniformly mixed soil-cement to provide a specimen of the designed unit weight when 5.6 in. (142 mm) high. When the soil-cement contains aggregate retained on the No. 4 (4.75-mm) sieve, carefully spade the mix around the mold sides with a thin spatula. Then compact the soil-cement initially from the bottom up by steadily and firmly forcing (with little impact) a square-end cut 1/2-in. (12.7-mm) diameter smooth steel rod repeatedly through the mixture from the top down to the point of refusal, distributing the roddings uniformly over the cross-section of the mold. Perform the operation carefully so as not to leave holes in clayey soil-cement mixtures. Repeat the process until the mass is packed out to a height of approximately 6 in. (150 mm).

9.3 Remove the extension sleeve and place a separating disk on the surface of the soil-cement. Remove the spacer clip supporting the mold on the bottom piston. Put the top piston in place and apply either a static load by the compression machine or a dynamic load by the compacting device until the specimen is 5.6 in. (142 mm) high.

9.4 Remove the pistons and separating disks from the mold assembly, but leave the specimen in the mold.

10. Curing Specimens

10.1 Cure the specimens in the molds in the moist room for 12 h, or longer if required, to permit subsequent removal from the molds using the sample extruder. Return the specimens to the moist room, but protect from dripping water for the specified moist curing period. Generally the specimens will be tested in the moist condition directly after removal from the moist room.

NOTE 6—Other conditioning procedures, such as soaking in water, air drying or oven drying, alternate wetting and drying, or alternate freezing and thawing, may be specified after an initial moist curing period. Curing and conditioning procedures shall be given in detail in the report.

11. Capping Specimens

11.1 Before testing, cap the ends of all compression specimens that are not plane within 0.002 in. (0.05 mm). Capped surfaces shall meet this same tolerance and shall be at right angles to the axis of the specimen.

11.2 Cap the specimens with gypsum plaster. The caps shall be as thin as practical and shall be aged sufficiently so that they will not flow or fracture when the specimen is tested (suggested time 3 h at 73°F (23°C)). During this period maintain the specimens at constant water content.

FLEXURE TEST SPECIMENS

12. Size of Specimen

12.1 Flexure test specimens shall be rectangular beams with a length as tested at least 2 in. (51 mm) greater than three times the depth. This procedure provides for beams 3 by 3 by 11¼ in. (76.2 by 76.2 by 285.8 mm), but the same procedures may be used for molding smaller or larger specimens.

13. Molding Specimens

13.1 Form the test specimens with the longitudinal axis horizontal. Lightly oil the mold parts and assemble with the sides and ends separated from the base plate by the ⅜-in. (9.53-mm) spacer bars, one placed at each corner of the mold.

13.2 Divide into three equal batches a predetermined mass of uniformly mixed soil-cement to make a beam of the designed unit weight. Place one batch of the material in the mold and level by hand. When the soil-cement contains aggregate retained on the No. 4 (4.75-mm) sieve, carefully spade the mix around the sides of the mold with a thin spatula. Compact the soil-cement initially from the bottom up by steadily and firmly, forcing (with little impact) a square-end cut ½-in. (12.7-mm) diameter smooth steel rod repeatedly through the mixture from the top down to the point of refusal. Approximately 90 roddings distributed uniformly over the cross section of the mold are required; take care so as not to leave holes in clayey soil-cement mixtures. Level this layer of compacted soil-cement by hand and place and compact layers two and three in an identical manner. The specimen at this time shall be approximately 3¾ in. (95 mm) high.

13.3 Place the top plate of the mold in position and remove the spacer bars. Obtain final compaction with a static load applied by the compression machine or compression frame until the designed height of 3.0 in. (76 mm) is reached.

13.4 Immediately after compaction, carefully dismantle the mold and remove the specimen onto a smooth, rigid, wood or sheet metal pallet.

NOTE 7—A suggested method for removing the specimen from the mold is to remove first the top and then the sides and end plates of the mold. The specimen is then resting on the bottom plate of the mold. The flat face of a carrying pallet is then placed against one side of the specimen and then the bottom mold plate, the specimen, and the pallet are rotated 90° so that the specimen rests on its side on the pallet. The bottom mold plate is then carefully removed.

14. Curing Specimens

14.1 Cure the specimens on pallets in the moist room and protect from free water for the specified moist curing period. Generally the specimen will be tested in the moist condition directly after removal from the moist room (see Note 6).

15. Capping Specimens

15.1 Before testing, cap areas, on opposite *sides* of the specimens as molded, that will come in contact with the load-applying block and supports and that are not plane within 0.002 in. (0.05 mm). Capped surfaces shall meet this same tolerance and shall be parallel to the horizontal axis of the specimen.

NOTE 8—Specimens are tested on their sides, with the original top and bottom surfaces as molded perpendicular to the testing machine bed. Specimens made in molds meeting the specifications in 3.2 generally will not require capping.

15.2 If capping is necessary, cap specimens with gypsum plaster. The caps shall be as thin as practical and shall be aged sufficiently so that they will not flow or fracture when the specimen is tested (suggested time 3 h at 73°F (23°C)). During this period maintain the specimens at constant water content.

REPORT

16. Report

16.1 The report shall include the following:

- 16.1.1 Gradation of soil as received and as used in making specimens,
- 16.1.2 Specimen identification number,
- 16.1.3 Designed water content,
- 16.1.4 Designed oven-dry unit weight,
- 16.1.5 Designed cement content,
- 16.1.6 Actual water content,
- 16.1.7 Actual oven-dry unit weight,
- 16.1.8 Actual cement content, and
- 16.1.9 Details of curing and conditioning periods.

17. Precision and Bias

17.1 This practice describes procedures for making and curing test specimens. Since there are no test values determined, a statement on precision and bias of the method is not applicable.

18. Keywords

18.1 flexural strength; soil-cement; soil stabilization; unconfined compressive strength



D 1632

ASTM International takes no position respecting the validity of any patent rights asserted in connection with any item mentioned in this standard. Users of this standard are expressly advised that determination of the validity of any such patent rights, and the risk of infringement of such rights, are entirely their own responsibility.

This standard is subject to revision at any time by the responsible technical committee and must be reviewed every five years and if not revised, either reapproved or withdrawn. Your comments are invited either for revision of this standard or for additional standards and should be addressed to ASTM International Headquarters. Your comments will receive careful consideration at a meeting of the responsible technical committee, which you may attend. If you feel that your comments have not received a fair hearing you should make your views known to the ASTM Committee on Standards, at the address shown below.

This standard is copyrighted by ASTM International, 100 Barr Harbor Drive, PO Box C700, West Conshohocken, PA 19428-2959, United States. Individual reprints (single or multiple copies) of this standard may be obtained by contacting ASTM at the above address or at 610-832-9585 (phone), 610-832-9555 (fax), or service@astm.org (e-mail); or through the ASTM website (www.astm.org).