



Standard Test Method for Flexural Strength of Soil-Cement Using Simple Beam with Third-Point Loading¹

This standard is issued under the fixed designation D 1635; the number immediately following the designation indicates the year of original adoption or, in the case of revision, the year of last revision. A number in parentheses indicates the year of last reapproval. A superscript epsilon (ϵ) indicates an editorial change since the last revision or reapproval.

1. Scope *

1.1 This test method covers the determination of the flexural strength of soil-cement by the use of a simple beam with third-point loading.

NOTE 1—For methods of molding soil-cement specimens, see Practice D 1632.

1.2 *Units*—The values stated in SI units are to be regarded as standard. The values given in parentheses are mathematical conversions to inch-pound units, which are provided for information only and are not considered standard.

1.2.1 The converted inch-pound units use the gravitational system of units. In this system, the pound (lbf) represents a unit of force (weight), while the unit for mass is slugs. The converted slug unit is not given, unless dynamic ($F = ma$) calculations are involved.

1.3 *This standard does not purport to address all of the safety concerns, if any, associated with its use. It is the responsibility of the user of this standard to establish appropriate safety and health practices and determine the applicability of regulatory limitations prior to use.*

2. Referenced Documents

2.1 *ASTM Standards:*

D 653 Terminology Relating to Soil, Rock, and Contained Fluids²

D 1632 Practice for Making and Curing Soil-Cement Compression and Flexure Test Specimens in the Laboratory²

D 3740 Practice for the Minimum Requirements for Agencies Engaged in the Testing and/or Inspection of Soil and Rock as Used in Engineering Design and Construction²

E 4 Standard Practices for Force Verification of Testing Machines³

3. Terminology

3.1 *Definitions:*

3.1.1 For common definitions of terms in this standard, refer to Terminology D 653.

¹ This test method is under the jurisdiction of ASTM Committee D18 on Soil and Rock and is the direct responsibility of Subcommittee D18.15 on Stabilization by Admixtures.

Current edition approved June 10, 2000. Published September 2000. Originally published as D 1635 – 59 T. Last previous edition D 1635 – 95.

² *Annual Book of ASTM Standards*, Vol 04.08.

³ *Annual Book of ASTM Standards*, Vol 03.01.

4. Significance and Use

4.1 This test method is used to determine the flexural strength of soil-cement. Flexural strength is significant in pavement design and is used to determine slab thickness.

NOTE 2—The quality of the result produced by this standard is dependent on the competence of the personnel performing it, and the suitability of the equipment and facilities used. Agencies that meet the criteria of Practice D 3740 are generally considered capable of competent and objective testing/sampling/inspection/etc. Users of this standard are cautioned that compliance with Practice D 3740 does not in itself assure reliable results. Reliable results depend on many factors; Practice D 3740 provides a means of evaluating some of those factors.

5. Apparatus

5.1 *Testing Machine*—The testing machine may be of any type having sufficient capacity and control to provide the rate of loading (prescribed in 7.2). It shall conform to the requirements of Section 15 of Practices E 4. The testing machine shall be equipped with a spherically seated head block having a bearing surface of at least 75 % of the width of the beam but not greatly in excess of the width of the beam. The movable portion of this block shall be held closely in the spherical seat, but the design shall be such that the bearing face may be rotated freely and tilted through small angles in any direction.

5.2 The third-point loading method used in making flexure tests of soil-cement shall employ bearing blocks that will ensure that forces applied to the beam will be vertical only and applied without eccentricity. A diagrammatic drawing of an apparatus that accomplishes this purpose is shown in Fig. 1. The apparatus shall be designed to incorporate the following principles:

5.2.1 The distance between supports and points of load application shall remain constant for a given apparatus.

5.2.2 The direction of the reactions shall be parallel to the direction of the applied load at all times during the test.

5.2.3 The load shall be applied at a uniform rate and in such a manner as to avoid shock.

5.2.4 The directions of loads and reactions may be maintained parallel by judicious use of linkages, rocker bearings, and flexure plates. Eccentricity of loading can be avoided by use of spherical bearings.

6. Test Specimens

6.1 The standard test specimens shall be beams 76 by 76 by

*A Summary of Changes section appears at the end of this standard.

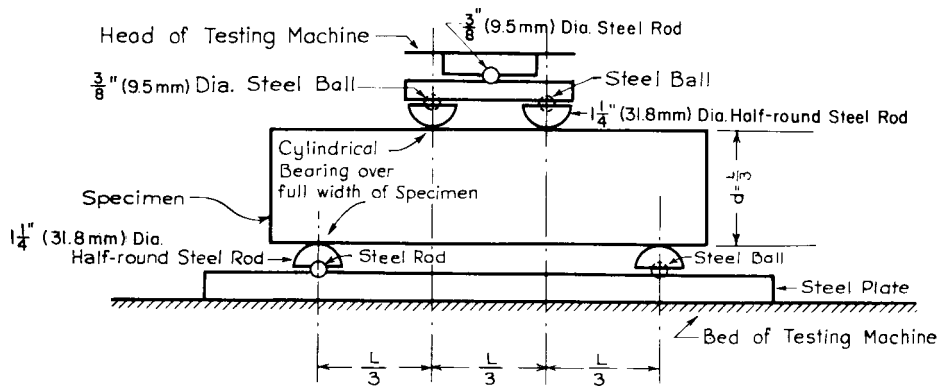

FIG. 1 Diagrammatic View of Apparatus for Flexure Test of Soil-Cement by Third-Point Loading Method

290 mm (3 by 3 by 11 1/4 in.), but a similar test method may be used for testing specimens of other sizes. Test the specimens on their sides with respect to their molded position.

6.2 Make flexural tests of moist cured specimens as soon as practicable after removing them from the moist room, and during the period between removal from the moist room and testing keep the specimens moist by a wet burlap or blanket covering.

NOTE 3—Other conditioning procedures, such as soaking in water, air or oven drying, alternate wetting and drying or alternate freezing and thawing, may be specified after an initial moist curing period. Curing and conditioning procedures shall be given in detail in the report.

6.3 Check the smoothness of the side faces of the beams at the points where loads will be applied with a straightedge. If necessary, cap the faces to meet the requirements of Section 15 of Practice D 1632.

7. Procedure

7.1 Turn the specimen on its side with respect to its molded position and center it on the lower half-round steel supports, which have been spaced apart a distance of three times the depth of the beam. Place the load-applying block assembly in contact with the upper surface of the beam at the third points between the supports. Carefully align the center of the beam with the center of thrust of the spherically seated head block of the machine. As this block is brought to bear on the beam-loading assembly, rotate its movable portion gently by hand so that uniform seating is obtained.

7.2 Apply the load continuously and without shock. A screw power testing machine, with the moving head operating at approximately 0.02 mm/s (0.05 in./min) when the machine is running idle, may be used. With hydraulic machines adjust the loading to such a constant rate that the extreme fiber stress is within the limits of 690 ± 39 kPa/min (100 ± 5 psi). Record the total load of failure of the specimen to the nearest 40 N (10 lbf).

8. Measurement of Specimens After Test

8.1 Make measurements to the nearest 0.25 mm (0.01 in.) to determine the average width and depth of the specimens at the section of failure.

9. Calculations

9.1 If the fracture occurs within the middle third of the span

TABLE 1 Precision

	Average flexural strength, psi	Standard deviation, psi	Coefficient of variation, %
Specimens with 6 % cement	94	6	6.4
Specimens with 14 % cement	157	9	5.7

length, calculate the modulus of rupture as follows:

$$R = PL/bd^2$$

where:

- R = modulus of rupture, kPa (psi),
- P = maximum applied load, N (lbf),
- l = span length, mm (in.),
- b = average width of specimen, mm (in.), and
- d = average depth of specimen, mm (in.).

NOTE 4—Mass of the beam is not included in the above calculation.

9.2 If the fracture occurs outside the middle third of the span length by not more than 5 % of the span length, calculate the modulus of rupture as follows:

$$R = 3Pa/bd^2$$

where:

- a = distance between line of fracture and the nearest support, measured along the center line of the bottom surface of the beam.

9.3 If the fracture occurs outside the middle third of the span by more than 5 % of the span length, discard the results of the test.

10. Report

- 10.1 The report shall include the following:
 - 10.1.1 Specimen identification number,
 - 10.1.2 Average width and depth at section of failure to the nearest 0.25 mm (0.01 in.),
 - 10.1.3 Maximum load, to the nearest 40 N (10 lbf),
 - 10.1.4 Modulus of rupture, calculated to the nearest 35 kPa (5 psi),
 - 10.1.5 Defects, if any, in specimen,
 - 10.1.6 Age of specimen, and
 - 10.1.7 Details of curing and conditioning periods, and water content at time of test.

11. Precision and Bias

11.1 *Precision*—The precision of this test method has not been established by an interlaboratory test program. However, based on test data that are available, the following may serve as a guide to the variability of flexural strength test results.

11.1.1 Tests were performed in a single lab on a silt loam soil with 92 % passing the No. 200 sieve. Liquid limit and plasticity index of soil were 26 and 7, respectively. The series of tests consisted of 24 specimens, 12 at 6 % cement, 12 at 14 % cement. The specimens were cured in a moist room at

23°C (73° F) for 28 days. Results⁴ of the tests are given in Table 1.

11.2 *Bias*—There is no accepted reference value for this test method, therefore, bias cannot be determined.

12. Keywords

12.1 flexural strength; soil-cement; soil stabilization

⁴ Felt, E. J., Abrams, M. S., *Strength and Elastic Properties of Compacted Soil-Cement Mixtures*, ASTM STP 206, ASTM, 1957.

SUMMARY OF CHANGES

In accordance with Committee D18 policy, this section identifies the location of changes to this standard since the last edition (95) that may impact the use of the standard.

- (1) Section 1 — Inserted as 1.2 statement on units and renumbered section 1.2 to 1.3.
- (2) Section 2.1 — Inserted references to D 653 and D 3740.
- (3) Section 2.1 — Updated title of E 4 reference.
- (4) New section 3 — Inserted new section 3 – Terminology with reference to D 653 for terms. Renumbered subsequent sections as needed.
- (5) Renumbered section 4 — Inserted as Note 2 standard

reference to D 3740 and renumbered remaining notes as needed.

- (6) Renumbered sections 6.1, 7.2, 8.1, 9.1, 10.1.2, 10.1.3, 10.1.4, and 11.1.1 and Fig. 1 — placed SI units first and places inch-pound units in parentheses.
- (7) Added Summary of Changes section.
- (8) Corrected headquarters address for ASTM

The American Society for Testing and Materials takes no position respecting the validity of any patent rights asserted in connection with any item mentioned in this standard. Users of this standard are expressly advised that determination of the validity of any such patent rights, and the risk of infringement of such rights, are entirely their own responsibility.

This standard is subject to revision at any time by the responsible technical committee and must be reviewed every five years and if not revised, either reapproved or withdrawn. Your comments are invited either for revision of this standard or for additional standards and should be addressed to ASTM Headquarters. Your comments will receive careful consideration at a meeting of the responsible technical committee, which you may attend. If you feel that your comments have not received a fair hearing you should make your views known to the ASTM Committee on Standards, at the address shown below.

This standard is copyrighted by ASTM, 100 Barr Harbor Drive, PO Box C700, West Conshohocken, PA 19428-2959, United States. Individual reprints (single or multiple copies) of this standard may be obtained by contacting ASTM at the above address or at 610-832-9585 (phone), 610-832-9555 (fax), or service@astm.org (e-mail); or through the ASTM website (www.astm.org).