



Standard Test Method for CBR (California Bearing Ratio) of Laboratory-Compacted Soils¹

This standard is issued under the fixed designation D 1883; the number immediately following the designation indicates the year of original adoption or, in the case of revision, the year of last revision. A number in parentheses indicates the year of last reapproval. A superscript epsilon (ϵ) indicates an editorial change since the last revision or reapproval.

This standard has been approved for use by agencies of the Department of Defense.

1. Scope *

1.1 This test method covers the determination of the CBR (California Bearing Ratio) of pavement subgrade, subbase, and base/course materials from laboratory compacted specimens. The test method is primarily intended for but not limited to, evaluating the strength of cohesive materials having maximum particle sizes less than $\frac{3}{4}$ in. (19 mm).

NOTE 1—The agency performing this test can be evaluated in accordance with Practice D 3740.

Notwithstanding statements on precision and bias contained in this Standard: The precision of this test method is dependent on the competence of the personnel performing it and the suitability of the equipment and facilities used. Agencies which meet the criteria of Practice D 3740 are generally considered capable of competent and objective testing. Users of this method are cautioned that compliance with Practice D 3740 does not in itself assure reliable testing. Reliable testing depends on many factors; Practice D 3740 provides a means of evaluating some of those factors.

1.2 When materials having maximum particle sizes greater than $\frac{3}{4}$ in. (19 mm) are to be tested, this test method provides for modifying the gradation of the material so that the material used for tests all passes the $\frac{3}{4}$ -in. sieve while the total gravel (+No. 4 to 3 in.) fraction remains the same. While traditionally this method of specimen preparation has been used to avoid the error inherent in testing materials containing large particles in the CBR test apparatus, the modified material may have significantly different strength properties than the original material. However, a large experience base has developed using this test method for materials for which the gradation has been modified, and satisfactory design methods are in use based on the results of tests using this procedure.

1.3 Past practice has shown that CBR results for those materials having substantial percentages of particles retained on the No. 4 sieve are more variable than for finer materials. Consequently, more trials may be required for these materials to establish a reliable CBR.

1.4 This test method provides for the determination of the CBR of a material at optimum water content or a range of water content from a specified compaction test and a specified dry unit weight. The dry unit weight is usually given as a percentage of maximum dry unit weight from the compaction tests of Test Methods D 698 or D 1557.

1.5 The agency requesting the test shall specify the water content or range of water content and the dry unit weight for which the CBR is desired.

1.6 Unless specified otherwise by the requesting agency, or unless it has been shown to have no effect on test results for the material being tested, all specimens shall be soaked prior to penetration.

1.7 For the determination of CBR of field compacted materials, see Test Method D 4429.

1.8 The values stated in inch-pound units are to be regarded as the standard. The SI equivalents shown in parentheses may be approximate.

1.9 *This standard does not purport to address all of the safety problems, if any, associated with its use. It is the responsibility of the user of this standard to establish appropriate safety and health practices and determine the applicability of regulatory limitations prior to use.*

2. Referenced Documents

2.1 ASTM Standards:

- D 422 Test Method for Particle-Size Analysis of Soils²
- D 653 Terminology Relating to Soil, Rock, and Contained Fluids²
- D 698 Test Method for Laboratory Compaction Characteristics of Soil Using Standard Effort (12,400 ft-lbf/ft³ (600 kN-m/m³))²
- D 1557 Test Method for Laboratory Compaction Characteristics of Soil Using Modified Effort (56,000 ft-lbf/ft³ (2,700 kN-m/m³))²
- D 2168 Test Methods for Calibration of Laboratory Mechanical-Rammer Soil Compactors²
- D 2216 Test Method for Laboratory Determination of Water (Moisture) Content of Soil and Rock²

¹ This test method is under the jurisdiction of ASTM Committee D-18 on Soil and Rock and is the direct responsibility of Subcommittee D18.08 on Special and Construction Control Tests.

Current edition approved Feb. 10, 1999. Published May 1999. Originally published as D 1883 – 61T. Last previous edition D 1883 – 94.

² Annual Book of ASTM Standards, Vol 04.08.

***A Summary of Changes section appears at the end of this standard.**

- D 2487 Classification of Soils for Engineering Purposes (Unified Soil Classification System)²
- D 2488 Practice for Description and Identification of Soils (Visual-Manual Procedure)²
- D 3740 Practice for Minimum Requirements of Agencies Engaged in the Testing and/or Inspection of Soil and Rock as Used in Engineering Design and Construction²
- D 4318 Test Method for Liquid Limit, Plastic Limit, and Plasticity Index of Soils²
- D 4429 Test Method for CBR (California Bearing Ratios) of Soils in Place²

3. Summary of Test Method

3.1 For tests performed on materials compacted to one water content, three specimens are prepared. The specimens are compacted using three different compactive efforts to obtain unit weights both above and below the desired unit weight. After allowing specimens to take on water by soaking, or other specified treatment such as curing, each specimen is subjected to penetration by a cylindrical rod. Results of stress (load) versus penetration depth are plotted to determine the CBR for each specimen. The CBR at the specified density is determined from a graph of CBR versus dry unit weight.

3.2 For tests in which the result is to be determined for a water content range, a series of specimens at each of three compactive efforts are prepared over the range of water content of interest. The compactive efforts are chosen to produce unit weights above and below the desired unit weight. After allowing the specimens to take on water by soaking, or other specified treatment such as curing, each specimen is penetrated. Results are plotted to obtain the CBR for each specimen. A plot of CBR versus unit weight for each water content is made to determine the minimum CBR for the water content range of interest.

4. Significance and Use

4.1 This test method is used to evaluate the potential strength of subgrade, subbase, and base course material, including recycled materials for use in road and airfield pavements. The CBR value obtained in this test forms an integral part of several flexible pavement design methods.

4.2 For applications where the effect of compaction water content on CBR is small, such as cohesionless, coarse-grained materials, or where an allowance is made for the effect of differing compaction water contents in the design procedure, the CBR may be determined at the optimum water content of a specified compaction effort. The dry unit weight specified is normally the minimum percent compaction allowed by the using agency's field compaction specification.

4.3 For applications where the effect of compaction water content on CBR is unknown or where it is desired to account for its effect, the CBR is determined for a range of water content, usually the range of water content permitted for field compaction by using agency's field compaction specification.

4.4 The criteria for test specimen preparation of self cementing (and other) materials which gain strength with time must be based on a geotechnical engineering evaluation. As directed by the engineer, self cementing materials shall be

properly cured until bearing ratios representing long term service conditions can be measured.

5. Apparatus

5.1 *Loading Machine*—The loading machine shall be equipped with a movable head or base that travels at a uniform (not pulsating) rate of 0.05 in. (1.27 mm)/min for use in forcing the penetration piston into the specimen. The machine shall be equipped with a load-indicating device that can be read to 10 lbf (44 N) or less. The minimum capacity of the loading machine shall be based on the requirements indicated in Table 1.

5.2 *Mold*—The mold shall be a rigid metal cylinder with an inside diameter of 6 ± 0.026 in. (152.4 ± 0.66 mm) and a height of 7 ± 0.018 in. (177.8 ± 0.46 mm). It shall be provided with a metal extension collar at least 2.0 in. (50.8 mm) in height and a metal base plate having at least twenty eight $\frac{1}{16}$ -in. (1.59-mm) diameter holes uniformly spaced over the plate within the inside circumference of the mold. When assembled with spacer disc in place in the bottom of the mold, the mold shall have an internal volume (excluding extension collar) of 0.075 ± 0.0009 ft (2124 ± 25 cm). Fig. 1 shows a satisfactory mold design. A calibration procedure should be used to confirm the actual volume of the mold with the spacer disk inserted. Suitable calibrations are contained in Test Methods D 698 and D 1557.

5.3 *Spacer Disk*—A circular metal spacer disc (see Fig. 1) having a minimum outside diameter of $5\frac{1}{16}$ in. (150.8 mm) but no greater than will allow the spacer to easily slip into the mold. The spacer disc shall be 2.416 ± 0.005 in. (61.37 ± 0.127 mm) in height.

5.4 *Rammer*—A rammer as specified in either Test Methods D 698 or D 1557 except that if a mechanical rammer is used it must be equipped with a circular foot, and when so equipped, must provide a means for distributing the rammer blows uniformly over the surface of the soil when compacting in a 6-in. (152.4-mm) diameter mold. The mechanical rammer must be calibrated and adjusted in accordance with Test Methods D 2168.

5.5 *Expansion-Measuring Apparatus*—An adjustable metal stem and perforated metal plate, similar in configuration to that shown in Fig. 1. The perforated plate shall be $5\frac{7}{8}$ to $5\frac{1}{2}$ in. (149.23 to 150.81 mm) in diameter and have at least forty-two $\frac{1}{16}$ -in. (1.59-mm) diameter holes uniformly spaced over the plate. A metal tripod to support the dial gage for measuring the amount of swell during soaking is also required.

5.6 *Weights*—One or two annular metal weights having a total mass of 4.54 ± 0.02 kg and slotted metal weights each having masses of 2.27 ± 0.02 kg. The annular weight shall be $5\frac{7}{8}$ to $5\frac{1}{2}$ in. (149.23 to 150.81 mm) in diameter and shall have a center hole of approximately $2\frac{1}{8}$ in. (53.98 mm).

TABLE 1 Minimum Load Capacity

Maximum Measurable CBR	Minimum Load Capacity	
	(lbf)	(kN)
20	2500	11.2
50	5000	22.3
>50	10 000	44.5

TABLE 2 Metric Equivalents

Inch-Pound Units, in.	Metric Equivalent, mm	Inch-Pound Units, in.	Metric Equivalent, mm	Inch-Pound Units, in.	Metric Equivalent, mm
0.003	0.076	19/32	15.08	3 1/2	88.90
0.005	0.127	5/8	15.88	3 3/4	95.25
0.135	3.43	3/4	19.10	4 1/4	108.0
0.201	5.11	19/16	23.81	4 1/2	114.3
0.4375	11.11	1	25.40	4 3/4	120.7
0.4378	11.12	1 1/8	28.58	5 7/8	149.2
0.510	12.95	1 1/4	31.8	5 15/16	150.8
0.633	16.08	1 3/8	34.9	6	152.0
1.370	34.60	1 1/2	38.10	6 7/32	158.0
1.375	34.93	1 3/4	44.5	6 1/2	165.1
1.954	49.63	1 13/16	46.04	7	177.8
2.416	61.37	1 15/16	49.21	7 1/2	190.1
1/16	1.59	2	50.80	8 3/8	212.7
7/32	5.56	2 1/8	53.98	8 1/2	215.9
1/4	6.35	2 1/5	55.9	9 3/8	238.1
3/8	9.53	2 1/4	57.2	14 1/4	362.0
7/16	11.11	2 1/2	63.50	18	457.2
15/32	11.91	2 3/4	69.85	32 1/4	719.2
1/2	12.70	2 31/32	75.41	36 5/8	930.3
17/32	13.49	3	76.20	39	990.6

Inch-Pound Units, lb	Metric Equivalent, kg	Inch-Pound Units, psi	Metric Equivalent, MPa
0.04	0.02	200	1.4
0.05	0.02	400	2.8
0.12	0.05	600	4.1
0.59	0.27	800	5.5
0.71	0.32	1000	6.9
0.75	0.34	1200	8.3
3.20	1.45	1400	9.7
5.00	2.27		
10.00	4.54		

5.7 *Penetration Piston*—A metal piston 1.954 ± 0.005 in. (49.63 ± 0.13 mm) in diameter and not less than 4 in. (101.6 mm) long (see Fig. 1). If, from an operational standpoint, it is advantageous to use a piston of greater length, the longer piston may be used.

5.8 *Gages*—Two dial gages reading to 0.001 in. (0.025 mm) with a range of 0.200 minimum.

5.9 *Miscellaneous Apparatus*—Other general apparatus such as a mixing bowl, straightedge, scales, soaking tank or pan, oven, fast filtering high wet strength filter paper, dishes, and 2-in., 3/4-in. and No. 4 sieves.

6. Sample

6.1 The sample shall be handled and specimen(s) for compaction shall be prepared in accordance with the procedures given in Test Methods D 698 or D 1557 for compaction in a 6-in. (152.4-mm) mold except as follows:

6.1.1 If all material passes a 3/4-in. (19-mm) sieve, the entire gradation shall be used for preparing specimens for compaction without modification. If there is material retained on the 3/4-in. (19-mm) sieve, the material retained on the 3/4-in. (19-mm) sieve shall be removed and replaced by an equal amount of material passing the 3/4-in. (19-mm) sieve and retained on the No. 4 sieve obtained by separation from portions of the sample not otherwise used for testing.

7. Test Specimens

7.1 *Bearing Ratio at Optimum Water Content Only*—Using material prepared as described in 6.1, conduct a control

compaction test with a sufficient number of test specimens to definitely establish the optimum water content for the soil using the compaction method specified, either Test Methods D 698 or D 1557. A previously performed compaction test on the same material may be substituted for the compaction test just described, provided that if the sample contains material retained on the 3/4-in. (19-mm) sieve, soil prepared as described in 6.1 is used (Note 1).

NOTE 2—Maximum dry unit weight obtained from a compaction test performed in a 4-in. (101.6-mm) diameter mold may be slightly greater than the maximum dry unit weight obtained from compaction in the 6-in. (152.4-mm) compaction mold or CBR mold.

7.1.1 For cases where the CBR is desired at 100 % maximum dry unit weight and optimum water content, compact a specimen using the specified compaction procedure, either Test Methods D 698 or D 1557, from soil prepared to within ±0.5 percentage point of optimum water content in accordance with Test Method D 2216.

NOTE 3—Where the maximum dry unit weight was determined from compaction in the 4-in. (101.6-mm) mold, it may be necessary to compact specimens as described in 7.1.2, using 75 blows per layer or some other value sufficient to produce a specimen having a density equal to or greater than that required.

7.1.2 Where the CBR is desired at optimum water content and some percentage of maximum dry unit weight, compact three specimens from soil prepared to within ±0.5 percentage point of optimum water content and using the specified compaction but using a different number of blows per layer for

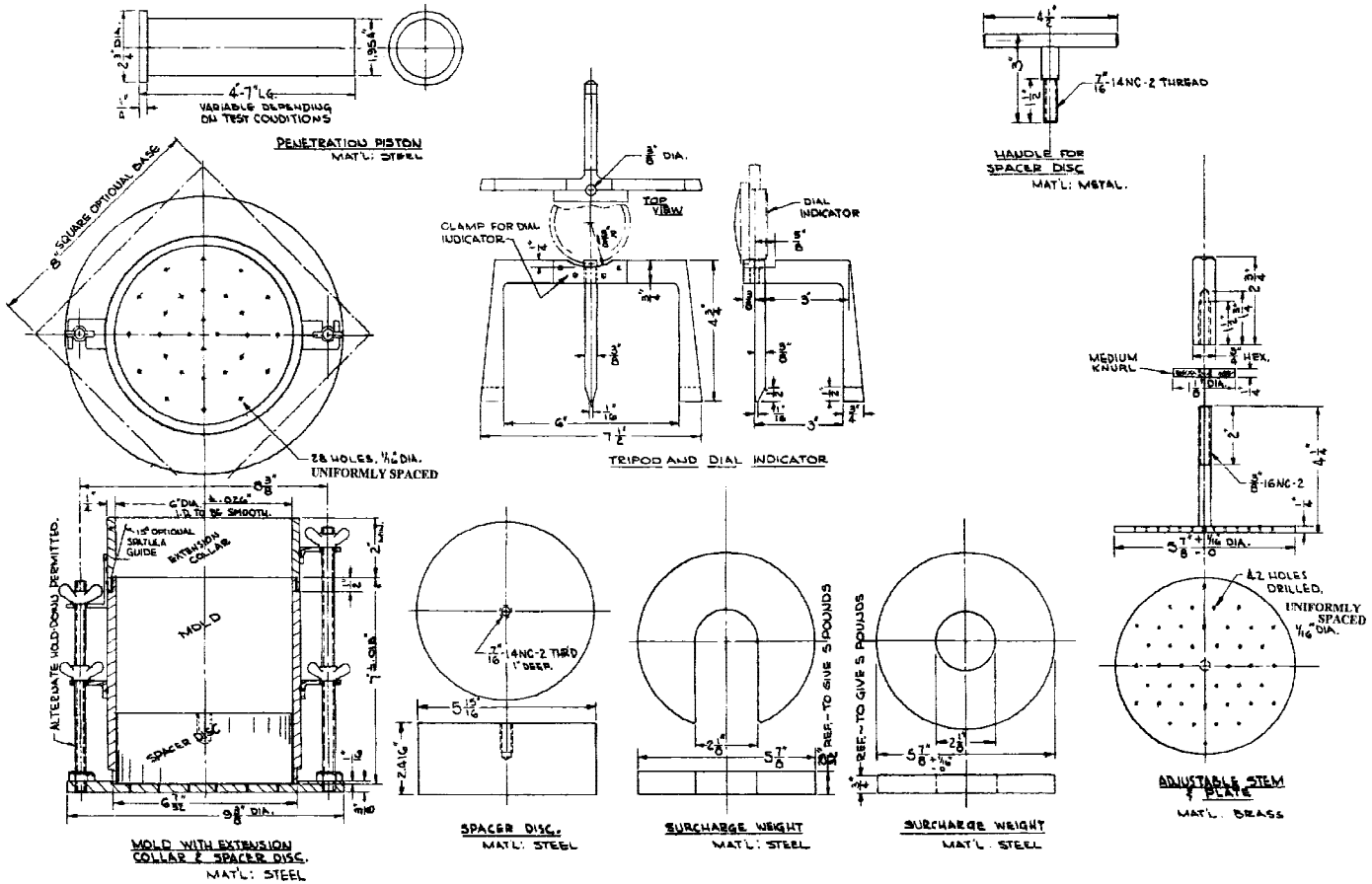

NOTE 1—See Table 2 for metric equivalents.
FIG. 1 Bearing Ratio Test Apparatus

each specimen. The number of blows per layer shall be varied as necessary to prepare specimens having unit weights above and below the desired value. Typically, if the CBR for soil at 95 % of maximum dry unit is desired, specimens compacted using 56, 25, and 10 blows per layer is satisfactory. Penetration shall be performed on each of these specimens.

7.2 *Bearing Ratio for a Range of Water Content*—Prepare specimens in a manner similar to that described in 7.1 except that each specimen used to develop the compaction curve shall be penetrated. In addition, the complete water content-unit weight relation for the 25-blow and 10-blow per layer compactations shall be developed and each test specimen compacted shall be penetrated. Perform all compaction in the CBR mold. In cases where the specified unit weight is at or near 100 % maximum dry unit weight, it will be necessary to include a compactive effort greater than 56-blows per layer (Note 3).

NOTE 4—A semilog log plot of dry unit weight versus compactive effort usually gives a straight line relation when compactive effort in ft-lb/ft³ is plotted on the log scale. This type of plot is useful in establishing the compactive effort and number of blows per layer needed to bracket the specified dry unit weight and water content range.

7.2.1 If the sample is to be soaked, take a representative sample of the material, for the determination of moisture, at the beginning of compaction and another sample of the remaining material after compaction. Use Test Method D 2216 to deter-

mine the moisture content. If the sample is not to be soaked, take a moisture content sample in accordance with Test Methods D 698 or D 1557 if the average moisture content is desired.

7.2.2 Clamp the mold (with extension collar attached) to the base plate with the hole for the extraction handle facing down. Insert the spacer disk over the base plate and place a disk of filter paper on top of the spacer disk. Compact the soil-water mixture into the mold in accordance with 7.1, 7.1.1, or 7.1.2.

7.2.3 Remove the extension collar and carefully trim the compacted soil even with the top of the mold by means of a straightedge. Patch with smaller size material any holes that may have developed in the surface by the removal of coarse material. Remove the perforated base plate and spacer disk, weigh, and record the mass of the mold plus compacted soil. Place a disk of coarse filter paper on the perforated base plate, invert the mold and compacted soil, and clamp the perforated base plate to the mold with compacted soil in contact with the filter paper.

7.2.4 Place the surcharge weights on the perforated plate and adjustable stem assembly and carefully lower onto the compacted soil specimen in the mold. Apply a surcharge equal to the weight of the base material and pavement within 2.27 kg (5 lb), but in no case shall the total weight used be less than 4.54 kg (10 lb). If no pavement weight is specified, use 4.54 kg.

Immerse the mold and weights in water allowing free access of water to the top and bottom of the specimen. Take initial measurements for swell and allow the specimen to soak for 96 h. Maintain a constant water level during this period. A shorter immersion period is permissible for fine grained soils or granular soils that take up moisture readily, if tests show that the shorter period does not affect the results. At the end of 96 h, take final swell measurements and calculate the swell as a percentage of the initial height of the specimen.

7.2.5 Remove the free water and allow the specimen to drain downward for 15 min. Take care not to disturb the surface of the specimen during the removal of the water. It may be necessary to tilt the specimen in order to remove the surface water. Remove the weights, perforated plate, and filter paper, and determine and record the mass.

8. Procedure for Bearing Test

8.1 Place a surcharge of weights on the specimen sufficient to produce an intensity of loading equal to the weight of the base material. If no pavement weight is specified, use 4.54 kg mass. If the specimen has been soaked previously, the surcharge shall be equal to that used during the soaking period. To prevent upheaval of soil into the hole of the surcharge weights, place the 2.27 kg annular weight on the soil surface prior to seating the penetration piston, after which place the remainder of the surcharge weights.

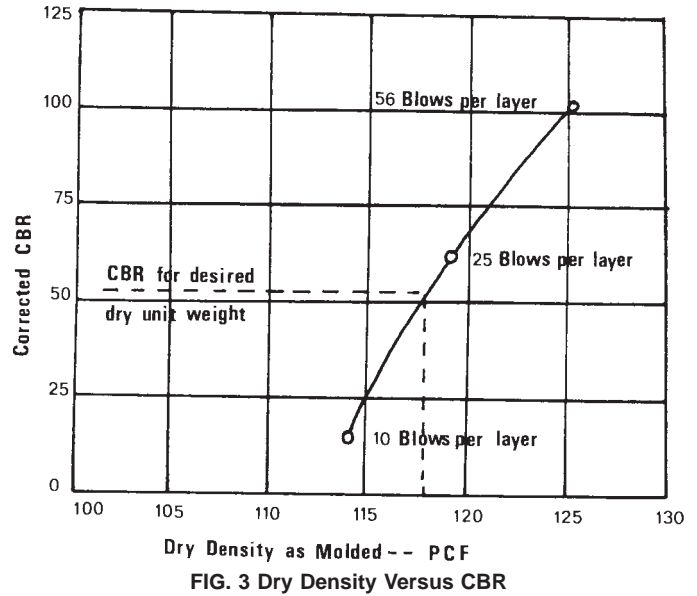

FIG. 3 Dry Density Versus CBR

to ensure satisfactory seating of the piston and shall be considered as the zero load when determining the load penetration relation. Anchor the strain gage to the load measuring device, if possible; in no case attach it to the testing machines support bars (legs).

NOTE 5—At high loads the supports may torque and affect the reading of the penetration gage. Checking the depth of piston penetration is one means of checking for erroneous strain indications.

8.3 Apply the load on the penetration piston so that the rate of penetration is approximately 0.05 in. (1.27 mm)/min. Record the load readings at penetrations of 0.025 in. (0.64 mm), 0.050 in. (1.27 mm), 0.075 in. (1.91 mm), 0.100 in. (2.54 mm), 0.125 in. (3.18 mm), 0.150 in. (3.81 mm), 0.175 in. (4.45 mm), 0.200 in. (5.08 mm), 0.300 in. (7.62 mm), 0.400 in. (10.16 mm) and 0.500 in. (12.70 mm). Note the maximum load and penetration if it occurs for a penetration of less than 0.500 in. (12.70 mm). With manually operated loading devices, it may be necessary to take load readings at closer intervals to control the rate of penetration. Measure the depth of piston penetration into the soil by putting a ruler into the indentation and measuring the difference from the top of the soil to the bottom of the indentation. If the depth does not closely match the depth of penetration gage, determine the cause and test a new sample.

8.4 Remove the soil from the mold and determine the moisture content of the top 1-in. (25.4-mm) layer. Take a moisture content sample in accordance with Test Methods D 698 or D 1557 if the average moisture content is desired. Each moisture content sample shall weigh not less than 100 g for fine-grained soils nor less than 500 g for granular soils.

NOTE 6—The load readings at penetrations of over 0.300 in. (7.6 mm) may be omitted if the testing machine's capacity has been reached.

9. Calculation

9.1 *Load-Penetration Curve*—Calculate the penetration stress in pounds per square inch or megapascals and plot the stress-penetration curve. In some instances, the stress-penetration curve may be concave upward initially, because of surface

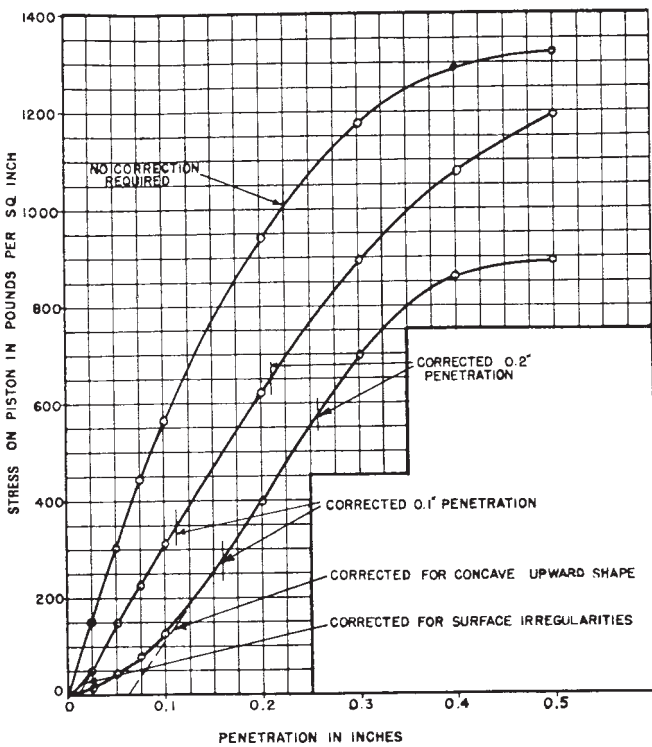

NOTE 1—See Table 2 for metric equivalents.

FIG. 2 Correction of Load-Penetration Curves

8.2 Seat the penetration piston with the smallest possible load, but in no case in excess of 10 lbf (44 N). Set both the stress and penetration gages to zero. This initial load is required

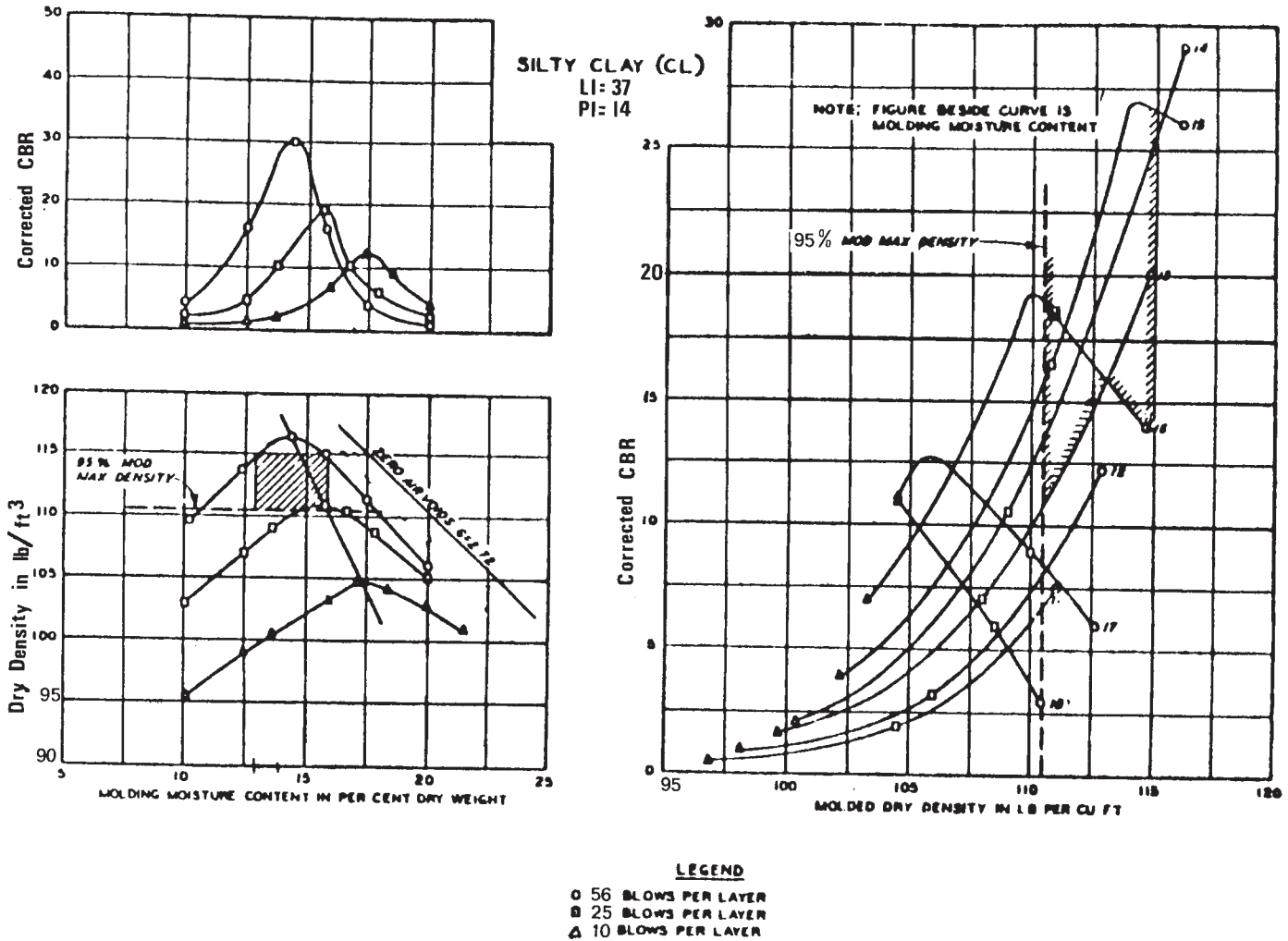

NOTE 1—Surcharge = 50 lb soaking and penetration. All samples soaked top and bottom four days. All samples compacted in 5 layers, 10-lb hammer, 18-in. drop in CBR mold.

FIG. 4 Determining CBR for Water Content Range and Minimum Dry Unit Weight

irregularities or other causes, and in such cases the zero point shall be adjusted as shown in Fig. 2.

NOTE 7—Fig. 2 should be used as an example of correction of load-penetration curves only. It is not meant to imply that the 0.2-in. penetration is always more than the 0.1-in. penetration.

9.2 *Bearing Ratio*—Using corrected stress values taken from the stress penetration curve for 0.100 in. (2.54 mm) and 0.200 in. (5.08 mm) penetrations, calculate the bearing ratios for each by dividing the corrected stresses by the standard stresses of 1000 psi (6.9 MPa) and 1500 psi (10.3 MPa) respectively, and multiplying by 100. Also, calculate the bearing ratios for the maximum stress, if the penetration is less than 0.200 in. (5.08 mm) interpolating the standard stress. The bearing ratio reported for the soil is normally the one at 0.100 in. (2.54 mm) penetration. When the ratio at 0.200 in. (5.08 mm) penetration is greater, rerun the test. If the check test gives a similar result, use the bearing ratio at 0.200 in. (5.08 mm) penetration.

NOTE 8—If bearing ratio values at penetrations of 0.300 (7.62 mm),

0.400 (10.16 mm) and 0.500 in. (12.7 mm) are desired, the corrected stress values of these penetrations should be divided by the standard stresses of 1900 psi (13.1 MPa), 2300 psi (15.9 MPa), 2600 psi (17.9 MPa), respectively, and multiplied by 100.

9.3 *Design CBR for One Water Content Only*—Using the data obtained from the three specimens, plot the CBR versus molded dry unit weight relation as illustrated in Fig. 3. Determine the design CBR at the percentage of the maximum dry unit weight requested.

9.4 *Design CBR for Water Content Range*—Plot the data from the tests at the three compactive efforts as shown in Fig. 4. The data plotted as shown represents the response of the soil over the range of water content specified. Select the CBR for reporting as the lowest CBR within the specified water content range having a dry unit weight between the specified minimum and the dry unit weight produced by compaction within the water content range.

10. Report

10.1 The report shall include the following:

10.1.1 Method used for preparation and compaction of specimen: Test Methods D 698 or D 1557, or other, with description.

10.1.2 Condition of sample (unsoaked or soaked).

10.1.3 Dry density (unit weight) of sample before soaking, kg/m³ (lb/ft³).

10.1.4 Dry density (unit weight) of sample after soaking kg/m³ (lb/ft³).

10.1.5 Moisture content of sample in percent:

10.1.5.1 Before compaction.

10.1.5.2 After compaction.

10.1.5.3 Top 1-in (25.4-mm) layer after soaking.

10.1.5.4 Average after soaking.

10.1.6 Swell (percentage of initial height).

10.1.7 Bearing ratio of sample (unsoaked or soaked), percent.

10.1.8 Surcharge amount.

10.1.9 Any special sample preparation and testing procedures (for example: for self cementing materials).

10.1.10 Sample identification (location, boring number, etc.).

10.1.11 Any pertinent testing done to identify the sample such as: soil classifications per Test Method D 2487, visual classification per Practice D 2488, Atterberg limits per Test Method D 4318, gradation per Method D 422 etc.

10.1.12 The percent material retained on the 19-mm sieve for those cases where scalping and replacement is used.

11. Precision and Bias

11.1 No available methods provide absolute values for the soil bearing strength derived by this test method; therefore, there is no meaningful way to obtain an evaluation of bias.

11.2 At present, sufficient data for determining the precision of this test method has not been gathered. Users are encouraged to submit data to the subcommittee for inclusion in the statement. One user, based on seven repetitions, has developed a IS % of 8.2 % (compacted per Test Method D 698) and 5.9 % (compacted per Test Method D 1557). See Appendix X1 for the data used.

12. Keywords

12.1 This standard is indexed under the following terms:

California Bearing Ratio	Used For, Narrower Term
Pavement Subgrade	Used For, Narrower Term
Subgrade	Related Term, Broader Term
Pavement Subbase	Used For, Narrower Term
Subbase	Used For, Broader Term
Pavement Base Course	Used For, Narrower Term
Base Course	Used For, Broader Term
Strength of Soil	Used For
Pavement Design	Used For, Narrower Term
Acceptance Tests	Used For
Bearing Capacity	Used For
Materials Evaluations	Used For
Bearing Ratio	Used For, Broader Term
Load Penetration Curve	Used For
Design	Used For, Broader Term
Earthfill	Related To
Cohesive Soils	Used For
Compressive Strength	Used For
Flexible Pavements	Used For
Foundation Investigations	Used For
Soil Tests	Used For

APPENDIX

(Nonmandatory Information)

X1. Compactive Effort

See Fig. X1.1 for more information.

STANDARD (D698)			MODIFIED (D1557)		
CBR			CBR		
(x)	(x-x)	(x-x) ²	(x)	(x-x)	(x-x) ²
16.7	.5	.25	77.0	3	9
15.7	1.5	2.25	70.2	3.8	14.44
18.2	1.0	1	80.8	6.8	46.24
18.2	1.0	1	68.2	5.8	33.64
18.8	1.6	2.56	76.7	2.7	7.29
19.3	2.1	4.41	71.7	2.3	5.29
17.9	0.7	.49	73.3	0.7	.49
-----			-----		
\bar{x} = 124.8		(x-x) ² 11.96	\bar{x} = 517.9		(x-x) ² 116.39
\bar{x} = 17.2			\bar{x} = 74.0		
S = 11.96			S = 116.39 = 19.39		
-----			-----		
6			6		
IS (one sigma) = 1.41			IS = 4.4		
IS % = 1.41 X 100 = 8.2%			IS % = 4.4 x 100 = 5.9%		
-----			-----		
17.2			74		
D2S % = 22.6%			D2S % = 16.7%		

- NOTES:**
- All Material passed the #10 sieve
 - Over 90% of all material passed the #40 sieve
 - Method A of AASHTO T99 & T180 used
 - Unit weights were 110 PCF ± (D698) and 122 PCF ± (D1557)
 - 7 test repetitions
 - The above data is from one user
 - The (IS) and (D2S) limits represent the limits as described in ASTM Practice C670.

FIG. X1.1 Compactive Effort

SUMMARY OF CHANGES

(1) Terminology D 653 was added to Section 2.

- (2) Wording in Fig. 1 was changed from “equally spaced” to “uniformly spaced” to match the wording in the text.
- (3) Section 5.1 was revised and a new Table 1 was added. Table

2 is the former Table 1.

(4) This Summary of Changes section has been added.

ASTM International takes no position respecting the validity of any patent rights asserted in connection with any item mentioned in this standard. Users of this standard are expressly advised that determination of the validity of any such patent rights, and the risk of infringement of such rights, are entirely their own responsibility.

This standard is subject to revision at any time by the responsible technical committee and must be reviewed every five years and if not revised, either reapproved or withdrawn. Your comments are invited either for revision of this standard or for additional standards and should be addressed to ASTM International Headquarters. Your comments will receive careful consideration at a meeting of the responsible technical committee, which you may attend. If you feel that your comments have not received a fair hearing you should make your views known to the ASTM Committee on Standards, at the address shown below.

This standard is copyrighted by ASTM International, 100 Barr Harbor Drive, PO Box C700, West Conshohocken, PA 19428-2959, United States. Individual reprints (single or multiple copies) of this standard may be obtained by contacting ASTM at the above address or at 610-832-9585 (phone), 610-832-9555 (fax), or service@astm.org (e-mail); or through the ASTM website (www.astm.org).