



Standard Test Methods for Calibration of Laboratory Mechanical-Rammer Soil Compactors¹

This standard is issued under the fixed designation D 2168; the number immediately following the designation indicates the year of original adoption or, in the case of revision, the year of last revision. A number in parentheses indicates the year of last reapproval. A superscript epsilon (ϵ) indicates an editorial change since the last revision or reapproval.

1. Scope *

1.1 These test methods for the calibration of mechanical soil compactors are for use in checking and adjusting mechanical devices used in laboratory compacting of soil and soil-aggregate in accordance with Test Methods D 698, D 1557 and other methods of a similar nature which might specify this method. Calibration for use with one method does not qualify the equipment for use with another method.

1.2 The weight of the mechanical rammer is adjusted as described in 5.4 and 6.5 in order to provide that the mechanical compactor will produce the same result as the manual compactor.

1.3 Two alternative procedures are provided as follows:

	Section
Test Method A Calibration based on the compaction of a selected soil sample	5
Test Method B Calibration based on the deformation of a standard lead cylinder	6

1.4 If a mechanical compactor is calibrated in accordance with the requirements of either Test Method A or Test Method B, it is not necessary for it to meet the requirements of the other method.

1.5 The values stated in inch-pound units are to be regarded as the standard. The values given in parentheses are for information only.

1.6 *This standard does not purport to address all of the safety concerns, if any, associated with its use. It is the responsibility of the user of this standard to establish appropriate safety and health practices and determine the applicability of regulatory limitations prior to use.*

2. Referenced Documents

2.1 ASTM Standards:

D 653 Terminology Relating to Soil, Rock, and Contained Fluids²

¹ These test methods are under the jurisdiction of ASTM Committee D18 on Soil and Rock and are the direct responsibility of Subcommittee D 18.03 on Texture, Plasticity, and Density Characteristics of Soils.

Current edition approved Nov. 10, 2002. Published January 2003. Originally approved in 1990. Last previous edition D 2168 – 02.

² *Annual Book of ASTM Standards*, Vol 04.08.

D 698 Test Method for Laboratory Compaction Characteristics of Soil Using Standard Effort (12 400 ft-lbf/ft³ (600 kn-m/m³))²

D 1557 Test Method for Laboratory Compaction Characteristics of Soil Using Modified Effort (56 000 ft-lbf/ft³ (2700 kn-m/m³))²

D 2487 Classification of Soils for Engineering Purposes (Unified Soil Classification System)²

D 3740 Practice for Agencies Engaged in the Testing and/or Inspection of Soil and Rock as Used Engineering Design and Construction²

E 11 Specification for Wire-Cloth Sieves for Testing Purposes³

E 145 Specification for Gravity-Convection and Forced-Ventilation Ovens⁴

3. Significance and Use

3.1 Mechanical compactors are commonly used to replace the hand compactors required for Test Methods D 698 and D 1557 in cases where it is necessary to increase production.

3.2 The design of mechanical compactors is such that it is necessary to have a calibration process that goes beyond determining the mass and drop of the hammer.

NOTE 1—The quality of the result produced by this standard is dependent on the competence of the personnel performing it, and the suitability of the equipment and facilities used. Agencies that meet the criteria in Practice D 3740 are generally considered capable of competent and objective testing/sampling/inspection/and the like. Users of this standard are cautioned that compliance with Practice D 3740 does not in itself assure reliable results. Reliable results depend on many factors; Practice D 3740 provides a means of evaluating some of those factors.

4. Apparatus

4.1 For Test Method A, in addition to the apparatus requirements specified in Test Methods D 698 and D 1557, the following is required:

4.1.1 *Drying Oven*—Thermostatically controlled oven, preferably of the forced-draft type, meeting the requirements

³ *Annual Book of ASTM Standards*, Vol 14.02.

⁴ *Annual Book of ASTM Standards*, Vol 14.04.

*A Summary of Changes section appears at the end of this standard.

for Specification E 145 and capable of maintaining a uniform temperature of $140 \pm 5^\circ\text{F}$ ($60 \pm 3^\circ\text{C}$) throughout the drying chamber.

4.2 For Test Method B, in addition to the apparatus requirements specified in Test Methods D 698 and D 1557, the following are required:

4.2.1 *Lead Deformation Apparatus*—A lead deformation apparatus consisting of an anvil, guide collar, and striking pin, as shown in Fig. 1.

4.2.2 *Micrometer*—A 1-in. or 25-mm outside micrometer caliper reading to 0.001 in. or 0.02 mm, for determining the length of the lead cylinders. As an alternative, a dial comparator of equal accuracy may be used to determine either the length of the lead cylinder, or of the complete lead deformation apparatus assembly. In order to measure the complete assembly, a dial comparator with a minimum opening of 2 in. (51 mm) and a travel of 1 in. (25 mm) is required (see Fig. 2).

NOTE 2—The use of vernier calipers is not recommended since they can produce erroneous readings if not zeroed correctly or if the vernier caliper is not of high quality.

4.2.3 *Guide Sleeve Pedestal*—A guide sleeve pedestal for use with guide sleeves used to control the drop of the manual rammers in Test Methods D 698 and D 1557 (see Fig. 3).

4.2.4 *Test Cylinders*—A supply of commercially pure lead test cylinders having individual weights such that the lightest cylinder is within 0.06 g of the heaviest, each having a length of 0.675 ± 0.005 in. (17.1 ± 0.1 mm) and a diameter of 0.310 ± 0.002 in. (7.87 ± 0.05 mm).⁵ A minimum of ten test cylinders is required for the calibration of one mechanical compactor. However, depending on circumstances, as many as 100 test cylinders may be required.

5. Procedure—Test Method A

5.1 Thoroughly inspect the mechanical and manual compactors for evidence of wear, malfunction, and need of servicing and adjustment. Clean, adjust, and lubricate the compactors so as to meet all requirements of the manufacturer, and the applicable method under which they will be used and for which the mechanical compactor is to be calibrated. Operate the compactor for a minimum of 25 drops to cause friction in the parts to become constant, allowing the rammer to fall on soil or other soft material.

NOTE 3—In order to provide satisfactory results, mechanical compactors must be in excellent working condition. Improper operation of the raising and release mechanisms can introduce serious errors.

5.2 Obtain approximately 50 lb (23 kg) of soil classified as CL in accordance with Classification D 2487. If excessive moisture is present, dry the soil until it becomes friable. Drying may be in air or by use of a drying apparatus such that the temperature of the sample does not exceed 140°F (60°C). Pass the soil through a No. 4 (4.75-mm) sieve conforming to the

requirements of Specification E 11. Discard any material remaining on the sieve, and thoroughly blend the material passing the sieve until it is uniform. The material shall then be prepared for compaction in accordance with either Methods D 698 or D 1557 as appropriate for the mechanical compactor being calibrated.

NOTE 4—The amount of soil used will vary greatly depending on the number of water content unit mass determinations required.

5.3 Using the soil prepared in accordance with 5.2, determine optimum moisture and maximum dry unit weight by Method A of either Test Methods D 698 or D 1557 or whichever method is appropriate for the mechanical compactor being calibrated. Prepare one curve using the mechanical compactor and another using the manual compactor. Record the values of γ_{max} , the maximum dry unit weight obtained with the manual compactor, and γ'_{max} , the maximum dry unit weight obtained with the mechanical compactor.

5.4 Determine W , the percentage difference of maximum dry unit weight values for a single set of data (see Section 7). If the absolute value of W is equal to or less than 2.0, the mechanical compactor is satisfactory for immediate use. If the absolute value of W is greater than 2.0, then obtain two additional sets of data. Use the same soil sample, prepared in accordance with 5.2, that was used previously. Determine W , the average percentage difference of maximum dry unit mass values for three sets of data (see Section 7). If the absolute value of W is equal to or less than 2.0, the mechanical compactor is satisfactory for immediate use. If the absolute value of \bar{W} is greater than 2.0, then adjust the rammer mass of the mechanical compactor in accordance with 5.5. Then secure three new values of γ'_{max} and compute a new value of \bar{W} . Repeat this procedure until the absolute value of \bar{W} is equal to or less than 2.0.

5.5 Make changes in the weight of the mechanical hammer with due consideration to good workmanship. Makeshift modifications that could affect the operation of the mechanical compactor are not permitted. The maximum permissible variation in the weight of the mechanical hammer as the result of calibration is as follows: The total mass added to the original mass of the hammer as received from the manufacturer must not exceed ten percent of its original mass. If it is necessary to add more than ten percent, the mechanical compactor is to be rebuilt or repaired.

NOTE 5—This assumes that some mass has been added to the rammer as received from the manufacturer. Normally, mass will have to be added to the original rammer. If the calibration indicates that the mass of the original rammer needs to be reduced to less than 5.5 lbf (2.49 kg) or 10 lbf (4.54 kg) depending on the test method rammer standard, carefully recheck all equipment and calibrations and report the procedure. If removal of mass is still indicated, the height-of-drop should be adjusted.

NOTE 6—Graphical procedures are helpful in estimating the correct amount of mass to be added or subtracted.

5.6 If a larger change than that permitted in 5.5 is found to be necessary, then improper operation of the mechanical

⁵ Lead test cylinders are available from the Hornady Manufacturing Co., P.O. Box 1848, Grand Island, Nebr. 68801 in lots of 500.

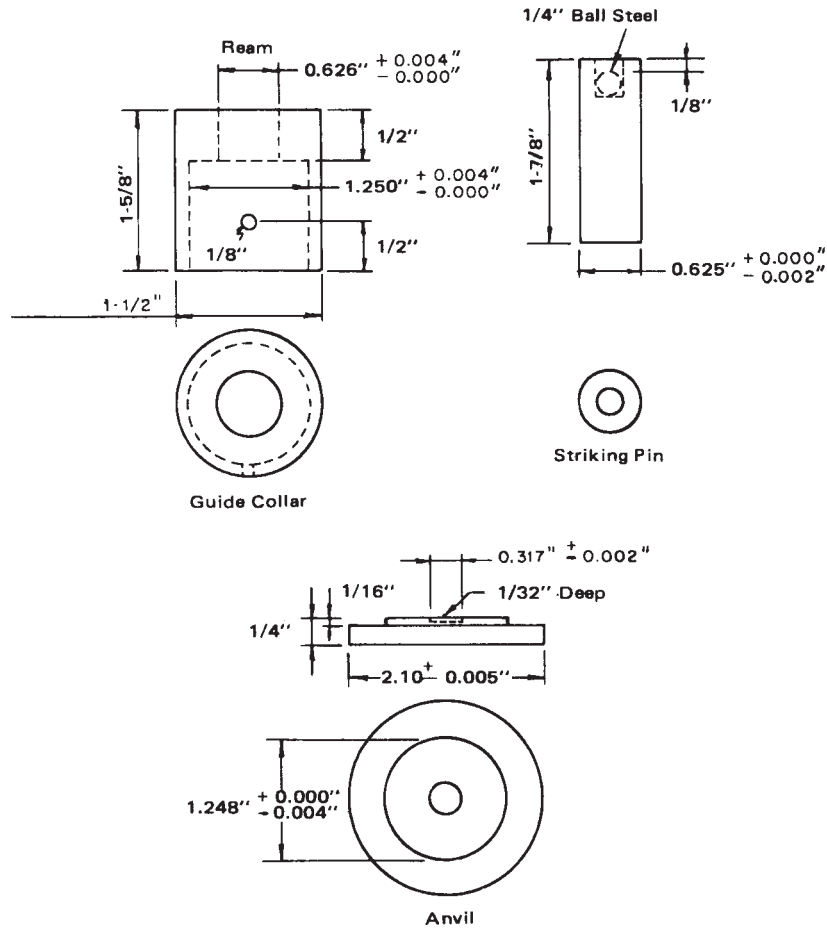

in.	mm
2.10	53.34
$1\frac{7}{8}$	48
$1\frac{5}{8}$	41
$1\frac{1}{2}$	38
1.250	31.75
1.248	31.70
0.626	15.90
0.625	15.88
$\frac{1}{2}$	13
0.317	8.05
$\frac{1}{4}$	6.4
$\frac{1}{8}$	3.2
$\frac{1}{16}$	1.6
$\frac{1}{32}$	0.79
0.005	0.13
0.004	0.10
0.002	0.05
0.001	0.02

NOTE 1—Inside dimension of guide collar should slip easily over raised section of anvil without excessive free play. Anvil should slip easily inside guide sleeve pedestal without excessive free play.

FIG. 1 Lead Deformation Apparatus

compactor is indicated. Carefully inspect and adjust the mechanical compactor in order to discover and eliminate the cause of the malfunction and repeat the calibration procedure.

5.7 Do not use the mechanical compactor if the indicated weight change still exceeds that permitted in 5.5.

6. Procedure—Method B

6.1 Inspect and adjust the mechanical and manual compactors as described in 5.1 of Method A.

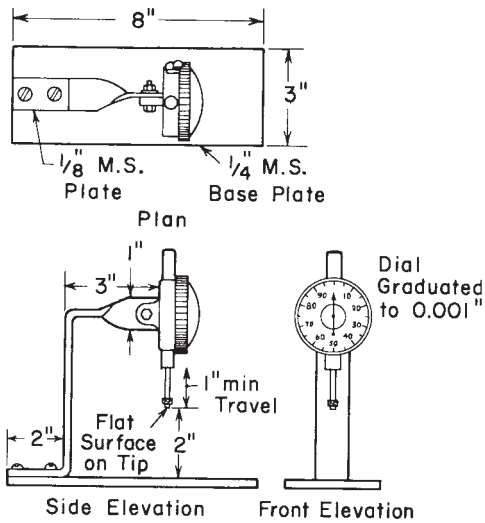

in.	mm
8	203
3	76
2	51
1	25
1/4	6.4
1/8	3.2
0.001	0.02

FIG. 2 Dial Comparator

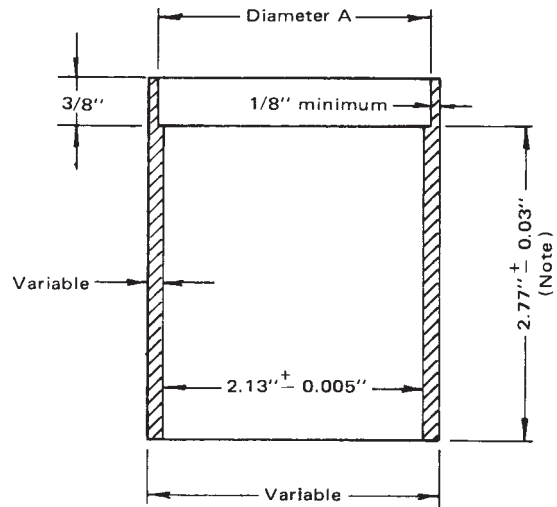

in.	mm
2.77	70.4
2.13	54.10
3/8	10
1/8	3.2
0.03	0.8
0.005	0.13

NOTE 1—This dimension must be equal to the height of the lead deformation apparatus when assembled with the lead cylinder in place, within a tolerance of ± 0.01 in. (± 0.25 mm).

NOTE 2—Diameter A is such that guide sleeve of rammer fits easily into recess without free play.

FIG. 3 Guide Sleeve Pedestal

6.2 Deformation by the Manual Compactor—Obtain the deformation value for the manual compactor as follows:

6.2.1 Select a set of lead cylinders from the same lot or shipment. Remove any burrs from the ends of the lead cylinders using a fine grade of emery cloth.

NOTE 7—Deformation of the lead cylinders is affected by changes in temperature. Take precautions to maintain the cylinders within $\pm 5^\circ\text{F}$ ($\pm 2.7^\circ\text{C}$) during the calibration of the mechanical compactor and the securing of the manual compactor values.

6.2.2 Obtain c_1 , the (initial) micrometer or dial comparator reading before impact, following the procedures described in 6.2.5.

6.2.3 Place the base plate of the compaction mold on a rigid foundation. On the base plate, place the assembled lead deformation apparatus with the lead cylinder (see Fig. 4) and guide sleeve pedestal in place. Insert the guide sleeve of the manual compactor into the recess in the guide sleeve pedestal. Check that the distance from rammer release point to striking pin contact meets the specified requirements. Apply one drop of the manual rammer with the guide sleeve of the manual compactor held vertically, so that the rammer does not strike the guide sleeve pedestal.

6.2.4 Obtain c_2 , the micrometer or dial comparator reading after impact, following the procedures described in 6.2.5. The difference between dial readings c_1 and c_2 is equal to D , the deformation value.

6.2.5 Obtain readings for c_1 and c_2 either by:

6.2.5.1 Direct measurement of the length of the lead cylinder, using the outside micrometer caliper or an equivalent dial comparator.

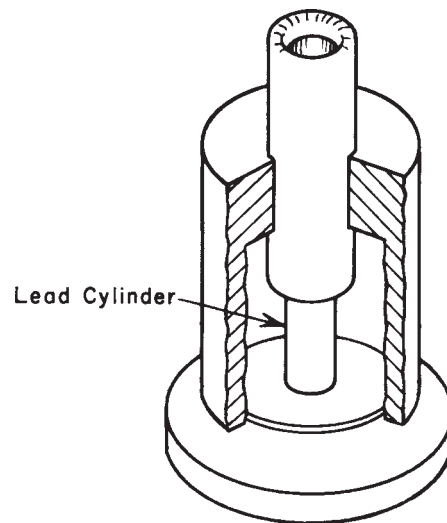

FIG. 4 Lead Deformation Apparatus Assembly

6.2.5.2 Obtaining a measurement of the assembled deformation apparatus, secured by placing it in the dial comparator so that the top center of the 1/4-in. (6.4-mm) steel ball of the striking pin is directly under the tip of the dial stem

6.2.6 Repeat 6.2.2-6.2.5 using an unused lead cylinder for each determination until five deformation values are obtained that do not vary more than 2.0 % from \bar{D} , the average value; that is, the absolute value of v_1 must be less than 2.0 for the five

values selected (see 7.2). The deformation value for the manual method shall be taken as \bar{D} .

6.3 *Deformation by the Mechanical Compactor*—Obtain the deformation value (change in height) of the lead cylinder by the mechanical compactor as follows:

6.3.1 Select a set of at least five lead cylinders from the same lot or shipment. Remove any burrs from the ends of the lead cylinders using a fine grade emery cloth (see Note 7).

6.3.2 Place the assembled lead deformation apparatus on the base of the mechanical compactor at such location that the striking pin will be centered on the face of the rammer at the moment of contact of the two.

6.3.3 Obtain the average deformation value \bar{D}' for the mechanical compactor using the same procedure specified in 6.2, except do not use the guide sleeve pedestal. The mechanical compactor must operate in the normal manner so as to lift the rammer from the striking pin contact elevation to the specified release height. Raising and releasing the rammer manually or by any procedure other than that of normal automatic operation is prohibited.

6.3.4 Repeat 6.3.2 and 6.3.3 on remaining lead cylinders in set..

6.4 Calculate v_2 , the percentage difference of the average deformation value, using the mechanical rammer, from the average deformation value, using the manual rammer (see 7.2). If v_2 does not vary more than ± 2.0 , then the mechanical compactor is satisfactory for immediate use.

6.5 If v_2 exceeds ± 2.0 , repeat 6.3.2 and 6.3.3, securing two additional values of v_2 . Average the absolute value of all three values of v_2 . If this average is equal to or less than 2.0, the mechanical compactor is satisfactory for immediate use. If the absolute mean value of v_2 is greater than 2.0, then adjust the rammer weight of the mechanical rammer in accordance with 5.5 and obtain additional sets of mechanical compactor data until the mean value of v_2 for three sets of data is equal to or less than 2.0.

6.6 Follow the same procedure as described for Test Method A in 5.5, 5.6, and 5.7.

7. Calculations

7.1 Calculate the percentage difference of maximum unit weight values as follows:

$$W = [(\gamma'_{\max} - \gamma_{\max})/\gamma_{\max}] \times 100 \quad (1)$$

$$\bar{W} = [(\bar{\gamma}'_{\max} - \bar{\gamma}_{\max})/\bar{\gamma}_{\max}] \times 100$$

where:

W = percentage difference of maximum unit weight values for a single set of data,

\bar{W} = average percentage difference of maximum unit weight values for three sets of data,

γ_{\max} = maximum unit weight value obtained by the manual method,

$\bar{\gamma}_{\max}$ = average of three maximum unit weight values obtained by the manual method,

γ'_{\max} = maximum unit weight value obtained by the mechanical method, and

$\bar{\gamma}'_{\max}$ = average of three maximum unit weight values obtained by the mechanical method.

7.2 Calculate the percentage difference of average lead deformation values as follows:

$$D = c_1 - c_2 \quad (2)$$

$$\bar{D} = \Sigma(c_1 - c_2)/N$$

$$D' = c'_1 - c'_2$$

$$\bar{D}' = \Sigma(c'_1 - c'_2)/N$$

$$v_1 = [(D - \bar{D})/\bar{D}] \times 100$$

$$v'_1 = [(D' - \bar{D}')/\bar{D}'] \times 100$$

$$v_2 = [(\bar{D} - \bar{D}')/\bar{D}'] \times 100$$

where:

c_1 = micrometer or dial comparator reading before impact, manual rammer,

c_2 = micrometer or dial comparator reading after impact, manual rammer,

c'_1 = micrometer or dial comparator reading before impact, mechanical rammer,

c'_2 = micrometer or dial comparator reading after impact, mechanical rammer,

D = deformation value for single lead cylinder, manual rammer,

D' = deformation value for single lead cylinder, mechanical rammer,

\bar{D} and \bar{D}' = average deformation values for manual and mechanical rammers respectively, where v_1 and v'_1 values do not exceed ± 2.0 %,

v_1 = percentage variation from the mean of individual deformation values obtained using the manual rammer,

v'_1 = percentage variation from the mean of individual deformation values obtained using the mechanical rammer,

v_2 = percentage difference of the average deformation value using the mechanical rammer from the average deformation value using the manual rammer, and

N = number of tests.

8. Report

8.1 The report shall include the following information:

8.1.1 Identification of laboratory compactor by make, model, and serial number,

8.1.2 ASTM designation of laboratory compaction procedure for which the compactor was calibrated,

8.1.3 Date of calibration,

8.1.4 Test Method used (A or B),

8.1.5 For Test Method A only: classification of soil used by Classification D 2487,

8.1.6 For Test Method A only: experimental values of γ_{\max} and γ'_{\max} ,

8.1.7 For Test Method B only: experimental values of c_1 , c'_1 , c_2 , and c'_2 ,

8.1.8 Calculations, and

8.1.9 Initial and adjusted weights of rammer.

9. Precision and Bias

9.1 These test methods describe calibration methods that do not produce a test result; therefore, neither a precision or bias statement is applicable.

10. Keywords

10.1 laboratory compaction; mechanical rammer; moisture density

SUMMARY OF CHANGES

In accordance with Committee D18 policy, this section identifies the location of changes to this standard since the last edition (02) that may impact the use of this standard.

(1) Changes the SI tolerance for the oven temperature in Section 4.1.1.

ASTM International takes no position respecting the validity of any patent rights asserted in connection with any item mentioned in this standard. Users of this standard are expressly advised that determination of the validity of any such patent rights, and the risk of infringement of such rights, are entirely their own responsibility.

This standard is subject to revision at any time by the responsible technical committee and must be reviewed every five years and if not revised, either reapproved or withdrawn. Your comments are invited either for revision of this standard or for additional standards and should be addressed to ASTM International Headquarters. Your comments will receive careful consideration at a meeting of the responsible technical committee, which you may attend. If you feel that your comments have not received a fair hearing you should make your views known to the ASTM Committee on Standards, at the address shown below.

This standard is copyrighted by ASTM International, 100 Barr Harbor Drive, PO Box C700, West Conshohocken, PA 19428-2959, United States. Individual reprints (single or multiple copies) of this standard may be obtained by contacting ASTM at the above address or at 610-832-9585 (phone), 610-832-9555 (fax), or service@astm.org (e-mail); or through the ASTM website (www.astm.org).