



Designation: D 5731 – 9502

Standard Test Method for Determination of the Point Load Strength Index of Rock¹

This standard is issued under the fixed designation D 5731; the number immediately following the designation indicates the year of original adoption or, in the case of revision, the year of last revision. A number in parentheses indicates the year of last reapproval. A superscript epsilon (ϵ) indicates an editorial change since the last revision or reapproval.

1. Scope*

1.1 This test method covers the guidelines, requirements, and procedures for determining the point load strength index of rock. Specimens in the form of rock cores, blocks, or irregular lumps can be tested by this test method. This test method can be performed in the field or laboratory because the testing machine is portable. This is an index test and is intended to be used to classify and characterize rock.

1.2 This test method applies to hard rock (compressive strength over 15 MPa (2200 psi)).

1.3 All observed and calculated values shall conform to the guidelines for significant digits and rounding established in Practice D 6026.

1.3.1 The method used to specify how data are collected, calculated, or recorded in this standard is not directly related to the accuracy to which the data can be applied in design or other uses, or both. How one applies the results obtained using this standard is beyond its scope.

1.4 The values stated in the SI units are to be regarded as standard.

1.4.5 *This standard does not purport to address all of the safety concerns, if any, associated with its use. It is the responsibility of the user of this standard to establish appropriate safety and health practices and determine the applicability of regulatory limitations prior to use.*

2. Referenced Documents

2.1 *ASTM Standards:*

¹ This test method is under the jurisdiction of ASTM Committee D-18 on Soil and Rock and is the direct responsibility of Subcommittee D18.12 on Rock Mechanics. Current edition approved ~~May 15, 1995~~ Nov. 10, 2002. Published January 2003. Originally approved in 1995. Last previous edition approved in 1995 as D 5731-95.

*A Summary of Changes section appears at the end of this standard.

D 653 Terminology Relating to Soil, Rock, and Contained Fluids²

D 2216 Test Method for Laboratory Determination of Water (Moisture) Content of Soil and Rock²

D 2938 Test Method for Unconfined Compressive Strength of Intact Rock Core Specimens²

D 3740 Practice for Minimum Requirements for Agencies Engaged in the Testing and/or Inspection of Soil and Rock as Used in Engineering Design and Construction²

D 5079 Practices for Preserving and Transporting Rock Core Samples²

D 6026 Practice for Using Significant Digits in Geotechnical Data³

E 18 Test Methods for Rockwell Hardness and Rockwell Superficial Hardness of Metallic Materials⁴

2.2 ISRM Standard:

Suggested Methods for Determining Point Load Strength⁵

3. Terminology

3.1 For definitions of terms used in this test method refer to Terminology D 653.

3.2 Definitions of Terms Specific to This Standard:

3.2.1 point load strength index—an indicator of strength (see 9.1) obtained by subjecting a rock specimen to an increasingly concentrated point load, applied through a pair of truncated, conical platens, until failure occurs.⁵

4. Summary of Test Method

4.1 This index test is performed by subjecting a rock specimen to an increasingly concentrated load until failure occurs by splitting the specimen. The concentrated load is applied through coaxial, truncated conical platens. The failure load is used to calculate the point load strength index and to estimate the uniaxial compressive strength.

5. Significance and Use

5.1 The uniaxial compression test (see Test Method D 2938) is used to determine compressive strength of rock specimens, but it is a time-consuming and expensive test that requires specimen preparation. When extensive testing is required for preliminary and reconnaissance information, alternative tests such as the point load test can be used in the field to reduce the time and cost of compressive strength tests.

5.2 The point load strength test is used as an index test for strength classification of rock materials. The test results should not be used for design or analytical purposes.

5.3 This test method is performed to determine the point load strength index ($I_p(50)$) of rock specimens, and the point load strength anisotropy index ($I_a(50)$) that is the ratio of point load strengths on different axes that result in the greatest and least values.

5.4 Rock specimens in the form of either core (the diametral and axial tests), cut blocks (the block test), or irregular lumps (the irregular lump test) are tested by application of concentrated load through a pair of truncated, conical platens. Little or no specimen preparation is required. However, the results can be highly influenced by how the specimen is treated from the time it is obtained until the time it is tested. Therefore, it may be necessary to handle specimens in accordance with Practice D 5079.

NOTE 1—The quality of the result produced by this standard is dependent upon the competence of the personnel performing it, and the suitability of the equipment and facilities used. Agencies that meet the criteria of Practice D 3740 are generally considered capable of competent and objective testing and sampling. Users of this standard are cautioned that compliance with Practice D 3740 does not in itself assure reliable results. Reliable results depend on many factors; Practice D 3740 provides a means of evaluating some of those factors.

6. Apparatus

6.1 *General*—A point load tester (see Fig. 1) consists of a loading system typically comprised of a loading frame, platens, a measuring system for indicating load, P , (required to break the specimen), and a means for measuring the distance, D , between the two platen contact points. The equipment shall be resistant to shock and vibration so that the accuracy of readings is not adversely affected by repeated testing.

6.2 *Loading System:*

6.2.1 The loading system shall have a loading frame with a platen-to-platen clearance that allows testing of rock specimens in the required size range. Typically, this range is within 30 to 85 mm so that an adjustable distance is available to accommodate both small and large specimens.

6.2.2 The loading capacity shall be sufficient to break the largest and strongest specimens to be tested.

² Annual Book of ASTM Standards, Vol 04.08.

³ "Suggested Methods for Determining Point Load Strength", International Society for Rock Mechanics Commission on Testing Methods, *Int. J. Rock Mech. Min. Sci. and Geomechanical Abstr.*

⁴ Annual Book of ASTM Standards, Vol-22, No. 2, 1985, pp. 51–60, 04.09.

⁵ Annual Book of ASTM Standards, Vol 03.01.

⁵ "Suggested Methods for Determining Point Load Strength", International Society for Rock Mechanics Commission on Testing Methods, *Int. J. Rock Mech. Min. Sci. and Geomechanical Abstr.*, Vol 22, No. 2, 1985, pp. 51–60.

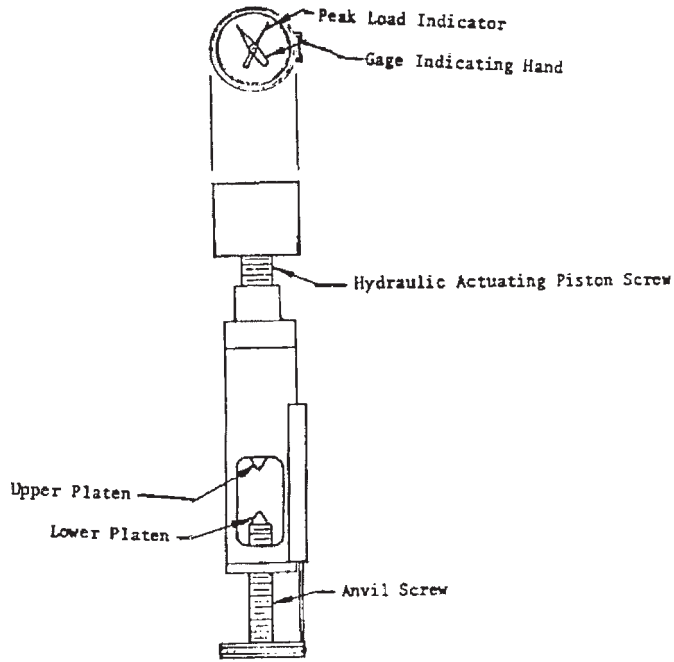

FIG. 1 An Example of a Loading System (The Point Load Strength Index Test)

6.2.3 The test machine shall be designed and constructed so that it does not permanently distort during repeated applications of the maximum test load, and so that the platens remain coaxial within ± 0.2 mm throughout testing. No spherical seat or other nonrigid component is permitted in the loading system. Loading system rigidity is essential to avoid slippage when specimens of irregular geometry are tested.

6.2.4 Truncated, conical platens, as shown on Fig. 2, are to be used. The 60° cone and 5-mm radius spherical platen tip shall meet tangentially. The platens shall be of hard material (Rockwell 58 HRC, as explained in Test Method E 18) such as tungsten carbide or hardened steel so they remain undamaged during testing.

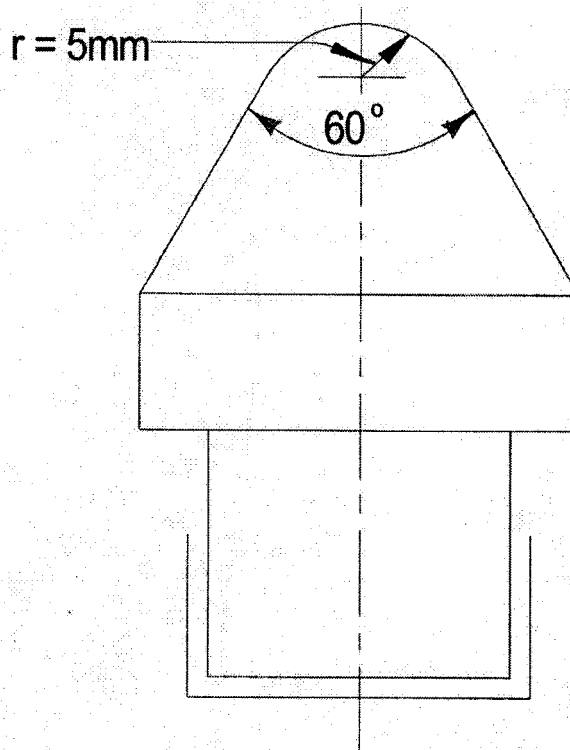

FIG. 2 Platen Dimensions

6.3 Load Measuring System:

6.3.1 A load measuring system, for example a load cell or a hydraulic pressure gage, that will indicate failure load, P , required to break specimen. The system should conform to the requirements of 6.3.2-6.3.4.

6.3.2 Measurements of failure load, P , shall be to a precision of $\pm 5\%$ or better of full-scale load-measuring system, irrespective of the size and strength of specimen that is tested.

6.3.3 Failure is often sudden and a peak load indicator is required so the failure load can be recorded after each test.

6.3.4 The system should be capable of using interchangeable measuring devices in order to be consistent with the estimated strength of rock (point load strength of rock is usually an order of magnitude lower than the compressive strength of rock).

6.4 Distance Measuring System:

6.4.1 The distance measuring system, a vernier direct reading scale, should connect to the loading frame for measuring the distance, D , between specimen-platen contact points and conform to requirements 6.4.2 and 6.4.3.

6.4.2 Measurements of D shall be to an accuracy of $\pm 2\%$ or better of distance between contact points, irrespective of the size and strength of specimen that is tested.

6.4.3 The measuring system shall allow a check of the “zero displacement” value when the two platens are in contact and should include a zero adjustment.

6.4.4 An instrument such as a caliper or a steel rule is required to measure the width, W , (with an accuracy of $\pm 5\%$) of specimens for all but the diametral test.

6.5 *Miscellaneous Items*—Diamond saw, chisels, towels, marking pens, and plotting paper.

7. Test Specimens

7.1 *Sampling*—Rock samples are grouped on the basis of both rock type and estimated strength. When testing core or block specimens at least ten specimens are selected. When testing irregular-shaped specimens obtained by other means at least 20 specimens are selected. Specimens in the form of core are preferred for a more precise classification.

7.2 *Dimensions*—The specimen’s external dimensions shall not be less than 30 mm and not more than 85 mm with the preferred dimension about 50 mm.

7.3 *Size and Shape*—The size and shape requirements for diametral, axial, block, or irregular lump testing shall conform with the recommendations shown on Fig. 3. The sides of the specimens shall be free from abrupt irregularities that can generate stress concentrations. No specimen preparation is required.

7.4 *Water Content*—Using Test Method D 2216, determine the water content of each specimen after testing since it can affect the value of the point load strength.

7.5 *Marking and Measuring Specimens*— The specimens shall be properly marked and measured.

7.5.1 *Marking*—The desired test orientation of the specimen shall be indicated by marking lines on the specimen. These lines are used for centering the specimen in the testing machine, and to ensure proper orientation during testing. These lines may also be used as reference lines for measuring thickness and diameter.

7.5.2 *Measuring*—Measure each dimension of a specimen at three different places, and calculate the averages.

8. Procedure

8.1 Diametral Test:

8.1.1 Core specimens with length/diameter ratio greater than one are suitable for diametral testing.

8.1.2 Insert a specimen in the test device and close the platens to make contact along a core diameter. Ensure that the distance, L , between the contact points and the nearest free end is at least 0.5 times the core diameter (see Fig. 3(*a*)).

8.1.3 Determine and record the distances D and L (see Fig. 3).

8.1.4 Steadily increase the load such that failure occurs within 10 to 60 s, and record failure load, P . The test should be rejected if the fracture surface passes through only one platen loading point (see Fig. 4(*d*)).

8.1.5 The procedures in 8.1.2-8.1.4 are repeated for each specimen of the rock type.

8.2 Axial Test:

8.2.1 Core specimens with length/diameter ratio of $\frac{1}{3}$ to 1 are suitable for axial testing (see Fig. 3(*b*)). Suitable specimens can be obtained by saw-cutting or chisel-splitting.

8.2.2 Insert a specimen in the test machine and close the platens to make contact along a line perpendicular to the core end faces (in the case of isotropic rock, the core axis, but see 8.4 for anisotropic rock).

8.2.3 Record the distance, D , between platen contact points (see Fig. 3). Record the specimen width, W , perpendicular to the loading direction, with an accuracy of $\pm 5\%$.

8.2.4 Steadily increase the load such that failure occurs within 10 to 60 s, and record the failure load, P . The test should be rejected if the fracture surface passes through only one loading point (see Fig. 4(*e*)).

8.2.5 Procedures 8.2.2-8.2.4 are repeated for each test specimen of the rock type.

8.3 Block and Irregular Lump Tests :

8.3.1 Rock blocks or lumps, 30 to 85 mm, and of the shape shown in Fig. 3(*c*) and (*d*) are suitable for the block and the irregular lump tests. The ratio, D/W , should be between $\frac{1}{3}$ and 1, preferably close to 1. The distance L should be at least 0.5 W .

8.3.2 Insert a specimen in the testing machine and close the platens to make contact with the smallest dimension of the lump

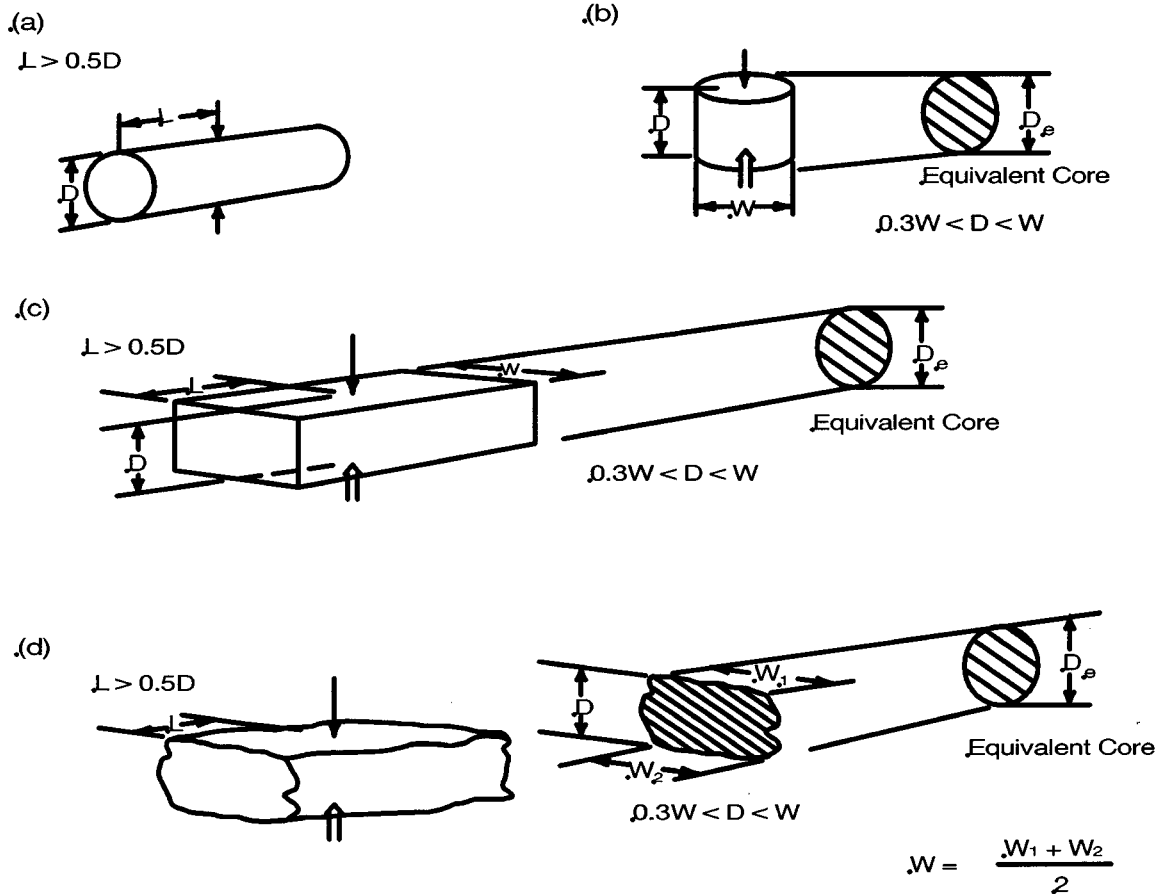

NOTE 1—Legend: L = length, W = width, D = depth or diameter, and D_e = equivalent core diameter (see 9.1).

FIG. 3 Load Configurations and Specimen Shape Requirement for (a) the Diametral Test, (b) the Axial Test, (c) the Block Test, and (d) the Irregular Lump Test⁵

or block, away from edges and corners (see Fig. 3(c) and (d)).

8.3.3 Record the distance D between platen contact points. Record the smallest specimen width, W , perpendicular to the loading direction. If the sides are not parallel, then calculate W as $(W_1 + W_2)/2$ as shown on Fig. 3. This width, W , is used in calculating point load strength index irrespective of the actual mode of failure (see Fig. 3 and Fig. 4).

8.3.4 Steadily increase the load such that failure occurs within 10 to 60 s, and record the failure load, P . The test should be rejected if the fracture surface passes through only one loading point (see examples for other shapes in Fig. 4(d) or (e)).

8.3.5 Procedures 8.3.2-8.3.4 are repeated for each test specimen in the sample.

8.4 Anisotropic Rock:

8.4.1 When a rock sample is shaley, bedded, schistose, or otherwise observably anisotropic, it should be tested in directions that will give the greatest and least strength values, in general, parallel and normal to the planes of anisotropy.

8.4.2 If the sample consists of core drilled through weakness planes, a set of diametral tests may be completed first, spaced at intervals that will yield pieces that can then be tested axially.

8.4.3 Strongest test results are obtained when the core axis is perpendicular to the planes of weakness; therefore, when possible, the core should be drilled in this direction. The angle between the core axis and the normal to the direction of least strength should preferably not exceed 30° .

8.4.4 For measurement of the point load strength index (I_s) value in the direction of least strength, ensure that load is applied along a single weakness plane. Similarly, when testing for the I_s value in the direction of greatest strength, ensure that the load is applied perpendicular to the direction of least strength.

8.4.5 If the sample consists of blocks or irregular lumps, it should be tested as two subsamples, with load first applied perpendicular to, then along the observable planes of weakness. Again, the required minimum strength value is obtained when the platens make contact and are loaded to failure along a single plane of weakness.

8.5 If significant platen penetration occurs, the dimension D to be used in calculating point load strength should be the value D' measured at the instant of failure, that will be smaller than the initial value suggested in 8.1.3, 8.2.3, and 8.3.3. The error in assuming D to be its initial value is negligible when the specimen is large or strong. The dimension at failure may always be used

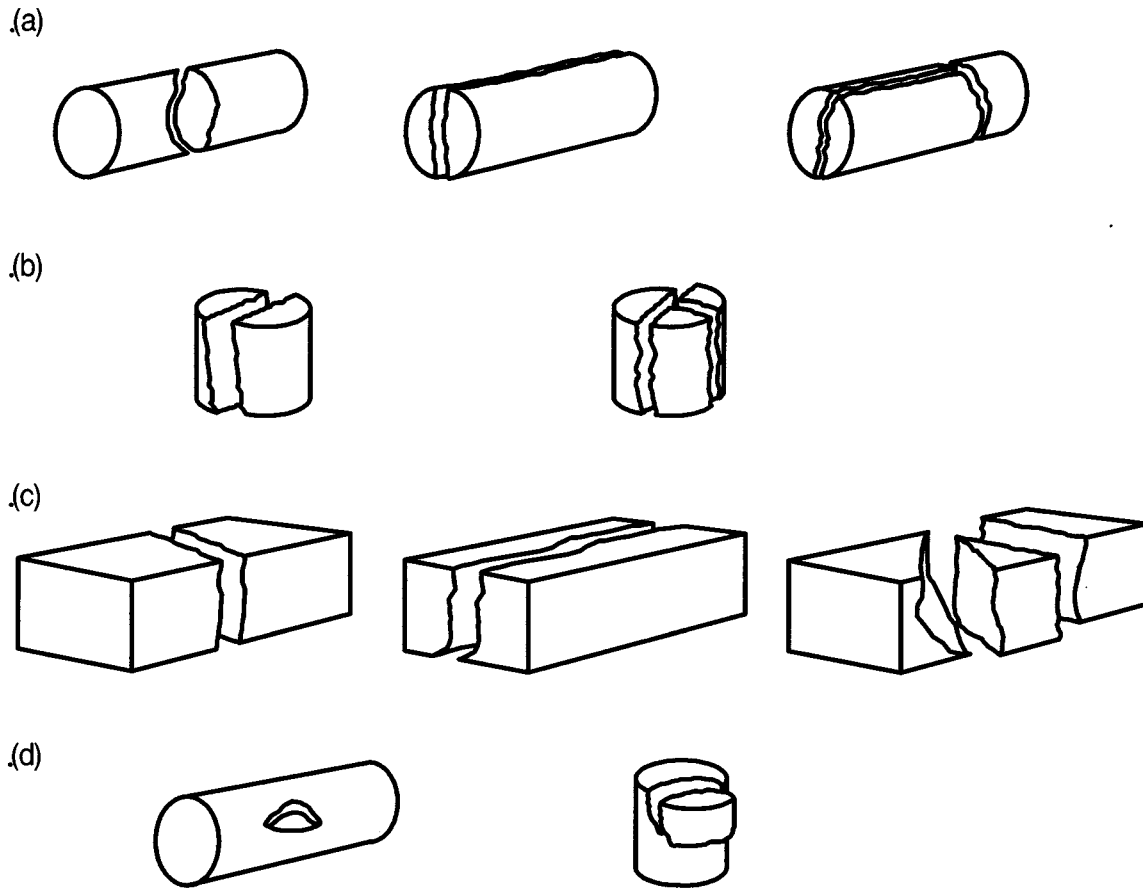

NOTE 1—(a) Valid diametral tests; (b) valid axial tests; (c) valid block tests; (d) invalid core test; and (e) invalid axial test (point load strength index test).

FIG. 4 Typical Modes of Failure for Valid and Invalid Tests⁵

as an alternative to the initial value and is preferred.

8.6 *Water Content*—Follow Test Method D 2216 to determine the water content of each rock specimen and report the moisture condition (see Section 10).

9. Calculation

9.1 *Uncorrected Point Load Strength Index*—The uncorrected point load strength I_s is calculated as:

$$I_s = P/D_e^2, \text{ MPa} \quad (1)$$

where:

P = failure load, N,

D_e = equivalent core diameter = D for diametral tests (see Fig. 3), m, and is given by:

D_e^2 = D^2 for cores, mm^2 , or

D_e^2 = $4A/\pi$ for axial, block, and lump tests, mm^2 ;

where:

A = WD = minimum cross-sectional area of a plane through the platen contact points (see Fig. 3).

NOTE 1—If significant platen penetration occurs in the test, such as when testing weak sandstones, the value of D should be the final value of the separation of the loading points, D' . Measurements of core diameter, D , or specimen width, W , made perpendicular to the line joining the loading points are not affected by this platen penetration and should be retained at the original values. The modified values of D_e can be calculated from:

$$D_e^2 = D \times D' \text{ for cores} = 4/\pi W \times D' \text{ for other shapes} \quad (2)$$

9.2 Size Correction Factor:

9.2.1 I_s varies as a function of D in the diametral test, and as a function of D_e in axial, block, and irregular lump tests, so that a size correction must be applied to obtain a unique point load strength value for the rock sample and one that can be used for purposes of rock strength classification.

9.2.2 The size-corrected point load strength index, $I_{s(50)}$, of a rock specimen is defined as the value of I_s that would have been measured by a diametral test with $D = 50$ mm.

9.2.3 When a precise rock classification is essential, the most reliable method of obtaining $I_{s(50)}$ is to conduct diametral tests at or close to $D = 50$ mm. Size correction is then unnecessary. For example, in case of diametral tests on NX, core diameter = 54 mm and size correction to $D = 50$ mm is not necessary. Most point load strength tests are in fact performed using other specimen sizes or shapes. In such cases, the size correction described in 9.2.4 or 9.2.5 must be applied.

9.2.4 The most reliable method of size correction is to test the specimen over a range of D or D_e values and to plot graphically the relation between P and D_e . If a log-log plot is used, the relation is a straight line (see Fig. 5). Points that deviate substantially from the straight line may be disregarded (although they should not be deleted). The value of $I_{s(50)}$ corresponding to $D_e^2 = 2500$ mm² ($D_e = 50$ mm) can be obtained by interpolation and use of the size-corrected point load strength index calculated as shown in 9.2.5.

9.2.5 When neither 9.2.3 nor 9.2.4 is practical (for example when testing single-sized core at a diameter other than 50 mm or if only a few small pieces are available), size correction may be accomplished using the formula:

$$I_{s(50)} = F \times I_s \tag{3}$$

The “Size Correction Factor F ” can be obtained from the chart in Fig. 6, or from the expression:

$$F = (D_e/50)^{0.45} \tag{4}$$

For tests near the standard 50-mm size, only slight error is introduced by using the approximate expression:

$$F = \sqrt{(D_e/50)} \tag{5}$$

instead of using the procedure outlined on Fig. 5.

9.3 Mean Value Calculation:

9.3.1 Mean values of $I_{s(50)}$, as defined in 9.3.2, are to be used when classifying samples with regard to their point load strength and point load strength anisotropy indices.

9.3.2 The mean value of $I_{s(50)}$ is to be calculated by deleting the two highest and two lowest values from the ten, or more, valid tests, and calculating the mean of the remaining values. If significantly fewer specimens are tested, only the highest and lowest values are to be deleted and the mean calculated from those remaining.

9.4 *Point Load Strength Anisotropy Index*—The strength anisotropy index $I_a(50)$ is defined as the ratio of mean $I_{s(50)}$ values measured perpendicular and parallel to planes of weakness, that is, the ratio of greatest to least point load strength indices. See Fig. 7⁶.

9.5 *Estimation of Compressive Strength*—The estimated uniaxial compressive strength can be obtained by using Fig. 6 or using the following formula:

⁶ D’Andrea, D.V., Fisher, R.L., and Fogelson, D.E., Prediction of Compressive Strength of Rock from Other Rock Properties, *U.S. Bureau of Mines Rep. Invest.*, 6702, 1965.

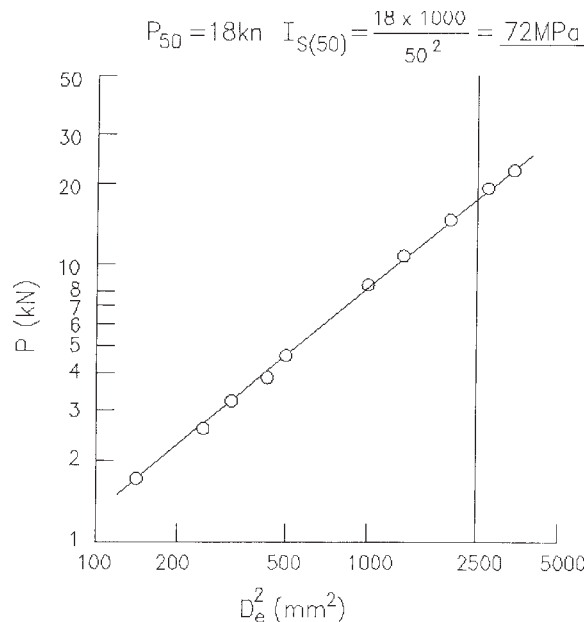

FIG. 5 Procedure for Graphical Determination of $I_{s(50)}$ from a Set of Results at D_e Values Other Than 50 mm—(ISRM-Suggested Methods)^{3, 5}

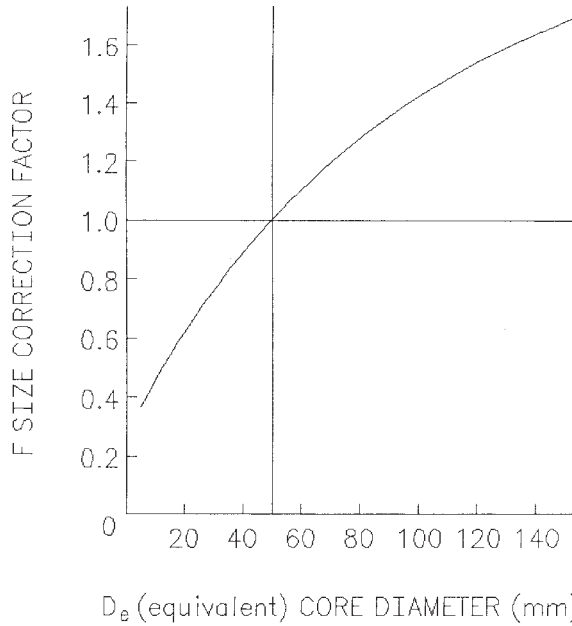

FIG. 6 Size Correction Factor Chart (ISRM Suggested Methods)⁵

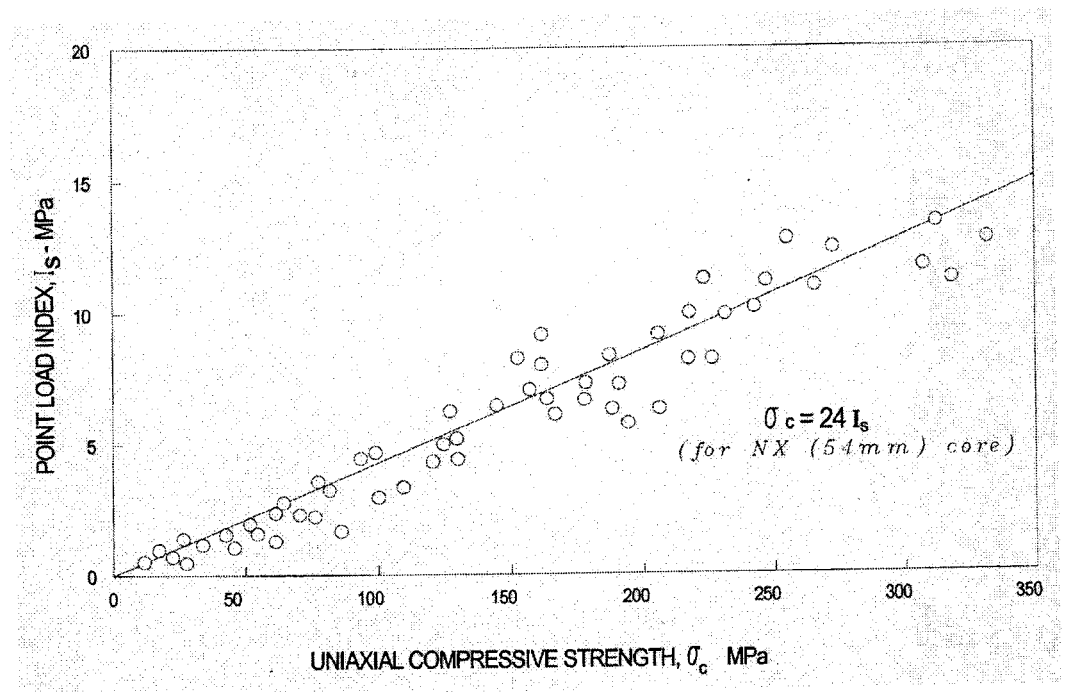

FIG. 7 Relationship Between Point Load Strength Index and Uniaxial Compressive Strength from 125 Tests On Sandstone, Quartzite, Marikana, Norite, and Belfast Norite⁶

$$\delta_{uc} = C I_{s(50)} \quad (6)$$

where:

δ_{uc} = uniaxial compressive strength,

C = factor that depends on site-specific correlation between δ_{uc} and $I_{s(50)}$, and

$I_{s(50)}$ = corrected point load strength index.

9.5.1 If exact site-specific correlation factor "C" is not available, use the generalized value of "C" shown in Table 1.

9.5.2 If any specimen in a rock type gives a value 20 % under the average, it should be examined for defects.

10. Report

10.1 A typical report (example shown in Fig. 8) may include the following:

Sample Details

Point Load Test

Date 11/17/83

1 block sample from Gamblethorpe Opencast site.

Fine grained pale grey Coal Measures sandstone with numerous coaly streaks along horizontal bedding planes.

Specimens 1-6 chisel cut blocks, air-dried 2 weeks;
 7-10 sawn blocks, air-dried 2 weeks;
 11-15 cores, air-dried 2 weeks;
 16-20 cores, air-dried 2 weeks;
 - tested in laboratory.

No.	Type	W (mm)	D(mm)	P (kN)	D _a ² (mm ²)	D _a (mm)	I _a	F	I _{a(50)}
1	i ⊥	30.4	17.2	2.687	666	25.8	4.03	0.75	
2	i ⊥	16	8	0.977	163	12.8	5.99	0.54	3.24
3	i ⊥	19.7	15.6	1.962	391	19.8	5.02	0.66	3.31
4	i ⊥	35.8	18.1	3.641	825	28.7	4.41	0.765	3.46
5	i ⊥	42.5	29	6.119	1569	39.6	3.90	0.875	3.49
6	i ⊥	42	35	7.391	1872	43.3	3.95	0.935	
7	b ⊥	44	21	4.600	1176	34.3	3.91	0.84	
8	b ⊥	40	30	5.940	1528	39.1	3.88	0.89	
9	b ⊥	19.5	15	2.040	372	19.3	5.48	0.655	
10	b ⊥	33	16	2.87	672	25.9	4.27	0.75	
11	d //	-	49.93	5.107	-	-	-	-	
12	d //	-	49.88	4.615	-	-	-	-	
13	d //	-	49.82	5.682	-	-	-	-	
14	d //	-	49.82	4.139	-	-	-	-	
15	d //	-	49.86	4.546	-	-	-	-	1.83
16	d //	-	25.23	1.837	-	-	2.89	0.74	2.14
17	d //	-	25.00	1.891	-	-	3.02	0.735	2.22
18	d //	-	25.07	2.118	-	-	3.37	0.735	
19	d //	-	25.06	1.454	-	-	2.32	0.735	
20	d //	-	25.04	1.540	-	-	2.46	0.735	1.81

d - diametral; a - axial; b - block; i - irregular lump test; ⊥ - perpendicular; // - parallel to planes of weakness.	<table border="1" style="margin-left: auto; margin-right: auto;"> <tr> <td>Mean I_{a(50)} ⊥</td> <td>3.38</td> </tr> <tr> <td>Mean I_{a(50)} //</td> <td>1.98</td> </tr> <tr> <td>I_{a(50)}</td> <td>1.71</td> </tr> </table>	Mean I _{a(50)} ⊥	3.38	Mean I _{a(50)} //	1.98	I _{a(50)}	1.71
Mean I _{a(50)} ⊥	3.38						
Mean I _{a(50)} //	1.98						
I _{a(50)}	1.71						

FIG. 8 Test Record (Point Load Strength Index)⁵

TABLE 1 Generalized Value of "C"^A

Core Size, mm	Value of "C" (Generalized)
20	17.5
30	19
40	21
50	23
54	24
60	24.5

^A From ISRM Suggested Methods.⁸⁵

10.1.1 Source of sample including project name, location, and, if known, storage environment. The location may be specified in terms of borehole number and depth of specimen from the collar of the hole,

10.1.2 Physical description of sample including rock type and location and orientation of discontinuities, such as, apparent weakness planes, bedding planes, schistosity, and large inclusions or inhomogeneities, large inclusions, if any,

10.1.3 Date of sampling and testing,

10.1.4 General indication of the moisture condition of test specimens at the time of testing, such as, saturated, as received, laboratory air dry, or oven dry. In some cases, it may be necessary to report the actual water content as determined in accordance with Test Method D 2216,

10.1.5 Average thickness and average diameter of the test specimen,

10.1.6 The maximum applied load "P",

10.1.7 The distance "D" or D', or both, if required,

- 10.1.8 Direction of loading (parallel to or normal to plane of weakness),
- 10.1.9 The number of specimens tested,
- 10.1.10 The calculated uncorrected (I_s) and corrected $I_{s(50)}$ point load strength index values,
- 10.1.11 The estimated value of uniaxial compressive strength (δ_{uc}),
- 10.1.12 The calculated value of strength anisotropy index ($I_{a(50)}$), and
- 10.1.13 Type and location of failure, including any photographs of the tested specimens before and after the test.

11. Precision and Bias

11.1 *Precision*—Due to the nature of rock materials tested by this test method, multiple specimens that have uniform physical properties have not been produced for testing. Since specimens that would yield the same test results have not been tested, Subcommittee D18.12 cannot determine the variation between tests since any variation observed is just as likely to be due to specimen variation as to operator or testing variation. Subcommittee D18.12 welcomes proposals to resolve this problem and would allow for development of a valid precision statement.

11.2 *Bias*—There is no accepted reference value for this test method; therefore, bias cannot be determined.

12. Keywords

12.1 compressive strength; index test; point load; rock

SUMMARY OF CHANGES

In accordance with Committee D18 policy, this section identifies the location of changes to this standard since the last edition (1995) that may impact the use of this standard.

- (1) Add Practice D 3740, Practice D , and Test Method E 18 to Referenced Document section.
- (2) Added Section 2.2, ISRM standard.
- (3) Added Section 3.1 referencing Terminology D 653 and renumbered subsections accordingly.
- (4) In Section 5, added a new Note 1 which references Practice D 3740 and renumbered subsequent notes.
- (5) Deleted parenthetical statement from title of Figures 1, 2, 5, and 6.
- (6) Corrected spelling of equivalent in Figures 3b, 3c, and 3d.
- (7) Corrected labeling of Figures 3c and 3d.
- (8) Added footnote 3 to Figure 3
- (9) In Section 8.4.1 corrected spelling of shaly
- (10) Redrafted Figures 4a, 4b, 4c, and 4d.
- (11) In Section 9.5.1 deleted exact from first sentence
- (12) Added missing outline numbering , 9.5.2, for last sentence in Section 9.5.1.
- (13) In Section 10.1.2, changed sentence to read”....schistosity, or large inclusions, if any.”
- (14) Deleted Note 1 from Figure 6
- (15) Corrected number in Figure 7 from 42 to 24, expanded title, deleted note, and added reference.

ASTM International takes no position respecting the validity of any patent rights asserted in connection with any item mentioned in this standard. Users of this standard are expressly advised that determination of the validity of any such patent rights, and the risk of infringement of such rights, are entirely their own responsibility.

This standard is subject to revision at any time by the responsible technical committee and must be reviewed every five years and if not revised, either reapproved or withdrawn. Your comments are invited either for revision of this standard or for additional standards and should be addressed to ASTM International Headquarters. Your comments will receive careful consideration at a meeting of the responsible technical committee, which you may attend. If you feel that your comments have not received a fair hearing you should make your views known to the ASTM Committee on Standards, at the address shown below.

This standard is copyrighted by ASTM International, 100 Barr Harbor Drive, PO Box C700, West Conshohocken, PA 19428-2959, United States. Individual reprints (single or multiple copies) of this standard may be obtained by contacting ASTM at the above address or at 610-832-9585 (phone), 610-832-9555 (fax), or service@astm.org (e-mail); or through the ASTM website (www.astm.org).