



Designation: **D 5852 – 9500**

Standard Test Method for Erodibility Determination of Soil in the Field or in the Laboratory by the Jet Index Method¹

This standard is issued under the fixed designation D 5852; the number immediately following the designation indicates the year of original adoption or, in the case of revision, the year of last revision. A number in parentheses indicates the year of last reapproval. A superscript epsilon (ϵ) indicates an editorial change since the last revision or reapproval.

1. Scope*

1.1 This test method covers the estimation of erodibility of a soil by a jet index method. This test method involves either preparing a field site or obtaining a relatively undisturbed soil sample and the subsequent activities for the determination of the erodibility of soil. This test method also may be run on compacted samples in the laboratory.

1.2 The values stated in SI units are to be regarded as the standard. The values given in parentheses are for information only.

1.3 *This standard does not purport to address all of the safety concerns, if any, associated with its use. It is the responsibility of the user of this standard to establish appropriate safety and health practices and determine the applicability of regulatory limitations prior to use.*

2. Referenced Documents

2.1 *ASTM Standards:*

¹ This test method is under the jurisdiction of ASTM Committee D-18 on Soil and Rock and is the direct responsibility of Subcommittee D18.02 on Sampling and Related Field Testing for Soil Evaluations.

Current edition approved Oct. 10, 1995; 2000. Published December 1995. February 2000. Originally published as D 5852 – 95. Last previous edition D 5852 – 95.

***A Summary of Changes section appears at the end of this standard.**

- D 420 Guide to Site Characterization for Engineering, Design, and Construction Purposes²
- D 653 Terminology Relating to Soil, Rock, and Contained Fluids²
- D 2216 Test Method for Laboratory Determination of Water (Moisture) Content of Soil and Rock²
- D 2488 Practice for Description and Identification of Soils (Visual-Manual Procedure)²
- D 374220 Practice for ~~Preserving and Transporting~~ Minimum Requirements for Agencies Engaged in the Testing and/or Inspection of Soil Samples and Rock as Used in Engineering Design and Construction²
- D 4220 Practices for Preserving and Transporting Soil Samples²
- D 4753 Specification for Evaluating, Selecting, and Specifying Balances and Scales for Use in Testing Soil, Rock, and Related Construction Materials²

3. Significance and Use

3.1 Water flow in nature exerts a force on soils that results in erosion. Erosion potential of a soil is of concern in vegetated channels, road embankments, dams, levees, spillways, construction sites, etc. The jet index method is intended to provide a standard method of expressing erosion resistance; to assist those who work with different soils and soil conditions to measure erosion resistance for design purposes; and to provide a Terminology

3.1 Definitions:

3.1.1 For common system of characterizing soil properties to develop performance and prediction relationships.

3.2 The jet index test is not suited for determining erodibility of soils that have structure characteristics larger than the scale of the jet testing device. For example, the erodibility of soil that has a dominant soil structure of 7 to 8 cm or larger (that is, aggregate, clod, or particle size), that might play a key role in the detachment process, should not be estimated with the jet index test. Care should be taken that the test sample and test is representative definitions of expected conditions at the site under investigation. If it is known terms in advance that the soil will be saturated prior this standard, refer to an erosion event, then the soil should be tested in that condition. At present, the effects of water chemistry on detachment rate are unknown. Therefore, water quality during testing should be simulated as close as possible to the water quality anticipated during actual erosion. Terminology D 653.

4. Significance and Use

4.1 Water flow in nature exerts a force on soils that results in erosion. Erosion potential of a soil is of concern in vegetated channels, road embankments, dams, levees, spillways, construction sites, etc. The jet index method is intended to provide a standard method of expressing erosion resistance; to assist those who work with different soils and soil conditions to measure erosion resistance for design purposes; and to provide a common system of characterizing soil properties to develop performance and prediction relationships.

4.2 The jet index test is not suited for determining erodibility of soils that have structure characteristics larger than the scale of the jet testing device. For example, the erodibility of soil that has a dominant soil structure of 7 to 8 cm or larger (that is, aggregate, clod, or particle size), that might play a key role in the detachment process, should not be estimated with the jet index test. Care should be taken that the test sample and test are representative of expected conditions at the site under investigation. If it is known in advance that the soil will be saturated prior to an erosion event, then the soil should be tested in that condition. At present, the effects of water chemistry on detachment rate are unknown. Therefore, water quality during testing should be simulated as close as possible to the water quality anticipated during actual erosion.

NOTE 1—The quality of the result produced by this standard is depend upon the competence of the personnel performing it, and the suitability of the equipment and facilities used. Agencies that meet the criteria of Practice D 3740 are generally considered capable of competent and objective testing and sampling. Users of this standard are cautioned that compliance with Practice D 3740 does not in itself assure reliable results. Reliable results depend on many factors; Practice D 3740 provides a means of evaluating some of those factors.

5. Apparatus

45.1 Field Testing:

45.1.1 *Vertical Submerged Jet Device*— An apparatus that can be taken to the field to index soil erodibility (see Fig. 1). The device is mounted on a base ring with a sealing ring to prevent leakage and piping. A cylindrical tank is attached to the base ring to act as a weir while maintaining the water level required to submerge the jet. The soil surface inside the device is 0.44 m in diameter. Attached to the tank is an inner cylindrical liner that acts as a baffle to minimize return turbulence to the jet. The jet and pin profiler (see Fig. 2 and Fig. 3) are interchangeable and are mounted to the upper surface of this liner. A 51-mm diameter clear acrylic tube, the lower end of which is fitted with a 13-mm diameter nozzle, is mounted in a hanger that can be set on the inner cylindrical liner.

NOTE 12—Detailed drawings of the apparatus and supporting equipment are available from ASTM Headquarters.

45.1.2 *Pin Profiler*, used to determine the maximum depth of material removed during testing.

² Annual Book of ASTM Standards, Vol 04.08.

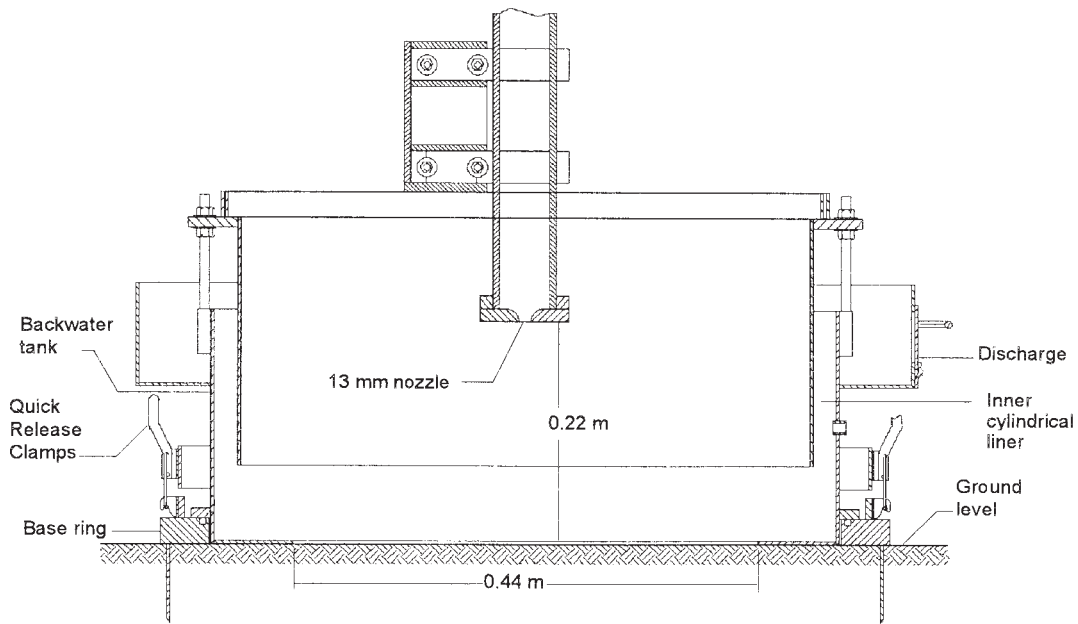

FIG. 1 Submerged Jet Apparatus for Field Testing



FIG. 2 Jet Apparatus in Operation

45.1.3 *Water Delivery System*, required to run the jet test. Water delivery may be accomplished by pumping directly from a body of water at the site, from a storage tank delivered to the site, or from a city water supply system if available.

45.1.4 *Differential Pressure Device*, necessary in order to determine the mean velocity at the jet nozzle. This may be accomplished by manometers, differential pressure gage, or pressure transducer.

45.1.5 *Pressure Control*, necessary to maintain a constant velocity at the jet nozzle. This may be accomplished by a constant head tank or a valve.

45.1.6 *Level*—A carpenter's level is necessary to level the foundation ring and inner liner of the tank.

45.1.7 *Shovel*—A flat-nosed shovel is useful in preparing the site for testing.

45.1.8 *Ruler*—A ruler is required to set the jet nozzle at a height of 0.22 m above the unscoured soil surface.

45.1.9 *Miscellaneous Equipment*—A 10 to 13 cm diameter flat disk, sledgehammer, wrenches, plastic bags and other soil sampling equipment for other soil tests of interest.

45.2 *Laboratory Testing:*

45.2.1 *Vertical Submerged Jet Device*— An apparatus that can be used in the laboratory to determine soil erodibility (see Fig. 4). The device consists of a lower cylindrical tank that slides under a fixed upper cylindrical tank. The upper and lower cylindrical tanks are sealed together with an inflated tube to prevent leakage during testing. The sample is loaded into the lower tank and slid under the upper tank. The upper tank acts as a weir while maintaining the water level required to submerge the jet. The soil samples are contained in pvc molds with an inner diameter of 0.44 m and a height of 0.18 m. Attached to the tank is an inner cylindrical liner that acts as a baffle to minimize return turbulence to the jet. The jet and pin profiler are interchangeable, mounted to the upper

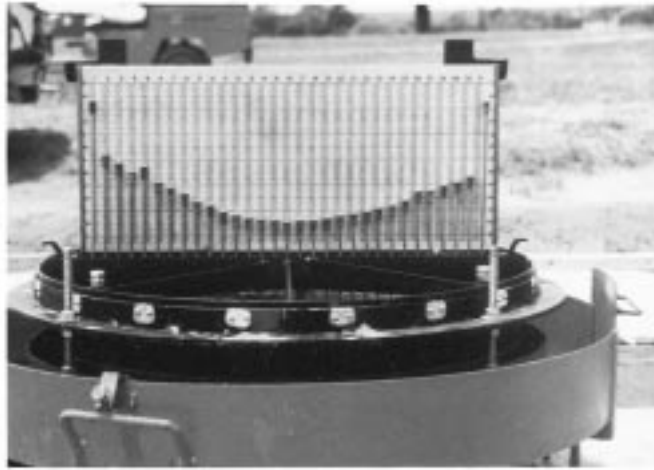

FIG. 3 Pin Profile Following a Time Sequence

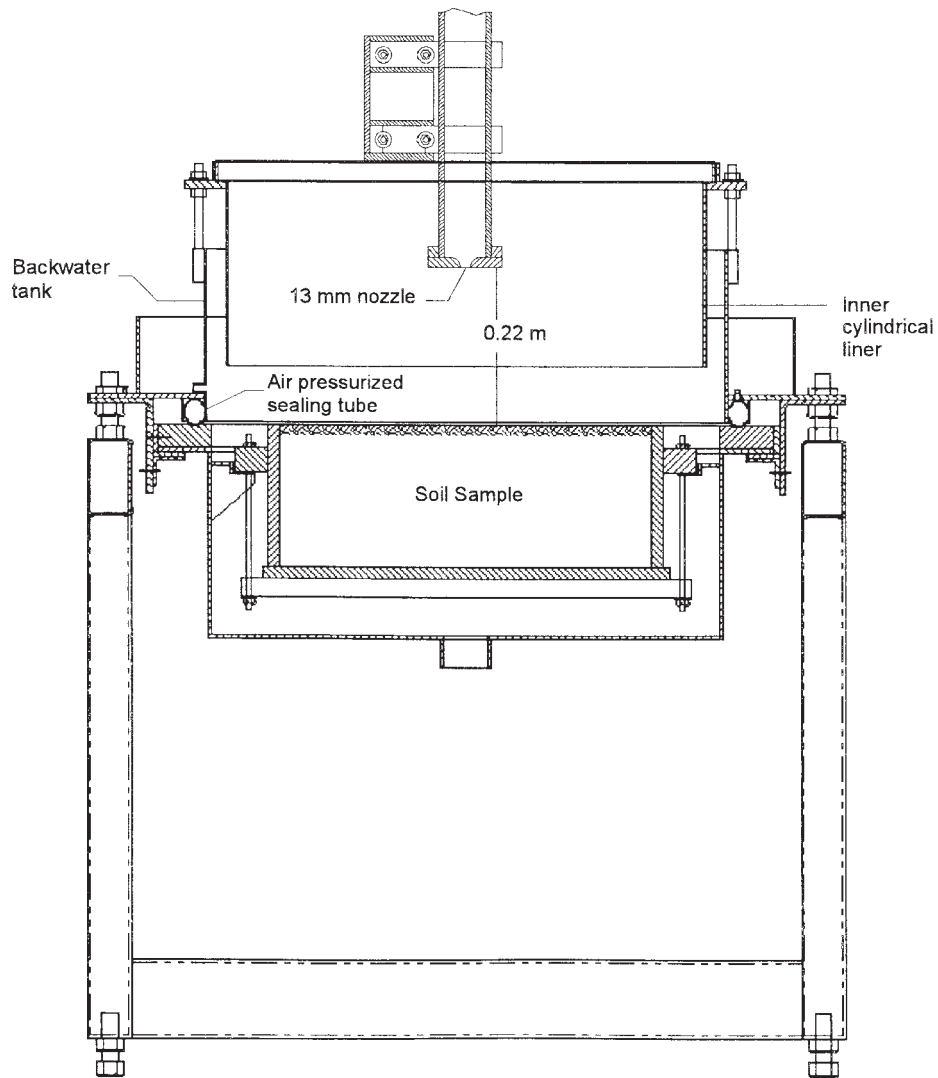

FIG. 4 Submerged Jet Apparatus for Laboratory Testing

surface of this liner. A 51-mm diameter clear acrylic tube, the lower end of which is fitted with a 13-mm diameter nozzle, is mounted in a hanger that can be set on the inner cylindrical liner.

45.2.2 *Mold*—A large mold is required for obtaining relatively undisturbed samples from the field. Due to the size of the

samples required, ~~it is recommended that pvc molds be used~~ are recommended to minimize the mass of the sample. The mold size recommended consists of 0.44 m inner diameter and 0.18 m height. Once a mold sample is obtained in the field, it should be immediately covered at both ends with stiff plastic disks held firmly with a framing system. Sampling and preserving/transporting soils samples ~~will be~~ are done in accordance with Guide D 420 and Practice 4220 respectively.

45.2.3 *Cutting Head*—A cutting head is essential for taking samples this size in the field. The cutting head ~~should be~~ is mounted to the front end of the mold and driven in or pushed in advance of the mold. The procedure for obtaining a sample is to advance the mold and cutting head 5 to 8 cm at a time, remove the material around the outside of the mold and repeat the process until the mold is to the desired depth.

45.2.4 *Straight Edge*—A straight edge is necessary to trim both ends of the sample flush with the mold.

45.2.5 *Shovel*—Any one of several types of shovels or spades is satisfactory for shallow sampling when digging around the mold.

45.2.6 *Balances*—All balances ~~must~~ shall meet the requirements of Specification D 4753 and this section. A balance or scale of at least 100 kg capacity is required for determining the mass of the mold and sample. A balance or scale of 500 g capacity is required to determine field water content of disturbed samples.

45.2.7 *Drying Equipment*—Equipment and oven are required to determine water content. Water contents shall be determined in accordance with Test Method D 2216.

45.2.8 *Water Delivery System, Differential Pressure Device, and Pressure Control*—Equipment necessary for water delivery, differential pressure control and measurement are necessary for both the laboratory device and for the field testing device.

45.2.9 *Miscellaneous Equipment*—A 10 to 13 cm diameter flat disk, sledgehammer, plastic bags, cans, gloves, wrenches and ruler.

56. Procedure

56.1 Field Testing:

56.1.1 Prepare the surface at the test location so that it is reasonably level and void of vegetation. When the site is ready for testing, push the base ring into the soil. This may require the use of a sledgehammer, impacting on a wood cushion (such as a two by four) to protect the base ring from damage. The base ring should then be checked to make sure it is relatively level.

56.1.2 Set the backwater tank in place over the base ring and latch down. Place the cylindrical liner on the leveling bolts of the backwater tank and level. Use the pin profiler to determine the pre-testing soil elevation. Pre-set the head on the jet device so that only minor nozzle adjustments are necessary at the beginning of the test. Do this by placing it in a 5 gal (18.9 (about 19 L) bucket near the same elevation as the backwater tank and make necessary adjustments to the head differential on the nozzle. Although other head settings may be used, the recommended head setting on the jet is 0.91 m (36 in.). Remove the pin profiler and backfill the tank with water. Place the jet apparatus on the backwater tank cylindrical liner. Hold a flat 10 to 13 cm diameter disk approximately 3 cm from the nozzle outlet and make final adjustments to the head. The flat disk prevents discharge from the nozzle from impinging directly on the sample prior to testing. Remove the disk from the discharging jet to initiate testing. A timing sequence of 600, 1200, 1800, and 3600 s intervals is recommended for a total testing time of 7200 s. Other timing sequences are at the discretion of the user. A pin profile of the surface of the tested soil sample ~~is to~~ shall be taken after each time sequence (see Fig. 3). Following testing, equipment clean up is essential.

56.1.3 Before testing, the inner cylinder should be made level and the nozzle jet height should be set at 0.22 m above the surface of the soil sample. Before testing begins, the fluid head on the jet should be set close to 0.91 m so that only minor adjustments are necessary at start up of testing.

56.2 Laboratory Testing:

56.2.1 Pre-set the head on the jet device. Load the sample into the lower tank and slide the sample under the upper tank. Pressurize the sealing tube between the upper and lower cylinders of the testing apparatus.

56.2.2 Use the pin profiler to determine the pretesting soil elevation. Remove the pin profiler and backfill the tank with water. Place the jet apparatus on the backwater tank cylindrical liner. Hold a flat 10 to 13 cm diameter disk approximately 3 cm from the nozzle outlet and make final adjustments to the head. The flat disk prevents discharge from the nozzle from impinging directly on the sample prior to testing. Remove the disk from the discharging jet to initiate testing. A test timing sequence of 600, 1200, 1800, and 3600 s intervals is recommended for a total testing time of 7200 s. Other timing sequences are at the discretion of the user. A pin profile of the surface of the tested soil sample ~~is to~~ shall be taken after each time sequence. Following testing, equipment clean up is essential.

56.2.3 Before testing, the inner cylinder should be made level and the nozzle jet height should be set at 0.22 m above the surface of the soil sample. Before testing begins, the fluid head on the jet should be set close to 0.91 m so that only minor adjustments are necessary at start up of testing.

67. Calculation

67.1 Calculate the velocity of the jet at the nozzle:

$$U_o = C\sqrt{2gh} \quad (1)$$

where:

- U_o = velocity of the jet at the nozzle (cm/s),
- g = acceleration due to gravity (981 cm/s²),
- h = head on the jet (cm), and
- C = nozzle coefficient.

A rounded nozzle is used in this apparatus (see the detailed plans). Therefore, a nozzle coefficient of one may be assumed.

67.2 Determine the maximum depth of scour for each time interval (see Fig. 3):

$$D = \frac{\sum_i \sum_{p=15}^{17} (R_{pt} - R_{p0})}{n} \tag{2}$$

where:

- D_s = average maximum depth of scour determined from profile pins 15, 16, and 17 for each profile reading taken for each time sequence (cm),
- i = number of profiles read (cm),
- p = pin numbers of interest,
- R_{p0} = pin reading at time 0 (cm),
- R_{pt} = pin reading for the time sequence of interest (cm), and
- n = total number of pin readings ($i \times 3$).

67.3 Determine the jet index by plotting D_s/t versus

$U_o(t)^{-0.931}$ with t in seconds.³ D_s should be measured to the nearest 1 mm, t to 1s, and U_o to 1 cm/sec. The slope of the line, passing through zero, created by a least squares fit of the data is the jet index (see Fig. 5). If the sample scours to the depth of the sample in the first time sequence of testing (600 s), the slope of the line through zero and the single resulting point results in an estimate of the jet index. Based on experience, typical values of the jet index ranges from 0 to 0.03 with a value of 0.001, 0.01, and 0.02 indicating high resistance, moderate resistance, and low resistance to erosion, respectively.³

67.4 The jet index is an erosion performance index. If an estimate of the erodibility is desired, further calculations are required. Typically, erosion in an open channel ~~has been~~ is expressed as a relationship between the erosion rate and mean effective stress in excess of some critical stress:

$$\epsilon = k(\tau_e - \tau_c) \tag{3}$$

³ Hanson, G. J., "Development of a Jet Index to Characterize Erosion Resistance of Soils In Earthen Spillways," *Transactions of the American Society of Agricultural Engineers*, Vol 34, No. 5, 1991, pp. 2015–2020.

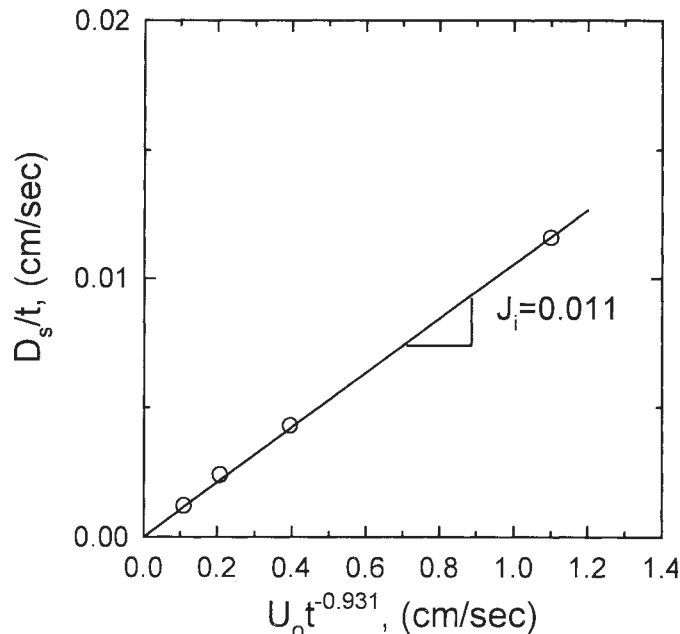

FIG. 5 Plot D_s/t Versus $U_o t^{-0.931}$ With J_i as the Slope of a Least Squares Fit Line Passing Through the Origin

where:

- k = erodibility coefficient (cm³/N-s),
- τ_e = effective stress on the soil boundary (N/cm²),
- τ_c = critical stress (N/cm²), and
- ϵ = erosion rate (cm/s).

If the critical tractive stress is assumed to be small relative to the effective stress, effectively zero, an estimate of the erodibility coefficient may be is made based on the following equation:³

$$k = 0.003e^{385J_i} \quad (4)$$

where:

- k = erodibility coefficient cm³/N-s, and
- J_i = jet index.

7. Report

7.1 Report the following items:

- ~~7.1.1 Whether the test was conducted in the field or in the laboratory;~~
- ~~7.1.2 Location where test was run or where sample was taken from;~~
- ~~7.1.3 Depth below the ground surface or elevation of surface, or both;~~
- ~~7.1.4 If a laboratory test was performed, the dimensions and volume of the sample should be given;~~
- ~~7.1.5 The water content and unit weight of the sample should be determined;~~
- ~~7.1.6 Visual description of the soil sample in accordance with Practice D 2488, and also how it eroded (that is, by particle or by aggregate, and uniform or irregular scour hole);~~
- ~~7.1.7 Comments on sample or site disturbance and other important items; and~~
- ~~7.1.8 Jet index test results.~~

8. Precision and Bias

~~8.1 The precision and bias of this Report~~

~~8.1 Report the following items:~~

- ~~8.1.1 Whether the test method for measuring soil erodibility by was conducted in the jet index method has not been determined. No available methods provide absolute values for field or in the soil erodibility coefficient against which this laboratory;~~
- ~~8.1.2 Location where test method can be compared. This test method has been compared against results was run or where sample was taken from;~~
- ~~8.1.3 Depth below the ground surface or elevation of open channel surface, or both;~~
- ~~8.1.4 If a laboratory test results, but was performed, include the variability of soil dimensions and the destructive nature volume of this test method do not allow for repetitive duplication of test results required to obtain meaningful statistical evaluation. Precision is a function of the care exercised in performing the steps sample;~~
- ~~8.1.5 The water content and unit weight of the test method given, with attention to systematic repetition sample;~~
- ~~8.1.6 Visual description of the procedure soil sample in accordance with Practice D 2488, and also how it equeroded (that is, by particle or by aggregate, and uniform or irregular scour hole);~~
- ~~8.1.7 Comment ms on sample or site disturbance and other important items; and~~
- ~~8.1.8 Jet index test results.~~

9. Precision and Bias

9.1 Precision—The precision and bias of this test method for measuring soil erodibility by the jet index method has not been determined. No available methods provide absolute values for the soil erodibility coefficient against which this test method can be compared. This test method has been compared against results of open channel test results, but the variability of soil and the destructive nature of this test method do not allow for repetitive duplication of test results required to obtain meaningful statistical evaluation. Precision is a function of the care exercised in performing the steps of the test method given, with attention to systematic repetition of the procedure and equipment maintenance.

9.2 Bias—There is no accepted reference value for this test method, therefore bias cannot be determined.

10. Keywords

- 9.1 erosion; in-situ;
- 10.1 erosion; jet; soil; water

SUMMARY OF CHANGES

In accordance with Committee D18 policy, this section identifies the location of changes to this standard since the last edition, 1995, that may impact the use of this standard;

- (1) Added D 653 and D 3740 to Section Referenced Documents.
- (2) Added Note 1 in reference to D 3740 for evaluating competent operators.
- (3) Added section Terminology.
- (4) Added sentence to 7.3 explaining to what number of significant digits each data element is recorded and calculated.

ASTM International takes no position respecting the validity of any patent rights asserted in connection with any item mentioned in this standard. Users of this standard are expressly advised that determination of the validity of any such patent rights, and the risk of infringement of such rights, are entirely their own responsibility.

This standard is subject to revision at any time by the responsible technical committee and must be reviewed every five years and if not revised, either reapproved or withdrawn. Your comments are invited either for revision of this standard or for additional standards and should be addressed to ASTM International Headquarters. Your comments will receive careful consideration at a meeting of the responsible technical committee, which you may attend. If you feel that your comments have not received a fair hearing you should make your views known to the ASTM Committee on Standards, at the address shown below.

This standard is copyrighted by ASTM International, 100 Barr Harbor Drive, PO Box C700, West Conshohocken, PA 19428-2959, United States. Individual reprints (single or multiple copies) of this standard may be obtained by contacting ASTM at the above address or at 610-832-9585 (phone), 610-832-9555 (fax), or service@astm.org (e-mail); or through the ASTM website (www.astm.org).