



## Standard Test Methods for Frost Heave and Thaw Weakening Susceptibility of Soils<sup>1</sup>

This standard is issued under the fixed designation D 5918; the number immediately following the designation indicates the year of original adoption or, in the case of revision, the year of last revision. A number in parentheses indicates the year of last reapproval. A superscript epsilon ( $\epsilon$ ) indicates an editorial change since the last revision or reapproval.

### 1. Scope

1.1 These laboratory test methods cover the frost heave and thaw weakening susceptibilities of soil that is tested in the laboratory by comparing the heave rate and thawed bearing ratio<sup>2</sup> with values in an established classification system. This test was developed to classify the frost susceptibility of soils used in pavements. It should be used for soils where frost-susceptibility considerations, based on particle size such as the limit of 3 % finer than 20 mm in Specification D 2940, are uncertain. This is most important for frost-susceptibility criteria such as those used by the Corps of Engineers,<sup>3</sup> that require a freezing test for aggregates of inconclusive frost classification. The frost heave susceptibility is determined from the heave rate during freezing. The thaw weakening susceptibility is determined with the bearing ratio test (see Test Method D 1883).

1.2 This is an index test for estimating the relative degree of frost-susceptibility of soils used in pavement systems. It cannot be used to predict the amount of frost heave nor the strength after thawing, nor can it be used for long-term freezing of permafrost or for foundations of refrigerated structures.

1.3 The test methods described are for one sample and uses manual temperature control. It is suggested that four samples be tested simultaneously and that the temperature control and data taking be automated using a computer.

1.4 The values stated in SI units are to be regarded as the standard. The inch-pound units given in parentheses are for information only.

1.5 *This standard does not purport to address all of the safety concerns, if any, associated with its use. It is the responsibility of the user of this standard to establish appropriate safety and health practices and determine the applicability of regulatory limitations prior to use.*

<sup>1</sup> These test methods are under the jurisdiction of ASTM Committee D-18 on Soil and Rock and are the direct responsibility of Subcommittee D18.19 on Frozen Soils and Rock.

Current edition approved March 10, 1996. Published June 1996.

<sup>2</sup> Sometimes called California Bearing Ratio (CBR).

<sup>3</sup> The Army Corps of Engineers uses a frost susceptibility classification procedure (TM 5-818-2) based on particle size criteria and the Unified Soil Classification System (MIL-STD-619) field. Furthermore, this test should only be used for seasonal freezing and thawing conditions and not for long-term freezing of permafrost or of foundations of refrigerated structures.

### 2. Referenced Documents

#### 2.1 ASTM Standards:

C 702 Methods for Reducing Field Samples of Aggregate to Testing Size<sup>4</sup>

D 75 Practice for Sampling Aggregates<sup>5</sup>

D 420 Practice for Investigating and Sampling Soil and Rock for Engineering Purposes<sup>6</sup>

D 653 Terminology Relating to Soil, Rock, and Contaminated Fluids<sup>6</sup>

D 698 Laboratory Compaction Characteristics of Soil Using Standard Effort [12 400 ft-lbf/ft<sup>3</sup> (600 kN-m/m<sup>3</sup>)]<sup>6</sup>

D 1587 Practice for Thin-Walled Tube Sampling of Soils<sup>6</sup>

D 1883 Test Method for Bearing Ratio of Laboratory-Compacted Soils<sup>6</sup>

D 2216 Method for Laboratory Determination of Water (Moisture) Content Soil, Rock, and Soil-Aggregate Mixtures<sup>6</sup>

D 2940 Specification for Graded Aggregate Material for Bases or Subbases for Highways or Airports<sup>6</sup>

D 3550 Practice for Ring-Lined Barrel Sampling of Soils<sup>6</sup>

D 4083 Practice for Description of Frozen Soils (Visual-Manual Procedure)<sup>6</sup>

E 105 Practice for Probability Sampling of Soils<sup>4</sup>

E 122 Practice for Choice of Sample Size to Estimate the Average Quality of a Lot or Process<sup>4</sup>

#### 2.2 Military Standards:

Army TM 5-818-2 Pavement Design for Frost Conditions, January 1985<sup>7</sup>

MIL-STD-619 Unified Soil Classification System for Roads, Airfields, Embankments and Foundations<sup>7</sup>

### 3. Terminology

#### 3.1 Definitions:

3.1.1 Definitions of the soil components of a freezing and thawing soil system shall be in accordance with the terminology in Terminology D 653.

3.1.2 Definitions of the components of freezing and thawing soils shall be in accordance with the terminology in Practice D 4083.

<sup>4</sup> Annual Book of ASTM Standards, Vol 04.02.

<sup>5</sup> Annual Book of ASTM Standards, Vols 04.02, 04.03, and 04.08.

<sup>6</sup> Annual Book of ASTM Standards, Vol 04.08.

<sup>7</sup> Available from Superintendent of Documents, U.S. Government Printing Office, Washington, DC 20402.

3.1.3 The following terms are used in conjunction with the determination of the frost-susceptibility of soils and supplement those in Practice D 4083 and in the glossary on permafrost terms by Harris et al.<sup>8</sup>

3.1.3.1 *degree of frost-susceptibility*—the relative propensity for frost heave or thaw weakening in comparison to that for another soil or to an acceptable level of change.

3.1.3.2 *freeze-thaw cycling*—the repeated freezing and thawing of soil.

3.1.3.3 *freezing (soil)*—the changing of phase from water to ice in soil.

3.1.3.4 *freezing, closed system*—freezing that occurs under conditions that preclude the gain or loss of any water in the system.

3.1.3.5 *freezing, open system*—freezing that occurs under conditions that allow gain or loss of water in the system by movement of pore water from or to an external source to growing ice lenses.

3.1.3.6 *freezing-point depression*—the number of degrees by which the freezing point of an earth material is depressed below the freezing point of pure water.

3.1.3.7 *frost heave*—the upward or outward movement of the ground or pavement surface (in the direction of heat flow) caused by the formation of ice in the soil.

3.1.3.8 *frost heave rate*—the rate at which the ground or pavement surface moves upward or outward.

3.1.3.9 *frost heave susceptibility*—the propensity for a soil to accumulate ice during freezing and to heave.

3.1.3.10 *frost-susceptible soil*—soil in which ice accumulation causes frost heave during freezing or thaw weakening during thawing, or both.

3.1.3.11 *ice lens*—a lens-shaped body of ice of any dimension that forms during unidirectional freezing of soil, the long dimension being in the direction normal to the direction of heat flow.

3.1.3.12 *ice nucleation*—the formation of an ice nucleus from water.

3.1.3.13 *refrigerated structures*—artificially refrigerated structures (cold storage facilities, liquefied gas tanks, ice skating rinks, chilled gas pipelines, and so forth) that cause the freezing of their foundations.

3.1.3.14 *relative frost susceptibility*—the amount of frost heave or thaw weakening of a soil in relation to other soils.

3.1.3.15 *seasonally frozen ground*—ground that freezes and thaws annually.

3.1.3.16 *thaw weakening*—the reduction in strength, bearing capacity, or stiffness modulus below the normal warm-season values. This is caused by the decrease in effective stress resulting from the generation and slow dissipation of excess pore water pressures when frozen soils containing ice are thawing.

3.1.3.17 *thaw weakening susceptibility*—the propensity for the strength or stiffness modulus of a soil to decrease below the

normal warm season values.

3.1.3.18 *unidirectional freezing*—soil freezing that occurs in one direction only.

#### 4. Summary of Test Methods

4.1 Two freeze-thaw cycles are imposed on compacted soil samples, 146 mm (5.75 in.) in diameter and 150 mm (6 in.) in height. The soil sample is frozen and thawed by applying specified constant temperatures in steps at the top and bottom of the sample, with or without water freely available at the base; a surcharge of 3.5 kPa (0.5 lbf/in.) is applied to the top. The temperatures imposed on the sample are adjusted to take into account the freezing point depression attributable to salts in the soil. At the end of the second thawing cycle, the bearing ratio is determined. The entire testing procedure can be completed within a five-day period. This testing procedure may be conducted manually or it may be controlled by a computer.

#### 5. Significance and Use

5.1 These test methods can be used to determine the relative frost-susceptibility of soils used in pavement systems. Both the frost heave susceptibility and the thaw weakening susceptibility can be determined.

5.2 These test methods should be used only for seasonal frost conditions and not for permanent or long-term freezing of soil. These test methods also have not been validated for anything other than pavement systems.

5.3 These test methods cannot be used to predict the amount of frost heave or thaw weakening in the field. Its purpose is to determine the relative frost-susceptibility classification for use in empirical pavement design methods for seasonal frost regions.

#### 6. Apparatus

6.1 *Compaction Mold*—The mold assembly (see Fig. 1) shall consist of a steel base plate, a steel hollow cylinder split

longitudinally, two acrylic spacer disks, six acrylic rings, a steel collar, a rubber membrane, and four hose clamps.

6.1.1 *Base Plate*—A 203-mm (8-in.) square steel base plate (see Fig. 1) with a thickness of 25 mm (1.0 in.) and a 6.0-mm (0.25-in.) recess to receive and retain the steel side walls and base of the sample. Two 9.5-mm (0.375-in.) diameter threaded holes at opposite corners accommodate clamping rods.

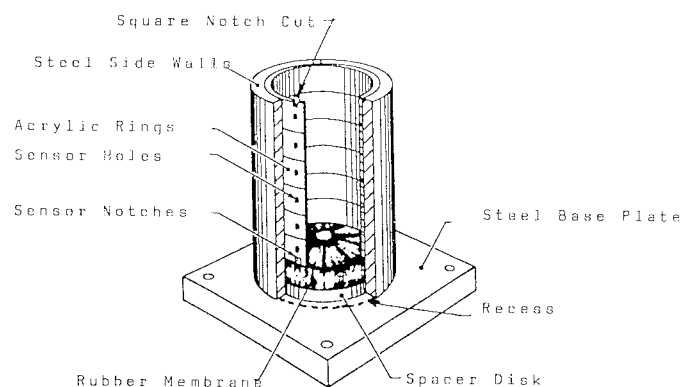

FIG. 1 Compaction Mold Assembly

<sup>8</sup>Harris, S. A. et al, *Glossary of Permafrost and Related Ground-Ice Terms*, Permafrost Subcommittee, Associate Committee on Geotechnical Research, National Research Council of Canada, Technical Memorandum No. 142, Available from National Research Council of Canada, Ottawa, Ontario, Canada, K1A0R6, 1988.

6.1.2 *Compaction Cylinder*—A hollow steel cylinder with an inside diameter of 152.4 mm (6 in.), a wall thickness of 9.5 mm (0.375 in.), and a length of 165.1 mm (6.5 in.). The cylinder is to be made in three sections that part along the vertical axis (see Fig. 1). A recess in the steel base plate accepts the steel cylinder and restrains it from expanding during compaction.

6.1.3 *Collar*—A steel collar with a 146-mm (5.75-in.) inside diameter and a 185-mm (7.25-in.) outside diameter with a 152.4-mm (6-in.) diameter recess bored 6.35 mm (0.25 in.) into the bottom. This collar slips over the top of the steel mold to constrain expansion and to provide extra space for soil during compaction. Flanges slide over the steel rods to hold the collar in place.

6.1.4 *Spacer Disk*—Two circular acrylic spacer disks (see Fig. 1), 158.8 mm (6.25 in.) in diameter and 6.4 mm (0.25 in.) in height. One spacer disk is placed at the bottom of the compaction mold. The second disk is placed on the top of the sample during transport and storage.

6.1.5 *Rings*—Six acrylic rings (see Fig. 1 and Fig. 2) having an inside diameter of 146 mm (5.75 in.) and a height of 25 mm (1 in.) with a wall thickness of 3.18 mm (0.125 in.). A 3.18-mm diameter hole shall be drilled at the midheight in each ring to receive a temperature sensor. The top and bottom rings shall have a 3.18-mm square notch cut in one edge to receive the top and bottom temperature sensor leads. Each ring shall have a split cut through its height at a location diametrically opposite the temperature sensor hole.

6.1.6 *Clamping Rods*—Two 9.5-mm (0.375-in.) diameter by 215.9-mm (8.5-in.) long threaded steel rods with two wing nuts to clamp the assembly together.

6.1.7 *Rubber Membrane*—A 0.36-mm (0.014-in.) thick rub-

ber membrane without holes or defects. This is required to seal the sides of a soil sample that shall be 146.0 mm (5.25 in.) in diameter. The length of the membrane shall be at least 203.0 mm (8.0 in.).

6.1.8 *Clamps*—Four hose clamps to hold the steel side walls together. The outside diameter of the side walls are to be 168.0 mm (6.75 in.).

6.2 *Sample Freezing Assembly*—The apparatus for freezing the soil sample (see Fig. 2) shall consist of temperature-controlled top and bottom plates, a sample base plate with a porous stone and two ports for water supply and flushing (filter paper is placed between the stone and the sample bottom), six acrylic rings stacked to form a cylinder and a rubber membrane to contain the soil sample, a temperature-controlled top plate; a surcharge weight, a constant head (Mariotte) water supply, an assembly to support the displacement measuring system, and a displacement transducer or dial extensometer, or both.

6.2.1 *Top and Bottom Temperature Control End Plates*—The temperature control end plates (see Fig. 2) shall be fabricated from reinforced phenolic resin, with an aluminum plate cover to provide heat-conductive surfaces contiguous to the top of the soil sample and to the bottom of the base plate. The phenolic resin component of the end plates shall be machined so that the cooling (or heating) liquid entering each end plate shall follow a serpentine path and exit at a point diametrically opposite the entrance point.

6.2.2 *Sample Base Plate*—The circular aluminum base plate (see Fig. 2) is to be 150 mm (6 in.) in diameter and 38 mm (1.5 in.) in height. The top of the base plate is to have two concentric circular recesses in its top surface to hold a circular porous stone or a stainless steel porous disk. One recess is to be 138.1 mm (5.4 in.) in diameter and have a depth of 6 mm (0.25

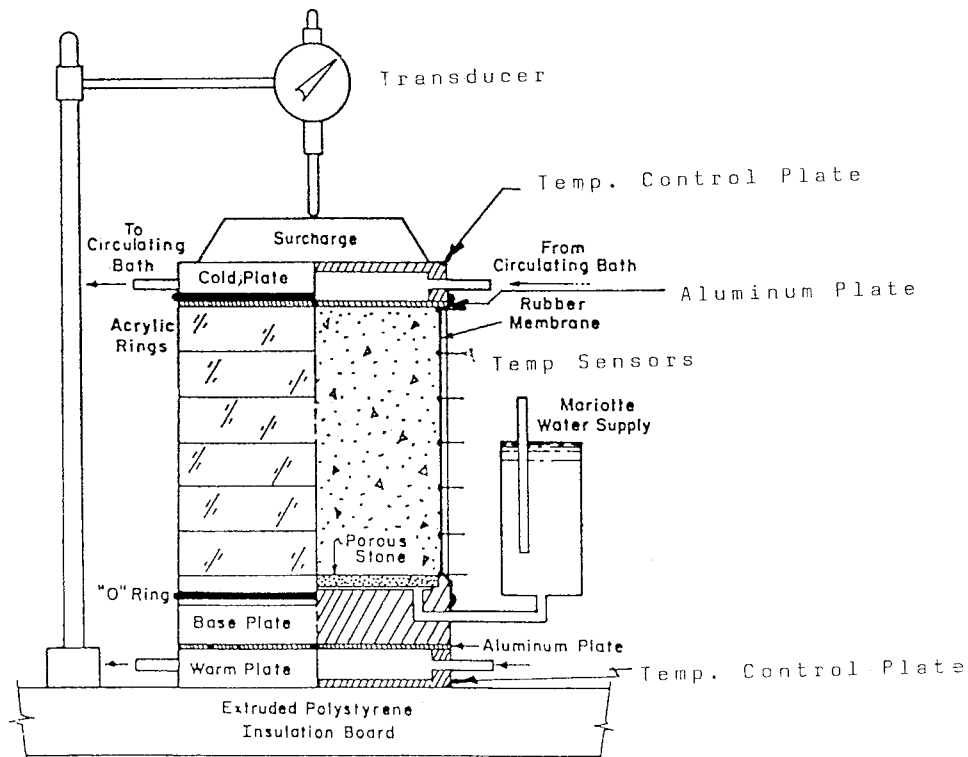

FIG. 2 Sample Assembly for Freezing Test

in.). The second recess is to have a diameter of 125.4 mm (4.94 in.) and a depth of 9.5 mm (0.375 in.) to facilitate access of the water supply to the underside of the porous stone (or disk). The base plate is to have two ports diametrically opposite, connecting to the deepest recess in the base (see Fig. 2). One port is to be connected to the external water supply reservoir; the second port is used to drain water and to flush air from beneath the porous stone (disk).

6.2.3 Rings—Same as 6.1.4.

6.2.4 *Constant Head (Mariotte) Water Supply*—The water supply reservoir is to consist of a clear acrylic plastic tube that has an inside diameter of at least 57 mm (2.25 in.) and a height of 508 mm (20.0 in.) (see Fig. 2). The top and bottom of the reservoir are sealed. The top is removable to allow filling with water. The bottom of the reservoir is connected to the inlet port on the sample base plate with a flexible plastic tube. A hose clamp is used to open or shut off the flow of water. A glass tube (called a bubble tube), with an inside diameter of about 3 mm (0.125 in.) and a length of 533 mm (21.0 in.), is placed through a vacuumtight fitting in the top of the tube. A second flexible tube is connected to the drain port on the sample base plate. When water flows out of the reservoir tube to the sample, air fills the bubble tube and the water head becomes fixed at the bottom of the bubble tube. When water flows out of the sample, the water head remains at the bottom of the bubble tube as long as the drain tube is open and is positioned at the same elevation as the bottom of the bubble tube. The water head elevation is adjusted by raising or lowering the reservoir tube and the drain tube. A transparent scale, attached to the side of the reservoir tube, allows tracking the water flow. The flow rate can also be followed electronically with a pressure transducer.

6.2.5 *Surcharge Weight*—The surcharge weight is a circular lead disk weighing 5.5 kg (10.0 lb) with an outside diameter of 142.0 mm (5.6 in.) that is placed on top of the test sample.

6.2.6 *Heave and Consolidation Measuring Apparatus*—A vertical post with a minimum diameter of 16 mm (0.625 in.) and a minimum height of 508 mm (20 in.) fixed to the base plate of the test sample, shall provide support for an adjustable arm to hold the displacement dial gage or displacement transducer, or both (see Fig. 2). The dial gages and displacement transducers shall be capable of measuring vertical movements of 25.4 mm (1.0 in.) with an accuracy of 0.025 mm (0.001 in.). The transducers must be calibrated frequently. This can easily be done for each test if a dial gage is coupled to the displacement transducer as shown in Fig. 2.

6.3 *Temperature Control Baths*—Two sources of temperature-controlled circulating liquid, such as an ethylene glycolwater 50 % solution, are required. One source is to be used to control the temperature of the top temperature control plate and the second source is to control the temperature of the bottom temperature control plate. Both sources shall have a controllable temperature range from  $-15^{\circ}\text{C}$  ( $5^{\circ}\text{F}$ ) to  $15^{\circ}\text{C}$  ( $59^{\circ}\text{F}$ ) and be capable of maintaining the temperature at each temperature control plate to within  $+0.2^{\circ}\text{C}$  ( $0.4^{\circ}\text{F}$ ) of the preset temperatures.

6.4 *Temperature Control Chamber*—The temperature control chamber in which the freeze-thaw tests are to be conducted shall have inside dimensions that will house the test sample

freezing assembly. Fig. 3 shows a  $0.35\text{-m}^3$  ( $12\text{-ft}^3$ ) capacity chest-type freezer adapted to accommodate four test samples. A refrigerator or cold room could also be used. The cold chamber shall have the capability of maintaining the ambient air temperature around the test sample assemblies at  $2^{\circ}\text{C}$  ( $35.6^{\circ}\text{F}$ ) within  $\pm 1.0^{\circ}\text{C}$  ( $2^{\circ}\text{F}$ ).

6.5 *Temperature Measuring System*—The temperature measuring system shall have a range from  $-15^{\circ}\text{C}$  ( $5.0^{\circ}\text{F}$ ) to  $15^{\circ}\text{C}$  ( $59.0^{\circ}\text{F}$ ) and shall be capable of measuring temperatures within  $\pm 0.1^{\circ}\text{C}$  ( $0.2^{\circ}\text{F}$ ). The temperature sensors shall be small enough [less than 3.2 mm (0.125 in.)] to permit their insertion into the soil test sample with a minimum of disturbance to the soil (see Fig. 4). The temperature readings are to be taken periodically and may be taken manually. It is preferable that the temperatures be read with an automated data logging system.

6.6 *Miscellaneous Apparatus*—Other general apparatus such as a mixing bowl, straightedge, scales, oven, filter paper, test tubes, loose insulation, and dishes are required.

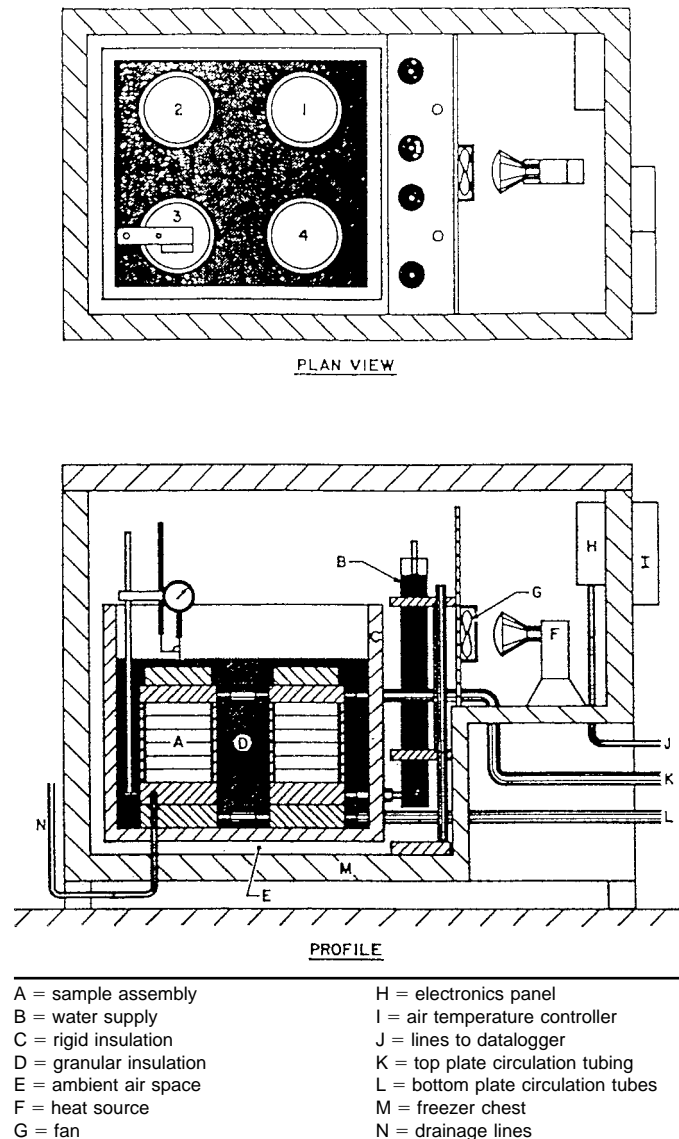

FIG. 3 Freeze Cabinet Assembly for Freezing Test

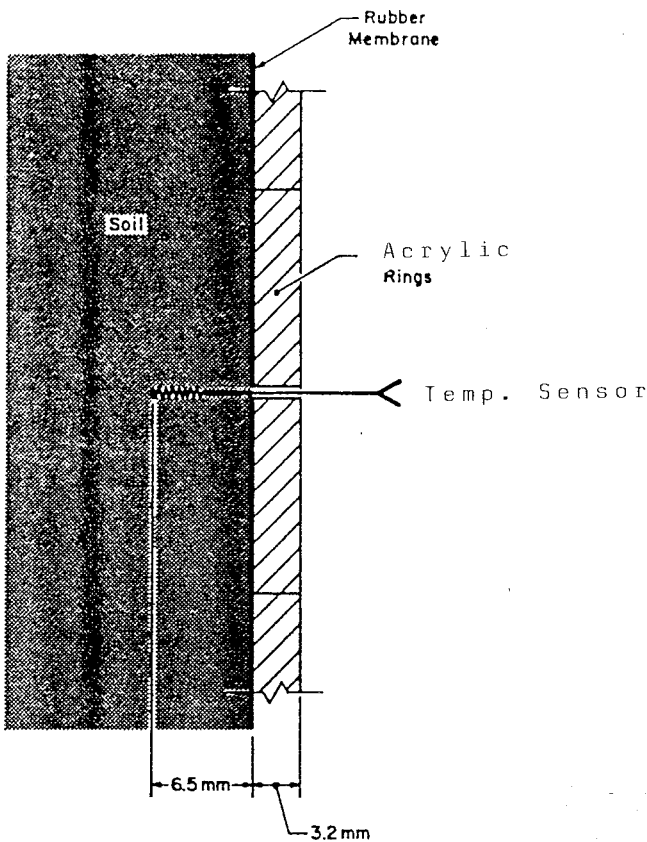

FIG. 4 Location of Temperature Sensors in the Test Sample

## 7. Soil Sampling and Preparation

7.1 Take soil samples undisturbed when possible. Undisturbed samples usually can only be prepared for fine-grained soils, in particular competent silt and clay soils found in the subgrade of roads. Where the soil is to be remolded and compacted in the field, use laboratory-compacted soils. In all cases, the sampling procedures should be in accordance with Practices D 420 and D 75. Recommendations for obtaining representative samples in Practices E 105 and E 122 should also be considered. Samples are obtained and prepared as follows:

7.1.1 *Undisturbed Samples*—Obtain undisturbed samples in accordance with Practice D 1587 using a thin-walled tube, in accordance with Practice D 3550 using a ring-lined barrel sampler, or by cutting samples from blocks of soil obtained by careful field sampling. Place the samples in sealed containers to minimize loss of moisture and mechanical damage during transport and storage. Determine the water content in accordance with Test Method D 2216 on about 500 g (1.1 lb) of trimmings or adjacent samples. Record the method of sampling and water content.

7.1.2 *Remolded Samples*—The dry density and moisture content required for the test should be determined from analysis of in situ conditions or from a compaction test such as Test Method D 698. The project requirements determine the moisture-density specifications. Select a representative sample in accordance with Test Method C 702 weighing approximately 6.0 kg (13.6 lb) and mix it well; then determine the water content following Test Method D 2216 on a 500-g

(1.1-lb) subsample. Adjust the moisture content of the remaining soil to the desired compaction value and allow the sample to condition for 24 h in a closed container. Prepare the sample to the desired dry unit weight in accordance with the procedure given under Section 8 using the mold assembly shown in Fig. 1. The method used shall be noted in the report. Record the method of sampling and water content.

## 8. Sample Preparation

8.1 *Undisturbed Samples*—Carefully trim the core or block specimen obtained from the field to 171.5 mm (6.75 in.) in diameter and 152.4 mm (6.0 in.) in height. A special jig, using a wire saw or a sharp straightedge and a trimming guide, will facilitate this process. Leave the final trimming of the ends until after the acrylic rings are in place. Weigh the rings (with filament tape for closure), membrane, and two acrylic disks together, and record the results. Set the sample on an acrylic base disk and place the rubber membrane over the prepared sample so that sufficient lengths of the membrane extend beyond the sample ends to allow seals with the end plates. Place the six acrylic rings around the sample, one at a time, starting at the bottom. Make sure that the holes in the rings align vertically. The top and bottom rings have grooves cut in them to facilitate placing temperature sensors on the end surfaces. These grooves must be placed facing the ends of the sample and aligned with the holes in the other rings. Hold the rings tightly in conformance with the rubber membrane and the sample, and tape the split in each ring tightly closed with filament tape. Trim the top and bottom of the sample level with the end acrylic rings. Continue with 8.3.

### 8.2 *Remolded Samples:*

8.2.1 *Mold Preparation*—Assemble the six acrylic rings, and tape the split in each ring tightly closed with filament tape. Stretch the rubber membrane, and make sure that it contains no holes or defects. Weigh the rings, membrane, and the acrylic disks together, and record the results. Assemble the mold by first placing one of the three steel side wall sections in the recess in the steel base plate. Next, place an acrylic spacer disk with a rubber membrane wrapped around it into the bottom of the mold. The rubber membrane should lie collapsed on top of the acrylic spacer disk. Then, place a second side wall section on the steel base, fitting it snugly against the first section. Next, place the acrylic rings into the mold, one at a time. The temperature sensor holes in the rings shall be aligned vertically. The grooves in the top and bottom rings must be positioned facing the ends of the sample and aligned with the holes in the other rings. The mold assembly should now look as shown in Fig. 1. After the six acrylic rings are in place, position the third steel side wall section to complete the side wall assembly. Then, position four hose clamps around the outside of the side wall assembly, evenly spaced vertically, and tighten them. Then position the collar and lock in place to the steel rods with the wing nuts. Pull up the rubber membrane and stretch it over the top edge of the assembly. Make sure that the membrane is tight and free of ripples. The sample can now be compacted in the mold.

8.2.2 *Compaction*—Place and compact the soil in the mold in five layers of equal thickness. The amount of compaction effort will be determined by the dry unit weight that is desired.

Usually this will be determined from site conditions for undisturbed subgrade soils or from compaction specifications for base and subbase materials. A standard Proctor rammer (see Test Method D 698) is preferred for compaction because the tube guide protects the rubber membrane from damage during compaction. During compaction, make a water content determination on a 500-g (1.1-lb) subsample. Enter the information on the data sheet. Compact the sample level with the top of the uppermost acrylic ring. Place a second acrylic spacer disk on the top. Fold up the rubber membrane and remove the compacted sample assembly from the steel mold. Leave the acrylic spacer disks in place to prevent damage to the sample and to provide moisture seals.

**8.3 Sample Property Determination**—Weigh the assembled sample, including the acrylic rings with the filament tape, the rubber membrane, and the acrylic spacer disks. Record the results and calculate the wet and dry unit weights, void ratio, porosity, and degree of saturation.

**8.4 Freezing Point Depression Determination**—See Appendix X1.

**8.5 Mounting the Sample for Testing**—Place a piece of filter paper on the porous stone (or porous stainless steel disk) in the base assembly. Roll the rubber membrane over the outside of the acrylic ring at the bottom end of the sample assembly, and remove the acrylic disk. Position the sample on the base so that the holes for the temperature sensors are located on the surface farthest away from the post that carries the dial gage and the displacement transducers. Roll down the rubber membrane over the base, and seal it with heavy rubber bands or O-rings (see Fig. 2).

#### 8.6 Saturating the Sample:

**8.6.1** Follow the saturation procedure for all subgrade materials and for base and subbase materials where there is a chance of saturation under field conditions. For regions where there is little precipitation and water tables are deep or for pavement designs where lateral drainage in the upper pavement section is very good, conduct the test at the field moisture content without the saturation procedure. Closed-system freezing should be used for this condition. In special cases, open-system freezing can be used with lower water table settings to simulate field conditions. Proceed to 8.7 if the sample will not be saturated prior to freezing.

**8.6.2** Connect the inlet and outlet water lines to the sample base. Roll-down the rubber membrane at the top. Place a piece of thin plastic wrap over the top of the sample to prevent moisture evaporation. Center the surcharge weight on top of the acrylic disk.

**8.6.3** Clamp off the inlet and outlet lines to the base plate of the sample. Fill the water supply reservoir with distilled water, and install the top cap with the long glass bubble tube attached. Lower the bubble tube down to an elevation 25 mm (1.0 in.) above the bottom of the soil sample. Purge the air from the sample base plate by opening both the water supply and the drain lines. Collect the water flowing from the drain line until the air is completely purged from the system. Close the clamp on the drain line. The sample is now ready to be saturated. Raise the water head at the rate of 25 mm/h until excess water appears on the upper surface of the sample or until 8 h have

passed. Then lower the water supply head to the elevation of the top of the soil sample and hold it there for 16 h. After the 24-h saturation period is completed, lower the bubble tube to a point 10 mm (0.5 in.) above the bottom of the sample.

**8.6.4** For tests that justify simulating the water table depth in the field, the constant head water supply should be appropriately positioned. If the head is placed below the bottom of the sample, then a porous stone having a 1-bar [100-kPa (14.7-psi)] air entry value must be placed in the base, instead of the normal porous stone or plate, to stop air from passing through the stone into the water supply system. This stone must be saturated with de-aired water. Because of cavitation in the water system, the practical limit for simulating the depth to the water table when using this procedure is about 7.6 m (25 ft). In ordinary laboratory space, the practical limit is further restricted to about 1.2 m (4 ft) below the sample base without a provision for placing the water supply reservoirs at lower story levels. A system controlled by a vacuum regulator could be used to simulate lower water table elevations also, but experience has shown that this type of system is very difficult to keep stable.

**8.7 Placing the Sample in the Temperature Control Chamber**—Clamp off the water supply line, and carefully move the sample and water supply to the cold chamber (cold room). Position the sample assembly atop the bottom temperature control plate located inside the temperature control cabinet (see example in Fig. 3) so that the temperature sensor holes are pointing in a direction that is convenient for attaching the sensors to the sample.

**8.8 Installing Temperature Sensors**—Install the eight temperature sensors into the side of the sample, starting at the bottom of the sample. Number the sensors from the top down. Dip each sensor into liquid silicone rubber, and then push it through the hole in the acrylic ring, through the rubber membrane, and into the sample for a distance of about 6.5 mm (0.25 in.) as shown in Fig. 4. Puncturing the membrane with the end of a paper clip will facilitate this procedure. A small drill bit and portable drill can be used to prepare a hole in stiff or hard materials. Use the sharpened end of a small-diameter steel tube to puncture the rubber membrane if the latter procedure is used. This will prevent twisting of the membrane by the drill bit. After placing all the sensors, dab a little silicone rubber on the places where the sensors penetrate the acrylic rings to form a water seal. Connect the sensors to the appropriate terminals on the data logging system junction box. Check each temperature sensor for an appropriate reading.

**8.9 Completing the Test Assembly**—Remove the surcharge weight and the plastic disk from the top of the sample. Place the temperature control plate assembly on top of the sample, and fold the rubber membrane up to overlap the top temperature control plate. Then seal the top of the membrane to the plate with rubber bands (see Fig. 2). Connect the circulating liquid lines to the top plate assembly. Place the surcharge weight on top of the plate and center it. Place the dial gage and the displacement transducer assemblies on the vertical support post. Center the dial gage and displacement transducer on the top of the sample assembly. Lower the gage so that it reads near 0.00 and record the reading. Connect the displacement

transducers to the appropriate terminals and check their operation. Fill the insulated box containing the test assembly with loose insulation (see Fig. 3) after the entire assembly has passed the check-out procedures.

**9. Procedure**

9.1 *Boundary Temperatures*—The top and bottom cooling plates are set at fixed temperatures (see Table 1) for specified time periods to induce a conditioning period and two freeze-thaw cycles. If the freezing point depression temperature is lower than  $-0.25^{\circ}\text{C}$  ( $31.5^{\circ}\text{F}$ ), then the specified temperatures in Table 1 should be lowered by the amount of the freezing point depression.

9.1.1 *Conditioning the Sample*—The first 24 h is a conditioning period. Both the top and bottom plates are held at  $3^{\circ}\text{C}$  ( $37.4^{\circ}\text{F}$ ).

9.1.2 *First Freezing Period*—The first freeze starts at the beginning of the second 24-h period. First record the initial dial gage or transducer readings; record each if both are being used. Lower the temperature of the top plate, and hold it at  $-3^{\circ}\text{C}$  ( $26.6^{\circ}\text{F}$ ) and the bottom plate at  $3^{\circ}\text{C}$  ( $37.4^{\circ}\text{F}$ ) for 8 h. After 8 h, lower the temperatures of the top plate to  $-12^{\circ}\text{C}$  ( $10.4^{\circ}\text{F}$ ) and the bottom plate to  $0^{\circ}\text{C}$  ( $32.0^{\circ}\text{F}$ ). Hold these temperatures for 16 h. Table 1 shows the details of the cooling plate temperature settings.

9.1.3 *Nucleation*—If the top temperature sensor reading is  $1^{\circ}\text{C}$  ( $1.8^{\circ}\text{F}$ ) lower than the freezing temperature of the soil pore water (see appendix), initiate ice nucleation by delivering two sharp blows with a metal rod to the top of the cold plate. The readings from the top temperature sensor will rise if nucleation occurred. Other evidence of nucleation may be a positive frost heave rate. Repeat this process for each additional  $0.5^{\circ}\text{C}$  ( $0.9^{\circ}\text{F}$ ) drop below the freezing point of the soil pore water until ice nucleation is achieved. Spontaneous nucleation will occur without applying the sharp blows; however, the nucleation temperature may be very low and instantaneous freezing of the top several centimetres of the samples may occur. This should be avoided; only unidirectional progressive freezing is desired.

9.1.4 *First Thawing Period*—The first thaw starts at the beginning of the third 24-h period. Raise the top plate temperature and hold it at  $12^{\circ}\text{C}$  ( $53.6^{\circ}\text{F}$ ) and raise the bottom plate temperature and hold it at  $3^{\circ}\text{C}$  ( $37.4^{\circ}\text{F}$ ) for 16 h. During the next 8 h, hold both the top and bottom plate temperatures at  $3^{\circ}\text{C}$  ( $37.4^{\circ}\text{F}$ ). See Table 1 and Fig. 5 for the temperature settings and timing.

9.2 *Purging Air from Base*—To remove air from the sample

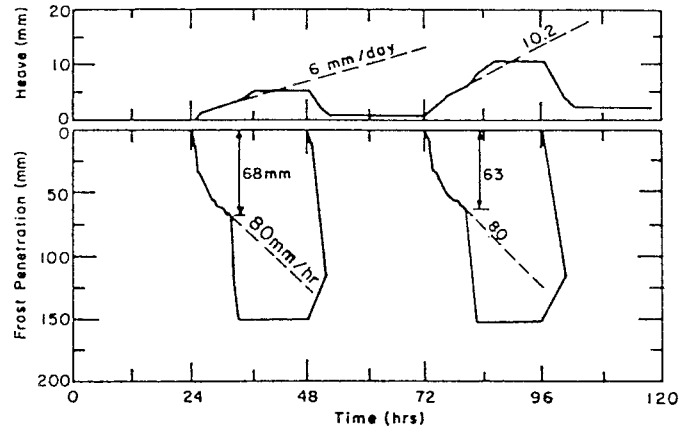

**FIG. 5 Example of the Freeze-Thaw Test Results and Selection of the Frost Heave Rate**

base after thawing, open the drainage line in the base, and allow water to flow until bubbles cease to appear. Maintain the outlet of the drainage line a few millimetres above the water head elevation to prevent water from draining out. If a large amount of air is present, a slight suction applied to the drain hose should start the flow. Refill the water supply reservoir, if necessary, after purging the sample base of air.

9.3 *Second Freezing Period*—The second freeze starts at the beginning of the fourth 24-h period. This procedure is the same as that used in the first freeze.

9.4 *Second Thawing Period*—The second thaw starts at the beginning of the fifth 24-h period. This procedure is the same as that used for the first thaw.

9.5 *Measurements During Freeze-Thaw Test*—Read all temperature sensors and displacement transducers at least every half hour throughout the first 8-h of freezing and at 1-h intervals thereafter.

9.6 *Completing the Freeze-Thaw Test*—At the end of the second thaw period (120 h after the start of the test), record the dial gage reading. Turn off the circulating liquid to the temperature control plates. Remove the dial gage and the displacement transducer assemblies. Remove the surcharge weights and the top temperature control plate assembly. Remove enough of the loose insulation to allow access to the temperature sensors and the water lines. Remove the temperature sensors from the side of the sample by pulling them gently away from the acrylic rings. Now, remove the sample assembly, complete with base plate, from the temperature control chamber.

**10. Conducting the Bearing Ratio Test After Thawing**

10.1 Move the sample from the base and carefully place it on an aluminum pie plate of known tare weight. Weigh the sample and the pie plate. Slide a 150-mm (6-in.) diameter hose clamp over each acrylic ring and tighten. Remove the plastic film from the top of the sample. Conduct a bearing ratio test on the sample, in accordance with Test Method D 1883, but limit the penetration to 7.6 mm (0.3 in.) of depth. Take a small water content sample from the area where the bearing ratio piston penetrated the sample. Determine the wet and dry weights and water content. Remove the hose clamps, acrylic rings, and rubber membrane from the sample, and cut the sample into six

**TABLE 1 Boundary Temperature Conditions**

Day	Elapsed Time, h	Top Plate Temperature, °C	Bottom Plate Temperature, °C	Comments
1	0	3	3	24-h conditioning
2	24	-3	3	First 8-h freeze freeze to bottom
	32	-12	0	
3	48	12	3	First thaw
	64	3	3	
4	72	-3	3	Second 8-h freeze freeze to bottom
	80	-12	0	
5	96	12	3	Second thaw
	112 to 120	3	3	

horizontal slices of approximately equal thickness. Determine the water content of each slice.

10.2 The bearing ratio should also be determined for a sample that has not been frozen. This sample should be prepared at the same moisture and density conditions as the freeze-thaw test sample. The test should be conducted in accordance with Test Method D 1883

**11. Determining the Frost-Susceptibility**

11.1 Use the two heave rates and the bearing ratio values to determine the frost-susceptibility using the criteria given in Table 2.

11.1.1 Compare the 8-h frost heave rates observed during the first and second freeze-thaw cycles with each other. If there

FREEZE-THAW SAMPLE PREPARATION  
SAMPLE DATA SHEET

Project Stark Material Pompi River Date 2/23/90  
Sample No. RK#1 Specific Gravity 2.73 Technician CES

In-Situ Properties

Dry density 2.083 g/cc  
Water content 4.0 %

Method of Sampling

SHOVEL IN PIT

Compaction Mode

No. layers 5  
Layer height 32 mm  
Blows per layer 56  
Type of rammer modified  
Weight of rammer 4.54-Kg

Method of Sample Preparation

Undisturbed X  
Compacted X

Specified Properties

Dry density 2.210 g/cc  
Water content 5.8 %

Sample Data

Wt. mold, rings, membrane & disk 317.2 g Volume of mold  $V_t$  2531.2 cc  
Wt. mold + wet soil ( $W_{m,s,w}$ ) 6225.0 g  
Wt. wet soil ( $W_{s,w}$ ) 5907.8 g  
Wet unit weight ( $\gamma_t = W_{s,w}/V_t$ ) 2.334 g/cc

Water Content of Compacted Soil

tare no. 4 wt. water ( $W_w$ ) 521.7 g  
wt. tare ( $W_t$ ) 16.50 g wt. dry soil ( $W_s$ ) 866.93 g  
wt. tare + wet soil ( $W_{t,s,w}$ ) 935.60 g water content:  
wt. tare + dry soil ( $W_{t,s}$ ) 883.43 g  $w = 100 \times W_w / W_s$  6.0 %

Dry unit weight ( $\gamma_d = \gamma_t / (1 + w/100)$ ) 2.204 g/cc

Sample Properties (for  $V_t = 1.0$  cc)

Vol. solids ( $V_s = \gamma_d V_t / G_s \gamma_w$ ) 0.807 cc Saturation ( $S = w G_s / e$ ) 68.5 %  
Vol. voids ( $V_v = 1 - V_s$ ) 0.193 cc Porosity ( $n = 100 \times V_v / V_t$ ) 19.3 %  
Void Ratio ( $e = V_v / V_s$ ) 0.239

FIG. 6 Example of Sample Preparation Data Sheet



**TABLE 2 Tentative Frost-Susceptibility Criteria<sup>A</sup>**

Frost-Susceptibility Classification	Symbol	8-h Heave Rate, mm/day	Bearing Ratio After Thaw, %
Negligible	NFS	<1	>20
Very low	VL	1 to 2	20 to 15
Low	L	2 to 4	15 to 10
Medium	M	4 to 8	10 to 5
High	H	8 to 16	5 to 2
Very high	VH	>16	<2

<sup>A</sup> The criteria will be updated with experience. The bearing ratio criteria should be used only as a guide; if the CBR test is used for design, it should be noted that the thaw CBR value occurs only for a few weeks per year.

is a significant increase (or decrease) during the second freeze, as there is in the example shown in Fig. 7, then the heave rate selected will depend on the site conditions. If the site is in a very temperate region where many freeze-thaw cycles occur and the water table is near the zone of freezing and thawing, then the 8-h heave rate during the second freeze should be selected. If the site is in a more severe winter climate where the frost penetration is more continuous during the winter and does not reach the water table, then the 8-h heave rate during the first freeze should be selected.

11.1.2 The heave rate criteria allow the determination of the frost heave susceptibility of a material that can be related to pavement roughness during the freezing period. The thaw bearing ratio value allows the determination of the thaw weakening susceptibility of the material. Compare the thaw bearing ratio value with the bearing value for no freezing or the design bearing value to determine the frost-susceptibility. Tentative criteria in Table 2 can be used to determine the thaw weakening susceptibility if no bearing ratio specifications are available. The thaw weakening susceptibility criteria are based upon comparisons of bearing ratios (after two freeze-thaw cycles in the laboratory) with pavement deflection measurements (made during spring thaw with simulated wheel loadings). The thaw weakening period is normally two to four weeks in seasonal frost regions. Thus, the thaw bearing ratio value covers only this period of time.

## 12. Report

12.1 Report the following information (see Fig. 6 and Fig. 7 for examples):

12.1.1 Identification and description of the test sample, including whether the soil is undisturbed or compacted.

12.1.2 Type of sample: undisturbed or compacted.

12.1.3 Sampling procedure, including type of sampler or method.

12.1.4 Compaction mode, including the number of layers, layer thickness, number of blows per layer, and type and weight of rammer.

12.1.5 Weights and volumes measured and the moisture content and density determined.

12.1.6 Specific gravity of solids.

12.1.7 Degree of saturation, void ratio, and porosity before freezing.

12.1.8 Condition of test (natural moisture or soaked).

12.1.9 Open or closed system.

12.1.10 Elevation of water table.

12.1.11 Freezing point depression temperature.

12.1.12 Bearing ratio before freeze-thaw cycling (from standard test).

12.1.13 Plot of the frost heave versus time for both freeze-thaw cycles.

12.1.14 Plot of the frost depth versus time for both freeze-thaw cycles.

12.1.15 Bearing ratio after freeze-thaw cycling.

12.1.16 Water content for each of six layers after freeze-thaw cycling.

12.1.17 Plot of water content profile after freeze-thaw cycling.

12.1.18 Frost heave susceptibilities for each freeze-thaw cycle.

12.1.19 Thaw weakening susceptibility.

## 13. Precision and Bias

13.1 *Type II Precision Statement:*

13.1.1 *Statement of Precision*—Due to the nature of the soil or rock materials tested by this test method, it is either not feasible or too costly at this time to produce multiple specimens that have uniform physical properties. Any variation observed in the data is just as likely to be due to specimen variation as to operator or laboratory testing variation. Subcommittee D18.19 welcomes proposals that would allow for development of a valid precision statement.

13.2 *Bias Statements*—Since it is impossible to develop a “true” value for most soil and rock test methods, the use of the following bias statements is considered acceptable:

13.2.1 *Statement of Bias*—There is no accepted reference value for this test method, therefore, bias cannot be determined.

## 14. Keywords

14.1 freeze-thaw test; frost susceptibility; roads and runways; soil and aggregate; thaw weakening susceptibility

FREEZE-THAW TEST RESULTS

Project Stark  
 Sample No. RK#1

Date 2/23/90  
 Technician UE

Initial Sample Properties

Water Content 6.0 %  
 Dry Density 2.204 g/cc  
 Porosity 19.3 %  
 Void Ratio 0.239  
 Saturation 68.5 %

Freeze-Thaw Test Conditions

Soaked ?  Unsoaked ?   
 Open  Closed  System ?  
 Water Table Elevation 1.0 cm  
 Freezing Point Depression -0.1 °C

Properties after Freeze-Thaw

Slice No.	Thickness mm	Tare No.	W <sub>t</sub> g	W <sub>t,s,w</sub> g	W <sub>t,s</sub> g	W <sub>w</sub> g	W <sub>s</sub> g	w %
1	25.4	1	16.16	1022.19	945.00	77.19	928.84	8.31
2		2	16.07	1019.64	941.48	78.16	925.41	8.45
3		3	16.08	1032.78	959.69	78.09	938.61	8.32
4		4	16.12	1033.22	952.68	80.54	936.56	8.60
5		5	16.17	1018.17	938.31	79.86	922.14	8.60
6		6	16.04	1022.65	941.21	81.44	932.87	8.73

Frost Heave and Frost Penetration

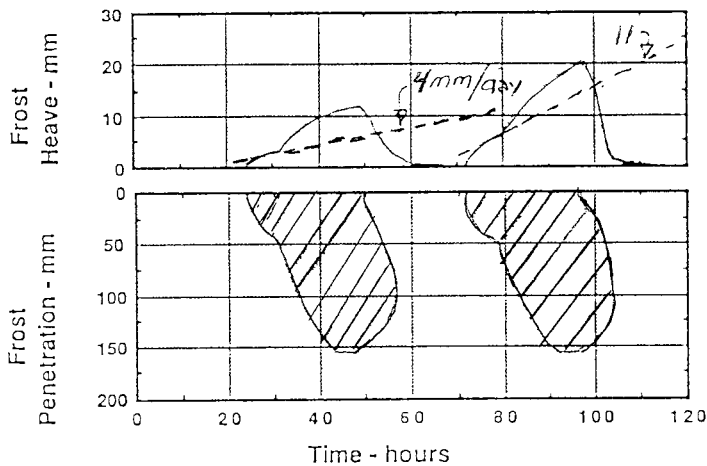

Water Content Profile

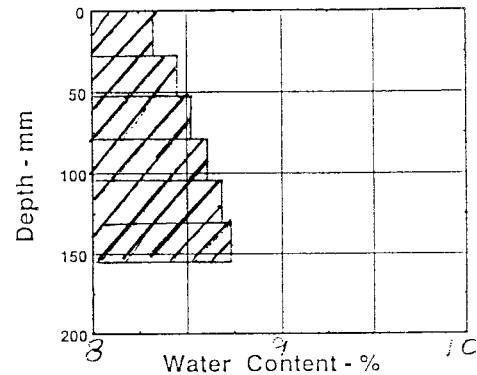

Frost Susceptibility Classification System

Frost Susceptibility	Heave Rate mm/day	Thaw CBR %
neg.	<1	>20
very low	1-2	20-15
low	2-4	15-10
medium	4-8	10-5
high	8-16	5-2
very high	>16	<2

Test Results

CBR before freeze-thaw 40.2 %  
 CBR after freeze-thaw 4.9 %  
 Heave rate 1st freeze 4.0 mm/day  
 Heave rate 2nd freeze 11.0 mm/day

Frost Heave Susceptibility  
 after 1st freeze low  
 after 2nd freeze high

Thaw weakening susceptibility  
 after 2 f/t cycles high

FIG. 7 Example of Test Results Summary Data Sheet

APPENDIX

(Nonmandatory Information)

X1. RECOMMENDED METHOD TO OBTAIN THE FREEZING-POINT DEPRESSION

X1.1 The freezing temperature of the pore water in soils is commonly below 0°C (32°F). The depression of the freezing point of the water in soil is due to the effects of particle size, mineralogy, and chemistry. Generally, the temperature at which water in soil begins to freeze decreases with increasing amounts of fine-grained particles. The addition of salts also decreases the freezing point of soil water.

X1.2 The freezing point can be determined by placing a temperature sensor into a small amount of the test soil in a test tube and observing temperature changes during freezing. The accuracy of the temperature measurement system should be to within ±0.05°C (±0.09°F). The soil should be placed in the test tube at approximately the same density and moisture content as in the freezing test. Fig. X1.1 illustrates the arrangement. A refrigerated cold bath capable of maintaining the temperature at -3.00°C (-26.6°F) is used to induce freezing. The temperature data are continuously recorded.

X1.3 The freezing-point depression is determined as follows:

X1.3.1 Compact the soil in a clean test tube to a depth of 20 mm.

X1.3.2 Insert the temperature sensor 10 mm into the center of the soil as shown in Fig. X1.1. (This can be done by making a pilot hole with a needle slightly smaller than the temperature sensor or by compacting the soil around the sensor.)

X1.3.3 Connect the sensor to the recorder.

X1.3.4 Place the test tube in a slurry of ice and water and allow the temperature to equilibrate at 0°C (32°F).

X1.3.5 Immerse the test tube in a ethylene glycol-water solution in a refrigerated cold bath. The temperature should be at -3°C (26.6°F).

X1.3.6 Observe and record the temperature with time.

X1.3.7 Select the freezing-point depression temperature as shown in Fig. X1.2. The initial part of the temperature record is characterized by super-cooling of the pore water and warming after spontaneous nucleation. The temperature then remains constant for a period of time while the water in the region of the sensor freezes. This is the freezing-point depression temperature. Then, as the ice that has formed begins to cool, the temperature again falls.

X1.3.8 Thaw the sample; remove the temperature sensor; determine the water content. Make sure that the water content is equal to or greater than the required value.

X1.3.9 Record the freezing-point depression temperature and the water content.

X1.4 The freezing-point depression temperature is used for three purposes. The first is to determine the boundary temperatures during freezing and thawing. If the freezing point depression temperature is lower than -0.25°C (31.5°F), then the boundary temperatures should be lowered by an amount equal to the freezing-point depression temperature. The second purpose for measuring the freezing point of the pore water is to determine the temperature at which nucleation will be initiated in the freezing test. Finally, the freezing point of the pore water is also used to determine the depth of freezing and thawing.

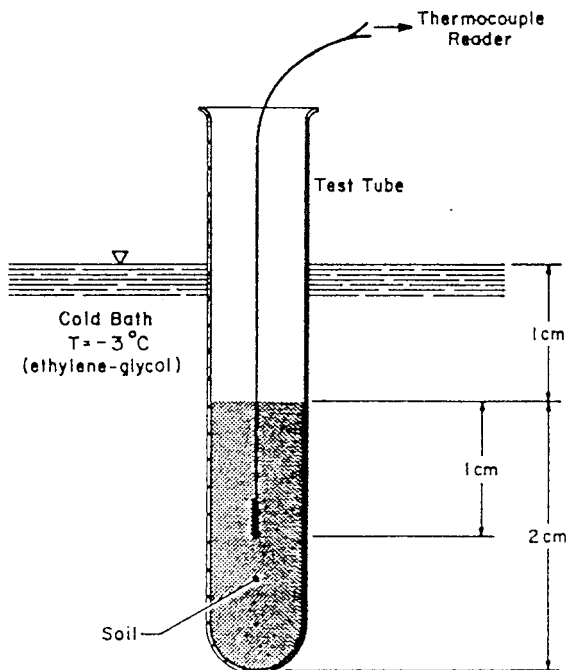

FIG. X1.1 Setup for Determining the Freezing-Point Depression

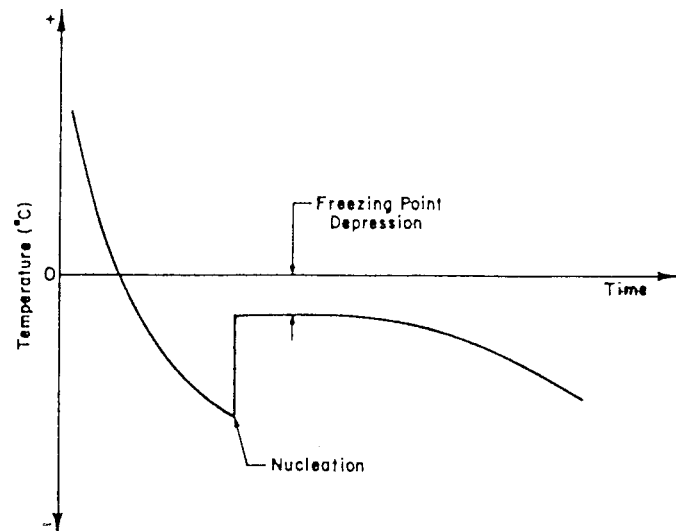

FIG. X1.2 Selecting the Freezing-Point Depression from the Cooling Curve

 **D 5918**

*The American Society for Testing and Materials takes no position respecting the validity of any patent rights asserted in connection with any item mentioned in this standard. Users of this standard are expressly advised that determination of the validity of any such patent rights, and the risk of infringement of such rights, are entirely their own responsibility.*

*This standard is subject to revision at any time by the responsible technical committee and must be reviewed every five years and if not revised, either reapproved or withdrawn. Your comments are invited either for revision of this standard or for additional standards and should be addressed to ASTM Headquarters. Your comments will receive careful consideration at a meeting of the responsible technical committee, which you may attend. If you feel that your comments have not received a fair hearing you should make your views known to the ASTM Committee on Standards, 100 Barr Harbor Drive, West Conshohocken, PA 19428.*