

This document is not an ASTM standard and is intended only to provide the user of an ASTM standard an indication of what changes have been made to the previous version. Because it may not be technically possible to adequately depict all changes accurately, ASTM recommends that users consult prior editions as appropriate. In all cases only the current version of the standard as published by ASTM is to be considered the official document.



Designation: **D 6128 – 9700**

Standard Shear Testing Test Method for Shear Testing of Bulk Solids Using the Jenike Shear Cell¹

This standard is issued under the fixed designation D 6128; the number immediately following the designation indicates the year of original adoption or, in the case of revision, the year of last revision. A number in parentheses indicates the year of last reapproval. A superscript epsilon (ϵ) indicates an editorial change since the last revision or reapproval.

¹ This testing method is under the jurisdiction of ASTM Committee D-18 on Soil and Rock and is the direct responsibility of Subcommittee D18.24 on Characterization and Handling of Powders and Bulk Solids.

Current edition approved ~~May 10, 1997~~ November 10, 2000. Published ~~October 1998~~ March 2001. Originally published as D 6128 – 97. Last previous edition D 6128 – 97.

1. Scope*

1.1 This method² covers the apparatus and procedures for measuring the cohesive strength of bulk solids during both continuous flow and after storage at rest. In addition, measurements of internal friction, bulk density, and wall friction on various wall surfaces are included.

1.2 This standard is not applicable to testing bulk solids that do not reach the steady state requirement within the travel limit of the shear cell. It is impossible to classify ahead of time which bulk solids cannot be tested, but one example may be those consisting of highly elastic particles.

1.3 The values stated in SI units are to be regarded as standard.

1.4 The most common use of this information is in the design of storage bins and hoppers to prevent flow stoppages due to arching and ratholing, including the slope and smoothness of hopper walls to provide mass flow. Parameters for structural design of such equipment may also be derived from this data.

1.35 This standard does not purport to address all of the safety concerns, if any, associated with its use. It is the responsibility of the user of this standard to establish appropriate safety and health practices and determine the applicability of regulatory limitations prior to use.

2. Referenced Documents

2.1 *ASTM Standards:*

D 653 Terminology Relating to Soil, Rock and Contained Fluids³

3. Terminology

23.1 *Definitions:*—Definitions of terms used in this test method are in accordance with Terminology D 653.

23.1.1 *adhesion test, n*—a static wall friction test with time consolidation.

3.1.2 *angle of internal friction, ϕ_i, n* —the angle between the axis of normal stress (abscissa) and the tangent to the yield locus and the abscissa.

2.1.2—locus.

3.1.3 *angle of wall friction, ϕ', n* —the arctan of the ratio of the wall shear stress to the wall normal stress.

2.1.3—

3.1.4 *bin, n*—a container or vessel for holding a bulk solid, frequently consisting of a vertical cylinder with a converging hopper. Sometimes referred to as silo, bunker, or elevator.

2.1.4—

3.1.5 *bulk density, ρ_b, n* —the mass of a quantity of a bulk solid divided by its total volume

2.1.5—

3.1.6 *bulk solid, n*—an assembly of solid particles handled in sufficient quantities that its characteristics can be described by the properties of the mass of particles rather than the characteristics of each individual particle. May also be referred to as granular material, particulate solid, or powder. Examples are sugar, flour, ore, and coal.

2.1.6—

3.1.7 *bunker, n*—synonym for bin, but sometimes understood as being a bin without any or only a small vertical part at the top of the hopper.

2.1.7—

3.1.8 *cohesive strength, n*—synonym for unconfined yield strength.

3.1.9 *consolidation, n*—the process of increasing the strength of a bulk solid.

2.1.8—

3.1.10 *critical state, n*—a state of stress in which the bulk density of a bulk solid and the shear stress in the shear zone remain constant.

3.1.11 *effective angle of friction, δ, n* —the inclination of the effective yield locus (EYL) as defined by Jenike.

2.1.9—

3.1.12 *effective yield locus (EYL), n*—straight line passing through the origin of the σ, τ -plane and tangential to the steady state Mohr circle, corresponding to steady state flow conditions of a bulk solid of given bulk density.

23.1.103 *elevator, n*—synonym for bin, commonly used in the grain industry.

23.1.114 *failure (of a bulk solid), n*—plastic deformation of an overconsolidated bulk solid subject to shear, causing dilation and a decrease in strength.

² This test method is based on the “Standard Shear Testing Technique for Particulate Solids Using the Jenike Shear Cell,” a report of the EFCE Working Party on the Mechanics of Particulate Solids. Copyright is held by The Institution of Chemical Engineers and the European Federation of Chemical Engineering.

³ This method

³ Annual Book of constructing the steady state Mohr circle is specified by Jenike, A. W., *Storage and Flow of Solids, Bulletin 123 ASTM Standards, Utah Engineering Experiment Station, 1964 (Rev. 1980) and by the Standard Shear Testing Technique for Particulate Solids using the Jenike Shear Cell, a report of the EFCE Working Party on the Mechanics of Particulate Solids. Copyright for the latter is held by The Institution of Chemical Engineers and the European Federation of Chemical Engineering, Rugby, England, 1989. Alternative methods of construction have been proposed. See, for example, Peschl, I.A.S.Z., “Measurement and Evaluation of Mechanical Properties of Powders,” *Powder Handling and Processing, Vol-1, No. 2, June 1989, pp. 135–142. 04.08.**

23.1.125 flow, steady state, n —continuous plastic deformation of a bulk solid at critical state.

23.1.136 flow function, FF, n —the plot of unconfined yield strength versus major consolidation stress for one specific bulk solid.

23.1.147 granular material, n —synonym for bulk solid.

23.1.158 hopper, n —the converging portion of a bin.

23.1.169 major consolidation stress, $\sigma_{1, n}$ —the major principal stress given by the Mohr stress circle of steady state flow. This Mohr stress circle is tangential to the effective yield locus.

~~2.1.17—~~

3.1.20 Mohr stress circle, n —the graphical representation of a state of stress in coordinates of normal and shear stress, that is, in the σ, τ -plane.

23.1.218 normal stress, σ, n —the stress acting normally to the considered plane.

23.1.22 overconsolidated specimen, n —a condition in which the shear force passes through a maximum and then decreases during preshear.

3.19.23 particulate solid, n —synonym for bulk solid.

23.1.204 powder, n —synonym for bulk solid, particularly when the particles of the bulk solid are fine.

23.1.215 silo, n —synonym for bin.

23.1.226 shear stress, τ —a stress acting parallel to the surface of the plane being considered.

2.1.23 shear test, n —an experiment to determine the flow properties of a bulk solid by applying different states of stress and strain to it.

23.1.247 shear tester, n —an apparatus for performing shear tests.

23.1.258 time angle of internal friction, ϕ, n —inclination of the time yield locus of the tangency point with the Mohr stress circle passing through the origin.

23.1.269 time yield locus, n —the yield locus of a bulk solid which has remained at rest under a given normal stress for a certain time.

~~2.1.27—~~

3.1.30 unconfined yield strength, f_c, n —the major principal stress of the Mohr stress circle being tangential to the yield locus with the minor principal stress being zero. A synonym for compressive strength.

23.1.31 underconsolidated specimen, n —a condition in which the shear force increases continually during preshear.

3.1.328 wall normal stress, σ_w, n —the normal stress present at a confining wall.

~~2.1.29—~~

3.1.33 wall shear stress, τ_w, n —the shear stress present at a confining wall.

23.1.304 wall yield locus, n —a plot of the wall shear stress versus wall normal stress. The angle of wall friction is obtained from the wall yield locus as the arctan of the ratio of the wall shear stress to wall normal stress.

23.1.315 yield locus, n —plot of shear stress versus normal stress at failure. The yield locus (YL) is sometimes called the instantaneous yield locus to differentiate it from the time yield locus.

4. Summary of Test Method

4.1 A representative sample of bulk solid is placed in a shear cell of specific dimensions. This specimen is preconsolidated by twisting the shear cell cover while applying a compressive load normal to the cover.

4.2 When running an instantaneous or time shear test, a normal load is applied to the cover, and the specimen is presheared until a steady state shear value has been reached.

4.3 An instantaneous test is run by shearing the specimen under a reduced normal load until the shear force goes through a maximum value and then begins to decrease.

4.4 A time shear test is run similarly to an instantaneous shear test, except that the specimen is placed in a consolidation bench between preshear and shear.

4.5 A wall friction test is run by sliding the specimen over a coupon of wall material and measuring the frictional resistance as a function of normal, compressive load.

4.6 A wall friction time test involves sliding the specimen over the coupon of wall material, leaving the load on the specimen for a predetermined period of time, then sliding it again to see if the shearing force has increased.

5. Significance and Use

35.1 Reliable, controlled flow of bulk solids from bins and hoppers is essential in almost every industrial facility. Unfortunately, flow stoppages due to arching and ratholing are common. Additional problems include uncontrolled flow (flooding) of powders, segregation of particle mixtures, useable capacity which is significantly less than design capacity, caking and spoilage of bulk solids in stagnant zones, and structural failures.

35.2 By measuring the flow properties of bulk solids, and designing bins and hoppers based on these flow properties, most flow problems can be prevented or eliminated.

35.3 For bulk solids with a significant percentage of particles (typically, one third or more) finer than about 6 mm (¼ in.), the

cohesive strength is governed by the fines (-6-mm fraction). For such bulk solids, cohesive strength and wall friction tests may be performed on the fine fraction only.

46. Apparatus

46.1 The Jenike shear cell is shown in Figs. 1-4 Fig. 13. It consists of a base (1), shear ring (2), and shear lid (3), the latter having a bracket (4) and pin (5). Before shear, the ring is placed in an offset position as shown in Fig. 1, and a vertical force F_v is applied to the lid, and hence, to the particulate solid within the cell by means of a weight hanger (6) and weights (7). A horizontal force is applied to the bracket by a mechanically driven measuring stem (8).

46.2 It is especially important that the shear force measuring stem acts on the bracket in the shear plane (plane between base and shear ring) and not above or below this plane.

46.3 The dimensions of the Jenike shear cells supplied by Jenike & Johanson, Inc. are given in the first two columns of the table in Fig. 4. These dimensions have been derived from English units. The standard size Jenike shear cell is made from aluminum or stainless steel, and a smaller 63-mm diameter cell made from stainless steel is also available. Since the actual dimensions are not believed to be critical, the same results could be obtained with a shear cell of the dimensions listed in the third column of the table in Fig. 4. ~~However, it is important 4 or with other shear cells of different sizes provided that the proportions of these dimensions be are maintained approximately when using approximately.~~ In addition, the shear cell diameter must be at least 20 times the maximum particle size of different sizes, the bulk solid being tested. Besides the shear cell, the complete shear tester includes a force transducer which measures the shear force F_s , an amplifier and a recorder, a motor driving the force measuring stem, a twisting wrench, a weight hanger, a time consolidation bench, an accessory for mounting wall material sample plates, and a calibrating device. A spatula having a blade at least 50 % longer than the diameter of the shear cell, and at least a 10-mm width, is needed. The force transducer should be capable of measuring a force up to 500 N with a precision of 0.1 % of full scale. The signal from the force transducer is conditioned by an amplifier and shown on a recorder. The motor driving the force measuring stem advances the stem at a constant speed in the range from 1 to 3 mm/min. The original Jenike shear tester has a speed of 2.72 mm/min when the power supply is 60 Hz. As an alternative to the twisting wrench, some shear testers are supplied with a twisting device in which the twist is applied by means of a shaft passing through bearings. In this way, the likelihood of off-axis nonvertical forces or extra forces being generated during twisting is minimized. Another alternative is to have the motor pull the force measuring stem instead of pushing it. When using any such alternative methods, it is essential that the user ensure that no measurement deviations are introduced.

46.4 The consolidation bench consists of several stations for time consolidation tests. One station is shown in Fig. 5. The station is equipped with a weight carrier (14) on which the weights may be placed and a flexible cover (15) to constrain the test cell and prevent any influence from environmental effects such as evaporation or humidification during time consolidation.

46.5 The arrangement for wall friction tests is shown in Fig. 6. For these tests it is convenient to have a special shear lid with a longer pin and bracket to permit a longer shear distance. Several coupons of typical wall materials should be available. When using the standard size shear cell, each coupon should be approximately 120 mm × 120 mm.

46.6 A device for calibrating the force transducer is shown in Fig. 7. It consists of a pivot (1) around which levers of equal length, (2) and (3) rotate. With counterweight (4) the device is balanced to have its neutral position as shown in the figure. ~~The~~ Lever (2) exerts a force to the force measuring stem corresponding to the weights (5) which are hung on the lever (3). The calibration curve is used to convert the recorder reading to the applied shear force.

4.7 The

6.7 A laboratory balance having a maximum capacity of at least 10 N with a precision of 1 % or better is required.

6.8 The laboratory used for powder testing should be free of vibrations caused by traffic or heavy machinery. Ideally, the room should be temperature and humidity controlled, or, if this is not possible, it should be maintained at its nearly constant ambient conditions. Direct sunlight, especially on the time consolidation bench, is to be avoided.

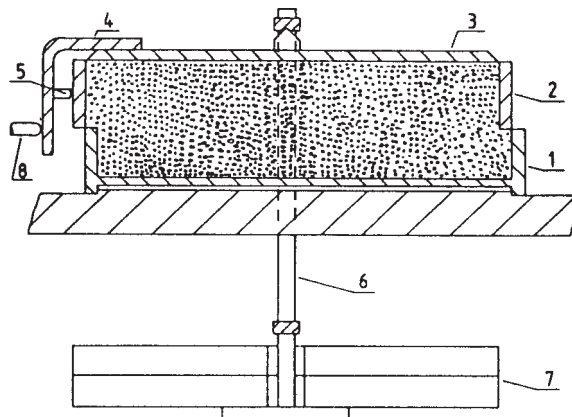

FIG. 1 Jenike Cell in Initial Offset Position

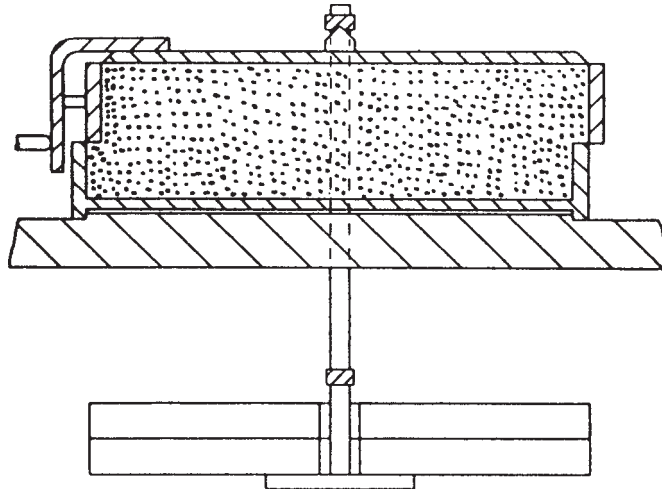

FIG. 2 Jenike Cell in Final Offset Position

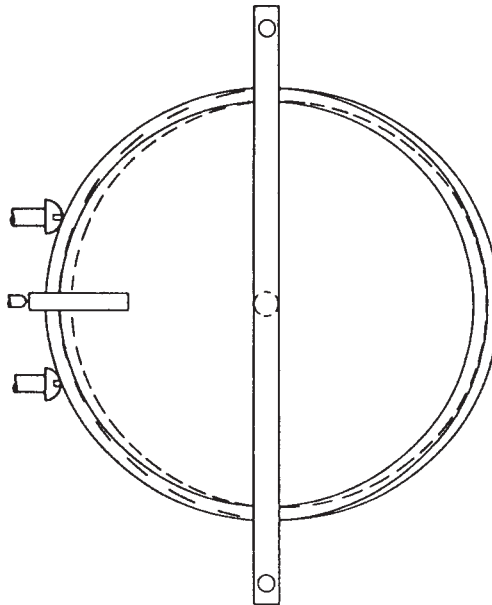

FIG. 3 Plan View of Jenike Cell Showing Offset

NOTE 1—Temperature- and humidity-sensitive materials may need to be tested at different temperatures and moisture contents, because this often happens in industrial environments. The laboratory environment must approximate production for meaningful testing.

57. Specimen Preparation

57.1 Filling the Cell (Fig. 8):

57.1.1 Place the shear ring on the base in the offset position shown in Fig. 1 and gently press the ring with the fingers against the locating screws (10) as shown in Fig. 3 and Fig. 9. Set these screws to give an overlap of approximately 3 mm for standard cell sizes and to ensure that the axis of the cell is aligned with the force measuring stem. Then place the mould ring (11) on the shear ring.

57.1.2 Fill the assembled cell uniformly in small horizontal layers by a spoon or spatula without applying force to the surface of the material until the material is somewhat over the top of the mould ring. The filling should be conducted in such a way as to ensure that there are no voids within the cell, particularly at “a” (Fig. 8) where the ring and the base overlap. Remove excess material in small quantities by scraping off with a blade (1). The blade should be scraped across the ring in a zig-zag motion. Take care not to disturb the position of the ring on the base. For scraping, a rigid sharp straight blade should be used, and, during scraping, the blade should be tilted as shown in Fig. 8.

57.2 Preconsolidation:

57.2.1 Place the twisting or consolidation lid (12) shown in Fig. 9 on the leveled surface of the material in the mould, then place the hanger (6) on the twisting lid with weights (7) of mass $m_{W/w}$ being hung from the hanger. See Fig. 1. Lower the lid, hanger, and weights as slowly as possible to minimize aerated material being ejected from the cell.

	JENIKE STANDARD	JENIKE SMALL SIZE	STANDARD SIZE
D/mm	95.25	63.5	95
H _b /mm	12.7	9.525	13
H _r /mm	15.875	11.113	16
H _m /mm	9.525	7.938	10
T/mm	3 or greater	3 or greater	3 or greater
Material	Stainless Steel or Aluminum	Aluminum	Stainless Steel or Aluminum

GROOVES: 1 mm wide, 90° Included angle

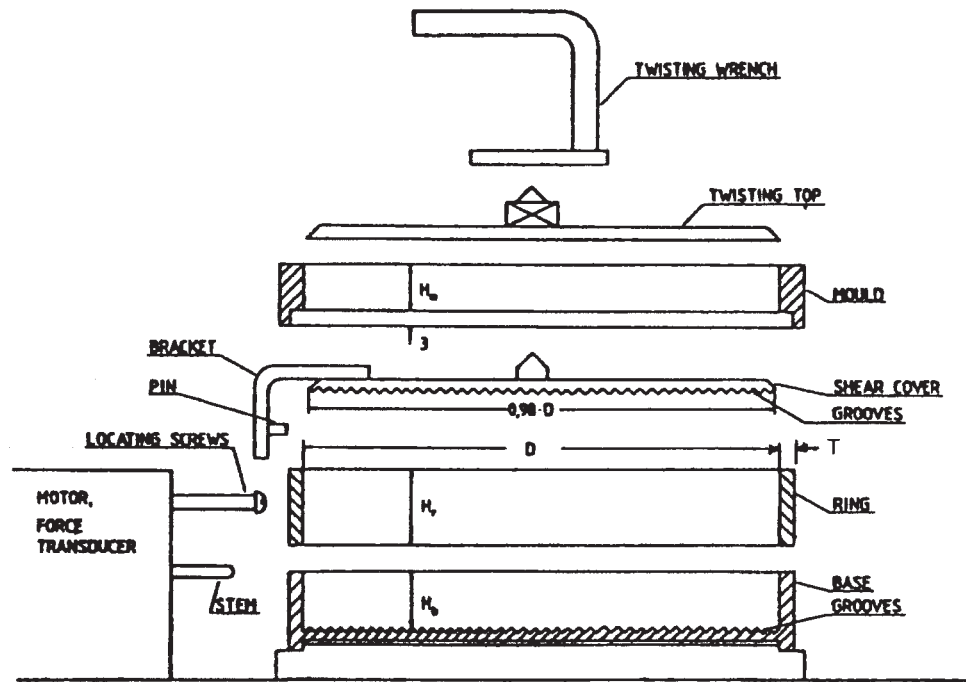

FIG. 4 Dimensions of the Jenike Cell

7.2.2 Visually observe the vertical movement of the lid as the material of the cell is compressed. Wait until this movement appears to stop.

7.2.3 Remove the weights, hanger, and twisting lid. Fill and level the space above the compressed material as during filling.

NOTE 1—During this operation the material is compressed. With fine particulate solids it is necessary to wait until the vertical movement stops.

5.2.2 Remove the weights, hanger, and twisting lid. Fill and level the space above the compressed material as during filling.

NOTE 2—As will be mentioned later, this refilling procedure may not be necessary at all or may need to be performed several times, depending on the compressibility of the powder being tested. This operation determines what height of compacted material will have to be scraped off the ring after twisting.

57.3 Twisting:

57.3.1 Place the twisting lid (12) with a smooth bottom surface on the leveled surface of material in the mould after filling or refilling. Place the hanger with weights of m_{wtw} on the twisting lid. The weights on the hanger should correspond to a pressure of σ_{tw} , approximately equal to σ_p .

7.3.2 Empty the cell and repeat the filling operation if the surface of material in the cell does not appear to the naked eye to be level.

7.3.3 Having filled the cell, the twisting lid is usually twisted through 20 cycles by means of the twisting wrench (spanner) (13) or twisting device. Each twisting cycle consists of a 90° rotation of the lid which is then reversed. Care must be taken not to apply vertical forces to the lid during twisting. While twisting, press the ring against the locating screws with the fingers to prevent it from sliding from its original offset position.

NOTE 3—If the surface 3—The mould and ring should be allowed to rotate freely and independently of material in each other. The rotation of the cell is seen to ring may be not level, then small but has an influence on the filling procedure was consolidation.

7.3.4 If the shear apparatus is not fitted with a special twisting device, the twisting is performed by holding the wrench in one

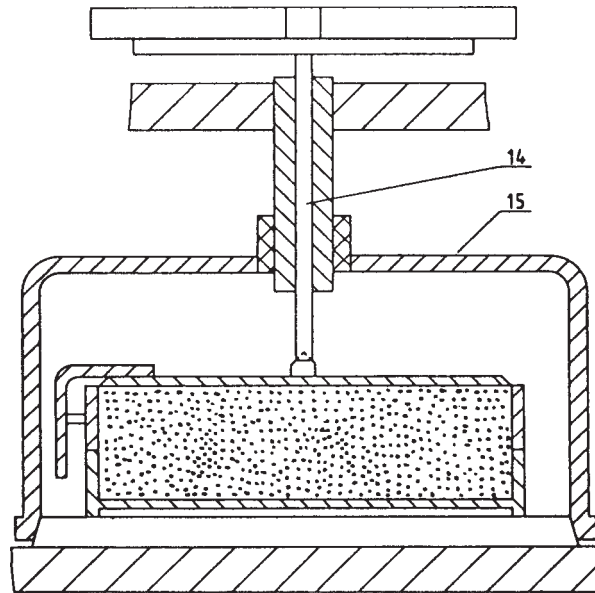

FIG. 5 Consolidating Bench Station

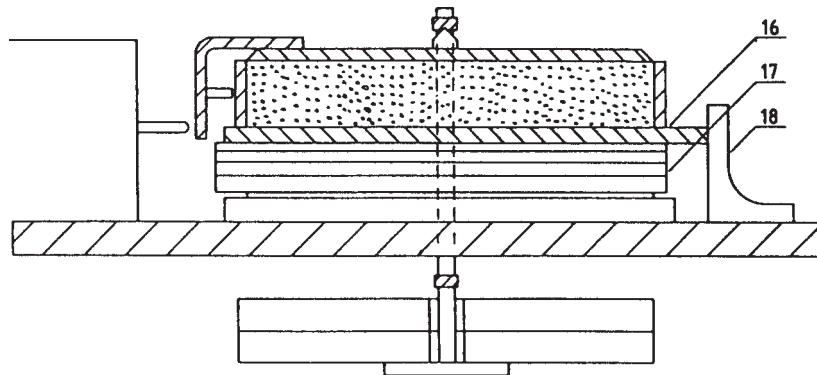

FIG. 6 Wall Friction Test

hand and using the filling operation will have thumb and forefinger of the other to be repeated.

5.3.2 Having filled maintain the cell, ring in the offset position against the locating screws (2) shown in Fig. 8. The twisting lid is usually twisted through 20 cycles by means operation should be smooth and continuous, without jerks, and at the rate of about one twist per second. It is useful to mark the twisting wrench (spanner) (13) shear cell or twisting device. Each twist consists of device to ensure a 90° rotation. After twisting, carefully remove the lid which is weights and hanger, then reversed. Care must be taken not to apply vertical forces to hold the lid during twisting. While twisting, press in position by light finger pressure and carefully remove the mould. Slide the lid off the material in the cell, sliding it in the direction of the force measuring stem so that the shear ring is kept pressed in position against the locating screws with the fingers to prevent it from sliding from its original offset position. screws.

NOTE 4—The mould and compacted material above the ring should be allowed to rotate freely and independently of each other. The rotation of evenly distributed if the ring may be small but filling has an influence on been satisfactory. The material remaining above the consolidation.

5.3.3 If the shear apparatus is not fitted with a special twisting device, the twisting is performed by holding the wrench in one hand and using the thumb and forefinger of the other to maintain the ring in the offset position against the locating screws (2) shown in Fig. 8. The after twisting operation should be smooth and continuous, without jerks, and at the rate of about one twist per second. It is useful from 1 to about 3 mm thick.

7.3.5 Discard the shear cell or twisting device to ensure test specimen and prepare a 90° rotation. After new one if, after twisting, carefully remove the weights and hanger, then hold material surface is below the lid in position by light finger pressure and carefully remove top of the mould. Slide the lid ring.

7.3.6 Scrape off the excess material in small quantities to be flush with the cell, sliding it in the direction top of the force measuring stem so that the shear ring is kept pressed using a blade in position against the locating screws. same way as that shown in Fig. 8. Do not exert downward force by the scraping blade.

NOTE 5—The compacted material above the ring should be evenly distributed if the filling has been satisfactory. The material remaining above the ring

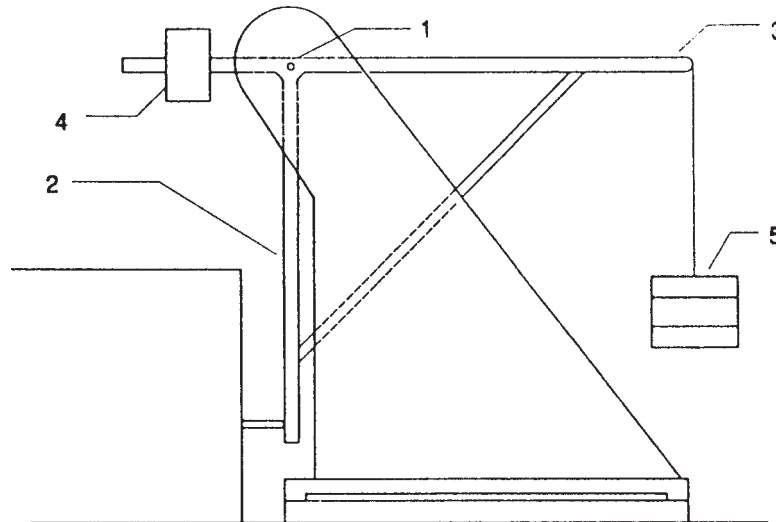

FIG. 7 Calibration Device

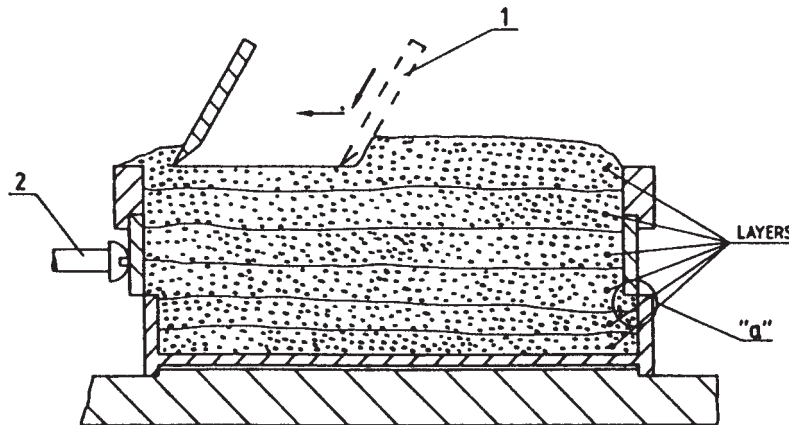

FIG. 8 Scraping Off Excess Powder

after twisting should be from 1 to about 3 mm thick. If after twisting the material surface is below the top of the ring, then it is necessary to prepare a new test specimen by using one more filling of the cell.

5.3.4 Scrape off excess material in small quantities to be flush with the top of the ring using a blade in the same way as that shown in Fig. 8. Do not exert downward force by the scraping blade.

NOTE 6—If 5—If coarse particles are present, scraping may tear them from the surface and alter the structure. In such cases, it is better to attempt to fill the cell so that the material surface is flush with the ring after consolidation. Care must again be taken not to displace the shear ring from its original offset position.

68. Procedure

68.1 Shear Testing Procedure:

68.1.1 Synopsis:

68.1.1.1 Place the shearing lid centrally on the leveled surface of material with the pin of the bracket within 1 mm of the ring. Make sure that the bracket of the shear lid is in line with the force measuring stem. Place weights m_{wp} corresponding to σ_p on the hanger, and gently lower the hanger with weights as slowly as possible onto the shear lid so as to not jar the specimen. Steady the hanger to prevent any visible swinging motion. Switch on the motor driving the force measuring stem, and perform a shear test for the full shear distance of approximately 6 mm from the offset position in Fig. 1 to the offset position in Fig. 2 for standard cell sizes. Record the shear force, F_s , for the whole shear distance.

NOTE 7—During shear, a shear zone develops in the specimen of particulate solid in the cell. Since the stem advances at a steady rate, the record of shear force versus time can be transformed into a shear force – shear strain plot.

6.1.1.2 Perform a shear test for

8.1.1.2 Inspect the whole shear distance and inspect the shear force – shear strain plot. If the specimen is found to be underconsolidated, or overconsolidated, remove the specimen and repeat the procedure beginning at 7.1. If the specimen is found

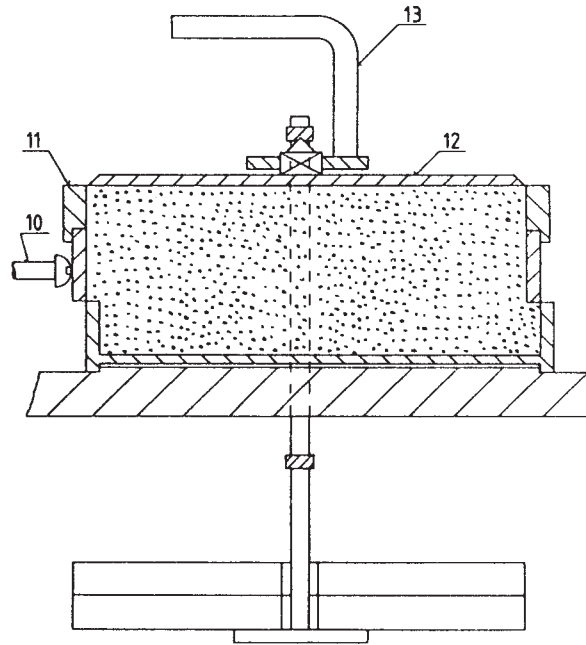

FIG. 9 Jenike Cell With Mould Ring and Consolidation Lid

to be underconsolidated, increase the number of twists applied to the lid, then increase the weight m_{Wtw} in accordance with A3.10. If the specimen is overconsolidated, first decrease the number of twists, then reduce the weight m_{Wtw} in accordance with A3.11.

NOTE 87—In such a manner, it is possible by trial and error, to find a combination of weight, m_{Wtw} , and the number of twists so that for the selected weight, m_{Wp} , the shear force—shear strain plot indicates the presence of a critically consolidated specimen. This operation is called optimization. See Annex A3.

NOTE 98—Each shear test gives one point on a yield locus and consists of preshear and shear. Changes in the preconsolidation procedure may affect the yield locus derived from this test.

NOTE 10—The force measuring stem measures the shear force in the shear plane between the base and ring, and; hence, the corresponding normal force has to be determined in this plane. In the Jenike shear cell this normal force, F_v , is a vertical force produced by the combined masses of:

- Weights, m_W
- Hanger, m_H
- Shear Lid, m_L
- Ring, m_R
- Material in the shear ring above the shear plane, m_B

NOTE 110—The shear ring is included in the vertical force since during shear the material dilates in the shear zone, as a result of which all material above the shear plane is lifted slightly. Since the material is constrained in the shear ring, any dilation of the cell contents brings about a lifting of the ring such that the weight of the ring is supported by the material in the ring rather than by the cell base. For preshear, this is not strictly so, because part of the weight of the ring may be transferred to the base. Therefore, because during preshear that portion of the weight of the ring transferred to the base is uncertain, the weight of the ring is included in the weights contributing towards the total normal force when calculating the preshear normal force. The influence of the ring-base contact on the shear and normal force can be avoided by carefully lifting the shear ring less than 1 mm and twisting it through a couple of degrees prior to shear while the shear lid has a weight applied to it.

68.1.2 Preshear:

68.1.2.1 The first part of the shear test consists of preparing a critically consolidated specimen by optimized twisting and then preshearing the specimen with a selected weight, m_{Wp} , to develop a shear zone in which steady state flow occurs.

68.1.2.2 Select the first preshear normal stress, $\sigma_{p,1}$, on the basis of the bulk density of the test material, in accordance with the following table:

ρ (kg/m ³)	$\sigma_{p,1}$ (kPa)
ρ_b (kg/m ³)	$\sigma_{p,1}$ (kPa)
< 300	approximately 1.5
300 to 800	approximately 2.0
800 to 1600	approximately 2.5
1600 to 2400	approximately 3.0
> 2400	approximately 4.0

68.1.2.3 A preliminary estimate of the bulk density can be made by placing the shear ring on a flat surface, packing the particulate solid in the ring with fingers, scraping the solid level with the top, and weighing the contained solid. From the weights and volume of the specimen, calculate the bulk density. Select higher preshear normal stress levels so that:

$$\sigma_{p,2} = 2\sigma_{p,1}$$

$$\sigma_{p,3} = 4\sigma_{p,1}$$

$$\sigma_{p,4} = 0.8\sigma_{p,1}$$

6.1.2.4 First perform tests using a preshear normal stress level of $\sigma_{p,1}$ and then with increasing preshear normal stress levels. Select 3 to 5 shear normal stress levels within the range from 25 to 80 % of the preshear normal stress levels. Each measurement should be performed twice.

NOTE 12—Some adjustment in preshear normal stress levels may be necessary in order to cover the range of major consolidation stresses, σ_1 , necessary to accurately calculate critical arching or ratholing dimensions, or both.

6.1.2.5 At density.

8.1.2.4 At the selected preshear normal stress prepare a nearly critically consolidated specimen and start preshear. The shear stress rises (Fig. 10) and attains the steady state value τ_p . Maintain this shear stress in the shear cell through a relatively short shear distance (about 0.5 mm) to ascertain this value and then reverse the forward motion of the force measuring stem until the stem loses contact with the bracket (that is, the shear force falls to zero) value.

NOTE 131—The steady state shear stress τ_p may be attained after relatively little shear, even before the shear ring and base completely overlap. With some materials a greater amount of shear may be necessary to attain steady state shear. However, the steady state shear stress should be attained after a maximum shear distance corresponding to three fourths of the total available.

8.1.2.5 Constancy of the values of the steady state shear stress τ_p obtained after preshear is an indication of the reproducibility of consolidation. With correctly consolidated samples, individual values of the steady state shear stress should not deviate by more than $\pm 5\%$ from the average steady state shear stress for the given preshear normal stress. With some particulate solids, however, this tolerance cannot be achieved. If this happens, it should be noted by the technician performing the test.

6.1.3 Shear:

6.1.3.1 Having attained a steady state flow condition, retract reverse the forward motion of the force measuring stem causing until the stem loses contact with the bracket, that is, the shear force falls to zero zero, (Fig. 10). For the second stage select a shear normal stress level σ_s within the range of 25 to 80 % of the preshear normal stress level σ_p , and replace the weight m_{wp} by a smaller weight m_{ws} and switch. Switch on the motor again to drive the measuring stem in the forward direction.

NOTE 142—When the stem touches the bracket, the shear force rapidly increases, goes through a maximum representing the yield shear force, and then begins to decrease. This part of the test is called shear.

NOTE 153—Shear may be continued until the whole overlap distance of the cell has been traversed in order to develop a distinct shear plane. The value τ_s is the shear stress at failure peak (shear point) for the selected shear normal stress σ_s at the selected preshear normal stress σ_p . When reducing the normal stress before shear, it is recommended that weights be removed from the hanger until the required weight is left. If the test is to be carried out at low shear, and hence low normal stress levels, it may be necessary to remove the hanger and place the weights directly on the lid. The whichever procedure is followed, the weights should be removed and replaced in a gentle manner in whichever procedure is followed.

6.1.3.2 After manner.

8.1.3.2 After each shear test, determine calculate the overall bulk density of the specimen by weighing determining the mass of the specimen with the base, shear ring, and shear lid.

NOTE 164—Since the weights mass of base, ring, and lid are known and also the volume of the cell can be determined, the overall bulk density, ρ_b ,

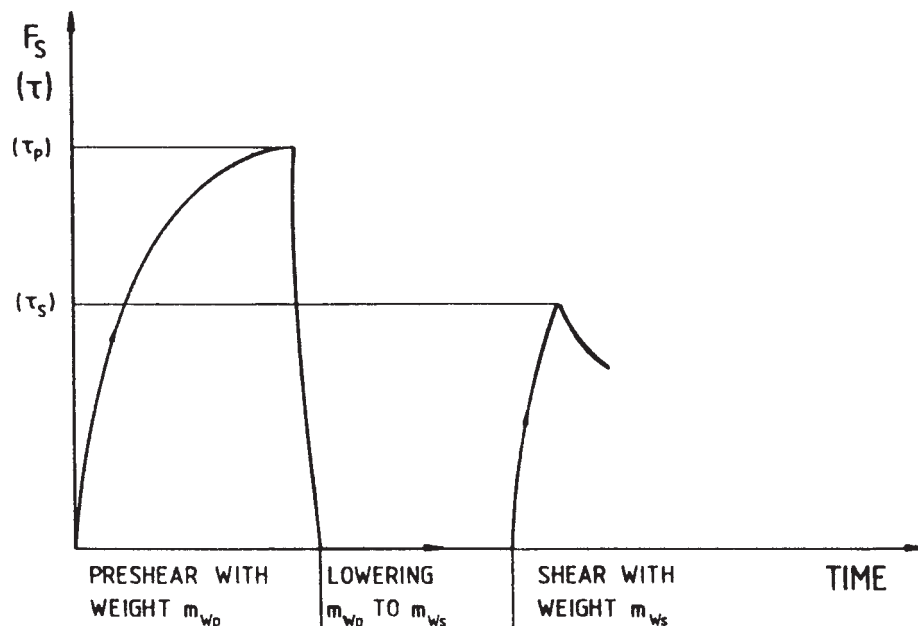

FIG. 10 Stress-Strain Curves — Preshear and Shear

of the specimen can be calculated. The value of the bulk density of the specimen after the shear test gives an indication of the reproducibility of specimen preparation.

68.1.3.3 After each shear test (and weighing), lift the shear ring with shear lid and material contained within the ring from the base and inspect the plane of failure.

8.1.3.4 If the plane of failure cuts diagonally across the particulate solid either up to the shear lid or down to the bottom of the base, the test is invalid and will have to be repeated.

NOTE 17—If the plane of failure cuts diagonally across the particulate solid either up to the shear lid or down to the bottom of the base, the test is invalid and will have to be repeated. If 15—If an invalid plane of failure persists, further tests at the given and lower shear normal stress levels cannot be performed and shear tests can be made only at higher shear normal stresses. In such a case, the intervals between the shear normal stress levels may have to be reduced to obtain the necessary minimum of three shear points on the yield locus. If the material is free flowing it may be impossible to observe the plane of failure.

8.1.4 *Additional Tests:*

8.1.4.1 Repeat 7, 8.1.2 and 8.1.3.

8.1.4.2 Select 3 to 5 shear normal stress levels σ_s within the range of 25 to 80 % of the preshear normal stress level σ_p , and repeat 7, , 8.1.2.4, 8.1.3, and 8.1.4.1.

8.1.4.3 Select higher preshear normal stress levels so that:

$$\begin{aligned} \sigma_{p,2} &= 2\sigma_{p,1} \\ \sigma_{p,3} &= 4\sigma_{p,1} \\ \sigma_{p,4} &= 8\sigma_{p,1} \end{aligned}$$

NOTE 16—Some adjustment in preshear normal stress levels may be necessary in order to cover the range of major consolidation stresses σ_1 necessary to accurately calculate critical arching and/or ratholing dimensions.

8.1.4.4 Repeat 7, 8.1.2, 8.1.3, and 8.1.4.2 for each selected preshear normal stress level.

8.1.5 *Prorating:*

68.1.45.1 Ideally, all values of the preshear shear stress, τ_p , for a given preshear normal stress would be identical. This would occur if the specimen was perfectly homogeneous, and specimen preparation completely repeatable. However, because of unavoidable experimental variation there is a scatter of τ_p values which affects the value of the shear stress, τ_s .

68.1.45.2 To minimize the scatter, all measured shear stresses, τ_s , may be corrected to take into account scatter in the preshear shear stresses, τ_p . This empirical procedure is called prorating, and prorated values of τ'_s of the measured values τ_s are evaluated using the following equation:;

$$\tau'_s = \tau_s \frac{\bar{\tau}_p}{\tau_p} \tag{1}$$

where $\bar{\tau}_p$ = average of the preshear, shear stresses, τ_p , of the corresponding preshear normal stress level (yield locus). Prorating assumes that variations in consolidation produce variations in shear stress, τ_s , that are proportional to the corresponding variation in preshear shear stress, τ_p .

6.1.5—

8.1.6 *Determination of Valid Shear Points:*

68.1.56.1 For each consolidation condition (σ_p), plot prorated and averaged shear points S_T ($\sigma_s, (\tau'_s)$) of repeated measurements and the averaged preshear point $P_i(\sigma_p, \bar{\tau}_p)$ on a σ, τ -diagram (Fig. 11).

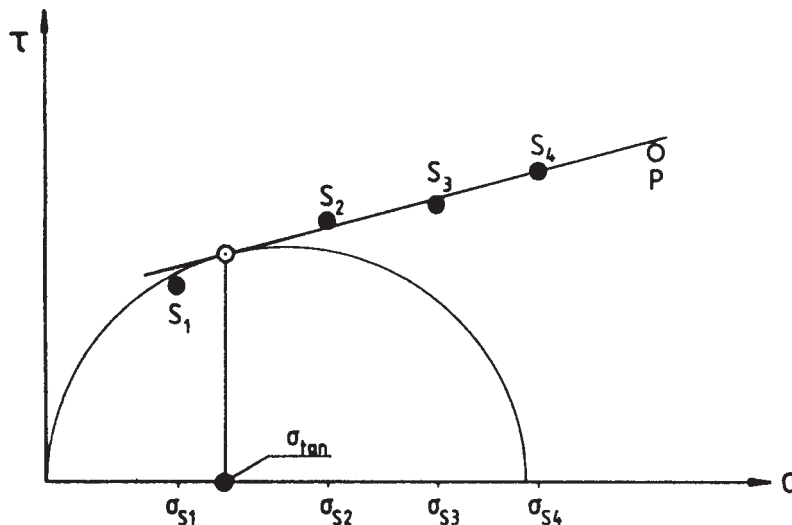

FIG. 11 Yield Locus and Data Points

6.1.5.2 Adopt the following procedure to

8.1.6.2 To determine whether a yield point is valid, the following procedure is adopted.

68.1.56.3 Fit by means of a least squares fit a straight line called the yield locus, YL , to the three highest points S_2 , S_3 , and S_4 (Fig. 11). ~~NOTE 18—If~~

8.1.6.4 If the straight line passes through or above Point P , it can be used for further calculation. If, however, the straight line passes below Point P but the deviation in shear stress (between the steady state value and the extrapolated value based on the yield locus YL) is less than 5 % (Fig. 12), it should be replotted to pass through Point P and refitted to the points S_2 , S_3 , and S_4 (Fig. 13), and this new straight line should be used for further calculations. If the deviation is more than 5 %, either additional shear points should be run or the test should be redone at a different level of consolidation.

NOTE 197—From an inspection of the σ, τ -diagram, it can be seen that the shear points on a yield locus are not equally spaced from zero normal stress to preshear normal stress, but begin at a certain minimum value of normal stress and end some distance before the preshear normal stress is reached. Considering the situation in more detail, Fig. 14 shows one yield locus with a preshear point P and four valid shear points, S_1 – S_4 . One Mohr circle, 1, (the steady state Mohr circle) is drawn through the preshear Point P and tangentially to the extrapolated yield locus (the point of tangency is shown on Fig. 14 as B and defines the end point of the yield locus).⁴ A second Mohr circle, 2, (the unconfined strength Mohr circle) is drawn, passing through the origin and tangential to the extrapolated yield locus (this point of tangency is denoted by A in Fig. 14). ~~Valid yield~~ Yield points to be considered must lie between the points of tangency A and B . Points to the right of B may be valid or invalid; thus, for the purpose of this test method, they are ignored.

NOTE 2018—Points to the left of Point A are ~~invalid~~ ignored because they represent a state where tensile stresses can occur in the shear cell. This can be seen by considering the yield point on Fig. 14 marked by $S_{(-)}$, below Point A . If a Mohr circle 3 is drawn through this point, which is tangential to the extrapolated yield locus, part of that circle will lie to the left of the origin indicating negative normal stresses, that is, tensile stresses.

68.2 Shear Testing Procedure for Time Consolidation:

68.2.1 When a particulate solid is exposed to a normal or compressive stress for some time it may gain strength. This gain in strength may be measured in the Jenike shear cell, and the effect is called time consolidation.

6.2.2 To gain an understanding

8.2.2 Time consolidation is carried out using a consolidating bench, which consists of several shear cells that can be loaded independently. The time that the specimens sit at rest is specified according to the application.

NOTE 19—As an alternative to using a consolidation bench, consider the following experiment. A following: a critically consolidated specimen is prepared and presheared by preshearing with weight m_{wp} . After attaining steady state flow the advance of the force measuring stem is stopped but the stem is not retracted. The shear zone formed thus remains under the normal and shear stresses corresponding to steady state flow and is kept in this state for a definite time, t . If the stem is then retracted, the shear force will drop to zero, and the actual shear test may be performed in the usual way. It is found that with materials which gain strength during time consolidation, a higher shear strength will be measured. In a σ, τ -diagram, the time yield locus for time consolidation will lie above the instantaneous flow yield locus:

6.2.3 If locus. If the effect of time consolidation in the Jenike shear cell were measured as previously described, in this manner, one test would monopolize the shear cell for a very long time. Also, creep of the specimen could cause a decrease in the applied shear force during the resting phase.

6.2.4 Time consolidation tests are therefore carried out using a consolidating bench which consists of several shear cells which can be independently loaded.

6.2.5—

8.2.3 Specimen preparation and preshear time effects—After completion of instantaneous testing and evaluation, perform time tests at the same preshear normal stress levels.

⁴ This method of constructing the steady state Mohr circle is specified by the EFCE and Jenike. Alternative methods of construction have been proposed. See for example, Peschl.

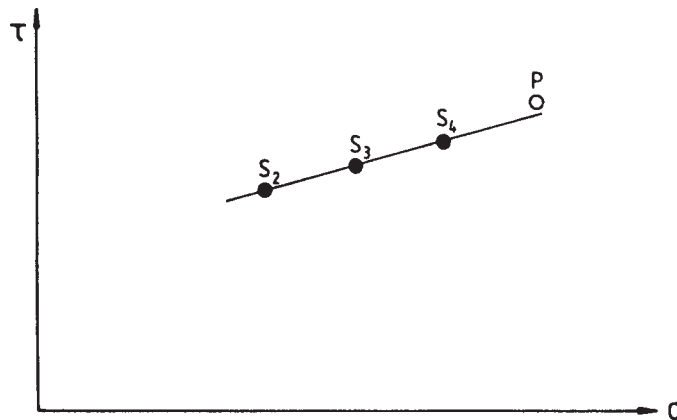

FIG. 12 End Point Above Fitted Line

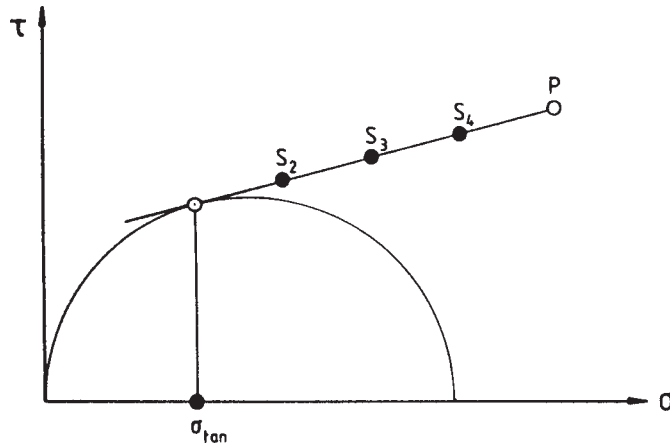

FIG. 13 End Points on Fitted Line

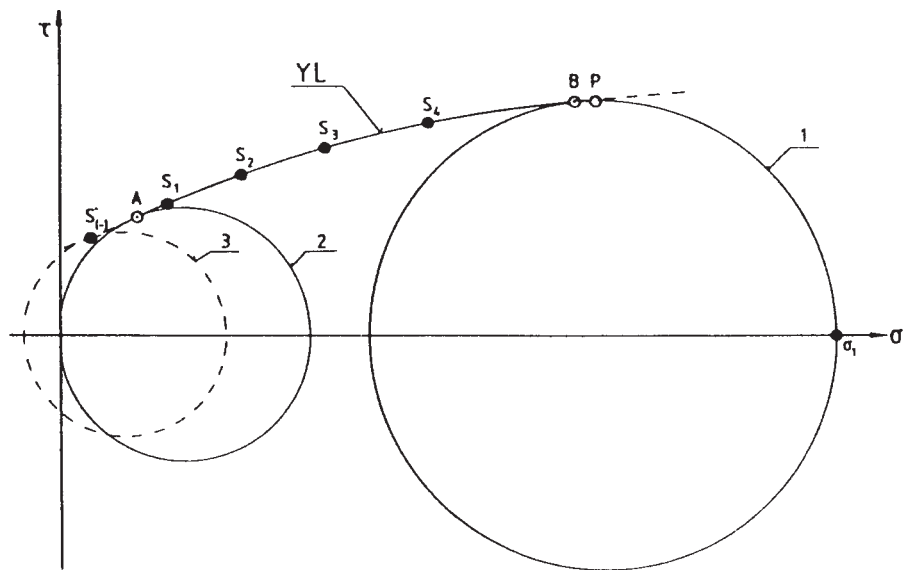

FIG. 14 Yield Locus Showing Valid Shear Points

NOTE 210—For a selected preshear normal stress, specimen preparation and preshear are the same as for the instantaneous test.

6.2.6—

8.2.4 Time Consolidation:

68.2.64.1 Perform the test for time consolidation in the following way. Using the shear tester, prepare and preshear samples with weight m_{wp} in the normal manner and then retract the stem after preshear. Remove the hanger with weights. Then transfer the shear cells (base, shear ring, shear lid, and material) to the consolidating bench. In order to prevent the evaporation or take up of moisture from the ambient environment, place a flexible cover over each cell, and then load each by placing a weight m_{wt} either directly on the lid or by means of a loading rod.

NOTE 221—When the shear cell is transferred from the shear tester to the consolidating bench, care should be taken that the ring is not moved relative to the base. As the weight carrier is lowered on the shear lid, great care must be taken in adjusting the position of the shear cell on the consolidation bench to ensure that the weight carrier acts centrally on the shear lid or on a similarly sized compression plate when the weight carrier is lowered.

68.2.64.2 Select the weight m_{wt} in such a way that the stress state in the specimen during time consolidation is the same as during preshear (that is, steady state flow).

NOTE 232—During preshear a normal stress as well as a shear stress is acting, although on the consolidating bench only normal stresses can be applied. Through nearly 40 years of industrial practice, it has been found that the stress state developed by the application of normal stress alone, however, alone can closely successfully approximate that developed in steady state flow. The Mohr circle shown in Fig. 14 is drawn through Point P (steady state flow) and is tangential to the yield locus. During time consolidation, the specimen is loaded with the major principal stress, σ_1 , of that Mohr circle as shown in Fig. 14.

68.2.64.3 Calculate the mass of the weights to be placed on the weight carrier from:

$$m_{wt} = \frac{A \times \sigma_1}{g} - m_C - m_R - m_L - m_B \quad (2)$$

where

m_c = mass of the weight carrier.

NOTE 243—Since the shear strength after time consolidation is not very sensitive to the force σ_1 , it is sufficient to select m_{wt} to satisfy Eq 2 to within $\pm 5\%$.

68.2.6.4 After the chosen time, t , has elapsed, remove the weights from the weight carrier, raise the flexible cover, raise the weight carrier, and transfer the shear cell to the shear tester.

6.2.7—

8.2.5 *Shear of Specimen After Time Consolidation*—

8.2.5.1 Select a weight m_{ws} . Perform shear in the same manner as for instantaneous flow. For time tests, select no more than three shear normal stress levels for each preshear stress.

NOTE 254—Due to the scatter obtained in time shear tests, it is recommended that they be performed at least twice.

68.2.5.2 Prorate the time shear stress values using the following equation:

$$\tau'_{st} = \tau_{st} \left[\tau'_s \left(\frac{\tau_{pt}}{\tau_p} - 1 \right) \right] \quad (3)$$

where:

τ'_{st} = prorated time shear value of τ_{st}

τ'_s = prorated instantaneous shear value (Eq 1) for the same shear normal stress,

τ_{pt} = preshear shear stress for the time test, and

x_p = average of the instantaneous preshear shear stress values.

8.2.6 *Validity of Time Shear Points*—Plot the time shear points in σ, τ -coordinates (Fig. 15) and draw a straight line called the time yield locus, *TYL*, through the highest shear point and parallel to the instantaneous yield locus (for that particular preshear normal stress level). Draw a Mohr circle through the origin and tangential to this straight line.

NOTE 265—Those time shear points which lie to the right of this point of tangency A_t of the Mohr circle to the straight line time yield locus are considered valid. The normal stress applied at shear for the highest time yield point S_{3t} is generally less than the normal stress applied at the end point, B , of the instantaneous yield locus.

68.3 *Procedure for Wall Friction*:

68.3.1 When measuring the friction between the particulate solid and a coupon of silo wall material in a wall friction test, replace the base of the shear cell by the coupon of wall material. Shear the specimen contained in the upper part of the shear cell (the ring and shear lid) over the wall material coupon under different wall normal stresses σ_w and measure the resulting wall shear stresses τ_w .

68.3.2 *Selection of Wall Friction Normal Stress Levels*—Select six wall friction normal stress levels, σ_{w1} to σ_{w6} , where σ_{w1} is the smallest normal stress. The largest normal stress, σ_{w6} , should be approximately equal to the major consolidation stress, $\sigma_{1,2}$, of the second preshear normal stress, $\sigma_{p,2}$. The smallest normal stress σ_{w1} will normally include the hanger without weights.

68.3.3 *Wall Coupon and Material Specimen Preparation*:

6.3.3.1 The coupon of wall material should be approximately 120 by 120 mm for use with

8.3.3.1 Wash the standard size shear cell. Wash the wall material coupon and dry thoroughly before the test. Do not touch the surface after washing by the bare hands. Rub the particulate solid under test onto the surface of the wall coupon by hand, wearing gloves.

6.3.3.2 Shim hands.

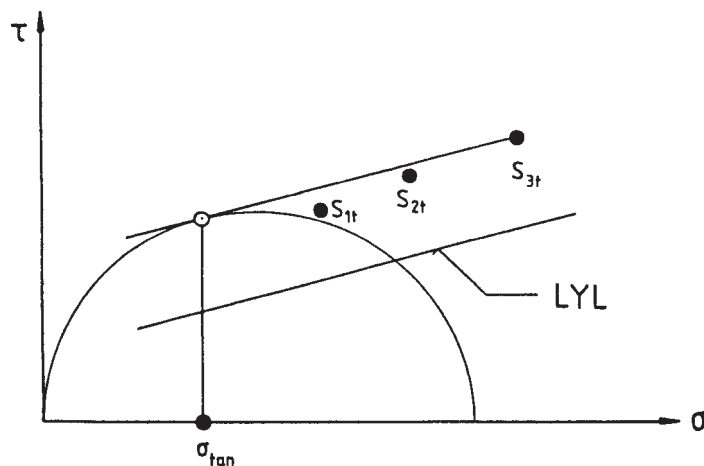

FIG. 15 Validity of Points on the Time Yield Locus

8.3.3.2 Shim (17) the wall coupons (16) (see Fig. 6) so that the top surface of the coupon is the horizontal plane of the force measuring stem. Place the ring on the wall coupon and set it against the locating screws. Adjust the position of the wall coupon so that it just covers the inside of the shear ring on the stem side and permits maximum travel of the ring over the coupon during the test. Fix the position of the wall coupon (18) (see Fig. 6).

8.3.3.3 Place the mould ring on the shear ring, and fill the shear ring and mould ring with the particulate solid. Scrape excess material flush with the top of the mould ring.

68.3.3.4 Place the twisting lid on the leveled material, place the hanger on the lid, and place weights on the hanger, corresponding to the normal stress, σ_{w6} . Using the twisting wrench, twist the lid to homogenize the specimen. Do not apply vertical stress to the twisting lid by the twisting wrench. During twisting allow the mould ring and the shear ring to rotate. After consolidation, carefully remove the weight hanger and weights from the twisting lid. Hold the twisting lid down lightly with the fingers and remove the mould ring. Carefully remove the twisting lid from the cell by sliding towards the locating screws, and scrape off the caked material level with the top of the shear ring. Observe the same procedure and precautions as for preparation of a specimen for shear testing.

68.3.3.5 If after consolidation, the level of the compressed material is below the top of the shear ring, refill the cell as previously described prior to removing the mould ring.

8.3.3.6 Place the shear lid on the levelled material in the shear ring, aligning the lid with the shear unit stem. Twist and manually lift the ring slightly off the wall material coupon to prevent it from dragging on the wall coupon.

8.3.3.7 Rub the particulate solid under test onto the surface of the wall coupon by applying pressure less than or equal to σ_{w6} by hand to the lid, and sliding the solid across the wall coupon by hand, away from the shear unit stem. Release the pressure and push the cell back to the starting position. Repeat twice.

8.3.4 Wall Friction Tests:

68.3.4.1 Stack weights on the hanger corresponding to the wall friction normal stress σ_{w6} . Include the weight of the hanger in the calculation of σ_w . ~~Then place the shear lid on the leveled material in the shear ring and place~~ Place the hanger on the lid. Select the weights in such a way that by removing a weight (or weights) the normal stress is reduced stepwise from $\sigma_{w(i+1)}$ to σ_{wi} .

8.3.4.2 Check to make sure that the ring is not touching the wall coupon. If it is, twist and manually lift the ring slightly off the wall material coupon to prevent it from dragging on the wall coupon. Then, switch on the motor driving the force measuring stem.

NOTE 276—As the shear starts, the shear stress will begin to rise. It will approach a steady state either directly or may pass through a maximum.

6.3.4.2 When

8.3.4.3 Determine by visual inspection of the recorder chart when the shear stress; τ_{w6} ; has reached a constant value;. Then remove weight(s) until the normal stress is reduced to σ_{w5} . Continue to advance the stem during removal of the weights. ~~The shear stress, τ_{w6} , is sometimes ignored.~~ When the shear stress has again reached a constant value, record the shear stress, τ_{w5} , and remove more weights to reduce the normal stress to σ_{w4} . When the shear stress has again become constant, record the stress τ_{w4} . Continue this procedure over the range of selected normal stresses.

68.3.4.34 If the stem has reached the limit of its travel before the whole range of required normal stresses has been tested (say at normal stress σ_{wi}), retract the stem, remove the normal load on the cover, carefully push back the ring to the locating screws, increase the normal stress to $\sigma_{w(i+1)}$ and continue testing, ignoring the first (repeated) reading of $\tau_{w(i+1)}$.

68.3.4.45 On completion of the tests, weigh the specimen to determine m_B .

68.3.4.56 Repeat wall friction tests two to three times with new samples of the particulate solid.

NOTE 287—Sometimes there will be a rapid oscillation of the indicated shear force because of slip-stick behavior. The shear stress maxima recorded during shear will be used to evaluate the wall friction angle ϕ' .

NOTE 298—In many cases there is no distinct difference between static and kinematic friction. However, the shear force may pass through a maximum when starting a wall friction test, that is, there is a peak shear stress at τ_{w6} . If static friction is suspected, the static angle of wall friction can be determined as follows: A test is performed as previously described, but when the shear force has passed through the maximum the stem is retracted. After the shear force has fallen to zero, the weight on the hanger is reduced and the motor is started again. The shear force will again pass through a maximum, and the procedure of retracting the stem and reducing the weight is repeated. The peak values of τ_w are used to evaluate the static angle of wall friction.

68.4 Wall Friction Time Tests:

68.4.1 Static wall friction tests with time consolidation are also known as adhesion tests.

68.4.2 Cut three coupons of the same wall material to fit under the covers of the consolidating bench and wash and dry them thoroughly.

68.4.3 Perform a wall friction test using wall friction normal stresses, σ_{w6} to σ_{w1} , to obtain a defined compaction of the particulate solid particles. Retract the stem and push back the shear ring against the locating screws. Increase the load to σ_{w6} and perform a shear test until the shear stress attains a constant value. Without stopping, remove shear weights to obtain the stress σ_{w5} . When the shear stress again reaches a constant value, stop and retract the stem.

NOTE 3029—This step can be considered as wall friction 'preshear' which gives the 'initial' shear stress τ_{wp5} .

68.4.4 Remove the weights and hanger and very carefully place the wall coupon with material specimen, shear ring, and shear lid onto the consolidating bench under the cover.

NOTE 3†0—At this time, the material specimen will have little or no adhesion to the wall plate and may move slightly. This, however, does not negate the test.

68.4.5 Using the weight carrier or hanger with appropriate weights, apply the normal stress, σ_{w5} . If a weight carrier is used, calculate the appropriate weights required using Eq 2.

68.4.6 After the chosen time, t , has elapsed, transfer the wall coupon with material specimen, shear ring, and shear lid to the shear tester. Take care not to bump the specimen during this transfer as any break in the adhesive bond will nullify the test. Using the weight hanger and weights, load the shear lid to give a normal stress σ_{w5} and perform shear in the normal way. The shear stress will pass through a maximum, the 'time' wall friction shear stress, and is given the symbol τ_{wt5} .

68.4.7 The pair of stresses (σ_{w5} , τ_{wt5}) define Point S_{w5} . Using the second wall coupon, obtain another point (σ_{w3} , τ_{wt3}) by preshearing the specimen under normal stresses of σ_{w4} and σ_{w3} and time consolidate it at σ_{w3} as previously described. Obtain a third point (σ_{w1} , τ_{wt1}) using the normal stresses, σ_{w2} and σ_{w1} , for preshear and σ_{w1} for time consolidation. Further points (σ_{w4} , τ_{wt4}) and (σ_{w2} , τ_{wt2}) can be measured using the same procedure.

79. Calculation or Interpretation of Results

79.1 Data Processing for Instantaneous Shear Tests:

79.1.1 Evaluate results separately for every chosen value of the preshear normal stress, although all points should be shown on one σ, τ -diagram.

79.1.2 Plot the preshear point, P , and all valid shear points for one given preshear normal stress level in σ, τ -coordinates. Draw a smooth line through the valid points and extrapolate it to the preshear normal stress. If this line passes above or through Point P , use it for further calculations. If it passes below Point P , plot a new line passing through Point P and fit it to all the valid yield points.

79.1.3 Draw a Mohr circle through the origin, tangential to this smooth line, the instantaneous yield locus (YL in Fig. 16).

NOTE 32†1—The higher point of intersection of this Mohr circle with the σ -axis is the unconfined yield strength, f_c .

79.1.4 Draw a second Mohr circle through Point P , tangential to the smooth line in such a way that the point of tangency is to the left of the preshear Point P .

NOTE 33†2—The upper point of intersection of this Mohr circle with the normal stress axis is the major consolidation stress, σ_1 . In this way, the pair of values, f_c and σ_1 , associated with this particular yield locus are produced, these values all being associated with the major consolidation stress σ_1 .

NOTE 34†3—The yield locus is normally found to show a small curvature, convex upwards. With many particulate solids, a straight line is a sufficient approximation. If the yield locus is approximated as a straight line for all particulate solids, then subsequent calculations are much simpler, but, in some cases, somewhat conservative results may be obtained, that is, a higher f_c value will be determined than when using a fitted curve.

79.1.5 Determine the angle of internal friction of the particulate solid, ϕ_i , at the major consolidation stress, σ_1 , by measuring the angle between a yield locus and the σ -axis.

NOTE 35†4—Since this angle varies with σ when using a smooth line yield locus, its value should be read from the linearized yield locus (LYL), which is the tangent to the two Mohr circles characterizing the major principal stresses σ_1 and f_c (Fig. 16).

79.1.6 Draw a straight line through the origin, tangential to the major principal stress Mohr circle. This line, which is the effective yield locus (EYL), forms an angle δ with the axis, called the effective angle of friction. For a given preshear normal stress and value of σ_1 , determine a mean bulk density, ρ_b .

NOTE 36†5—The preceding calculation produces values of f_c , ϕ_i , δ , and ρ_b for a given σ_1 . By making measurements at several preshear normal stresses,

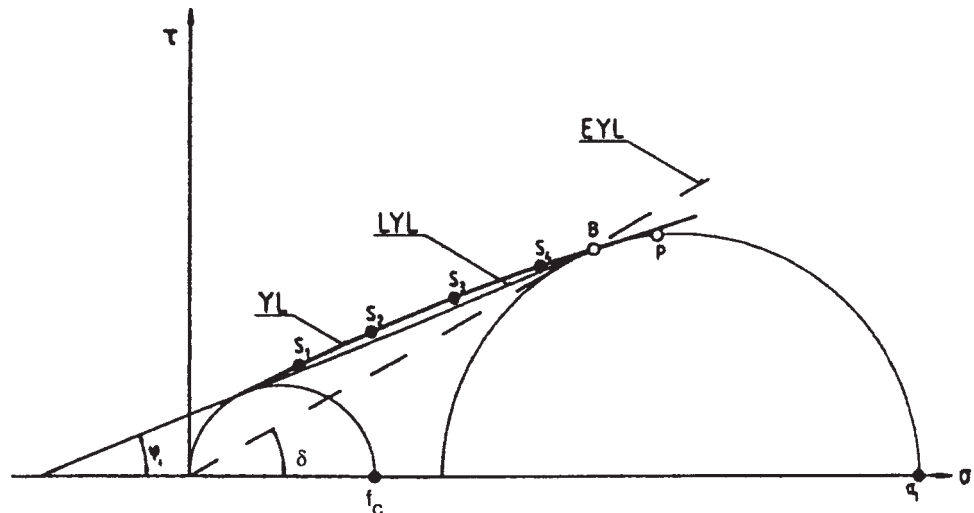

FIG. 16 Mohr Circles, Angles of Friction and Yield Loci

the dependencies of f_c , ϕ_i , δ , and ρ_z on σ_1 can be determined. The dependency determined as shown in Fig. 17).

9.1.7 Fit a smooth curve through the pairs of points (σ_1, f_c) . See Fig. 17e). The σ_1 and f_c coordinates should be to the same scale. The dependency of f_c on σ_1 is called the Flow Function (FF) for instantaneous flow.

NOTE 36—The Flow Function usually has a slight curvature convex upwards.

9.1.8 Fit a smooth curve through the points (σ_1, δ) as shown in Fig. 17d. Also, plot in a similar way ϕ_i and ϕ_t as shown in Fig. 17c and ρ_b as shown in Fig. 17a.

NOTE 37—For cohesive materials δ will decrease with increasing σ_1 .

9.2 Evaluation of Time Shear Test Data:

79.2.1 Carry out evaluations separately for each preshear normal stress level. Plot the valid time shear points for each preshear normal stress level in σ, τ -coordinates (Fig. 17 18). Fit a smooth line through the points. This smooth line is called the time yield locus.

79.2.2 Draw a Mohr circle through the origin and tangential to the time yield locus.

NOTE 378—The highest point of intersection of this Mohr circle with the σ -axis is the time unconfined yield strength, f_{cr} . This value, together with

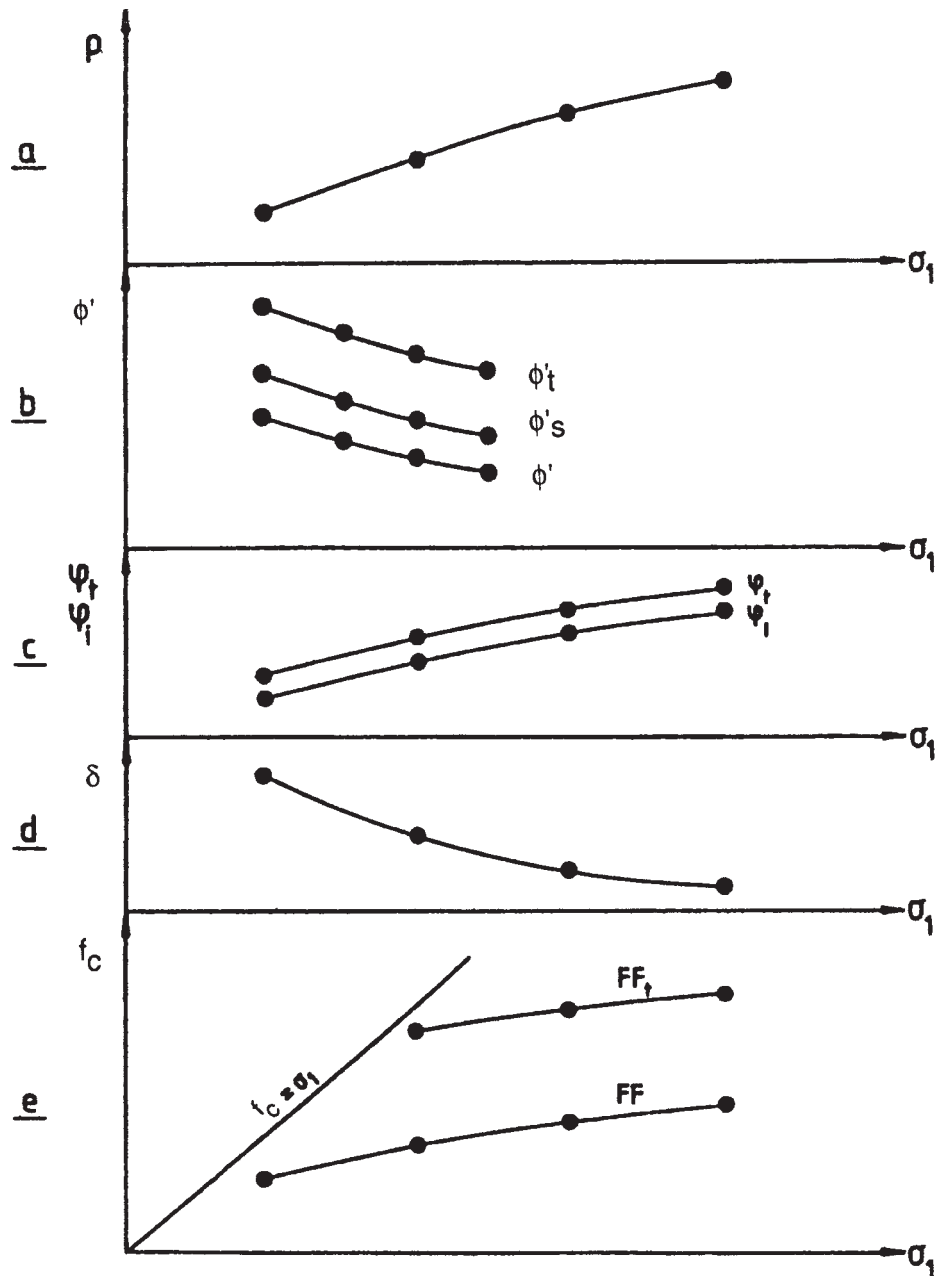

FIG. 197 Powder Properties as a Function of σ_1

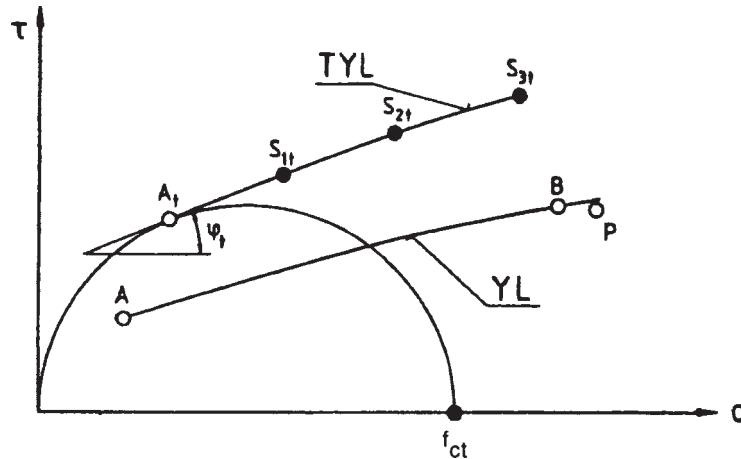

FIG. 178 Time Yield Locus

the major consolidation stress for instantaneous flow, σ_1 , for each selected preshear normal stress gives the values σ_1, f_{ct} that are used in plotting the time flow function, FF_t .

NOTE 389—The angle between the time yield locus and the σ -axis is the time angle of internal friction, ϕ_t for that particular σ_1 (Fig. 178).

79.2.3 Plot the time flow function, FF_t , by fitting a smooth curve or a straight line to the pairs (σ_1, f_{ct}) from each yield locus.

9.3 Evaluation of Wall Friction Test Data:

79.3.1 Plot the points σ_{wi}, τ_{wi} on σ, τ -coordinates and draw a smooth line through the points (Fig. 18 19).

NOTE 3940—This is the wall yield locus (WYL) of the particulate solid on the specific wall material. The plot of the WYL will be a straight line or a curve convex upwards.

79.3.2 If the wall yield locus is a straight line passing through the origin, then $\phi' = \text{constant}$. Otherwise, superimpose a steady state flow Mohr circle associated with a yield locus and a major consolidation stress, σ_1 , on the WYL. Determine the upper point of intersection of the WYL with the steady state flow Mohr circle and draw a straight line through the origin and this point of intersection. The angle that this straight line subtends with the σ -axis is the kinematic angle of wall friction ϕ' at this particular major consolidation stress σ_1 .

79.3.3 By repeating the procedure with consolidating Mohr circles associated with higher preshear normal stresses, obtain the corresponding values (σ_1, ϕ') for each preshear normal stress.

79.3.4 Obtain the static angle of wall friction ϕ'_s by using the σ_{wi}, τ_{wi} values of the peaks. The steady state values give the kinematic angle of wall friction ϕ' .

9.3.5 Plot ϕ' and ϕ'_s as a function of σ_1 , as shown in Fig. 17b.

9.4 Evaluation of wall friction time test data—:

9.4.1 Evaluate wall friction time tests in a similar way to kinematic wall friction tests. Plot the points S_{wt} on σ, τ -coordinates and fit them by a smooth line called the time wall yield locus (TWYL). The analysis gives a time angle of wall friction ϕ'_t for each of the σ_1 values of the superimposed steady state Mohr circles.

9.4.2 Plot ϕ'_t as a function of σ_1 as shown in Fig. 17b.

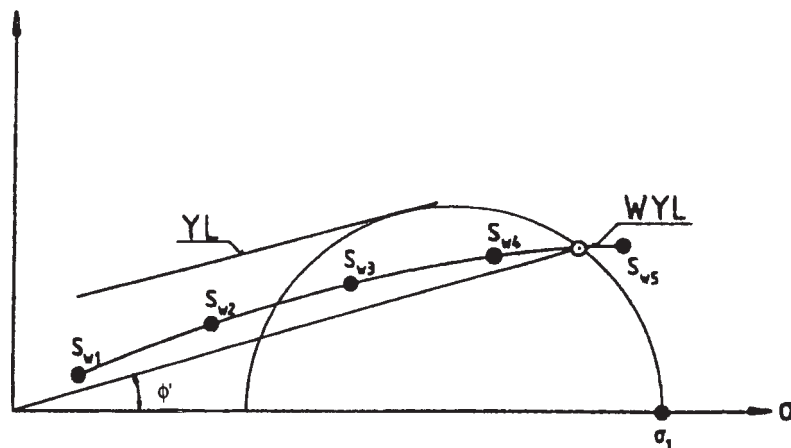

FIG. 189 Wall Yield Locus

810. Report

8.1 Analysis of shear test data for instantaneous flow and after time consolidation and wall friction tests provides

10.1 Provide in plot form the dependence on following properties as a function of σ_1 of the following properties:

8.1.1 Unconfined:

10.1.1 Unconfined yield strength, f_c , that is, flow function, FF_s ;

8.1.1.2 Time unconfined yield strength, f_{ct} , that is, time flow function FF_{t_s} ;

8.1.1.3 Effective angle of friction, δ_s ;

8.1.1.4 Bulk density, ρ_b ;

10.1.5 Angle of internal friction, ϕ_i , for instantaneous flow;

8.1.2 When required by the application, provide in plot form the following additional properties as a function of σ_1 :

10.5.2.1 Angle of internal friction, ϕ_t , after time consolidation.

8.10.6.2 Angle of kinematic wall friction, ϕ' ,

8.10.7.3 Angle of static wall friction, ϕ'_s ;

8.1.8 Angle of time wall friction, ϕ'_{t_s} and

8.1.9 Bulk density, ρ .

8.2 The preceding dependencies are illustrated graphically in Fig. 19. The flow function for instantaneous flow, FF , is obtained by fitting a smooth curve through the pairs of points (σ_1, f_c) . See Fig. 19(e). The σ_1 and f_c coordinates should be to the same scale. The flow function usually has a slight curvature convex upwards.

8.3 In a similar way, the time flow function, FF_t , is obtained by fitting a smooth curve or a straight line to the pairs (σ_1, f_{ct}) .

8.4 The effective angle of friction, δ , is plotted on Fig. 19(d) by fitting a smooth curve through the points (σ_1, δ) . For cohesive materials, δ will increase with decreasing σ_1 .

8.5 In a similar way, the remaining properties can be plotted, ϕ_t and ϕ

10.2.4 Angle of time wall friction, ϕ'_{t_s} on Fig. 19(c) and all the angles of wall friction on Fig. 19(b) and ρ on Fig. 19(a).

911. Precision and Bias

911.1 *Precision*—Data are being evaluated to determine the precision of this test method. In addition, Subcommittee D18.24 is seeking pertinent data from users of this test method.

911.2 *Bias*—There is no accepted reference value for this test method; therefore, bias cannot be determined.

102. Keywords

102.1 bulk solid; cohesive strength; effective angle of friction; effective yield locus; flow function; internal friction angle; Jenike shear cell; kinematic wall friction angle; ~~internal friction angle~~; powder; translational shear tester; unconfined yield strength; wall friction

ANNEXES

(Mandatory Information)

A1. List of Symbols

A	cross-sectional area of cell, m^2
F_v	vertical force, N
F_s	shear force, N
f_c	unconfined yield strength, N/m^2
f_{ct}	time unconfined yield strength, N/m^2
g	acceleration due to gravity ($g = 9.81 \text{ m/s}^2$), m/s^2
m_B	mass of particulate solid in shear ring, kg
m_C	mass of weight carrier on time consolidation bench, kg
m_H	mass of hanger, kg
m_L	mass of shear lid, kg
m_M	total mass of particulate solid in shear cell, kg
m_R	mass of shear ring, kg
m_W	mass of weights, kg
m_{WP}	mass of weights during preshear, kg
m_{WS}	mass of weights during shear, kg
m_{Wt}	mass of weights during time consolidation, kg
m_{Wtw}	mass of weights during twisting, kg
\bar{p}	<u>averaged preshear point</u>
$\frac{S_i}{T}$	<u>prorated and averaged shear point</u>
T	thickness of shear ring, mm

t	consolidation time, h
δ	effective angle of friction, °
ϕ'	kinematic angle of wall friction, °
$\phi's$	static angle of wall friction, °
$\phi't$	time angle of wall friction, °
ϕ_i	angle of internal friction, °
ϕ_i	time angle of internal friction, °
σ	normal stress, N/m ²
σ_p	preshear normal stress, N/m ²
σ_s	shear normal stress or normal stress at shear, N/m ²
σ_{tw}	normal stress during twisting, N/m ²
σ_w	wall normal stress, N/m ²
ρ	bulk density, kg/m ³
ρ_b	bulk density, kg/m ³
τ	shear stress, N/m ²
τ_p	shear stress at preshear, N/m ²
τ_p	average shear stress at preshear, N/m ²
τ_{pt}	<u>shear stress at preshear measured during time consolidation test, N/m²</u>
τ_s	shear stress at failure (shear point), N/m ²
τ_{st}	<u>shear stress at failure (shear point) measured during time consolidation test, N/m²</u>
τ'_s	prorated shear stress at failure, N/m ²
τ'_{st}	<u>prorated time shear stress value at failure N/m²</u>
τ_w	wall shear stress, N/m ²
τ_{wp}	initial shear stress in wall friction time test, N/m ²
τ_{wt}	time wall shear stress, N/m ²

A2. Selection of Sample, Shear Cell, and Test Weights

A2.1 Sample Selection:

A2.1.1 For meaningful results, select a representative sample of the particulate solid with respect to moisture content, particle size distribution, and temperature. For the tests approximately 10 L of the material should be available, and a fresh material should be used for each individual test specimen. If such a quantity is not available, use a smaller shear cell. If as a last resort shear tests have to be repeated on the same specimen, then before each test, the material should be well loosened.

A2.1.2 The flowability of a particulate solid is usually significantly dependent on its moisture content which at equilibrium depends on the ambient humidity. In view of the significant influence of moisture, the amount anticipated during actual storage and flow should be closely reproduced in the test specimen, for example, by equilibrating it to this humidity. To prevent moisture evaporation or adsorption, it is advisable to keep the test material in an airtight container, replacing the cover of the container between tests. To prevent inhomogeneities in water content, stir the material in the container regularly and, during the test, handle the specimen and the shear cells rapidly. Upon completion of time tests, recheck the moisture in the solid from the shear cells. Ideally, measurements should be made in an air-conditioned room with controlled humidity.

A2.1.3 The effect of particle size distribution is not as perplexing as it might appear. During the flow of a mass of mixed particle sizes, the large particles move bodily while the solid shears primarily across the fines. The coarse particles contribute little to the cohesion of the mass; therefore, the flowability of the mass depends on the properties of the fines. The standard size Jenike shear tester cell is suitable for testing particulate solids with particle sizes of up to 5 % of the shear cell diameter. Coarser particles should be removed by hand. When removing the larger particles, it is necessary, in so far as possible, to retain the structure of the solid and the moisture content of the fines. If there is danger that by sieving the structure of the solid will be altered, spread the material gently on a tray and remove the larger particles by hand. Do not screen fibrous solids, whose strength is due to the interlocking of the fibers. Such solids are on the borderline of applicability of this test method. Take great care to ensure that the particles do not segregate between sample withdrawal and testing (for example, during transport coarse particles can segregate towards the surface of a material in a container and, if this surface material is taken for shear testing, it will have a lower shear strength). If tests are repeated on the same specimen, take care not to lose fines, for example, by ventilation.

A2.1.4 The effect of temperature on the flowability of solids may be significant. Tests of such solids require either a shear tester and a consolidating bench which permit the adjustment and control of temperature, or a temperature-controlled room.

A2.1.5 The coupon of wall material should be flat, 120-mm square or larger and representative of the material on which the particulate solid will slide. Take care in that some types of wall materials have directional properties (for example, rolled steels). In such cases, orient the coupon of wall material in the same direction as in the actual equipment (hopper).

A2.1.6 The effect of vibration on the shear strength of particulate solids is not treated in this test method. However, since vibrations influence the shear strength of particulate solids to a considerable extent, take care that during measurements the shear cell is completely free of any vibration either from the force measuring stem driving mechanism, or from the test room.

A2.2 Shear Cell Selection:

A2.2.1 When measuring the shear strength of particulate solids having bulk densities in the range from 300 to approximately 2400 kg/m³, use a standard size shear cell. For particulate solids with bulk densities below 300 kg/m³, or when performing shear tests at very low normal stress levels, a light metal shear cell is recommended.

A2.2.2 At higher preshear normal stress levels and with particulate solids having bulk densities above 2400 kg/m³, a shear cell of smaller diameter may be used if the available force transducer has insufficient range.

A2.3 Equivalence Between Weights and Stresses:

A2.3.1 The results of shear tests are expressed in terms of stresses, that is, by the shear stress and the normal stress in the shear plane (plane between shear ring and base). However, cells are loaded by weights and therefore it is necessary to equate these weights to the corresponding stresses. This equivalence is given by the following equations:

$$\sigma = \frac{F_v}{A} = \frac{(m_B + m_R + m_L + m_W) g}{A} \quad (\text{A2.1})$$

$$\sigma = \frac{F_v}{A} = \frac{(m_B + m_R + m_L + m_H + m_W) g}{A} \quad (\text{A2.1})$$

where

- σ = normal stress, Pa,
- m_B = mass of particulate solid in the shear ring, kg,
- m_R = mass of the ring, kg,
- m_L = mass of the shear lid, kg,
- m_H = mass of the weight hanger, kg,
- m_W = mass of the weights, kg,
- g = acceleration due to gravity (9.81 m/s²), and
- F_v = vertical force, N,
- A = cross-sectional area of the cell, m².

$$\tau = \frac{F_s}{A} \quad (\text{A2.2})$$

where

- τ = shear stress, Pa and
- F_s = shear force, N.

If weights are stacked directly on the lid when running shear tests without a hanger, the term m_H is omitted from Eq A2.1. Read the shear force, F_s , from the calibrated recorder.

A2.3.2 In this test method, the loading of shear cells by weights is expressed in the form of the normal stress in the shear plane. The operator of the shear cell, therefore, must derive from Eq A2.1 the corresponding weight of mass m_{W2} which he places on the hanger. ~~Masses Selection of the masses of weights corresponding to preshear normal stresses may be rounded up to 1 kg if above 4 kg and to 0.5 kg if below 4 kg.~~ Selection of the masses of weights corresponding to shear normal stresses may be rounded up to kilograms if above 6 kg, to 0.5 kg if between 2 and 6 kg, and to 0.1 kg if below 2 kg. This rounding up is used only for the selection of weights. From the total of the masses in question, calculate the normal stress to an accuracy of 10 Pa.

A2.3.3 In order to attain the required degree of accuracy, measure all weighed components to a precision of 1 g. Although weights are normally well within the required tolerance, it is advisable to check them on purchase. A recently calibrated balance is suitable for this. When plotting dependencies of τ on σ , it is necessary to know the mass of powder above the plane of shear, which in Eq A2.1 is approximated by the amount of material in the ring, m_B . To measure this, determine the total mass of particulate solid in the shear cell, m_M , by weighing the base, shear ring, shear lid, and material in the cell to the required 1-g precision after the shear test and from the known volumes of the ring and base, calculate the corresponding mass of material above the shear plane, m_B . This assumes that the contents of the cell are homogeneous with respect to density. For cohesive materials, the amount of material above the shear plane may be determined directly by weighing the shear ring and the powder in it after shear. As the actual shear plane does not usually coincide with the plane between the ring and base, direct measurement will probably give results that are different from those calculated from m_M and the volumes of the parts of the cell. For the same reason, directly determined values of m_B are likely to vary more from test to test.

A2.3.4 These discrepancies are likely to be insignificant for all tests, except for those at the lowest normal loads. For more free-flowing materials which are likely to fall out of the ring as it is lifted, the direct method cannot be used and the volumetric method is necessary. Particulate solids bulk densities, γ , ρ_b , should be calculated from m_M rather than direct weight of material in the ring as the differences in volume of solids from test to test due to differences in the position of the plane of shear will be much more significant with respect to the mass of particulate solids alone compared with the sum of the masses in Eq A2.1. As the base has an irregular inside shape, its volume is best determined by weighing it empty and then again when filled with water exactly to the top. Determine the volume of the ring from its dimensions.

A2.3.5 If the shear tester is used with several bases, rings, and shear lids, it is advisable to mark the parts so that the weights of those used in a particular test may be readily identified.

A3. Optimization Procedure

A3.1 Trial tests which are performed with the aim of obtaining a critically consolidated specimen are called optimization. Optimization has to be repeated for each preshear normal stress level.

A3.2 Inspect the shear force-time record, which is equivalent to a shear stress-shear strain record, and depending upon the degree of compaction of the particulate solid produced by the applied weight of mass $m_{w_r w_p}$, three general types of shear force-strain curves may be obtained (shown by full lines in Fig. A3.1).

A3.3 If for the material under test the degree of compaction is insufficient, the shear force will increase continually during shear (Fig. A3.1, Curve 3). Such a specimen is said to be underconsolidated, and the bulk density in the shear zone increases during shear. If the degree of compaction is excessive, the shear force rises initially, passes through a maximum and then decreases (Curve 1). Such a specimen is said to be overconsolidated, and the bulk density in the shear zone is thought to decrease after passing through a maximum.

A3.4 There is, however, a degree of compaction when the shear force rises initially, but having reached a certain value remains constant during the remainder of shear (Curve 2). Such a specimen is said to be critically consolidated, and that part of the test when the shear force is constant is called steady state flow. In such a specimen, the bulk density and shear stress in the shear zone remain constant during shear.

A3.5 It has been shown that for a given particulate solid at a given normal stress acting in the shear zone, the shear stress and the bulk density during steady state flow have unique values.

A3.6 Thus, it can be seen that for a given m_{w_p} , the plot of the shear force versus strain strongly depends on the original bulk density of the particulate solid in the cell which in turn is a result of the degree of compaction of the material during preparation of the specimen for shear testing.

A3.7 The shear test, therefore, consists of two parts. The first of these is the preparation of a critically consolidated specimen and the attainment of steady state flow in the shear cell with a definite bulk density in the shear zone. This bulk density is defined by the values of the normal and shear stresses for steady state flow. In the second part of the test, an actual shear stress measurement is performed in which, for a selected value of the normal force, $m_{w_s} < m_{w_p}$, the necessary shear force for the material to yield is determined.

A3.8 To simplify the situation, it is possible to imagine that if the shear cell was capable of shear through an infinite distance (for example, in an annular shear cell) then steady state flow could be attained simply by allowing the specimen to shear through a long enough distance. Underconsolidated samples would follow the full and then the dashed line marked 3 in Fig. A3.1. Overconsolidated samples would follow the full and then the dashed Curve 1 in Fig. A3.1. In both cases, the shear force would eventually attain the level corresponding to a critically consolidated specimen, as in Curve 2. (In reality, this is not necessarily the

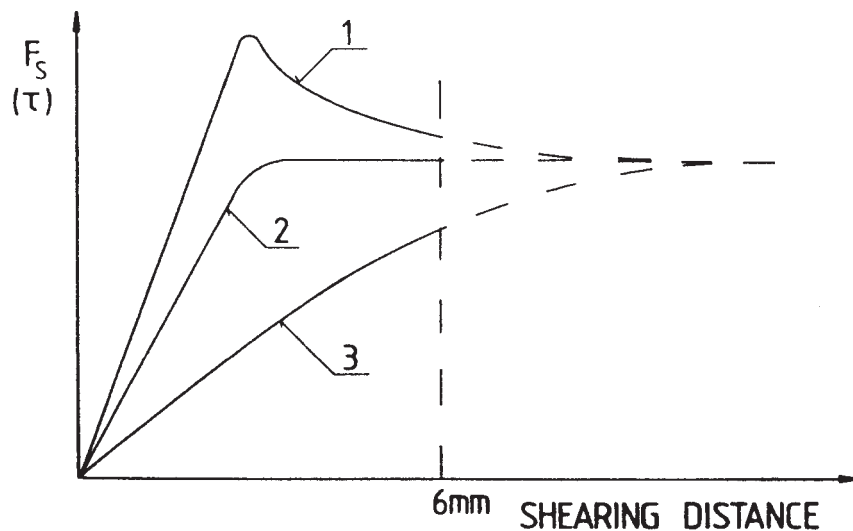

FIG. A3.1 Stress-Strain Curves for Over, Critically and Under Consolidated Samples

case since prolonged shear can by the attrition or orientation of particles in the shear zone lead to the formation of a single shear plane whose properties may be different from those of a shear zone.)

A3.9 The Jenike shear cell, however, is limited to a shear distance of approximately 6 mm, represented by the dashed vertical line in Fig. A3.1. Therefore steady state flow must be attained within a shear distance of up to 4 to 5 mm leaving the remaining distance for the actual shear test. For the specimen to attain steady state flow in such a short shear distance, the specimen must be close to critical consolidation prior to shear. The technique for obtaining steady state flow during a short shear distance, called consolidation, was developed by Jenike and consists of twisting and preshear.

A3.10 If the specimen is underconsolidated (Fig. A3.1, Curve 3), then prepare additional specimens in which the number of twists is increased stepwise to a maximum of 50. For each number of twists selected, perform a shear test and inspect the stress-strain record until critical consolidation is found to have occurred. If after 50 twists the specimen is still underconsolidated, increase the consolidating normal stress applied during twisting by approximately $0.5 \sigma_p$ increments. Shear specimens again after being twisted by up to 50 times. When a consolidating normal stress is found which produces an overconsolidated specimen (Curve 1), make a finer adjustment of the consolidating normal stress σ_{tw} and of the number of twists to obtain a critically consolidated specimen. Alternative techniques are sometimes required in order to obtain this desired result.

A3.11 If the specimen after the first test is overconsolidated, decrease the number of twists during twisting stepwise to a minimum of about 5 and, if the material is still found to be overconsolidated, reduce the consolidating normal stress. Again make a final adjustment of σ_{tw} and number of twists to obtain a critically consolidated specimen.

A3.12 The output from the stress-strain recorder need not be a smooth curve but may contain various irregularities due to the formation of shear planes. Some experience is necessary in interpreting the stress-strain records to identify the conditions for critical consolidation. It is helpful to obtain a distinctly underconsolidated specimen, a distinctly overconsolidated specimen, and then an intermediate condition for critical consolidation, tending toward the underconsolidated, never the overconsolidated state. With some materials it is very difficult to obtain overconsolidated samples; therefore, it is necessary to judge the stress-strain curves from only underconsolidated and critically consolidated samples.

A3.13 The steady state shear stress should be attained after a shear distance not greater than three fourths of the total shear distance permitted by the amount of overlap between the rings in order to allow for further shear during the shear test itself.

A3.14 If the particulate solid specimen is prone to attrition, σ_{tw} should not be increased beyond $2\sigma_p$. If under these conditions the specimen is still underconsolidated, perform twisting with $\sigma_{tw} = 2\sigma_p$ and start preshear with a stack of weights on the hanger corresponding to a total normal force of $2\sigma_p$. As the shear force rises, remove weights one at a time, keeping pace with the rise of the shear force until only weights corresponding to σ_p remain on the hanger. At no time during preshear, however, should the recorded shear stress exceed that finally determined for steady state flow.

A3.15 When testing some coarse materials, the front of the shear ring may rise somewhat (over 1 mm) during preshear or shear. In such cases, it is possible to manually press the front of the ring gently down to maintain alignment of the shear ring and base.

References

- (1) Standard Shear Testing Technique for Particulate Solids using the Jenike Shear Cell, a report of the EFCE Working Party on the Mechanics of Particulate Solids. Copyright is held by The Institution of Chemical Engineers and the European Federation of Chemical Engineering, Rugby, England, 1989.
- (2) Jenike, A. W., *Storage and Flow of Solids*, Bul. 123, Utah Engineering Experiment Station, 1964 (Rev. 1980).
- (3) Peschl, I.A.S.Z., "Measurement and Evaluation of Mechanical Properties of Powders," *Powder Handling and Processing*, Vol 1, No. 2, June 1989, pp. 135–142.

SUMMARY OF CHANGES

- (1) Numerous minor typos have been corrected.
- (2) Many notes have been changed to make the instructions mandatory.
- (3) In Section 3, Terminology, definitions have been added for adhesion test, cohesive strength, critical state, overconsolidated specimen and underconsolidated specimen.
- (4) A new Section 4, Summary of Test Method, has been added.
- (5) Notes 8, 17, and 18 have been modified to reflect other possible test interpretations.
- (6) Section 8.2.5.2 describing prorating of time shear points is new.
- (7) The procedure for rubbing wall coupons in 8.3.3.7 is new.

ASTM International takes no position respecting the validity of any patent rights asserted in connection with any item mentioned in this standard. Users of this standard are expressly advised that determination of the validity of any such patent rights, and the risk of infringement of such rights, are entirely their own responsibility.

This standard is subject to revision at any time by the responsible technical committee and must be reviewed every five years and if not revised, either reapproved or withdrawn. Your comments are invited either for revision of this standard or for additional standards and should be addressed to ASTM International Headquarters. Your comments will receive careful consideration at a meeting of the responsible technical committee, which you may attend. If you feel that your comments have not received a fair hearing you should make your views known to the ASTM Committee on Standards, at the address shown below.

This standard is copyrighted by ASTM International, 100 Barr Harbor Drive, PO Box C700, West Conshohocken, PA 19428-2959, United States. Individual reprints (single or multiple copies) of this standard may be obtained by contacting ASTM at the above address or at 610-832-9585 (phone), 610-832-9555 (fax), or service@astm.org (e-mail); or through the ASTM website (www.astm.org).