



Standard Methods of Testing Structural Insulating Roof Deck¹

This standard is issued under the fixed designation D 2164; the number immediately following the designation indicates the year of original adoption or, in the case of revision, the year of last revision. A number in parentheses indicates the year of last reapproval. A superscript epsilon (ε) indicates an editorial change since the last revision or reapproval.

INTRODUCTION

The test methods presented herein relating to structural properties were developed to measure the resistance of insulating roof deck to forces expected or possible when the product is used as roof decking, usually in exposed beam construction.

Insulating roof deck is a laminated composite of interior and weather-resistant grades of insulating board where the interior, factory-finished board provides the finished ceiling and the glued-laminated composite provides the structural deck, the base for built-up or other roofing and the thermal insulation. Vapor barriers are provided where use conditions require. While these test methods were developed specifically for measuring the deflection and strength characteristics of roof deck of insulating board, the concept is based on loads and forces applicable to any structural deck. Results of test are presented in terms usually used by architects and structural engineers.

Presented here are methods of test only. The criteria to be applied to the results of test are a matter that must be considered when these methods are used to determine limiting values for a procurement specification or for any purpose. A case in point is the accelerated aging exposure detailed in Sections 25 and 29. That exposure cycling was developed many years ago to obtain a measure of the resistance of a material to deterioration under exterior exposure conditions. It was selected for inclusion in this compilation of structural test methods for insulating roof deck, fully realizing that roof deck usually would not be subjected to a combination of exposures as severe as for materials exposed directly to the elements. It was the considered opinion, however, that the procedure would ensure adequate performance of insulating roof deck in use.

The methods presented herein are only for structural properties. For physical properties such as thermal conductivity and vapor permeability, which are important to the use of these materials, the appropriate ASTM methods for determining those properties of any engineering material are referenced and should be used. Instructions are included in these methods for specimen preparation and presentation of the results.

1. Scope

1.1 These methods cover determination of the following properties of structural insulating roof deck. In all structural tests the specimens are loaded as beams with the finished (ceiling) face in tension.

	Sections
Equivalent Uniform Load	8-12
Concentrated Load	13-16
Sustained Uniform Load (Sag)	18-20
Impact Load	21-24
Resistance to Cyclic Exposure	25-29
Thermal Conductance (Test Method C 177)	30-32

Water Vapor Permeance (Test Method C 355)

33-37

1.2 The values stated in inch-pound units are to be regarded as the standard. The metric equivalents of inch-pound units may be approximate.

1.3 *This standard does not purport to address all of the safety concerns, if any, associated with its use. It is the responsibility of the user of this standard to establish appropriate safety and health practices and determine the applicability of regulatory limitations prior to use.*

2. Referenced Documents

2.1 *ASTM Standards:*

¹ These methods are under the jurisdiction of ASTM Committee D07 on Wood and are the direct responsibility of Subcommittee D07.03 on Panel Products.

Current edition approved Dec. 30, 1983. Published February 1984. Originally published as D 2164 – 63 T. Last previous edition D 2164 – 65 (1977).

C 177 Test Method for Steady-State Heat Flux Measurements and Thermal Transmission Properties by Means of the Guarded Hot Plate Apparatus²

C 355 Test Methods for Water Vapor Transmission of Thick Materials³

D 1037 Test Methods for Evaluating Properties of Wood-Base Fiber and Particle Panel Materials⁴

E 72 Methods for Conducting Strength Tests of Panels for Building Construction⁵

3. Significance and Use

3.1 Insulating roof panels need to comply with bending strength and deflection criteria found in applicable building codes. This standard establishes procedures for determining the load-carrying properties of such panels under uniform, concentrated, and impact load; and for evaluating durabilities.

3.2 The test procedures outlined consider the effects of long- and short-term load applications on roof deck samples. The procedures outlined parallel similar ASTM procedures for traditional decking systems. Test results are appropriate for the determination of conformance to establish criteria. This standard does not establish or identify performance requirements.

4. Descriptions of Terms Specific to This Standard

4.1 *structural insulating roof deck*—Refers to a structural insulating board product designed for use in open-beam ceiling roof construction. It is designed for applications to flat, pitched, or mono-sloped roofs for providing (1) the structural roof deck, (2) efficient insulation, and (3) the interior ceiling finish. The underside of the deck, which remains exposed to the room, is usually factory-finished and, in addition, may be obtained with varying degrees of acoustical treatment. The structural insulating roof deck shall be composed of multiple layers of structural insulating board, either plain or asphalt-impregnated, laminated together with a water-resistant adhesive. The composite will normally consist of approximately ½ in. (12.7 mm) of factory-finished interior-grade insulating board which is laminated to several layers of structural-grade insulating board, giving a product of nominal thicknesses of 1½, 2, or 3 in. (38, 51, 76 mm), a width of 2 ft (61 cm) and a length 8 ft (244 cm) with the long edges fabricated to form an interlocking joint when applied. Short edges are normally either interlocking or square. A vapor barrier may be present in the product, and provision may be made for sealing of joints against vapor passage under cold-weather use.

4.2 *slab*—refers to the material, normally in commercial sizes, as received.

4.3 *sample*—refers to the collection of slabs selected in accordance with Section 5.

4.4 *specimen*—refers to the test piece cut from a slab, unless otherwise specified in the test method.

5. Sampling

5.1 Slabs shall be selected at random so as to give a fair representation of the entire shipment. The number of slabs to be selected shall be as follows:

5.1.1 *Less-than-Carload Shipments*—Five-tenths percent of the number of slabs in shipment, but not less than three nor more than five slabs of any shipment.

5.1.2 *Carload Shipments*—Five slabs.

5.1.3 *More than One Car or Carrier Load*—Five slabs from each car or carrier load.

6. Test Specimens

6.1 For the strength tests, namely, equivalent uniform load, concentrated load, sustained uniform load (sag), impact load, and durability, three test specimens shall be cut from each five slab sample (two test specimens from each three slab sample) for each type of test. These specimens shall be 10 in. (254 mm) wide by 4 in. (101.6 mm) longer (Note 1) than the distance between the supports of the testing device and shall be cut with their long dimensions parallel to the long dimension of the slab. The width, length, and thickness of each specimen shall be measured to an accuracy of not less than $\pm 0.3\%$.

NOTE 1—For the 1½-in. (38-mm) nominal thickness material the total length of specimen shall be 28 in. (71 cm). For the 2-in. (51-mm) nominal thickness material the total length of specimen shall be 40 in. The total length for 3-in. (76-mm) nominal thickness material shall be 48 in. (122 cm) and the span shall be shortened from 16 times the thickness to 44 in. (111.7 cm) to permit two specimens to be cut from the 8-ft (244-cm) length of the material as manufactured.

6.2 For the thermal conductance test and the vapor permeance test, specimens shall be as prescribed in Test Method C 177, and Test Methods C 355, respectively. For each sample as defined in 4.3 there shall be two thermal conductance tests for each five-slab sample (one for a three-slab sample) and three vapor permeance tests for each five-slab sample (two for a three-slab sample).

7. Conditioning

7.1 *Specimens Tested for Strength*—All strength tests should be made on test specimens conditioned until practical equilibrium is obtained, not less than 24 h at a relative humidity of $50 \pm 2\%$ and a temperature of $70 \pm 5^\circ\text{F}$ ($21 \pm 3^\circ\text{C}$). When there is any digression from this conditioning prior to test, specimens shall not be changing in moisture at the time of test, and moisture content of each specimen based on oven-dry weight shall be determined and reported as described in Test Methods D 1037.

7.2 Conditions for thermal conductance and vapor permeance shall be as described in Test Method C 177 and the Desiccant Method of Test Methods C 355, respectively.

EQUIVALENT UNIFORM LOAD

8. Scope

8.1 This method covers measurement of the deflection and strength characteristics of the roof deck when loaded as a beam as it will normally be loaded in use. Spans required for the different thicknesses of deck are those usually recommended in actual construction.

² Annual Book of ASTM Standards, Vol 04.06.

³ Discontinued, see 1981 Annual Book of ASTM Standards, Part 18.

⁴ Annual Book of ASTM Standards, Vol 04.10.

⁵ Annual Book of ASTM Standards, Vol 04.07.

9. Apparatus

9.1 *Testing Machine*—Any standard mechanical or hydraulic testing machine capable of applying and measuring the required load within an accuracy of ±2 %.

9.2 *Other Equipment*—Loading blocks, supports, and dial gage as prescribed in Section 10 and shown in Fig. 1.

10. Procedure

10.1 *Span and Supports*—The span for each test shall be 24, 32, or 44 in. (61, 81, 112 cm) for the nominal 1½, 2, and 3-in. (38, 51, 76-mm) thicknesses, respectively. The supports, at least 10 in. (254 mm) long, shall be rounded to a radius of 1½ times the nominal thickness being tested. The radius used shall not vary by more than ± 50 % from that specified. The supports shall be straight and shall maintain full contact with the specimen throughout the test.

10.2 *Loading*—Load the specimens through two rounded bearing blocks, at least 10 in. long, at the quarter-points of the span. The bearing blocks shall be rounded to a radius of 1½ times the nominal thickness being tested, and the radius shall not vary by more than ±50 %.

10.3 *Speed of Testing*—Apply the load continuously throughout the test at a uniform rate of motion of the crosshead of the testing machine of 0.30, 0.45, and 0.60 in. (7.6, 11, and 15 mm)/min for the 1½, 2, and 3-in. thicknesses, respectively. The speed used shall not vary by more than ±50 % from that specified.

10.4 *Load-Deflection Curves*—Obtain load-deflection curves to maximum load for all tests. Obtain the deflection of the center of the lower surface of the specimen by means of a suitable indicating dial gage. Read the deflection to the nearest 0.01 in. (0.25 mm).

11. Calculation

11.1 *Modulus of Rupture*—Calculate the modulus of rupture for each specimen as follows:

$$R = (3 PL)/(4bd^2) \tag{1}$$

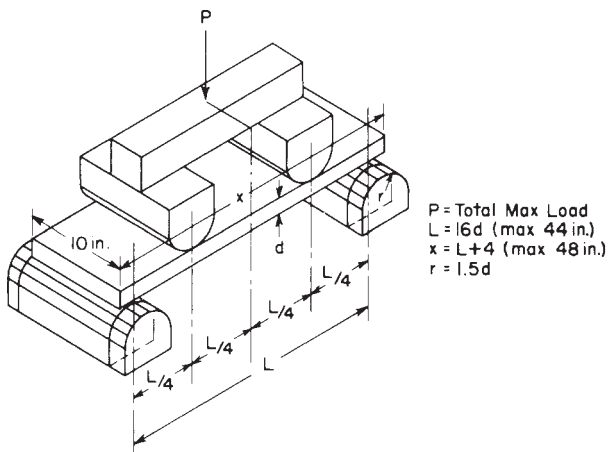

Metric Equivalents

in.	10	44	48
cm	25.4	111.7	122

FIG. 1 Apparatus for Equivalent Uniform Load

where:

- R = modulus of rupture, psi (MPa),
- P = total maximum load, lbf (kN).
- L = span, in. (mm),
- b = width of specimen, in. (mm), and
- d = depth or thickness of specimen, in. (mm) (average of six measurements; at each edge and center of specimen along quarter point)

11.2 *Modulus of Elasticity*—Calculate the modulus of elasticity for each specimen as follows:

$$E = (11 P_1 L^3)/(64 bd^3 y) \tag{2}$$

where:

- L , b , and d are previously identified,
- E = modulus of elasticity, psi (MPa),
- P_1 = some load lbf (kN) on the straight-line position of the load-deflection curve, and
- y = deflection for load P_1 , in. (mm)

11.3 *Equivalent Pounds-force per Square Foot of Uniform Live Load*—Calculate the equivalent uniform load for each specimen as follows:

$$W_{LL} = (192 Rd^2)/L2 \tag{3}$$

where:

- R , d , and L are previously identified, and
- W_{LL} = equivalent uniform load at failure, lbf/ft²

11.4 *Deflection-Span Ratio*—Calculate the deflection-span ratio for a uniform applied live load of 30 lbf/ft² for each specimen as follows:

$$\text{Deflection-span ratio} = (25 L^3)/(768 Ed^3) \tag{4}$$

where the terms are as previously identified. The deflection-span ratio should be expressed in the form 1/x.

12. Report

12.1 The report shall include the individual values of modulus of rupture (R), modulus of elasticity (E), equivalent pounds-force per square foot of live load (W_{LL}) at failure, and deflection-span ratio calculated as outlined in Section 11. For the equivalent pounds-force per square foot of live load and the deflection-span ratio, the over-all property values for a given thickness shall be taken as the averages for all the specimens of that thickness tested. The type of failure of each specimen shall be described.

CONCENTRATED LOAD

13. Scope

13.1 This method covers measurement of the minimum resistance of the decking to a concentrated force. Loading is at midspan along the unsupported edge. The decking will be able to sustain loads of greater magnitude at any other location than the one obtained from this test. Spans required are the same as for the equivalent uniform load test.

14. Apparatus

14.1 *Testing Machine*—The testing machine described in 9.1 is suitable.

14.2 *Other Equipment*—Loading blocks, supports, and bearing plate shall be as described in Section 15 and shown diagrammatically in Fig. 2.

15. Procedure

15.1 *Span and Supports*—Span and supports shall be the same as required in 10.1 with the additional requirement that the specimen shall be restrained at each support with a similar rounded block to avoid lifting of the specimen during test. Fig. 3 shows a suitable way of providing the necessary restraint.

15.2 *Loading*—Load the specimen through a 4 by 4-in. (101.6 by 101.6-mm) square metal bearing plate of which the edges on the contact face shall be rounded to a radius of 1/2 in. (6 mm). The bearing plate shall have a spherical seat at its center and shall be loaded by means of a 1-in. (25.4-mm) diameter steel rod whose end is either pointed or rounded to a radius of 1/2 in. (12.7 mm). One edge of the bearing plate shall be flush with the edge of the specimen midway between the supports.

15.3 *Speed of Testing*—Apply the load continuously throughout the test at a uniform rate of motion of the crosshead of the testing machine using the same rates 0.30, 0.45, and 0.60 in. (7.6, 11, and 15 mm)/min for the different thicknesses as in 10.3.

16. Report

16.1 Report the individual concentrated loads as the maximum loads reached in pounds-force (kilonewtons) for the separate specimens. The concentrated load strength in pounds-force for each thickness tested shall be reported as the average for all specimens of that thickness. A description of the type of failure shall be given.

SUSTAINED UNIFORM LOAD (SAG)

17. Scope

17.1 This method covers measurement of the resistance of the roof deck to creep under continued loading. Long contin-

ued live load is simulated by the application of weights of 2.4 times design applied load of 30 lbf/ft² to the decking supported as in service. The measurement of increased deflection after 48 h of loading and the residual remaining after the load is removed is the measure of sag characteristics of the deck.

18. Apparatus

18.1 *Span and Supports*—Supports shall be rounded loading blocks as required for the other tests. They shall be mounted on a suitable base as shown in Fig. 4. Two scales shall be provided for each specimen being loaded at one time so that deflections at the center of the span may be obtained for each side of the specimen at midheight by a fine wire as shown.

NOTE 2—The use of two wires placed about 1/2 in. (12.7 mm) apart on each side of the specimen has proved useful in eliminating parallax when reading deflections. These wires may be attached to nails or pins driven into the sides of the specimen at mid-height over each support. When this is done, the operator sights in a plane produced by each pair of wires for each deflection reading.

18.2 *Weights* for loading shall each be 15 lb. A sufficient number of weights shall be provided so that one such weight can be placed in each 5 by 6-in. (127 by 152-mm) square on the surface of the decking as shown in Fig. 5.

19. Procedure

19.1 *Span and Supports*—Spans for the different thicknesses of decking shall be the same as required for the equivalent uniform load test (10.1).

19.2 *Loading and Deflection*—Load the specimens with weights totaling 60 lb/lineal ft (72 lb/ft²). The procedure for each test shall be as follows:

19.2.1 Place the specimen on the supports; attach deflection scales at the midspan along each side. Attach the end of the wires at the midheight of the specimen at the supports. Record the initial readings.

19.2.2 Load the specimen by placing 15-lb (6.7 kg) weights at the center of each 5 by 6-in. (127 by 152-mm) square. Immediately on completion of loading, read and record the deflections.

19.2.3 After 48-h duration of loading, reread and record the deflections. Remove the weights from the specimen.

19.2.4 One hour after removal of the weights read and record the final deflection.

20. Report

20.1 Report the average of the two center deflections for each edge in inches for each period for each specimen. The residual deflection or sag for each thickness tested shall be the average deflection in inches taken 1 h after load removal for all specimens of that thickness.

IMPACT LOAD

21. Scope

21.1 This method covers determination of impact resistance for specimens loaded as beams and subjected to impacts of a 10-lb (4.5-kg) sandbag from increasing heights to failure.

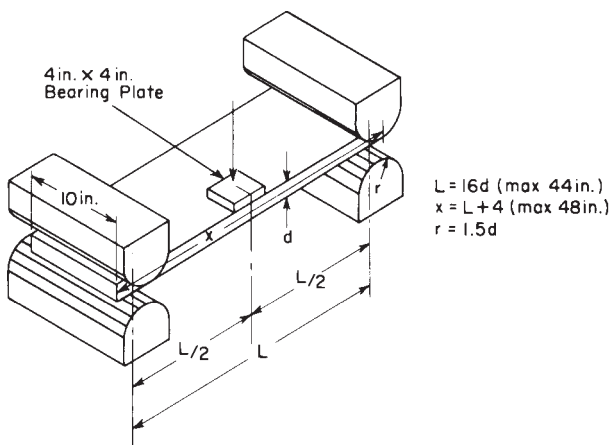

Metric Equivalents

in.	4	10	44	48
cm	10	25	111.7	122

FIG. 2 Apparatus for Concentrated Load Test, Schematic

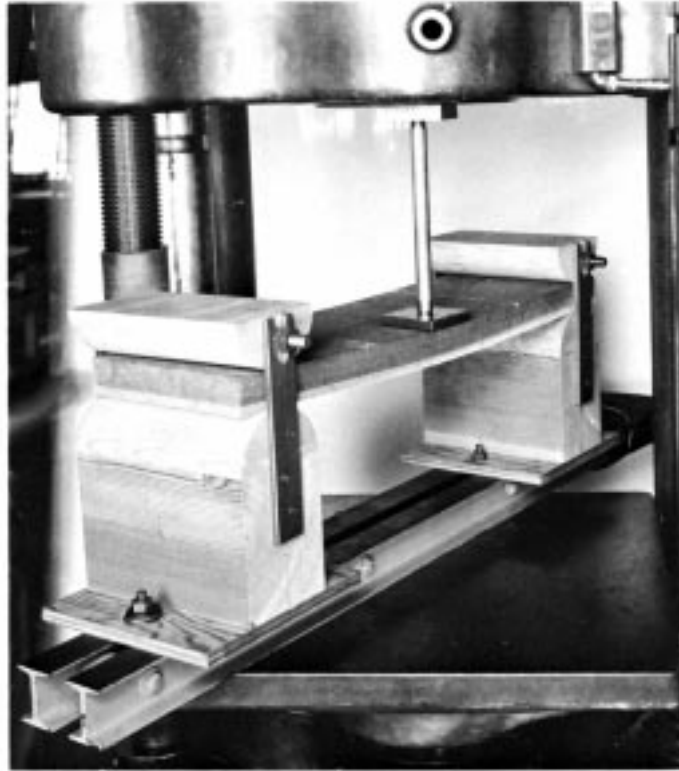

FIG. 3 Apparatus for Concentrated Load Test, Pictorial

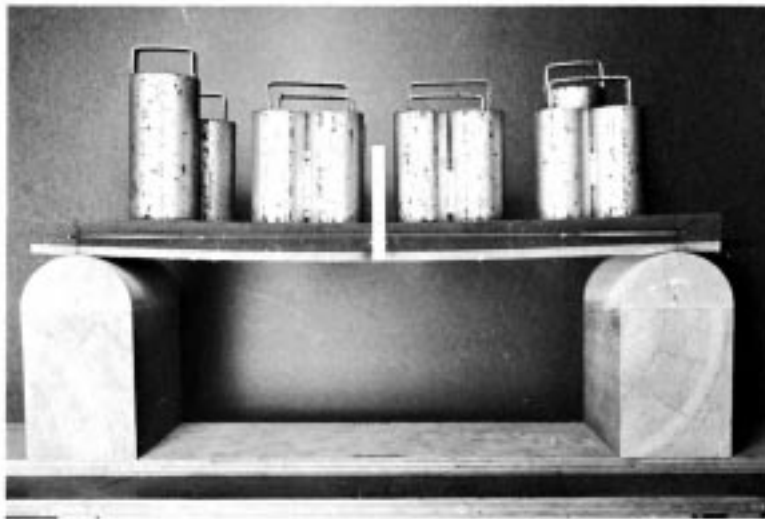

FIG. 4 Apparatus for Sustained Uniform Load Test, Pictorial

22. Apparatus

22.1 *Span and Supports*—The supports and restraining equipment for preventing the specimen from “bouncing” off the supports when it is impacted shall be as required for the concentrated load tests (15.1) and shown in Fig. 6 and Fig. 7. Spans for the different thicknesses of decking shall be the same as for the other tests, 16 times the nominal thickness except for 3-in. (76-mm)-thick material which shall be 44 in. (111.7 cm). The entire support assembly shall be set on a solid surface.

22.2 *Sandbag*—The leather-covered sandbag shall be constructed as described in Methods E 72, except that it shall weigh 10 lb (4.5 kg), its base shall be 5 in. (127 mm) in diameter, and its height shall be approximately 12 in. (30 cm)

23. Procedure

23.1 *Loading*—Apply an impact load to the center of the specimen by dropping the 10-lb (4.5-kg) sandbag. Hoist the bag by a suitable pulley arrangement and release when the bag

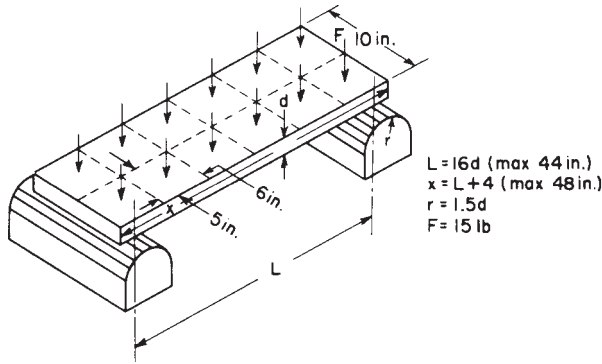

Metric Equivalents

in.	5	6	10	44	48
cm	12.7	15	25	111.7	122

FIG. 5 Apparatus for Sustained Uniform Load Test, Schematic



FIG. 6 Apparatus for Impact Load Test, Pictorial

is at the desired height. Drop the bag first from a height of 1 ft (30 cm) and continue dropping from the heights of 6-in. (152-mm) increments until breakthrough of the specimen occurs.

23.2 *Failure*—Height of drop at failure is defined as the one producing a tension failure along the bottom surface of the specimen.

24. Report

24.1 Report the maximum height of drop in feet for each specimen. Report the impact load strength in foot-pounds by multiplying the height of drop in feet times the weight of the sandbag (10 lb) (4.5 kg) for the thickness tested. It shall be the average for all the specimens of that thickness.

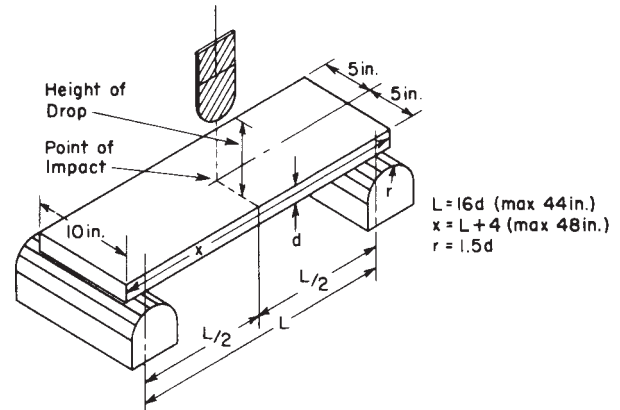

Metric Equivalents

in.	5	10	44	48
cm	12.7	25	111.7	122

FIG. 7 Apparatus for Impact Load Test, Schematic

RESISTANCE TO CYCLIC EXPOSURE

25. Scope

25.1 This method covers the evaluation of resistance to cyclic exposure. The strength of specimens after six complete cycles of accelerated aging is compared to that of specimens evaluated in the “as received” condition (under the requirements of Sections 8-12, inclusive). The loss in strength after aging is assumed to be the measure of loss in strength after many years of service under extreme weathering conditions.

NOTE 3—This evaluation procedure is intended to evaluate the deterioration resistance of the component boards and the adhesive bond that laminates those components. Temperature conditions at the extremes of cycling are in excess of those possible at the line where vapor barriers are installed. Some vapor barrier materials do not, nor are they expected to, withstand those temperatures. Therefore, this evaluation shall only be made on insulated roof deck without the vapor barrier in place.

26. Apparatus

26.1 *Testing Machine, Loading Blocks, and Supports*—The equipment for test, except for the accelerated aging cycling, shall be the same as that used for the equivalent uniform load test (Sections 8-12).

26.2 *Accelerated Aging Chamber*—A closed chamber or tank with suitable facilities and controls for maintaining water at 120°F (49°C) and a mixing valve and distribution pipe in the tank for spraying specimens with steam and water vapor. A circulating-air furnace or dryer for drying specimens at 210°F (99°C) and a freezing unit is also required.

26.3 *Racks or Specimen Holders*—Wood-slatted racks or screened enclosures for holding and supporting specimens during accelerated aging in the horizontal position so they are not damaged by handling. Because of the dimensional changes during the aging exposure it is necessary that the racks permit this movement without restraint.

27. Procedure

27.1 *Accelerated Aging Exposure*—Subject each specimen to six complete cycles of aging. For each cycle treat the specimen as follows:

27.1.1 Immerse in water at $120 \pm 3^\circ\text{F}$ ($49 \pm 1.5^\circ\text{C}$) for 1 h,
 27.1.2 Spray with steam and water vapor at $200 \pm 5^\circ\text{F}$ ($93 \pm 3^\circ\text{C}$) for 3 h,

27.1.3 Store at $10 \pm 5^\circ\text{F}$ ($-12 \pm 3^\circ\text{C}$) for 20 h.

27.1.4 Heat at $210 \pm 3^\circ\text{F}$ ($99 \pm 1.5^\circ\text{C}$) in dry air for 3 h,

27.1.5 Spray again with steam and water vapor at $200 \pm 5^\circ\text{F}$ for 3 h, and

27.1.6 Heat in dry air at $210 \pm 3^\circ\text{F}$ for 18 h. After the six cycles of aging, condition the specimens to equilibrium moisture content as prescribed in 7.1.

27.2 Test the specimens under the same spans, quarter-point loading, using the same speeds as for equivalent uniform load of unaged specimens (Section 10). Take care to ensure uniform bearing at supports and under load points if there is appreciable warping or twisting. The obtaining of the load-deflection curve is not required unless it is deemed desirable to compare stiffness before and after the aging.

28. Calculation

28.1 *Modulus of Rupture*—Calculate values of modulus of rupture after aging, R_a , as indicated by the equation of 11.1, using the dimensions of the specimens before aging and the values for maximum load obtained from loading from aged specimens.

28.2 *Relation of Modulus of Rupture of Aged to Unaged Specimens*—Calculate the percentage retention in modulus of rupture due to accelerated aging as follows:

$$\begin{aligned} \text{Retention of modulus of rupture after aging percent} & \quad (5) \\ & = (R_a \times 100)/R \end{aligned}$$

where:

R = modulus of rupture for unaged specimens of the equivalent uniform load test, and

R_a = modulus of rupture for the matched but aged specimens.

29. Report

29.1 The report shall include individual values of the modulus of rupture after accelerated aging (R_a) and the percentage retention after aging. The nature of failure at maximum load shall be described.

THERMAL CONDUCTANCE

30. Scope

30.1 This method covers determination of the thermal conductivity of insulating roof deck. The physical limitations of some guarded hot plate equipment will not permit the evaluation of materials as thick as roof deck. When this is so, it will be permissible to determine conductances of the individual components of the deck and to calculate the overall conductance by adding resistances of the individual units.

31. Procedure

31.1 Determine the thermal conductance of the specimen at a mean temperature of 75°F (22.7°C) in accordance with Test Method C 177, which is the guarded hot plate method.

32. Report

32.1 Report the nominal thickness, the actual thickness, and the thermal conductance in $\text{Btu}/\text{h}\cdot\text{ft}^2 \cdot ^\circ\text{F}$ for each specimen tested.

WATER VAPOR PERMEANCE

33. Scope

33.1 This method covers determination of the vapor permeability of insulating roof deck. Because of the edge and end joints in a deck as installed, the effective permeance is a combination of the values obtained for the material itself and the values from specimens with end joints and side joints. The test method specified (C 355) limits the total thickness of the specimen to $1\frac{1}{4}$ in. (32 mm). For the evaluation of insulating deck of 3 in. (76 mm) or less in nominal thickness, that requirement is waived. Also, Test Methods C 355 permit the choice of either the Desiccant or Water Method of evaluating transmission of vapor, depending on which is most representative of use conditions. In the instance of insulating roof deck, the Desiccant Method most closely approximates conditions of use and shall be used.

34. Apparatus

34.1 *Test Pan*—The test pan shall be capable of taking an $11\frac{3}{8}$ by $11\frac{3}{8}$ -in. (288 by 288-mm) specimen and shall conform to the requirements of Test Methods C 355 (see Fig. 1 or Test Methods C 355).

34.2 *Other Equipment*—As prescribed in Methods C 355.

35. Procedure

35.1 *General*—Determine the property of water vapor permeance of the insulating roof deck slab by the Desiccant Method (dry cup) of Test Methods C 355, giving the result in average perms for a whole 2 by 8-ft (61 by 244-cm) unit. The insulating roof deck slab shall be interpreted as comprising a weighted combination of joint and board.

35.2 *Board Water Vapor Passage*—Determine the passage of water vapor through the board without joints on $11\frac{3}{8}$ by $11\frac{3}{8}$ -in. (288 by 288-mm) specimens of the slab having edges square and sealed in test pan and expressed as grains/ $\text{ft}^2\cdot\text{h}\cdot\text{in. Hg}$.

35.3 *Lateral Joint Water Vapor Passage*—The passage of water vapor through lateral joint shall be obtained from the total passage of vapor through a specimen having representative lateral joint, reduced by the passage through board only (from 35.2), and expressed as grains/linear ft $\cdot\text{h}\cdot\text{in. Hg}$.

35.4 *End Joint Water Vapor Passage*—Obtain the passage of water vapor through end joint from the total passage of vapor through a specimen having representative end joint, reduced by the passage through board only (from 35.2) and expressed as grains/linear ft $\cdot\text{h}\cdot\text{in. Hg}$.

36. Calculation

36.1 Calculate the effective water vapor permeance for the 2 by 8-ft (61 by 244-cm) slab as a whole as follows:

$$\text{Effective permeance, perms} = (8A + 4B + C)/8 \quad (6)$$

where:

- A = board water vapor passage,
- B = lateral joint water vapor passage, and
- C = end joint water vapor passage.

37. Report

37.1 Report the individual values obtained for effective permeance, board water vapor passage, lateral joint water vapor passage, and end joint water vapor passage. The effective permeance for a slab of a given thickness shall be the average for all the specimens of that thickness.

ASTM International takes no position respecting the validity of any patent rights asserted in connection with any item mentioned in this standard. Users of this standard are expressly advised that determination of the validity of any such patent rights, and the risk of infringement of such rights, are entirely their own responsibility.

This standard is subject to revision at any time by the responsible technical committee and must be reviewed every five years and if not revised, either reapproved or withdrawn. Your comments are invited either for revision of this standard or for additional standards and should be addressed to ASTM International Headquarters. Your comments will receive careful consideration at a meeting of the responsible technical committee, which you may attend. If you feel that your comments have not received a fair hearing you should make your views known to the ASTM Committee on Standards, at the address shown below.

This standard is copyrighted by ASTM International, 100 Barr Harbor Drive, PO Box C700, West Conshohocken, PA 19428-2959, United States. Individual reprints (single or multiple copies) of this standard may be obtained by contacting ASTM at the above address or at 610-832-9585 (phone), 610-832-9555 (fax), or service@astm.org (e-mail); or through the ASTM website (www.astm.org).

38. Precision and Bias

38.1 The precision and bias of these test methods have not yet been established. When data are available, such a statement will be included.

39. Keywords

39.1 cellulosic fiberboard; decorative roof deck; insulating roof deck; structural roof deck