



Standard Practice for Establishing Structural Grades and Related Allowable Properties for Visually Graded Lumber¹

This standard is issued under the fixed designation D 245; the number immediately following the designation indicates the year of original adoption or, in the case of revision, the year of last revision. A number in parentheses indicates the year of last reapproval. A superscript epsilon (ε) indicates an editorial change since the last revision or reapproval.

This standard has been approved for use by agencies of the Department of Defense.

^{ε1} NOTE—Ref (9) was added in September 2002.

1. Scope

1.1 This practice (1,2)² covers the basic principles for establishing related unit stresses and stiffness values for design with visually-graded solid sawn structural lumber. This practice starts with property values from clear wood specimens and includes necessary procedures for the formulation of structural grades of any desired strength ratio.

1.2 The grading provisions used as illustrations herein are not intended to establish grades for purchase, but rather to show how stress-grading principles are applied. Detailed grading rules for commercial stress grades which serve as purchase specifications are established and published by agencies which formulate and maintain such rules and operate inspection facilities covering the various species.

1.3 The material covered in this practice appears in the following order:

| | Section |
|---|---------|
| Scope | 1 |
| Significance and Use | 3 |
| Basic Principles of Strength Ratios | 4 |
| Estimation and Limitation of Growth Characteristics | 5 |
| Allowable Properties for Timber Design | 6 |
| Modification of Allowable Properties for Design Use | 7 |
| Example of Stress-Grade Development | 8 |

1.4 The values given in parentheses are provided for information purposes only.

1.5 *This standard does not purport to address all of the safety concerns, if any, associated with its use. It is the responsibility of the user of this standard to establish appropriate safety and health practices and determine the applicability of regulatory limitations prior to use.*

¹ This practice is under the jurisdiction of ASTM Committee D07 on Wood and is the direct responsibility of Subcommittee D07.02 on Lumber and Engineered Wood Products.

Current edition approved April 10, 2000. Published June 2000. Originally published as D 245 – 26. Last previous edition D 245 – 99.

² The boldface numbers in parentheses refer to references at the end of this practice.

2. Referenced Documents

2.1 ASTM Standards:

- D 9 Terminology Relating to Wood³
- D 143 Methods of Testing Small Clear Specimens of Timber³
- D 2555 Test Methods for Establishing Clear-Wood Strength Values³
- E 105 Practice for Probability Sampling of Materials⁴
- E 380 Practice for Use of the International System of Units (SI) (the Modernized Metric System)⁵

3. Significance and Use

3.1 Need for Lumber Grading:

3.1.1 Individual pieces of lumber, as they come from the saw, represent a wide range in quality and appearance with respect to freedom from knots, cross grain, shakes, and other characteristics. Such random pieces likewise represent a wide range in strength, utility, serviceability, and value. One of the obvious requirements for the orderly marketing of lumber is the establishment of grades that permit the procurement of any required quality of lumber in any desired quantity. Maximum economy of material is obtained when the range of quality-determining characteristics in a grade is limited and all pieces are utilized to their full potential. Many of the grades are established on the basis of appearance and physical characteristics of the piece, but without regard for mechanical properties. Other grades, called structural or stress grades, are established on the basis of features that relate to mechanical properties. The latter designate near-minimum strength and near-average stiffness properties on which to base structural design.

3.1.2 The development of this practice is based on extensive research covering tests of small clear specimens and of full-sized structural members. Detailed studies have included

³ *Annual Book of ASTM Standards*, Vol 04.10.

⁴ *Annual Book of ASTM Standards*, Vol 14.02.

⁵ *Annual Book of ASTM Standards*, Vol 14.02 (excerpts in Vol 04.10).

the strength and variability of clear wood, and the effect on strength from various factors such as density, knots (See Terminology D 9), and other defects, seasoning, duration of stress, and temperature.

3.2 *How Visual Grading is Accomplished*— Visual grading is accomplished from an examination of all four faces and the ends of the piece, in which the location as well as the size and nature of the knots and other features appearing on the surfaces are evaluated over the entire length. Basic principles of structural grading have been established that permit the evaluation of any piece of stress-graded lumber in terms of a strength ratio for each property being evaluated. The strength ratio of stress-graded lumber is the hypothetical ratio of the strength property being considered compared to that for the material with no strength-reducing characteristic. Thus a piece of stress-graded lumber with a strength ratio of 75 % in bending would be expected to have 75 % of the bending strength of the clear piece. In effect, the strength ratio system of visual structural grading is thus designed to permit practically unlimited choice in establishing grades of any desired quality to best meet production and utilization requirements.

3.3 *Classification of Stress-Graded Lumber:*

3.3.1 The various factors affecting strength, such as knots, deviations of grain, shakes, and checks, differ in their effect, depending on the kind of loading and stress to which the piece is subjected. Stress-graded lumber is often classified according to its size and use. Four classes are widely used, as follows:

3.3.1.1 *Dimension Lumber*—Pieces of rectangular cross section, from nominal 2 to 4 in. thick and 2 or more in. wide, graded primarily for strength in bending edgewise or flatwise, but also frequently used where tensile or compressive strength is important. Dimension lumber covers many sizes and end uses. Lumber graded for specific end uses may dictate a special emphasis in grading and require an identifying grade name.

NOTE 1—For example, in North American grading under the American Lumber Standards Committee, stress graded dimension lumber categories that reflect end use include Light Framing, Structural Light Framing, Structural Joists and Planks, and Studs.

3.3.1.2 *Beams and Stringers*—Pieces of rectangular cross section, 5 in. nominal and thicker, nominal width more than 2 in. greater than nominal thickness, graded for strength in bending when loaded on the narrow face.

3.3.1.3 *Posts and Timbers*—Pieces of square or nearly square cross section, 5 by 5 in., nominal dimensions and larger, nominal width not more than 2 in. greater than nominal thickness, graded primarily for use as posts or columns.

3.3.1.4 *Stress-Rated Boards*—Lumber less than 2 in. nominal in thickness and 2 in. or wider nominal width, graded primarily for mechanical properties.

3.3.2 The assignment of names indicating the uses for the various classes of stress-graded lumber does not preclude their use for other purposes. For example, posts and timbers may give service as beams. The principles of stress grading permit the assignment of any kind of allowable properties to any of the classes of stress-graded lumber, whether graded primarily for that property or not. Recommendations for allowable properties may include all properties for all grades or use classes. While such universal application may result in loss of effi-

ciency in some particulars, it offers the advantage of a more simple system of grades of stress-graded lumber.

3.4 *Essential Elements in a Stress-Grade Description:*

3.4.1 A stress grade formulated by this practice contains the following essential elements:

3.4.2 A grade name that identifies the use-class as described in 3.3.

3.4.3 A description of permissible growth characteristics that affect mechanical properties. Characteristics that do not affect mechanical properties may also be included.

3.4.4 One or more allowable properties for the grade related to its strength ratio.

4. **Basic Principles of Strength Ratios**

4.1 *General Considerations:*

4.1.1 Strength ratios associated with knots in bending members have been derived as the ratio of moment-carrying capacity of a member with cross section reduced by the largest knot to the moment-carrying capacity of the member without defect. This gives the anticipated reduction in bending strength due to the knot. For simplicity, all knots on the wide face are treated as being either knots along the edge of the piece (edge knots) or knots along the centerline of the piece (centerline knots).

4.1.2 Strength ratios associated with slope of grain in bending members, and in members subjected to compression parallel to grain, were obtained, experimentally (3).

4.1.3 Strength ratios associated with shakes, checks, and splits are assumed to affect only horizontal shear in bending members. These strength ratios were derived, as for knots, by assuming that a critical cross section is reduced by the amount of the shake, or by an equivalent split or check.

4.1.4 Strength ratios associated with knots in compression members have been derived as the ratio of load-carrying capacity of a member with cross section reduced by the largest knot to the load-carrying capacity of the member without defect. No assumption of combined compression and bending is made.

4.1.5 Tensile strength of lumber has been related to bending strength and bending strength ratio from experimental results (4).

4.1.6 Strength in compression perpendicular to grain is little affected in lumber by strength-reducing characteristics, and strength ratios of 100 % are assumed for all grades.

4.1.7 Modulus of elasticity of a piece of lumber is known to be only approximately related to bending strength ratio. In this standard, the relationship between full-span, edgewise bending modulus of elasticity and strength ratio was obtained experimentally.

4.1.8 In developing a stress-grade rule, economy may be served by specifying strength ratios such that the allowable stresses for shear and for extreme fiber in bending will be in balance, under the loading for which the members are designed.

4.1.9 A strength ratio can also be associated with specific gravity. Three selection classes called dense, close grain, and medium grain are described herein, based on experimental findings (5).

4.2 *Strength Ratios:*

4.2.1 Table 1 gives strength ratios, corresponding to various slopes of grain for stress in bending and compression parallel to grain.

4.2.2 Strength ratios for various combinations of size and location of knot and width of face are given in Table 2, Table 3, and Table 4. Since interpolation is often required in the development of grading rules, the use of formulas in Table 2, Table 3 and Table 4 is acceptable. These formulas are found in the Appendix.

4.2.2.1 Use of the tables is illustrated by the following example: The sizes of knots permitted in a 7½ by 15½-in. (190 by 394-mm) (actual) beam in a grade having a strength ratio of 70 % in bending are desired. The smallest ratio in the column for a 7½-in. (190-mm) face in Table 2 that equals or exceeds 70 % is opposite 2⅛ in. (54 mm) in the size-of-knot column. A similar ratio in the column for 15½-in. (394-mm) face in Table 3 is opposite 4¼ in. (108 mm). Hence, the permissible sizes are 2⅛ in. (54 mm) on the 7½-in. (190-mm) face and at the edge of the wide face (see 5.3.5.2) and 4¼ in. (108 mm) on the centerline of the 15½-in. (394-mm) face.

4.2.3 For all lumber thicknesses, a strength ratio of 50 % shall be used for all sizes of shakes, checks and splits. A 50 % strength ratio is the maximum effect a shake, check or split can have on the load-carrying capacity of a bending member. Limitations in grading rules placed on the characteristics at time of manufacture are for appearance and general utility purposes, and these characteristics shall not be used as a basis for increasing lumber shear design values.

NOTE 2—The factor of 0.5 (50 %) is not strictly a “strength ratio” for horizontal shear, since the factor represents more than just the effects of shakes, checks and splits. The factor also includes differences between test values obtained in Methods D 143 shear block tests and full-size solid-sawn beam shear tests. The strength ratio terminology is retained for compatibility with prior versions of Practice D 245, but prior provisions permitting design increases for members with lesser-size cracks have been deleted since the factor is related to more than shakes, checks and splits.

4.2.4 Modulus of elasticity is modified by a quality factor that is related to bending strength ratio, as given in Table 5.

4.2.5 Strength ratios in tension parallel to grain are 55 % of the corresponding bending strength ratios.

4.2.6 Table 6 gives strength ratios and quality factors for the special specific gravity classes described in 4.1.9.

5. Estimation and Limitation of Growth Characteristics

5.1 General Quality of Lumber:

5.1.1 All lumber should be well manufactured.

5.1.2 Only sound wood, free from any form of decay, shall be permitted, unless otherwise specified. Unsound knots and limited amounts of decay in its early stages are permitted in some of the lower stress-rated grades of lumber intended for light frame construction.

5.1.3 In stress-grading, all four faces and the ends shall be considered.

5.2 Slope of Grain:

5.2.1 Slope of grain resulting from either diagonal sawing or from spiral or twisted grain in the tree is measured by the angle between the direction of the fibers and the edge of the piece. The angle is expressed as a slope. For instance, a slope of grain of 1 in 15 means that the grain deviates 1 in. (2.5 mm) from the edge in 15 in. (381 mm) of length.

5.2.2 When both diagonal and spiral grain are present, the combined slope of grain is taken as the effective slope.

5.2.3 Slope of grain is measured and limited at the zone in the length of a structural timber that shows the greatest slope. It shall be measured over a distance sufficiently great to define the general slope, disregarding such short local deviations as those around knots except as indicated in 5.2.5.

5.2.4 In 1-in. nominal boards (See Terminology D 9), or similar small sizes of lumber, a general slope of grain anywhere in the length shall not pass completely through the thickness of the piece in a longitudinal distance in inches less than the number expressing the specified permissible slope. Where such a slope varies across the width of the board, its average may be taken.

5.2.5 Local deviations must be considered in small sizes, and if a local deviation occurs in a piece less than 4 in. nominal in width or on the narrow face of a piece less than 2 in. nominal in thickness, and is not associated with a permissible knot in the piece, the measurement of slope shall include the local deviation.

5.3 Knots:

5.3.1 A knot cluster is treated as an individual knot. Two or more knots closely spaced, with the fibers deflected around each knot individually, are not a cluster.

5.3.2 Holes associated with knots are measured and limited in the same way as knots.

5.3.3 A knot on the wide face of a bending or tension member is considered to be at the edge of the wide face if the center of the knot lies within two thirds of the knot diameter from the edge.

5.3.4 Knots in Dimension Lumber:

5.3.4.1 Knots in dimension lumber may be measured by displacement method, in which the proportion of the cross section of the knot to the cross section of the piece is multiplied by actual face width to establish the equivalent knot size (see Fig. 1). This value is used in the strength ratio tables.

5.3.4.2 Alternatively, knots in dimension lumber may be measured on the surface of the piece. Methods of measuring knots by this alternative are given in 5.3.4.3-5.3.4.5.

TABLE 1 Strength Ratios Corresponding to Various Slopes of Grain

| Slope of Grain | Maximum Strength Ratio, % | |
|----------------|--------------------------------------|-------------------------------|
| | Bending or Tension Parallel to Grain | Compression Parallel to Grain |
| 1 in 6 | 40 | 56 |
| 1 in 8 | 53 | 66 |
| 1 in 10 | 61 | 74 |
| 1 in 12 | 69 | 82 |
| 1 in 14 | 74 | 87 |
| 1 in 15 | 76 | 100 |
| 1 in 16 | 80 | ... |
| 1 in 18 | 85 | ... |
| 1 in 20 | 100 | ... |



TABLE 2 Strength Ratios Corresponding to Knots in the Narrow Face of Bending Members

| Knot Size, in. (mm) ^A | Percentage Strength Ratio When Actual Width of Narrow Face, in. (mm), is ^A | | | | | | | | | | | | | | | | | | | | | | | | | | | | |
|----------------------------------|---|------------|-----------|------------|-----------|------------|------------|-------------|------------|-------------|------------|------------|-------------|------------|------------|-------------|-------------|-------------|--------------|-------------|-------------|--------------|-------------|-------------|--------------|-------------|----|----|----|
| | 1 (25) | 1½ (38) | 2 (51) | 2½ (64) | 3 (76) | 3½ (89) | 4 (102) | 4½ (114) | 5 (127) | 5½ (140) | 6 (152) | 7 (178) | 7½ (190) | 8 (203) | 9 (229) | 9½ (241) | 10 (254) | 11 (279) | 11½ (292) | 12 (305) | 13 (330) | 13½ (343) | 14 (356) | 15 (381) | 15½ (394) | 16 (406) | | | |
| 1/4(6) | 85 | 89 | 91 | 93 | 94 | 95 | 95 | 96 | 96 | 96 | 97 | 97 | 97 | 97 | 97 | 97 | 97 | 97 | 98 | 98 | 98 | 98 | 98 | 98 | 98 | 98 | 98 | 98 | |
| 1/2(13) | 67 | 76 | 81 | 84 | 86 | 88 | 90 | 91 | 91 | 92 | 93 | 93 | 93 | 94 | 94 | 94 | 94 | 94 | 95 | 95 | 95 | 95 | 95 | 95 | 95 | 95 | 95 | 95 | |
| 3/4(19) | 48 | 62 | 70 | 75 | 79 | 82 | 84 | 85 | 87 | 88 | 89 | 89 | 90 | 90 | 91 | 91 | 91 | 91 | 92 | 92 | 92 | 92 | 92 | 92 | 93 | 93 | 93 | 93 | |
| 1 (25) | 4 | 49 | 60 | 68 | 72 | 75 | 78 | 80 | 82 | 84 | 85 | 86 | 86 | 87 | 88 | 88 | 88 | 88 | 89 | 89 | 89 | 89 | 90 | 90 | 90 | 90 | 90 | 90 | |
| 1¼(32) | ... | ... | 49 | 58 | 64 | 69 | 72 | 75 | 78 | 79 | 81 | 82 | 83 | 83 | 84 | 84 | 85 | 85 | 86 | 86 | 86 | 87 | 87 | 87 | 87 | 88 | 88 | 88 | |
| 1½(38) | ... | ... | 27 | 49 | 57 | 62 | 67 | 70 | 73 | 75 | 77 | 78 | 79 | 80 | 81 | 81 | 82 | 82 | 83 | 83 | 83 | 84 | 84 | 84 | 85 | 85 | 85 | 85 | |
| 1¾(44) | ... | ... | 15 | 32 | 49 | 56 | 61 | 65 | 68 | 71 | 73 | 75 | 75 | 76 | 77 | 78 | 78 | 79 | 80 | 80 | 81 | 81 | 82 | 82 | 82 | 83 | 83 | 83 | |
| 2 (51) | ... | ... | ... | 22 | 35 | 49 | 55 | 60 | 64 | 67 | 69 | 71 | 72 | 73 | 74 | 75 | 75 | 76 | 77 | 77 | 78 | 79 | 79 | 79 | 80 | 80 | 80 | 80 | |
| 2¼(57) | ... | ... | ... | ... | 26 | 37 | 50 | 55 | 59 | 62 | 65 | 67 | 68 | 69 | 71 | 71 | 72 | 73 | 74 | 75 | 75 | 76 | 76 | 77 | 77 | 77 | 78 | 78 | |
| 2½(64) | ... | ... | ... | ... | 18 | 30 | 39 | 50 | 54 | 58 | 61 | 63 | 64 | 66 | 67 | 68 | 69 | 70 | 71 | 72 | 73 | 73 | 74 | 74 | 75 | 75 | 75 | 75 | |
| 2¾(70) | ... | ... | ... | ... | ... | 23 | 32 | 40 | 50 | 54 | 57 | 60 | 61 | 62 | 64 | 65 | 66 | 67 | 68 | 69 | 70 | 70 | 71 | 72 | 72 | 72 | 73 | 73 | |
| 3 (76) | ... | ... | ... | ... | ... | ... | 26 | 34 | 41 | 50 | 53 | 56 | 57 | 59 | 61 | 62 | 63 | 64 | 65 | 66 | 67 | 68 | 68 | 69 | 69 | 70 | 70 | 70 | |
| 3¼(83) | ... | ... | ... | ... | ... | ... | ... | 36 | 45 | 49 | 55 | 54 | 54 | 55 | 57 | 59 | 60 | 61 | 62 | 63 | 64 | 65 | 66 | 67 | 67 | 67 | 68 | 68 | |
| 3½(89) | ... | ... | ... | ... | ... | ... | ... | ... | 37 | 46 | 52 | 48 | 50 | 52 | 54 | 55 | 56 | 58 | 59 | 60 | 62 | 62 | 63 | 64 | 64 | 65 | 65 | 65 | |
| 3¾(95) | ... | ... | ... | ... | ... | ... | ... | ... | ... | ... | 45 | 45 | 46 | 48 | 51 | 52 | 53 | 55 | 56 | 57 | 59 | 60 | 60 | 61 | 61 | 62 | 63 | 63 | |
| 4 (102) | ... | ... | ... | ... | ... | ... | ... | ... | ... | ... | ... | ... | ... | 45 | 48 | 49 | 50 | 52 | 53 | 54 | 54 | 55 | 55 | 55 | 56 | 56 | 57 | 58 | 60 |
| 4¼(108) | ... | ... | ... | ... | ... | ... | ... | ... | ... | ... | ... | ... | ... | ... | ... | 46 | 47 | 49 | 50 | 51 | 51 | 51 | 51 | 52 | 52 | 52 | 52 | 53 | 55 |
| 4½(114) | ... | ... | ... | ... | ... | ... | ... | ... | ... | ... | ... | ... | ... | ... | ... | ... | ... | 46 | 47 | 49 | 50 | 50 | 51 | 51 | 51 | 51 | 51 | 51 | 51 |
| 4¾(121) | ... | ... | ... | ... | ... | ... | ... | ... | ... | ... | ... | ... | ... | ... | ... | ... | ... | ... | ... | 46 | 48 | 48 | 49 | 49 | 50 | 50 | 50 | 50 | |
| 5 (127) | ... | ... | ... | ... | ... | ... | ... | ... | ... | ... | ... | ... | ... | ... | ... | ... | ... | ... | ... | 46 | 45 | 45 | 46 | 47 | 49 | 49 | 49 | 49 | |

^ARatios corresponding to other sizes of knots and face widths can be found by linear interpolation.

TABLE 3 Strength Ratios Corresponding to Centerline Knots in the Wide Face of Bending Members, and to Knots in Compression Members

| Size of Knot, in. (mm) ^A | Percentage Strength Ratio When Actual Width of Wide Face, in. (mm), is ^A | | | | | | | | | | | | | | | | | | | | | | | | | | |
|-------------------------------------|---|------------|------------|-------------|------------|-------------|------------|------------|-------------|------------|------------|-------------|-------------|-------------|--------------|-------------|-------------|--------------|-------------|-------------|--------------|-------------|-------------|-------------|-------------|-------------|----|
| | 3 (76) | 3½ (89) | 4 (102) | 4½ (114) | 5 (127) | 5½ (140) | 6 (152) | 7 (178) | 7½ (190) | 8 (203) | 9 (229) | 9½ (241) | 10 (254) | 11 (279) | 11½ (292) | 12 (302) | 13 (330) | 13½ (343) | 14 (356) | 15 (381) | 15½ (394) | 16 (406) | 18 (457) | 20 (508) | 22 (559) | 24 (610) | |
| ¼(6) | 94 | 95 | 95 | 96 | 96 | 97 | 97 | 97 | 97 | 97 | 98 | 98 | 98 | 98 | 98 | 98 | 98 | 98 | 98 | 98 | 98 | 98 | 99 | 99 | 99 | 99 | 99 |
| ½(13) | 86 | 88 | 90 | 91 | 91 | 92 | 93 | 94 | 94 | 95 | 95 | 95 | 96 | 96 | 96 | 96 | 96 | 96 | 97 | 97 | 97 | 97 | 97 | 97 | 97 | 97 | 97 |
| ¾(19) | 79 | 82 | 84 | 85 | 87 | 88 | 89 | 91 | 91 | 92 | 92 | 93 | 93 | 94 | 94 | 94 | 94 | 95 | 95 | 95 | 95 | 95 | 95 | 95 | 95 | 95 | 96 |
| 1 (25) | 72 | 75 | 78 | 80 | 82 | 84 | 85 | 87 | 88 | 89 | 90 | 90 | 91 | 92 | 92 | 92 | 93 | 93 | 93 | 93 | 93 | 93 | 93 | 94 | 94 | 94 | 94 |
| 1¼(32) | 64 | 69 | 72 | 75 | 78 | 79 | 81 | 84 | 85 | 86 | 87 | 88 | 89 | 90 | 90 | 91 | 91 | 91 | 91 | 91 | 91 | 91 | 92 | 92 | 92 | 93 | 93 |
| 1½(38) | 57 | 62 | 67 | 70 | 73 | 75 | 78 | 81 | 82 | 83 | 85 | 86 | 87 | 88 | 88 | 89 | 89 | 89 | 89 | 89 | 89 | 90 | 90 | 91 | 91 | 91 | 91 |
| 1¾(44) | 49 | 56 | 61 | 65 | 68 | 71 | 74 | 77 | 79 | 80 | 82 | 83 | 84 | 85 | 86 | 86 | 87 | 87 | 87 | 87 | 88 | 88 | 89 | 89 | 89 | 90 | 90 |
| 2 (51) | 35 | 49 | 55 | 60 | 64 | 67 | 70 | 74 | 76 | 77 | 79 | 80 | 81 | 83 | 84 | 84 | 85 | 85 | 85 | 86 | 86 | 86 | 87 | 88 | 88 | 88 | 89 |
| 2¼(57) | 26 | 37 | 50 | 55 | 59 | 62 | 66 | 71 | 72 | 73 | 77 | 78 | 79 | 81 | 82 | 82 | 83 | 83 | 83 | 84 | 84 | 84 | 85 | 86 | 87 | 87 | 88 |
| 2½(64) | 18 | 30 | 39 | 50 | 54 | 58 | 62 | 67 | 69 | 71 | 74 | 75 | 77 | 79 | 80 | 80 | 81 | 81 | 81 | 82 | 82 | 82 | 83 | 84 | 84 | 85 | 86 |
| 2¾(70) | ... | 23 | 32 | 40 | 50 | 54 | 58 | 64 | 66 | 68 | 71 | 73 | 74 | 76 | 77 | 78 | 79 | 79 | 79 | 80 | 80 | 80 | 81 | 82 | 83 | 84 | 84 |
| 3 (76) | ... | ... | 26 | 34 | 41 | 50 | 54 | 61 | 63 | 65 | 69 | 70 | 72 | 74 | 75 | 76 | 77 | 77 | 78 | 78 | 78 | 79 | 80 | 81 | 82 | 83 | 83 |
| 3¼(83) | ... | ... | ... | 29 | 36 | 45 | 51 | 57 | 60 | 62 | 66 | 68 | 69 | 72 | 73 | 74 | 75 | 75 | 76 | 76 | 77 | 77 | 78 | 80 | 80 | 80 | 81 |
| 3½(89) | ... | ... | ... | 23 | 31 | 37 | 47 | 54 | 57 | 59 | 64 | 65 | 67 | 70 | 71 | 72 | 73 | 73 | 74 | 75 | 75 | 75 | 77 | 78 | 79 | 80 | 81 |
| 3¾(95) | ... | ... | ... | ... | 26 | 32 | 38 | 51 | 54 | 56 | 61 | 63 | 65 | 68 | 69 | 70 | 71 | 71 | 72 | 73 | 73 | 73 | 74 | 75 | 76 | 77 | 78 |
| 4 (102) | ... | ... | ... | ... | 21 | 28 | 34 | 47 | 50 | 53 | 58 | 60 | 62 | 66 | 67 | 68 | 69 | 69 | 70 | 71 | 71 | 71 | 72 | 73 | 75 | 76 | 77 |
| 4¼(108) | ... | ... | ... | ... | ... | 23 | 30 | 40 | 46 | 50 | 56 | 58 | 60 | 63 | 65 | 66 | 67 | 68 | 68 | 69 | 70 | 70 | 70 | 72 | 73 | 74 | 75 |
| 4½(114) | ... | ... | ... | ... | ... | 19 | 26 | 36 | 41 | 48 | 53 | 55 | 58 | 61 | 63 | 64 | 65 | 66 | 66 | 67 | 68 | 68 | 70 | 72 | 73 | 74 | 74 |
| 4¾(121) | ... | ... | ... | ... | ... | ... | 21 | 33 | 37 | 41 | 50 | 53 | 55 | 59 | 61 | 62 | 63 | 64 | 64 | 65 | 66 | 66 | 67 | 68 | 70 | 71 | 73 |
| 5 (127) | ... | ... | ... | ... | ... | 17 | 25 | 29 | 34 | 38 | 48 | 50 | 53 | 57 | 59 | 60 | 61 | 62 | 62 | 64 | 64 | 65 | 67 | 68 | 70 | 71 | 71 |
| 5¼(133) | ... | ... | ... | ... | ... | ... | 22 | 32 | 35 | 35 | 45 | 48 | 50 | 55 | 57 | 58 | 59 | 60 | 61 | 62 | 62 | 63 | 65 | 67 | 68 | 70 | 71 |
| 5½(140) | ... | ... | ... | ... | ... | ... | 22 | 32 | 32 | 32 | 45 | 48 | 50 | 55 | 57 | 58 | 59 | 60 | 61 | 61 | 61 | 61 | 63 | 65 | 67 | 68 | 68 |
| 5¾(146) | ... | ... | ... | ... | ... | ... | 22 | 32 | 32 | 32 | 45 | 48 | 50 | 55 | 57 | 58 | 59 | 60 | 61 | 61 | 61 | 61 | 63 | 65 | 67 | 68 | 68 |
| 6 (152) | ... | ... | ... | ... | ... | ... | 22 | 32 | 32 | 32 | 45 | 48 | 50 | 55 | 57 | 58 | 59 | 60 | 61 | 61 | 61 | 61 | 63 | 65 | 67 | 68 | 68 |
| 6½(165) | ... | ... | ... | ... | ... | ... | 22 | 32 | 32 | 32 | 45 | 48 | 50 | 55 | 57 | 58 | 59 | 60 | 61 | 61 | 61 | 61 | 63 | 65 | 67 | 68 | 68 |
| 7 (178) | ... | ... | ... | ... | ... | ... | 22 | 32 | 32 | 32 | 45 | 48 | 50 | 55 | 57 | 58 | 59 | 60 | 61 | 61 | 61 | 61 | 63 | 65 | 67 | 68 | 68 |
| 7½(190) | ... | ... | ... | ... | ... | ... | 22 | 32 | 32 | 32 | 45 | 48 | 50 | 55 | 57 | 58 | 59 | 60 | 61 | 61 | 61 | 61 | 63 | 65 | 67 | 68 | 68 |
| 8 (203) | ... | ... | ... | ... | ... | ... | 22 | 32 | 32 | 32 | 45 | 48 | 50 | 55 | 57 | 58 | 59 | 60 | 61 | 61 | 61 | 61 | 63 | 65 | 67 | 68 | 68 |
| 8½(216) | ... | ... | ... | ... | ... | ... | 22 | 32 | 32 | 32 | 45 | 48 | 50 | 55 | 57 | 58 | 59 | 60 | 61 | 61 | 61 | 61 | 63 | 65 | 67 | 68 | 68 |
| 9 (216) | ... | ... | ... | ... | ... | ... | 22 | 32 | 32 | 32 | 45 | 48 | 50 | 55 | 57 | 58 | 59 | 60 | 61 | 61 | 61 | 61 | 63 | 65 | 67 | 68 | 68 |

^ARatios corresponding to other sizes of knots and face widths can be found by linear interpolation.



TABLE 4 Strength Ratios Corresponding to Edge Knots in the Wide Face of Bending Members

| Knot Size, in. (mm) ^a | Percentage Strength Ratio When Actual Width of Wide Face, in. (mm), is ^a | | | | | | | | | | | | | | | | | | | | | | | | | | | | | | |
|----------------------------------|---|------------|-----------|------------|------------|-------------|------------|-------------|------------|------------|-------------|------------|------------|-------------|-------------|-------------|--------------|-------------|-------------|--------------|-------------|-------------|--------------|-------------|-------------|-------------|-------------|-------------|----|----|----|
| | 2 (51) | 2½ (64) | 3 (76) | 3½ (89) | 4 (102) | 4½ (114) | 5 (127) | 5½ (140) | 6 (152) | 7 (178) | 7½ (190) | 8 (203) | 9 (229) | 9½ (241) | 10 (254) | 11 (279) | 11½ (292) | 12 (305) | 13 (330) | 13½ (343) | 14 (356) | 15 (381) | 15½ (394) | 16 (406) | 18 (457) | 20 (508) | 22 (559) | 24 (610) | | | |
| 1/4(6) | 83 | 86 | 88 | 89 | 91 | 91 | 92 | 93 | 94 | 94 | 94 | 95 | 95 | 96 | 96 | 96 | 97 | 97 | 97 | 97 | 97 | 97 | 97 | 97 | 97 | 97 | 97 | 97 | 97 | 98 | |
| 1/2(13) | 65 | 71 | 75 | 78 | 80 | 82 | 84 | 85 | 86 | 88 | 89 | 90 | 90 | 91 | 91 | 92 | 92 | 93 | 93 | 93 | 93 | 93 | 93 | 93 | 94 | 94 | 94 | 94 | 94 | 95 | |
| 3/4(19) | 49 | 57 | 62 | 67 | 70 | 73 | 75 | 77 | 79 | 82 | 83 | 84 | 86 | 87 | 88 | 89 | 89 | 89 | 89 | 89 | 89 | 90 | 90 | 90 | 90 | 91 | 91 | 91 | 92 | 92 | |
| 1(25) | 27 | 38 | 51 | 57 | 61 | 65 | 68 | 70 | 73 | 76 | 77 | 79 | 81 | 82 | 83 | 84 | 85 | 85 | 85 | 86 | 86 | 86 | 86 | 87 | 87 | 88 | 88 | 89 | 89 | 89 | |
| 1½(32) | 16 | 27 | 36 | 47 | 52 | 57 | 60 | 63 | 66 | 71 | 72 | 74 | 76 | 77 | 78 | 80 | 81 | 82 | 82 | 83 | 83 | 83 | 83 | 84 | 84 | 84 | 85 | 86 | 86 | 86 | |
| 1¾(44) | ... | 17 | 26 | 34 | 40 | 49 | 53 | 57 | 60 | 64 | 67 | 69 | 72 | 73 | 74 | 76 | 77 | 78 | 78 | 79 | 79 | 79 | 80 | 80 | 80 | 81 | 82 | 83 | 84 | 84 | |
| 2(51) | ... | ... | 19 | 26 | 33 | 38 | 47 | 50 | 54 | 60 | 62 | 64 | 67 | 69 | 70 | 72 | 74 | 75 | 75 | 75 | 75 | 76 | 77 | 77 | 77 | 77 | 78 | 79 | 80 | 81 | 81 |
| 2½(64) | ... | ... | ... | 19 | 26 | 32 | 37 | 45 | 49 | 55 | 57 | 59 | 63 | 65 | 66 | 69 | 70 | 71 | 72 | 72 | 72 | 73 | 73 | 74 | 74 | 75 | 77 | 78 | 78 | 78 | |
| 3(76) | ... | ... | ... | ... | 20 | 26 | 31 | 36 | 40 | 50 | 52 | 55 | 59 | 61 | 62 | 65 | 66 | 68 | 68 | 69 | 69 | 70 | 71 | 71 | 71 | 73 | 74 | 75 | 76 | 76 | |
| 3½(89) | ... | ... | ... | ... | 15 | 21 | 26 | 31 | 35 | 45 | 48 | 51 | 55 | 57 | 59 | 62 | 63 | 65 | 65 | 66 | 66 | 67 | 67 | 68 | 68 | 70 | 71 | 72 | 73 | 73 | |
| 4(102) | ... | ... | ... | ... | ... | 16 | 21 | 26 | 30 | 38 | 41 | 46 | 51 | 53 | 55 | 59 | 60 | 61 | 62 | 63 | 63 | 64 | 64 | 65 | 65 | 67 | 68 | 70 | 71 | 71 | |
| 4½(108) | ... | ... | ... | ... | ... | ... | 17 | 21 | 26 | 33 | 37 | 40 | 47 | 50 | 52 | 55 | 57 | 58 | 59 | 60 | 60 | 60 | 61 | 62 | 62 | 64 | 66 | 67 | 68 | 68 | |
| 5(127) | ... | ... | ... | ... | ... | ... | ... | 17 | 22 | 29 | 32 | 36 | 41 | 46 | 48 | 52 | 54 | 55 | 56 | 57 | 57 | 57 | 58 | 59 | 60 | 62 | 63 | 65 | 66 | 66 | |
| 5½(114) | ... | ... | ... | ... | ... | ... | 18 | 22 | 29 | 32 | 36 | 41 | 46 | 48 | 48 | 49 | 49 | 50 | 50 | 51 | 51 | 52 | 53 | 54 | 56 | 59 | 61 | 62 | 63 | 63 | |
| 6(141) | ... | ... | ... | ... | ... | ... | ... | ... | ... | 23 | 26 | 29 | 32 | 39 | 41 | 43 | 46 | 48 | 48 | 49 | 49 | 50 | 51 | 52 | 54 | 56 | 58 | 60 | 61 | 61 | |
| 6½(164) | ... | ... | ... | ... | ... | ... | ... | ... | ... | ... | 22 | 26 | 29 | 34 | 37 | 40 | 44 | 46 | 46 | 48 | 48 | 49 | 50 | 51 | 52 | 54 | 56 | 58 | 59 | 59 | |
| 7(194) | ... | ... | ... | ... | ... | ... | ... | ... | ... | ... | ... | 22 | 28 | 31 | 34 | 38 | 40 | 42 | 44 | 45 | 45 | 46 | 48 | 49 | 51 | 54 | 56 | 58 | 59 | 59 | |
| 7½(221) | ... | ... | ... | ... | ... | ... | ... | ... | ... | ... | ... | 20 | 26 | 28 | 31 | 35 | 37 | 41 | 42 | 42 | 43 | 43 | 45 | 46 | 47 | 49 | 51 | 53 | 54 | 54 | |
| 8(254) | ... | ... | ... | ... | ... | ... | ... | ... | ... | ... | ... | ... | 23 | 26 | 28 | 31 | 35 | 37 | 39 | 40 | 41 | 42 | 45 | 46 | 47 | 49 | 51 | 53 | 54 | 54 | |
| 8½(281) | ... | ... | ... | ... | ... | ... | ... | ... | ... | ... | ... | ... | 23 | 26 | 28 | 31 | 33 | 35 | 37 | 39 | 40 | 41 | 42 | 44 | 44 | 47 | 49 | 51 | 52 | 52 | |
| 9(311) | ... | ... | ... | ... | ... | ... | ... | ... | ... | ... | ... | ... | ... | 25 | 28 | 30 | 32 | 34 | 36 | 37 | 37 | 38 | 40 | 40 | 41 | 44 | 47 | 49 | 51 | 51 | |
| 9½(341) | ... | ... | ... | ... | ... | ... | ... | ... | ... | ... | ... | ... | ... | ... | 25 | 30 | 32 | 34 | 36 | 37 | 38 | 40 | 40 | 41 | 41 | 44 | 47 | 49 | 51 | 51 | |

^aRatios corresponding to other sizes of knots and face widths can be found by linear interpolation.

TABLE 5 Quality Factors for Modulus of Elasticity

| Bending Strength Ratio, % | Quality Factor for Modulus of Elasticity, % |
|---------------------------|---|
| ≥55 | 100 |
| 45 to 54 | 90 |
| ≤44 | 80 |

TABLE 6 Strength Ratios and Quality Factors for Special Specific Gravity Classifications

| Property | Specific Gravity Classification, % | | |
|---|------------------------------------|-------------|--------------|
| | Dense | Close Grain | Medium Grain |
| Bending stress | 117 | 107 | 100 |
| Tensile stress parallel to grain | | | |
| Compressive stress parallel to grain | | | |
| Compressive stress perpendicular to grain | 105 | 100 | 100 |
| Modulus of elasticity | | | |

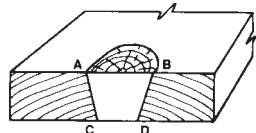

Wide Face Knots

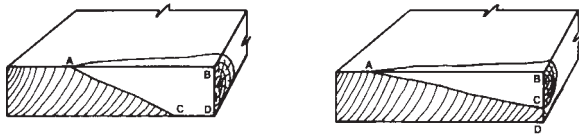

Spike Knots

FIG. 1 Measurement of Knots in Dimension Lumber Using Displacement Method (Primary Method)

5.3.4.3 The size of a knot on a narrow face is its width between lines enclosing the knot and parallel to the edges of the piece (Fig. 2). A narrow-face knot that appears also in the wide face of a side-cut piece (but does not contain the intersection of those faces) is measured and graded on the wide face.

5.3.4.4 The size of a knot on a wide face is the average of its largest and smallest dimensions (Fig. 2).

5.3.4.5 Any knot that contains the intersection of two faces, including a knot extending entirely across the width of a face in a side-cut piece, is a corner knot. A corner knot is measured on its end between lines parallel to the edges of the piece and is graded with respect to the face on which it is measured (Fig. 2). A corner knot in a piece containing the pith is measured either by its width on the narrow face between lines parallel to the edge, or by its smallest diameter on the wide face, whichever is more restrictive (Fig. 2). If a corner knot appears also on an opposite face, its limitation there as well as on the corner is necessary.

5.3.4.6 The sum of the sizes of all knots in any 6 in. (152 mm) of length of piece shall not exceed twice the size of the largest permitted knot. Two or more knots of maximum or near maximum permissible size shall not be allowed in the same 6 in. (152 mm) of length on a face. Any combination of knots

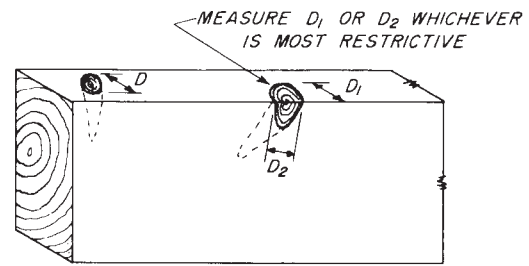

BOXED HEART

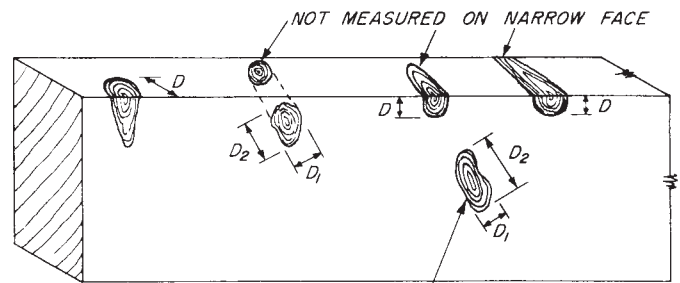

SIDE CUT

FIG. 2 Measurement of Knots in Dimension Lumber Using Alternative Method

that, in the judgment of the lumber grader, will make the piece unfit for its intended use, shall not be admitted.

5.3.4.7 For sizes 3 by 3 in. nominal and smaller the effects of grain distortion associated with knots can be so severe that all knots shall be limited as if they were wide-face edge knots in the face on which they appear.

5.3.4.8 Where the grade is intended to be used for single-span bending applications only, the sizes of knots on narrow faces and at the edge of wide faces may increase proportionately from the size permitted in the middle one third of the length to twice that size at the ends of the piece, except that the size of no knot shall exceed the size permitted at the center of the wide face. The size of knots on wide faces may be increased proportionately from the size permitted at the edge to the size permitted at the centerline (Fig. 3).

5.3.4.9 Where the grade is intended to be used on continuous spans, the restrictions for knots in the middle one third of their lengths shall be applied to the middle two thirds of the length of pieces continuous on three supports, and to the full length of pieces continuous on four or more supports.

5.3.5 Knots in Beams and Stringers:

5.3.5.1 The size of a knot on a narrow face of a beam or stringer is its width between lines enclosing the knot and parallel to the edges of the piece (Fig. 4). When a knot on a narrow face of a side-cut piece extends into the adjacent one fourth of the width of a wide face, it is measured on the wide face.

5.3.5.2 The size of a knot on the wide face is measured by its smallest diameter (Fig. 4). An edge knot on the wide face is limited to the same size as a knot on the narrow face.

5.3.5.3 A corner knot in a beam or stringer containing the pith is measured either by its width on the narrow face between

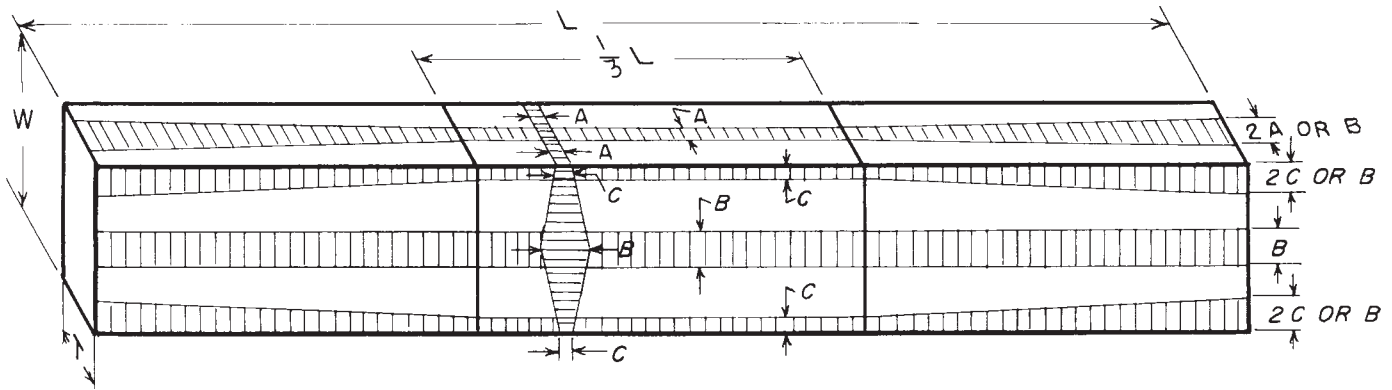

A, maximum size on narrow face in middle third of length with a uniform increase to 2A but not to exceed B, at the ends.
 B, maximum size at center of wide face.
 C, maximum size at edge of wide face in middle third of length with a uniform increase to 2C but not to exceed B at the ends and a uniform increase to B at the center of the wide face. In beams and stringers, A and C are equal.
 L, length.
 W, width of wide face.
 T, width of narrow face.

FIG. 3 Maximum Size of Knots Permitted in Various Parts of Joists and Planks, and Beams and Stringers

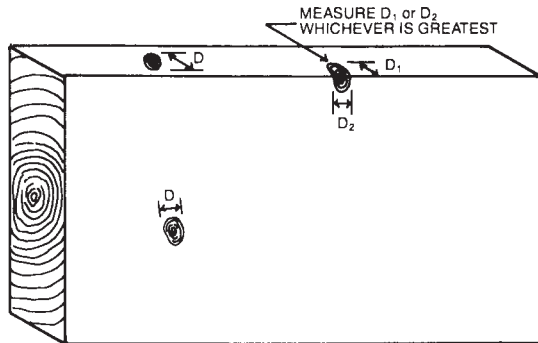

FIG. 4 Measurement of Knots in Beams and Stringers

lines parallel to the edges or by its smallest diameter on the wide face, whichever is greater (Fig. 4). A corner knot in a side-cut piece is measured by whichever of these two is least.

5.3.5.4 The sum of the sizes of all knots within the middle one half of the length of a face, in a beam 20 ft (61 m) or less in length, when measured as specified for the face under consideration, shall not exceed four times the size of the largest knot allowed on that face. This restriction in a beam longer than 20 ft (61 m) shall apply to any 10 ft (30 m) of length within the middle one half of the length.

5.3.5.5 Where the grade is used for single-span bending applications only, the sizes of knots on narrow faces and at the edges of wide faces may be increased proportionately from the size permitted in the middle one third of the length to twice that size at the ends of the piece, except that the size of no knot shall exceed the size permitted at the center of the wide face. The size of knots on wide faces may be increased proportionately from the size permitted at the edge to the size permitted at the center line (Fig. 3).

5.3.5.6 Where the grade is intended to be used on continuous spans, the restrictions for knots in the middle one third of their lengths shall be applied to the middle two thirds of the length of pieces continuous on three supports, and to the full length of pieces continuous on four or more supports.

5.3.6 Knots in Posts and Timbers:

5.3.6.1 The size of a knot on any face of a post or timber is taken as the diameter of a round knot, the lesser of the two diameters of an oval knot, or the greatest diameter perpendicular to the length of a spike knot (Fig. 5).

5.3.6.2 A corner knot is measured wherever the measurement will represent the true diameter of the branch causing the knot.

5.3.6.3 The sum of the sizes of all knots in any 6 in. of length of a post or timber shall not exceed twice the size of the largest permitted knot. Two or more knots of maximum or near maximum permissible size shall not be allowed in the same 6 in. of length on a face.

5.3.6.4 In compression members with greater width than thickness, the sizes of knots in both the narrow and the wide faces are allowed up to the size permitted in the wide face.

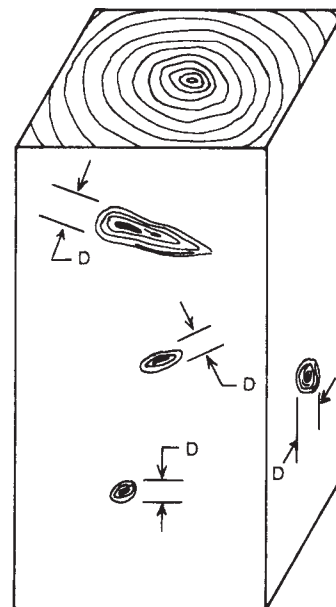

FIG. 5 Measurement of Knots in Posts and Timbers or Other Compression Members

5.3.7 Knots in Stress-Rated Boards:

5.3.7.1 Knots in stress-rated nominal boards are measured by the average of the widths on the two opposite faces, each width being taken between lines parallel to the edges of the board. Knots are not measured on the narrow face, since they appear also in one or both wide faces.

5.3.7.2 The sum of the sizes of all knots in any 6 in. of length shall not exceed twice the size of the largest permitted knot. Two or more knots of maximum permissible size shall not be allowed in the same 6 in. of length on a face.

5.4 Shakes, Checks, and Splits:

5.4.1 Shakes are measured at the ends of the piece. The size of a shake is the distance between lines enclosing the shake and parallel to the wide face of the piece.

5.4.2 Splits and checks are treated as “equivalent shakes,” but are measured differently. The size of a side check is its average depth of penetration into the piece, measured from and perpendicular to the surface of the wide face on which it appears. The size of an end split or end check is one third of its average length measured along the length of a piece, except as noted in 5.4.6.

5.4.3 In single-span bending members, shakes, checks, and splits are restricted only for a distance from each end equal to three times the width of the wide face, and within the critical zone, only in the middle one half of the wide face. For multiple-span bending members, shakes, checks, and splits are restricted throughout the length in the middle one half of the wide face.

5.4.4 Outside the critical zone in bending members, and in axially loaded members, shakes, checks, and splits have little or no effect on strength properties and are not restricted for that reason. It may be advisable to limit them in some applications for appearance purposes, or to prevent moisture entry and subsequent decay.

5.4.5 The grading of any combination of shakes, checks, and splits is based on the grader’s judgment of the probable effects of seasoning or loading in service on the combination. Where a combination of two checks in opposite faces, a check and a split, a check and a shake, or a split and a shake may later become a single horizontal shear plane, the sum of the sizes in the combination is restricted to the allowable size of shakes. Where such a combination is not additive in this way, only the largest single characteristic is considered.

5.4.6 Where 2-in. nominal dimension (See Terminology D 9) is to be used in light building construction in which the shear stress is not critical, a more liberal provision on end splits may be made. The size of the split, measured differently than in 5.4.2, is its average length along the length of the piece.

5.4.7 Provisions for shakes, checks, and splits as described in 5.4.1-5.4.6 are applicable to boards if used where shear strength is important.

5.5 Wane is permissible in all grades of bending members as far as strength properties are concerned, but “free from wane” may be specified when required by appearance, connections, bearing, or other factors of use.

5.6 Specific Gravity Selection:

5.6.1 Lumber may be selected as dense by grain characteristics for Douglas-fir and southern pine. To be classified dense

the wood shall average on one end or the other of each piece not less than six annual rings per inch (25 mm) and one third or more summerwood (the darker, harder portion of the annual ring) measured on a representative radial line. Pieces that average not less than four annual rings per inch (25 mm) shall be accepted as dense if they average one half or more summerwood. The contrast in color between springwood and summerwood in either case shall be distinct.

5.6.1.1 To ensure a representative radial line, measurement shall be made over a continuous length of 3 in. (76 mm) or as nearly 3 in. (76 mm) as is available. The length shall be centrally located in side-cut pieces. In pieces containing the pith, the measurement may exclude an inner portion of the radius amounting to approximately one quarter of the least dimension of the piece.

5.6.2 Dense material of any species may be selected by methods other than described above, provided that such methods ensure the increases in properties given in 4.2.6.

5.6.2.1 One test that may be used to determine whether the requirements of 5.6.2 are met relative to strength properties is to show that:

$$1.17 EV \leq (A + BG) - 1.645 \sqrt{B^2(s^2) + \text{rms}} \quad (1)$$

where:

EV = 5 % exclusion value of a strength property for the species, as described in Test Methods D 2555.

A and *B* = regression coefficients of strength property versus specific gravity for the species given in Table 7,

G = average specific gravity (based on green volume and oven-dry weight) of the pieces selected as dense by mechanical means,

s = the standard deviation of specific gravity of the pieces selected as dense by mechanical means, and

rms = residual mean square (the square of the standard deviation about regression given in Table 7) associated with the regression for strength property versus specific gravity for the species.

5.6.2.2 One test that may be used to determine whether the requirements of 5.6.2 are met relative to modulus of elasticity is to show that:

$$1.05 \bar{Y} \leq A + BG \quad (2)$$

where:

\bar{Y} = average modulus of elasticity of the species, as given in Test Methods D 2555,

A and *B* = regression coefficients of modulus of elasticity versus specific gravity for the species given in Table 9, and

G = average specific gravity (based on green volume and oven-dry weight) of the pieces selected as dense by mechanical means.

5.6.3 Lumber may be selected as close grain for Douglas-fir from the Coast Region, redwood, and southern pine. To be classified as close grain the wood shall average on one end or the other of each piece not less than 6 nor more than 30 annual rings per inch (25 mm) measured on a representative radial

TABLE 7 Regression Coefficients for Strength Properties Versus Specific Gravity

NOTE 1—These coefficients are extracted from Refs (6) and (7).

| Species or Region or Both | Properties | | | | | | | | | | | | | | |
|---------------------------|--------------------|----------------|---|-----------------------|----------------|---|---|----------------|---|----------------|----------------|---|------------------------------------|----------------|---|
| | Modulus of Rupture | | | Modulus of Elasticity | | | Compression Parallel to Grain, max crushing | | | Shear | | | Compression Perpendicular to Grain | | |
| | A ^A | B ^A | Standard Deviation from Regression ^B | A ^A | B ^A | Standard Deviation from Regression ^B | A ^A | B ^A | Standard Deviation from Regression ^B | A ^A | B ^A | Standard Deviation from Regression ^B | A ^A | B ^A | Standard Deviation from Regression ^B |
| Douglas-fir | | | | | | | | | | | | | | | |
| Coast | -1757 | 20 894 | 572 | -259 | 4036 | 216 | -1087 | 10 803 | 403 | 193 | 1580 | 96 | ... | ... | ... |
| Interior west | -1750 | 20 694 | 571 | -408 | 4203 | 215 | -1548 | 11 854 | 414 | 174 | 1669 | 98 | ... | ... | ... |
| Interior north | -1396 | 19 783 | 635 | -212 | 3631 | 208 | -905 | 9797 | 360 | 184 | 1711 | 94 | ... | ... | ... |
| Interior south | 25 | 15 679 | 576 | 151 | 2346 | 171 | 21 | 7174 | 369 | 18 | 2171 | 118 | ... | ... | ... |
| White fir | -277 | 16 650 | 588 | -226 | 3770 | 183 | -854 | 10 200 | 265 | 306 | 1223 | 56 | ... | ... | ... |
| Cal. red fir | 57 | 15 993 | 562 | 179 | 2759 | 240 | -267 | 8411 | 286 | 287 | 1336 | 134 | ... | ... | ... |
| Grand fir | 2516 | 9591 | 538 | 697 | 1650 | 148 | 991 | 5623 | 269 | 218 | 1505 | 72 | ... | ... | ... |
| Pacific silver fir | -1861 | 21 086 | 447 | 109 | 3343 | 169 | -568 | 9459 | 227 | 70 | 1725 | 56 | ... | ... | ... |
| Noble fir | -1148 | 19 518 | 487 | -588 | 5253 | 214 | -1285 | 11 467 | 272 | 275 | 1408 | 122 | ... | ... | ... |
| Western hemlock | -365 | 16 623 | 637 | 214 | 2597 | 218 | -764 | 9804 | 329 | 221 | 1529 | 67 | ... | ... | ... |
| Western larch | 1004 | 13 905 | 742 | 726 | 1534 | 237 | -31 | 7921 | 414 | 294 | 1204 | 61 | ... | ... | ... |
| Black cottonwood | 352 | 14 269 | 815 | 263 | 2580 | 176 | 484 | 5396 | 308 | 52 | 1761 | 69 | ... | ... | ... |
| Southern Pine | | | | | | | | | | | | | | | |
| Loblolly | -1318 | 18 287 | 717 | -317 | 3648 | 258 | -967 | 9501 | 354 | 224 | 1359 | 86 | -150 | 1191 | 98 |
| Longleaf | -986 | 17 609 | 811 | -281 | 3453 | 216 | -466 | 8851 | 485 | 298 | 1365 | 91 | -135 | 1124 | 133 |
| Shortleaf | 67 | 15 682 | 851 | 227 | 2472 | 237 | -300 | 8141 | 383 | -34 | 1999 | 73 | 24 | 644 | 101 |
| Slash | 47 | 16 152 | 551 | 198 | 2492 | 252 | 778 | 5690 | 423 | 391 | 1070 | 110 | 57 | 874 | 143 |

^ACoefficients in the relation $Y = A + BX$ where Y = mechanical property (in 1000 psi for MOE; in psi for all others) and X = specific gravity.

^BThe standard deviation from regression is a measure of dispersion about the regression, representing the standard deviation of property about the line at any choice of specific gravity. This parameter is often called the standard error of estimate. Units are in psi except MOE, which is in 1000 psi.

line. To ensure a representative radial line, measurement shall be made as in 5.6.1.1. Pieces averaging at least 5 or more than 30 rings per inch shall be accepted as close-grained if the measurement shows one third or more summerwood. Visually selected close-grained redwood shall average in one piece not less than 8 nor more than 40 annual rings per inch.

5.6.4 Close-grained wood of any species may be selected by methods other than described above, provided that such methods ensure the increases in properties given in 4.2.6.

5.6.4.1 One test that may be used to determine whether the requirements of 5.6.4 are met is to show that:

$$1.07 EV \leq (A + BG) - 1.645 \sqrt{B^2(s^2) + r_{ms}} \quad (3)$$

where the symbols have the meaning given in 5.6.2.1.

5.6.5 It is advisable to reject exceptionally lightweight pieces from the highest grades. For the softwoods with pronounced summerwood, selection for medium grain serves this purpose. Medium-grained wood shall average on one end or the other of each piece not less than four annual rings per inch (25 mm), measured on a representative radial line. To ensure a representative radial line, measurement shall be made as in 5.6.1.1.

6. Allowable Properties for Timber Design

6.1 *Principles of Determination of Allowable Properties*—Test Methods D 2555 provide information on clear wood property values and their variation. From these values, allowable properties are obtained for green lumber, according to the permitted growth characteristics as discussed in Sections 4 and 5. The allowable properties are based on normal loading duration, and the assumption that design loads are realistic and that each member carries its own load. Allowable properties can be determined for individual species or groups of species. The allowable modulus of elasticity and compression perpendicular-to-grain stress are intended to be average values for the species group and stress grade; the other allowable stresses are intended to be less than the stress permissible for 95 % of the pieces in a species group and stress grade. In other words, most allowable stresses are based on the concept of a 5 % exclusion limit.

6.1.1 Allowable property values shall be rounded to the nearest value having increments as shown below, after all adjustments in the allowable properties have been made.

| | | |
|---|---|---|
| Bending Tension parallel to grain Compression parallel to grain | } | { nearest 50 psi (340 kPa) for allowable stress of 1000 psi (6.9 MPa) or greater nearest 25 psi (170 kPa) otherwise |
| Horizontal shear Compression perpendicular to grain | } | { nearest 5 psi (34 kPa) |
| Modulus of elasticity | | nearest 100 000 psi (69 GPa) |

The rounding rules of Practice E 380, 4.2, shall be followed.

6.2 The 5 % exclusion limit for bending strength, tensile strength parallel to grain, compressive strength parallel to grain, and horizontal shear strength for clear straight-grained wood in the green condition shall be obtained for any species or group of species from Test Methods D 2555. These properties when divided by the factors given in Table 8 give the

TABLE 8 Adjustment Factors to Be Applied to the Clear Wood Properties

| | Bending Strength | Modulus of Elasticity in Bending | Tensile Strength Parallel to Grain | Compressive Strength Parallel to Grain | Horizontal Shear Strength | Proportional Limit and Stress at Deformation in Compression Perpendicular to Grain |
|-----------|------------------|----------------------------------|------------------------------------|--|---------------------------|--|
| Softwoods | 2.1 | 0.94 | 2.1 | 1.9 | 2.1 | 1.67 |
| Hardwoods | 2.3 | 0.94 | 2.3 | 2.1 | 2.3 | 1.67 |

respective allowable design properties for clear straight-grained wood. The factors include an adjustment for normal duration of load and a factor of safety.

6.2.1 The average green modulus of elasticity, proportional limit in compression perpendicular to grain, and stress in compression perpendicular to grain at 0.04-in. (1-mm) deformation shall be obtained for any species or group of species from Test Methods D 2555. The properties shall be divided by the factors given in Table 8. The factor for modulus of elasticity adjusts the modulus from a span-depth ratio of 14 to a span-depth ratio of 21 and an assumed uniform loading. The factor for the proportional limit stress in compression perpendicular to grain and for stress in compression perpendicular to grain at a deformation is an adjustment for the most limiting ring position (8).

6.2.2 As an alternative to 6.2.1, the modulus of elasticity of lumber grades may be determined by a comprehensive survey of material in the finished condition of manufacture. The objective of a survey is to measure with acceptable precision the average modulus of any grade or classification of lumber, and should also provide detail on the variability of the modulus. Appropriate correlations for orientation in use and span-depth ratios shall be applied to the survey data. The survey shall be representative of the entire output of the grade for any species or commercial species group. Sampling should conform to the requirements of Practice E 105. In addition, it should allow for analysis of all significant sources of variation, such as moisture content, density, geographic location, and grade quality. The lumber shall be tested in a fashion sufficient to give a modulus free from measurable shear deflections (see Note 3). At least two increments of load shall be applied, and loads and deflections shall be measured to an accuracy of at least three significant digits. The report of a survey shall demonstrate that the requirements of this paragraph have been met.

NOTE 3—One method of testing 2-in. nominal thickness lumber to give a modulus of elasticity free from measurable shear deflections is to test pieces 8 ft (24.4 m) long or longer flatwise over supports placed 6 in. (152 mm) from the ends, with equal loads placed 18 in. (457 mm) on either side of the center.

6.2.3 Proportional limit stresses in compression perpendicular to the grain apply to bolted and other mechanically fastened wood joints. When compression perpendicular to grain is used

as a measure of bearing deformation, compression perpendicular stress at 0.04-in. (1-mm) deformation is applicable. To adjust for a lower deformation level, the following equation may be used.

$$Y_{02} = 0.73 Y_{04} + 5.60 \quad (4)$$

where:

Y_{02} = mean stress at 0.02-in. (0.5-mm) deformation, and
 Y_{04} = mean stress at 0.04-in. (1-mm) deformation.

6.3 The properties obtained as described in 6.2 shall be further modified according to the permitted characteristics in any stress grade. This is done by multiplying the properties by the appropriate strength ratios, expressed as decimals, from 4.2. These calculations yield allowable properties for each piece of lumber in a stress grade, in the green condition and under an assumed normal duration of load.

7. Modification of Allowable Properties for Design Use

NOTE 4—The principal modifications made in design properties are summarized in Table 9. It is assumed to be the final responsibility of the designing engineer to relate design assumptions and allowable properties, and to make modifications of the allowable properties for seasoning and duration of load to fit a particular use. These modifications are often subject to the requirements of a building code. This section contains some recommended modification criteria.

7.1 Moisture Content:

7.1.1 The strength and stiffness of wood increases as its moisture content decreases below the fiber saturation point, however, for sizes thicker than 4 in. nominal these increases may be offset to varying extent by the shrinkage and seasoning

TABLE 9 Modification of Properties by Grade and Use Factors^{AB}

| Kind of Allowable Stress | Size Classification | Allowable Stress Modified by: | | | | |
|--|-------------------------------|-------------------------------|----------------|---------|-----------|------------------|
| | | Grade | Rate of Growth | Density | Seasoning | Duration of Load |
| 1 | 2 | 3 | 4 | 5 | 6 | 7 |
| Extreme fiber in bending and tension parallel to grain | stress rated dimension lumber | yes | yes | yes | yes | yes |
| | beams and stringers | yes | yes | yes | no | yes |
| | posts and timbers | yes | yes | yes | no | yes |
| Horizontal shear | all sizes | yes | no | no | yes | yes |
| Compression perpendicular to grain | all sizes | no | yes | yes | yes | no ^C |
| Compression parallel to grain | all sizes | yes | yes | yes | yes | yes |
| Modulus of elasticity | all sizes | yes | no | yes | yes | no |

^AModification for grade (column 3) is accomplished by application of the strength ratio. Modifications in the allowable properties for rate of growth and density (columns 4 and 5) are shown in 5.6 for the appropriate species. Modifications for seasoning and duration of load (columns 6 and 7) are to be made by the designer to fit the particular conditions for which the design is made.

^BSee 7.4 for a discussion of possible adjustments of working stress for decay hazard.

^CDuration of load modification applies when calculating proportional limit stress in compression perpendicular to grain.

defects that occur. For these reasons the modifications, shown in Table 10, of allowable properties are applicable to lumber 4 in. nominal or less in thickness when it is at a maximum moisture content of 19 % or 15 % and which will not exceed these maximum moisture contents in use and providing they are related to the net dimensions (see Note 5) at these maximum moisture contents. In addition the increases applicable to 15 % maximum moisture content apply only to lumber when manufactured at 15 % or lower moisture content. The increases for horizontal shear apply only to lumber that is at these maximum moisture contents at the time of manufacture (Note 6). The seasoning adjustments in Table 10 do not apply to lumber that will be above 19 % maximum moisture in use.

NOTE 5—For lumber 4 in. nominal or less in thickness which is surfaced unseasoned, and seasons to 19 % maximum moisture content, the effect of shrinkage may be accounted for by surfacing oversize or by using lesser increases for seasoning in allowable stress in bending, tension parallel to grain, compression parallel to grain and modulus of elasticity.

NOTE 6—A batch of lumber with a maximum moisture content of 19 % is assumed to have an average moisture content of 15 % and a batch of lumber with a maximum moisture content of 15 % is assumed to have an average moisture content of 12 %.

7.1.2 The increases in allowable properties given in Table 10 at 15 % maximum moisture content, when divided by 100 and added to 1, shall not exceed the ratio of dry to green clear wood properties as given in Test Methods D 2555. If the values obtained from Test Methods D 2555 are used at 15 % maximum moisture content, the corresponding values at 19 % maximum moisture content shall be obtained as follows:

$$\text{Percentage increase} = 100K (R_{15} - 1) \quad (5)$$

where:

R_{15} = ratio of dry to green clear wood property as given in Table X1 of Test Methods D 2555,

K = 0.7143 for bending, 0.7000 for modulus of elasticity, 0.7143 for tension parallel to grain, 0.6667 for compression parallel to grain, 1.000 for compression perpendicular to grain, and 0.6154 for horizontal shear.

7.1.3 For sizes thicker than 4 in. nominal, the increase from drying is significant in all grades of compression members. An increase of 10 % above allowable stress values for green lumber based on net size at the time of manufacture for

TABLE 10 Modification of Allowable Stresses for Seasoning Effects for Lumber 4 in. and Less in Nominal Thickness (9)^A

| Property | Percentage Increase in Allowable Property Above That of Green Lumber When Maximum Moisture Content is | |
|------------------------------------|---|-----------------|
| | 19 % | 15 % |
| Bending | 25 | 35 |
| Modulus of elasticity | 14 | 20 |
| Tension parallel to grain | 25 | 35 |
| Compression parallel to grain | 50 | 75 |
| Horizontal shear | 8 | 13 |
| Compression perpendicular to grain | 50 ^A | 50 ^A |

^AThe increase in compression perpendicular to grain is the same for all degrees of seasoning below fiber saturation since the outer fibers which season rapidly have the greatest effect on this strength property regardless of the extent of the seasoning of the inner fibers.

compression members of all lengths may be taken for drying regardless of grade. Care must be taken in applying this increase that the compression member is sufficiently seasoned before full load is applied.

7.1.4 An increase of 2 % in modulus of elasticity based on net size at the time of manufacture may be taken for sizes thicker than 4 in. nominal providing the lumber is seasoned to a substantial depth before full load is applied. Care should be taken in applying this increase that an appreciable seasoning of the outer fibers has taken place before full load is applied.

7.2 Size Factors:

7.2.1 The bending stress obtained from 5.2 is based on an assumed 2-in. (51-mm) depth. To adjust the stress to other sizes, multiply it by the factor, *F*, taken from (10):

$$F = (2/d)^{1.9} \quad (6)$$

where *d* = net surfaced depth. This formula is based on an assumed center load and a span to depth ratio of 14.

7.2.2 Allowable stresses for compression parallel to grain apply to posts, columns, or struts whose length is fully supported against lateral buckling.

7.3 Duration of Load:

7.3.1 Allowable stresses derived by these methods are applicable to the condition of normal loading. Normal load duration contemplates fully stressing a member to the allowable stress by the application of the full maximum design load for a duration of approximately 10 years either continuously or cumulatively or the application of 90 % of this full maximum load continuously throughout the remainder of the life of the structure, or both, without encroaching on the factor of safety.

7.3.2 For other durations of load than normal loading, allowable stresses may be modified using Fig. 6. This figure is supported by studies in bending (11, 12). Limited supporting data suggest the same relationship may be used for the other allowable stresses. However, the curve is not exact, and precise interpretations from it should not be made.

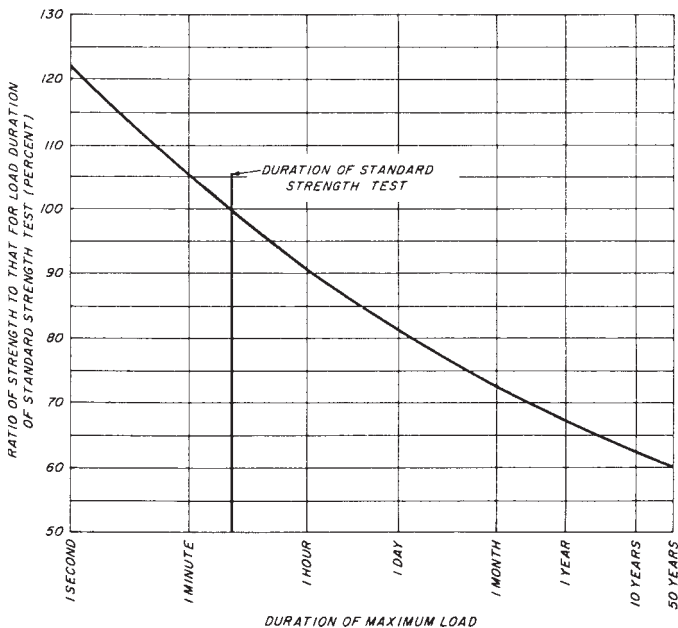

FIG. 6 Relation of Strength to Duration of Load

7.3.3 Modulus of elasticity, when used as a measure of deflection or deformation, does not change with time. When used in calculating safe loads for column buckling, a reduction factor 2.74 shall be applied to the modulus of elasticity value. No adjustment for duration of load shall be made when determining allowable loads for a column limited by buckling.

7.3.4 Wood under continuing load takes on a deformation known as plastic flow, usually very slow but persistent over long periods of time. Deflection of this nature occurring in timbers acting as beams is sometimes known as “set” or “sag.” The allowable stress adjustments in 6.2 and 7.3.2 provide for safe stresses under these circumstances. However, it is necessary, where deformation or deflection under long periods of loading must be limited in amount, to provide extra stiffness. This can be done by doubling any dead or long-time loads when calculating deformation, by setting an initial deformation limit at half the long-time deformation limit, or by using one half of the recommended value of modulus of elasticity in calculating the immediate deformation. In any case, it is to be understood that the recommended values for modulus of elasticity will give the immediate deflection of a beam, and that this will increase under long-continued load. The increase may be somewhat greater where the timber is subjected to varying temperature and moisture conditions than where the conditions are uniform.

7.3.5 A study of the continuing increase of deformation may be used to evaluate the safety of heavily stressed timbers. A deformation continuing to increase, but at a decreasing rate, even after a very long period of time, does not presage failure. On the other hand, deformation continuing to increase at a uniform rate may be a danger signal, and when the increase begins to accelerate, failure is imminent.

7.3.6 Allowable stress values may be increased 100 % for occasional impact, provided that the resulting sizes of structural members are safe also for any static loads on the structure.

7.3.7 Where stress in compression perpendicular to grain at 0.04 in. (1 mm) or other deformation level is used as a measure of bearing deformation, such stresses shall not be modified for duration of load.

7.4 Aging—Normal aging effects in old timbers may include seasoning, weathering, or chemical change, in addition to the effect from duration of load. In the absence of deteriorating influences such as decay, these additional aging effects are structurally unimportant. Strength tests of old timbers from a number of sources have shown that wood does not deteriorate appreciably in strength or stiffness from age alone for periods of 100 years or more. Old lumber may be appraised with respect to its species, grade, and condition. Where the condition is good, and no evidence of decay or other specific deteriorating influence appears, old lumber may be given the same working stress values as those for new lumber of equivalent species and grade.

7.5 Decay:

7.5.1 Since there is no satisfactory way of numerically appraising the effect of decay on the strength of wood, decay is excluded from most structural grades. No allowable stress can be assigned with assurance to timber containing decay. Decay confined to knots and not present in wood surrounding them

may be permitted in some structural grades. Limited decay of pocket-type may be permitted in the lower dimension grades. Structural lumber exposed to the hazard of decay should be inspected at frequent and regular intervals. If decay is detected in or near highly stressed areas, the member should be replaced. Special attention given to such features as drainage and ventilation will help reduce or eliminate the necessity of removing lumber because of decay. Treated wood or the heartwood of species of high natural decay resistance should be used to prolong the life and eliminate the need for expensive replacements wherever conditions are favorable to decay.

7.6 *Treated Wood:*

7.6.1 It may be necessary in establishing allowable working stresses for preservative treated timber to take into account possible reductions in strength that may result from the high temperatures and pressures used for conditioning of wood at a high moisture content under approved methods of treatment. Results of tests of treated timber show reduction in stress in extreme fiber in bending and in compression perpendicular to grain ranging from a few percent up to 25 %, depending on the treating conditions. Compression parallel to grain is affected less and the modulus of elasticity very little. The effect on resistance to horizontal shear can be estimated by inspection for shakes and checks after treatment. Incising to increase retention of treatment may have an adverse effect on strength.

7.6.2 These reductions in strength can be minimized by restricting temperatures, heating periods, and pressures as much as is consistent in obtaining the absorption and penetration required for proper treatment.

7.6.3 Where structural design with treated timbers is on a conservative basis, any initial loss of strength from treatment is balanced against the progressive loss of strength of untreated wood with the incidence of decay.

7.7 *Temperature*—Allowable properties are applicable to lumber used under ordinary ranges of temperature. Occasional exposures up to about 150°F (65.6°C) and longer exposures up to about 125°F (51.7°C) are provided for. Special allowance should be made for lumber subjected to abnormally high temperature, particularly for long periods of time.

7.8 *Bearing Areas*—Allowable stresses are unit values that generally do not vary with the area loaded. In compression perpendicular to grain, however, there is a supporting action of fibers adjoining the loaded area that has the effect of increasing allowable unit stresses on small bearing areas. The values for compression perpendicular to grain apply to bearings 6 in. (152 mm) or more in length located anywhere in the length of a structural member and to bearings of any length located at the ends of beams or joists. For bearings shorter than 6 in. (152 mm) or for round bearing areas (as under washers) of the same diameters, if located 3 in. (76 mm) or more from the end of a member, the stresses may be increased in accordance with the following factors:

| Length of Diameter of Bearing Area, in. | Adjustment Factor |
|---|-------------------|
| 1/2 | 1.75 |
| 1 | 1.38 |
| 1 1/2 | 1.25 |
| 2 | 1.19 |
| 3 | 1.13 |
| 4 | 1.10 |

6 or more

1.00

7.9 *Multiple-Member Systems:*

7.9.1 In many constructions, three or more load-carrying members such as joists, rafters, studs, or decking are contiguous or are spaced not more than 24 in. in frame construction and are joined by transverse floor, roof, or other load distributing element. Tests demonstrate that the interaction of such assemblies provides load-carrying capacity and stiffness of the assembly that are greater than the capacity predicted by these methods for the sum of the individual members. An increase in bending stress of 15 % for members used in such systems is therefore recommended as a design consideration.

7.9.2 A transverse distributing element is considered to be any adequate system that is designed or has been proven by experience to transmit the design load to adjacent members spaced as described in 7.9.1 without displaying structural weakness of unacceptable deflection. Subflooring, flooring, sheathing, or other covering elements and nail gluing or tongue and groove joints, and through nailing generally meet these criteria.

8. **Example of Stress-Grade Development**

8.1 This example is for dimension lumber for light building construction 1 1/2 in. (38 mm) thick and 5 1/2 in. (140 mm) wide, at 19 % maximum moisture content, and of a fictitious softwood species. It is desired to achieve a strength ratio in bending of 60 %, in compression parallel to grain of 65 %, and in shear of 50 %. It is desired to calculate compression perpendicular to grain both as proportional limit and as stress at a deformation.

8.1.1 Table 11 gives the limiting characteristics that will provide these strength ratios. Based on the tabulated values, the limiting provisions for this grade and size are:

- 8.1.1.1 Slope of grain no more than 1 in 10,
- 8.1.1.2 Knots on narrow face no larger than 3/4 in. (19 mm),
- 8.1.1.3 Knots at centerline of wide face no larger than 2 1/2 in. (29 mm),
- 8.1.1.4 Knots at edge of wide face no larger than 1 3/8 in. (35 mm),
- 8.1.1.5 Sizes of shakes and checks set independently of strength ratio.

TABLE 11 Example of Selection of Limiting Characteristics

| Property | Limiting Characteristic | Strength | |
|--|---|----------|------------|
| | | Ratio, % | From Table |
| Bending | narrow face knot = 3/4 in. (19 mm) | 62 | 2 |
| | knot on centerline of wide face = 2 3/8 in. (60 mm) | 60 | 3 |
| | knot at edge of wide face = 1 3/8 in. (35 mm) | 60 | 4 |
| | slope of grain 1 in 10 | 61 | 1 |
| Compression strength parallel to grain | knot on any face = 2 1/8 in. (54 mm) | 65 | 3 |
| | slope of grain 1 in 8 | 66 | 1 |
| Shear | size of shake or check = 1/2 in. (13 mm) | 50 | |
| | length of end split = 4 1/8 in. (105 mm) | 50 | |

TABLE 12 Allowable Properties for the Sample Stress-Grade

| Property in | Clear Wood Strength Value, psi (kPa) | Adjustment Factor | Strength Ratio ÷ 100 | Seasoning Adjustment | Special Factors | Allowable Property, ^A psi (kPa) |
|--|--------------------------------------|-------------------|----------------------|----------------------|-----------------|--|
| Bending | 4 432 (30 560) | 1/2.1 | 0.60 | 1.25 | 0.89 | 1 400 (9 310) |
| Compression parallel to grain | 2 174 (14 999) | 1/1.9 | 0.65 | 1.50 | | 1 100 (7 580) |
| Horizontal shear | 576 (3 970) | 1/2.1 | 0.50 | 1.08 | | 150 (1020) |
| Tension parallel to grain | 4 432 (30 560) | 1/2.1 | 0.60 × 0.55 | 1.25 | | 850 (5 860) |
| Modulus of elasticity | 1 304 000 (8 991 080) | 1/0.94 | 1.00 | 1.14 | | 1 580 000 (10 894 100) |
| Compression perpendicular ^B | 282 (1 940) | 1/1.67 | 1.00 | 1.50 | | 255 (1 745) |
| perpendicular ^C | 491 (3 390) | 1/1.67 | 1.00 | 1.50 | | 440 (3 040) |

^AObtained by multiplying together the 5 preceding columns.
^BCompression perpendicular to grain for proportional limit stress.
^CCompression perpendicular to grain at 0.04 in. (1 mm) deformation.

8.1.2 For this grade, a complete complement of allowable properties have been developed, and are given in Table 12.

9. Keywords

9.1 lumber; solid sawn structural lumber; structural grades; visually graded; wood

APPENDIX

(Nonmandatory Information)

X1. FORMULAS FOR DETERMINING STRENGTH RATIOS CORRESPONDING TO VARIOUS KNOT SIZES AND WIDTH OF FACE FOR BEAMS AND STRINGERS, DIMENSION LUMBER AND POSTS AND TIMBERS

NOTE X1.1—The strength ratios given in Table 2, Table 3, and Table 4 have been computed using the formulas given herein.

In the following formulas:

- b* = actual narrow face width, in.,
- h* = actual wide face width, in.,
- k* = knot size, in.,
- w* = check width, in.,
- l* = split length, and
- S* = strength ratio, %

X1.1 Formulas for Strength Ratios Corresponding to Various Combinations of Size of Knot and Width of Narrow Face

NOTE X1.2—These formulas cover bending members with knots on narrow face within middle one third of length of piece. Strength ratios are for stress in extreme fiber in bending.

| Limitations | Formula |
|--|---|
| <i>S</i> ≥ 45 %; <i>b</i> ≥ 6 in. (152 mm) | $S = 100 \left[1 - \frac{k - (1/24)}{\sqrt{6(b + (1/2))}} \right]$ |
| <i>S</i> ≥ 45 %; <i>b</i> < 6 in. (152 mm) | $S = 100 \left[1 - \frac{k - (1/24)}{b + (3/8)} \right]$ |
| <i>S</i> < 45 % | $S = 100 \left[1 - \frac{k - (1/24)}{b} \right]$ |

X1.2 Formulas for Strength Ratios Corresponding to Various Combinations of Size of Knot and Width of Wide Face

NOTE X1.3—These formulas cover:
 (I) Bending members with knots along the center line of wide face at

any point in the length of the piece. Strength ratios are for stress in extreme fiber in bending.

(2) Compression with knots at any point on any face. Strength ratios are for stress in compression parallel to grain.

| Limitations | Formula |
|---|--|
| <i>S</i> ≥ 45 %; | |
| 6 in. (152 mm) ≤ <i>h</i> ≤ 12 in. (305 mm) | $S = 100 \left[1 - \frac{k - (1/24)}{h + (1/2)} \right]$ |
| <i>S</i> ≥ 45 %; <i>h</i> < 6 in. (152 mm) | $S = 100 \left[1 - \frac{k - (1/24)}{h + (3/8)} \right]$ |
| <i>S</i> ≥ 45 %; <i>h</i> > 12 in. (305 mm) | $S = 100 \left[1 - \frac{k - (1/24)}{\sqrt{12(h + (1/2))}} \right]$ |
| <i>S</i> < 45 %; <i>h</i> ≤ 12 in. (305 mm) | $S = 100 \left[1 - \frac{k - (1/24)}{h} \right]$ |
| <i>S</i> < 45 %; <i>h</i> > 12 in. (305 mm) | $S = 100 \left[1 - \frac{k - (1/24)}{\sqrt{12h}} \right]$ |

X1.3 Formulas for Strength Ratios Corresponding to Various Combinations of Size of Knot and Width of Wide Face

NOTE X1.4—These formulas cover bending members with knots at edge of wide face within middle one third of length of piece. Strength ratios are for stress in extreme fiber in bending.

| Limitations | Formula |
|---|---|
| <i>S</i> ≥ 45 %; | |
| 6 in. (152 mm) ≤ <i>h</i> ≤ 12 in. (305 mm) | $S = 100 \left[1 - \frac{k - (1/24)}{h + (1/2)} \right]^2$ |
| <i>S</i> ≥ 45 %; <i>h</i> < 6 in. (152 mm) | $S = 100 \left[1 - \frac{k - (1/24)}{h + (3/8)} \right]^2$ |

Limitations

 $S \geq 45\% ; h > 12 \text{ in. (305 mm)}$

Formula

$$S = 100 \left[1 - \frac{k - (1/24)}{\sqrt{12(h + (1/2))}} \right]^2$$

Limitations

 $S < 45\% ; h \leq 12 \text{ in. (305 mm)}$
 $S < 45\% ; h > 12 \text{ in. (305 mm)}$

$$S = 100 \left[1 - \frac{k - (1/24)}{\sqrt{12h}} \right]^2$$

REFERENCES

- (1) Forest Products Laboratory, "Wood Handbook: Wood as an Engineering Material," *Agriculture Handbook 72*, Washington, DC: U.S. Department of Agriculture; rev. 1987.
- (2) Wilson, T. R. C., "Guide to the Grading of Structural Timbers," *Miscellaneous Publication 185*, XAMPA, U.S. Department of Agriculture, 1934.
- (3) Wilson, T. R. C., "Effect of Spiral Grain on the Strength of Wood," *Journal of Forestry*, JFUSA, Vol XIX, No. 7, 1921, pp. 1–8.
- (4) Doyle, D. V., and Markwardt, L. J., "Tension Parallel-to-Grain Properties of Southern Pine Dimension Lumber," *Research Paper FPL 84*, XAFLA, U.S. Forest Products Laboratory, 1967.
- (5) Wood, L. W., "Strength Grading by Rules for Density and Close Grain," *Report No. 1797*, XAFRA, U.S. Forest Products Laboratory, 1951.
- (6) "Western Wood Density Survey; Report No. 1," Research Paper FPL 27, U.S. Forest Products Laboratory, 1965.
- (7) "Properties of Major Southern Pines: Part I– Wood Density Survey, Part II – Structural Properties and Specific Gravity," Research Paper FPL 176–177, Revised 1975, U.S. Forest Products Laboratory, 1975.
- (8) Bendtsen, B. A. and Galligan, W. L., "Modeling the Stress-Compression Relationships in Wood in Compression Perpendicular to Grain," *Forest Products Journal*, Vol 29, No. 2, 1979, pp. 42–48.
- (9) Green, David W., Evan, James W., "Evolution of Standardized Procedures for Adjusting Lumber Properties for Change in Moisture Content," Gen. Tech. Rep. FPL-GTR-127, U.S. Department of Agriculture, Forest Service; Forest Products Laboratory, Madison, WI, 2001, 50 pp.
- (10) Bohannan, B., "Effect of Size on Bending Strength of Wood Members," *Research Paper FPL 56*, XAFLA, U.S. Forest Products Laboratory, 1966.
- (11) Keeton, J. R., "Dynamic Properties of Small Clear Specimens of Structural Grade Timber," *Technical Report R573*, California Naval Civil Engr. Laboratory, 1968.
- (12) Wood, L. W., "Relation of Strength of Wood to Duration of Load," *Report No. 1916*, XAFRA, U.S. Forest Products Laboratory, 1951.

ASTM International takes no position respecting the validity of any patent rights asserted in connection with any item mentioned in this standard. Users of this standard are expressly advised that determination of the validity of any such patent rights, and the risk of infringement of such rights, are entirely their own responsibility.

This standard is subject to revision at any time by the responsible technical committee and must be reviewed every five years and if not revised, either reapproved or withdrawn. Your comments are invited either for revision of this standard or for additional standards and should be addressed to ASTM International Headquarters. Your comments will receive careful consideration at a meeting of the responsible technical committee, which you may attend. If you feel that your comments have not received a fair hearing you should make your views known to the ASTM Committee on Standards, at the address shown below.

This standard is copyrighted by ASTM International, 100 Barr Harbor Drive, PO Box C700, West Conshohocken, PA 19428-2959, United States. Individual reprints (single or multiple copies) of this standard may be obtained by contacting ASTM at the above address or at 610-832-9585 (phone), 610-832-9555 (fax), or service@astm.org (e-mail); or through the ASTM website (www.astm.org).