



Standard Test Method for Fungicides for Controlling Sapstain and Mold on Unseasoned Lumber (Laboratory Method)¹

This standard is issued under the fixed designation D 4445; the number immediately following the designation indicates the year of original adoption or, in the case of revision, the year of last revision. A number in parentheses indicates the year of last reapproval. A superscript epsilon (ε) indicates an editorial change since the last revision or reapproval.

1. Scope

1.1 This (laboratory) method is used for determining the minimum concentration of fungicide, or formulation of fungicides, that is effective in preventing biodeterioration by sapstain fungi and molds in selected species of wood under optimum laboratory conditions.

NOTE 1—From the results of this test, commercial treating solution concentrations cannot be estimated without further field tests.

1.2 The requirements for test materials and procedures are discussed in the following order:

	Section
Summary of Method	3
Apparatus	5
Reagents	6
Wood	7
Test Fungi	8
Culture Media	9
Preparation of Inoculum	10
Preparation of Test Chambers	11
Treatment of Samples	12
Inoculation and Incubation	13
Evaluation of the Test	14
Report	15

1.3 *This standard does not purport to address all of the safety concerns, if any, associated with its use. It is the responsibility of the user of this standard to establish appropriate safety and health practices and determine the applicability of regulatory limitations prior to use.*

2. Referenced Documents

- 2.1 *ASTM Standards:*
- D 1193 Specification for Reagent Water²

3. Summary of Method

3.1 Unseasoned sapwood specimens are treated either by spraying with, or by immersing in, solutions or dispersions of a fungicide formulation prepared at five or more concentration levels. The specimens are exposed to sapstain fungi and molds.

¹ This method is under the jurisdiction of ASTM Committee D07 on Wood and is the direct responsibility of Subcommittee D07.06 on Treatments for Wood Products.

Current edition approved April 10, 2003. Published June 2003. Originally approved in 1984. Last previous edition approved in 1991 as D 4445 – 91(1996)¹.

² *Annual Book of ASTM Standards*, Vol 11.01.

The toxicity of fungicides may be tested against individual fungi, in which case sterilization of the samples is necessary, or against several fungi by using a mixed spore suspension for the inoculation of the specimens; in the latter case, sterilization is unnecessary.

3.2 The intensity of surface fungal growth is estimated after incubation and the results used to determine the chemical treatment concentration giving zero growth (CGo).

4. Significance and Use

4.1 This method is useful as a screening procedure for selecting fungicides or formulations for more rigorous field evaluation.

5. Apparatus

5.1 *Incubation Room (or Incubation Cabinet)*, maintained at a temperature of 25 ± 1°C, and relative humidity between 70 and 80 %.

5.2 *Steam Sterilizer.*

5.3 *Containers:*

5.3.1 *Petri Dishes*, with minimum size of 100 (diameter) by 20 mm (height) with lid or,

5.3.2 *Aluminum Pans*, with minimum size of 240 by 100 by 20 mm (height) with aluminum foil cover.

6. Reagents

6.1 *Purity of Water*—Reference to water shall be understood to mean sterile reagent water conforming to Type IV of Specification D 1193.

7. Wood

7.1 *General Properties*—The wood species to be tested should be locally available commercial species selected on the basis of their susceptibility to staining fungi (pine or spruce species are preferred). Sapwood of the selected wood species, unseasoned (moisture content higher than 40 %), free of knots, visible decay, sapstain and mold, shall be used (Note 2). If the fungicide is to be used to protect hardwood, the inclusion of sapwood from a hardwood species is recommended.

NOTE 2—If wood for the test is collected in a sawmill where logs are stored in water, it is necessary to collect lumber from at least three different logs since depletion of nutrients during water storage may

strongly affect the growth of molds and staining fungi. Ensure that the lumber collected in a sawmill has not been treated with a sapstain and mold preventive, and if there is any doubt, at least 10 mm of surface wood must be removed and discarded.

7.2 *Size of Specimens*—Specimens should be 7 by 20 mm in cross section and 70 mm long.

7.3 *Preparation of Specimens*—Within two days of collecting, the samples shall be cut from the wood using a sharp saw blade. To prevent drying, the specimens shall be stored in polyethylene bags. For storage longer than one day, tightly packed specimens may be kept frozen (–20°C or lower) in polyethylene bags for up to one year. In this case, one bag should contain as many specimens as are used for one experiment.

8. Test Fungi³

8.1 *Hardwoods:*

8.1.1 *Sapstain Fungi:*

8.1.1.1 *Diplodia natalensis* P. Evans (ATCC 34643).

8.1.1.2 *Ceratocystis virescens* (Davidson) C. Moreau (ATCC 11066) a form of *C. coerulea* found on American hardwoods.

8.1.1.3 *Aureobasidium pullulans* (d. By) Arnaud. (ATCC 16624).

8.1.2 *Mold Fungi:*

8.1.2.1 *Trichoderma pseudokoningii* Rifai (ATCC 26801).

8.1.2.2 *Cephalosporium fragrans* Hanawa (ATCC 12091).

8.1.2.3 *Gliocladium roseum* (Link) Bainier (ATCC 10521).

8.2 *Softwoods:*

8.2.1 *Sapstain Fungi:*

8.2.1.1 *Diplodia natalensis* P. Evans (ATCC 34643).

8.2.1.2 *Ceratocystis pilifera* (Fr.) C. Moreau (ATCC 15457).

8.2.1.3 *Aureobasidium pullulans* (d. By) Arnaud (ATCC 16624).

8.2.2 *Mold Fungi:*

8.2.2.1 *Trichoderma pseudokoningii* (Rifai) (ATCC 26801).

8.2.2.2 *Cephalosporium fragrans* Hanawa (ATCC 12091).

8.2.2.3 *Gliocladium roseum* (Link) Bainier (ATCC 10521).

8.3 *General Consideration*—In addition to the above fungi, others that are known to cause discoloration on wood species used in test may be included, for example, *Cytospora* sp. (Pine); *Phialophora* sp.; *Graphium* sp.; *Ceratocystis* sp.; *Alternaria* sp.; *Penicillium* sp.; *Aspergillus* sp.; *Trichoderma* sp.

9. Culture Media

9.1 *Malt Agar Substrate*—For both stock culture tube and petri dish cultures of the test fungi, use a nutrient medium consisting of 2 % malt extract and 2 % agar. Sterilize the medium at 121°C, 15 psi (0.1 MPa) for 20 min.

10. Preparation for Inoculum

10.1 If the toxicity of a fungicide is being tested against individual fungi, maintain aseptic conditions when preparing the spore suspension; if the general effectiveness of a fungicide

is being tested using a mixed spore suspension, aseptic conditions are unnecessary. Most laboratory experiments require a relatively small volume (about 100 mL) of inoculum that may be prepared using only the stock test tube cultures; prepare larger volumes of inoculum from cultures grown on petri dishes.

NOTE 3—Before using any stock test tube culture, reinoculate new tubes for future use.

10.2 For the preparation of a spore suspension, add 5 mL of sterile water to each culture tube or 10 mL to petri dishes, and rub the surface of the malt agar culture with a blunt glass rod to loosen the spores. After collecting the spores and combining them with other similarly collected spores, if desired, adjust the water volume to that required. Although it is a good practice to prepare fresh spore suspensions just before use, they may be kept, even without refrigeration, for 2 to 3 weeks.

10.3 For nonsporulating cultures, obtain a mycelial suspension for use by aseptically scraping the surface mycelium off and blending it with sterile water.

10.4 To evaluate a fungicide use at least six test fungi (three sapstain and three mold) individually, as well as one mixed spore suspension of selected fungi.

11. Preparation of Test Chambers

11.1 To maintain high humidity in the petri dishes during the test period, place eight to ten layers of absorbent paper on the bottom of each dish. Wet the papers with water until free water appears, and press out any air bubbles trapped under and between the paper disks (thoroughly if the dishes are to be sterilized). Place a U-shaped glass rod (3 mm in diameter) on top of the papers and sterilize the petri dishes if required (Fig. 1).

11.2 *Aluminum Containers*—To maintain high humidity in the containers, treat as with the petri dishes. Instead of a U-shaped glass rod however, place two (2) straight rods (3 mm in diameter by 200 mm long) on top of the papers. Sterilize if required.

12. Treatment of Specimens

12.1 *Specimens*—If the wood samples were stored frozen, allow them to thaw in the polyethylene bags. Because of the variation in the susceptibility of wood to fungi, distribute an equal number of specimens from each log, into each treatment per fungus. If specimens were taken from lumber where log identity is not available, select the specimens randomly for testing. Autoclave the specimens before treatment at 121°C, 15 psi (0.1 MPa), for 20 min.

12.2 *Number of Specimens*—Use a minimum of ten specimens per concentration of a fungicide for each fungus tested. Also, use a minimum of ten untreated control specimens for each fungus tested.

12.3 *Preparation of Treating Solution*—Evaluate each fungicide using at least five concentrations. Select the lowest concentration of a fungicide or formulation to be below the expected effective strength and each of the following concentrations shall be twice the previous concentration. Start the preparation of the set of concentrations of each fungicide by preparing the highest concentration in an amount equal to twice

³ The following numbers refer to standard strains of test fungi maintained in the American Type Collection (ATCC), 12301 Parklawn Drive, Rockville, MD 20852.

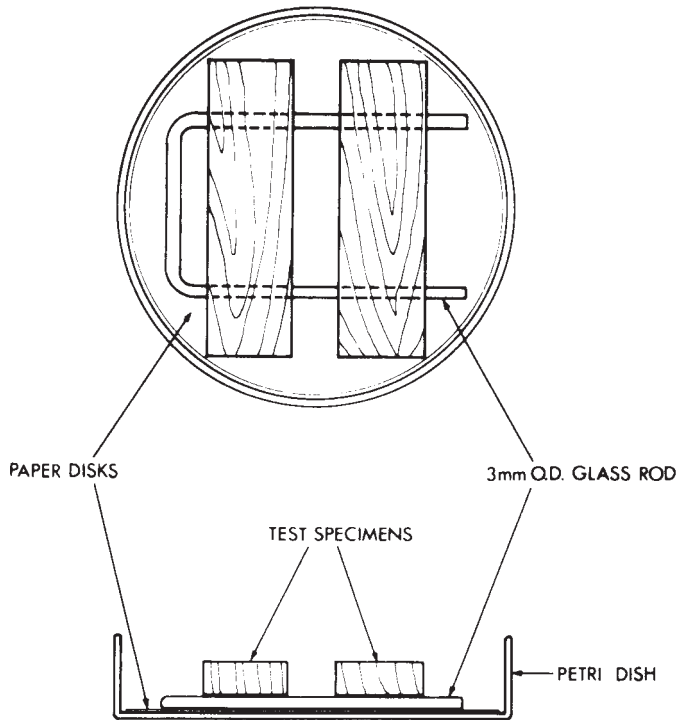

FIG. 1 Arrangement of Treated Wood Specimens Within the Petri Dishes Before Incubation

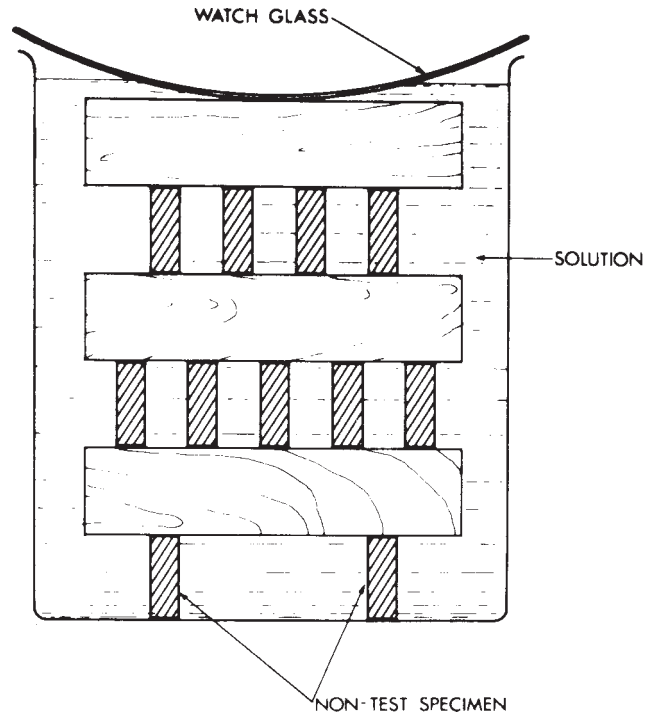

FIG. 2 Arrangement of Test Material for Treatment in a 600-mL Beaker

the volume required for treatment of the samples. Then dilute half of this preparation with an equal volume of water to obtain the next preparation. Therefore, a serial set of concentrations is prepared by continuing the dilutions in this way.

12.4 *Treating Procedure*—Carry out the treatment in a 600-mL beaker (Fig. 2). Place two unused test pieces edgewise on the bottom of the beaker, and the specimens, four or five in a layer, also on edge, crosswise on the previous layers until they reach the top, but not extending above the rim of the beaker. Holding down the specimens with a finger bearing down on a watch glass, pour the prepared solution into the beaker. After 15 s, pour the solution out, still holding the specimens down so that they cannot move. Similarly, treat untreated control specimens with water. After the treatment, tightly cover the beaker with a piece of plastic sheet to prevent drying, and store overnight. This allows draining of excess solution and time for the fungicide to be deposited or fixed in the wood before inoculation.

12.5 After overnight storage, place the samples into the prepared petri dishes or aluminum pans for inoculation.

13. Inoculation and Incubation

13.1 *Inoculation of the Specimens*—Stir the spore suspension frequently during inoculation. Perform inoculation using a transfer pipet fitted with a rubber bulb; streak about 0.25 mL of spore suspension along the length of one flat side of each specimen in the culture vessels. Application may also be accomplished by spraying. Allow a small amount of the spore suspension to run down on at least one of the crosscut ends.

13.2 Place the petri dishes in polyethylene bags to prevent drying and incubate at 25°C in an incubator preferably in the dark. Incubation time is between 2 and 4 weeks. Rewet the

paper pads with sterile water as necessary during the incubation period to maintain a “damp condition.”

13.3 Incubate the aluminum pans at 25°C for a period of between 2 and 4 weeks.

14. Evaluation of the Test

14.1 After 2 or 4 weeks, or both, estimate the growth of fungi visually and score using a scale of 0 to 5, the 5 being maximum intensity (Table 1). Base the estimate on the intensity of growth and discoloration, and not only on the surface area covered by the fungi, since the latter may be correlated only to the distribution of the original inoculum and not necessarily to the subsequent growth activity of the fungi.

TABLE 1 Fungicide Scoring After Incubation^A

Fungicide	Concentration in Treating Solution	C.f.	T.p.	M	Total Scores for Stain and Mold	Percent of Stain and Mold (Based on Control)
A	0 (control)	5.0	4.7	5.0	14.7	...
	0.011	2.2	4.3	5.0	11.5	78
	0.022	1.5	3.3	4.7	9.5	67
	0.045	0.9	1.6	2.0	4.5	31
	0.09	0.0	0.5	0.9	10.0	10
	0.18	0.0	0.1	0.1	0.1	0
NaTCP	0 (control)	5.0	4.3	5.0	14.3	...
	0.12	5.0	3.0	5.0	13.0	91
	0.24	5.0	1.5	5.0	11.5	80
	0.48	3.8	0.2	2.2	6.2	43
	0.96	2.5	0.5	1.5	4.5	31
	1.9	0.1	0.0	0.0	0.1	0

^A Scoring assessed after three weeks incubation, for two fungicides, “A” and sodium tetrachlorophenate (NaTCP) at five concentrations, using *Cephalosporium fragrans* (C.f.), *Trichoderma pseudokoningii* (T.p.) and a mixture (M) containing the spores of two *Penicillium* sp., *Aspergillus niger* and *Ceratocystis pilifera*. Each score is an average of eight samples.

14.2 Determine the effective concentration, or concentration for zero growth (CGo), as follows:

14.2.1 At each concentration, average the scores given for each fungus or for the mixed fungi, or both.

14.2.2 If the toxicity was tested with individual fungi or with more than one mixture of fungi, sum the average scores for each concentration (as shown under “Total” in Table 1).

14.2.3 Express fungal growth for each concentration as a percentage of the fungal growth in the controls (for example, in Table 1 at a concentration of 0.011 % for fungicide “A”),

$$\text{percent of total} = \frac{11.5}{14.7} \times 100 = 78$$

14.2.4 Plot the “percentage of total(s)” against the logarithm of treating solution concentration and draw the best-fit, straight line to these points (Fig. 3).

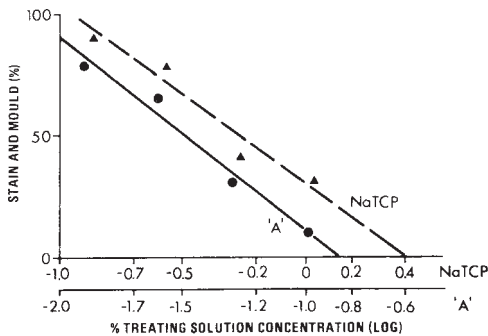

FIG. 3 Example of CGo Determination for Unknown Chemical A, Compared with Sodium Tetrachlorophenate (NaTCP). CGo for NaTCP is About 2.5 % and for Fungicide A is About 0.13 % (see 14.2.5)

14.2.5 The concentration where the line crosses the axis of treating solution concentration is the estimated CGo. For example, the line for Fungicide A crosses the X-axis at approximately -0.88 . The anti-log of -0.88 is 0.13, so the estimated CGo is 0.13 %.

14.3 If no growth is observed on untreated controls, discard all results from the test and repeat the test.

14.4 For the final evaluation, compare the results with the results from a similar test using a commercial sapstain and mold preventive, the effectiveness of which is well known (Table 1).

15. Report

15.1 Report the following information:

15.1.1 Species of wood,

15.1.2 Details of fungicide composition,

15.1.3 Fungi used (culture numbers),

15.1.4 Results and calculations presented in Table 1 and Fig. 3, and

15.1.5 Estimated chemical concentration for zero growth (CGo).

16. Precision and Bias

16.1 This test method is dependent upon the physiological action of living organisms. Therefore, the results may not be repeatable or reproducible. While the relative efficacy between experimental levels within each individual test group is obtainable, repeatability and reproducibility cannot be applied to make any inference of relative performance between different test groups.

17. Keywords

17.1 fungicides; lumber; mold; sapstain; test method

ASTM International takes no position respecting the validity of any patent rights asserted in connection with any item mentioned in this standard. Users of this standard are expressly advised that determination of the validity of any such patent rights, and the risk of infringement of such rights, are entirely their own responsibility.

This standard is subject to revision at any time by the responsible technical committee and must be reviewed every five years and if not revised, either reapproved or withdrawn. Your comments are invited either for revision of this standard or for additional standards and should be addressed to ASTM International Headquarters. Your comments will receive careful consideration at a meeting of the responsible technical committee, which you may attend. If you feel that your comments have not received a fair hearing you should make your views known to the ASTM Committee on Standards, at the address shown below.

This standard is copyrighted by ASTM International, 100 Barr Harbor Drive, PO Box C700, West Conshohocken, PA 19428-2959, United States. Individual reprints (single or multiple copies) of this standard may be obtained by contacting ASTM at the above address or at 610-832-9585 (phone), 610-832-9555 (fax), or service@astm.org (e-mail); or through the ASTM website (www.astm.org).