



Designation: D 5456 – 01a^{ε1}

Standard Specification for Evaluation of Structural Composite Lumber Products¹

This standard is issued under the fixed designation D 5456; the number immediately following the designation indicates the year of original adoption or, in the case of revision, the year of last revision. A number in parentheses indicates the year of last reappraisal. A superscript epsilon (ε) indicates an editorial change since the last revision or reappraisal.

^{ε1} NOTE—A Reference in A1.2.4 was corrected to 6.5.1 editorially in November 2001.

INTRODUCTION

Structural composite lumber is intended for use as an engineering material for a variety of end-use applications. The composition of the lumber varies by wood species, adhesive composition, wood element size, shape, and arrangement. To provide the intended performance, composite lumber products require: (1) an evaluation of the mechanical and physical properties and their response to end-use environments, and (2) establishment of and conformance to standard performance specifications for quality.

Procedures contained in this specification are also to be used for establishing the design properties and for checking the effectiveness of property assignment and quality assurance procedures.

The quality assurance sections in this specification are intended to serve as a basis for designing quality-control programs specific to each product. The objective is to ensure that design values established in the qualification process are maintained.

This specification is arranged as follows:

	Section
Qualification	6
Determination of Allowable Design Stresses	7
Independent Inspection	8
Quality Assurance	10

1. Scope

1.1 This specification recognizes the complexity of structural glued products. Consequently, this specification includes both specific procedures and statements of intent that sampling and analysis must relate to the specific product.

1.2 This specification was developed in the light of currently manufactured products as defined in 3.2. Materials that do not conform to the definitions are beyond the scope of this specification. A brief discussion is found in Appendix X1.

1.3 Details of manufacturing procedures are beyond the scope of this specification.

NOTE 1—There is some potential for manufacturing variables to affect the properties of members that are loaded for sustained periods of time. Users of this specification are advised to consider the commentary on this topic, in Appendix X1.

1.4 This specification primarily considers end use in dry service conditions such as with most protected framing mem-

bers, where the average equilibrium moisture content for solid-sawn lumber is less than 16 %. The conditioning environment of 6.3 is considered representative of such uses.

1.5 The performance of structural composite lumber is affected by wood species, wood element size and shape, adhesive and production parameters. Therefore, products produced by each individual manufacturer shall be evaluated to determine their product properties, regardless of the similarity in characteristics to products produced by other manufacturers. Where a manufacturer produces product in more than one facility, each production facility shall be evaluated independently. For additional production facilities, any revisions to the full qualification program in accordance with this specification shall be approved by the independent qualifying agency.

1.6 This specification is intended to provide manufacturers, regulatory agencies, and end users with a means to evaluate a composite lumber product intended for use as a structural material.

1.7 This specification covers initial qualification sampling, mechanical and physical tests, analysis, and design value assignments. Requirements for a quality-control program and cumulative evaluations are included to ensure maintenance of allowable design values for the product.

¹ This specification is under the jurisdiction of ASTM Committee D07 on Wood and is the direct responsibility of Subcommittee D07.02 on Lumber and Engineered Wood Products.

Current edition approved Sept. 10, 2001. Published November 2001. Originally published as D 5456 – 93. Last previous edition D 5456 – 01.

1.8 This specification, or parts thereof, shall be applicable to structural composite lumber portions of manufactured structural components.

1.9 The values stated in inch-pound units are to be regarded as the standard. The SI units given in parentheses are for information only.

1.10 *This standard does not purport to address all of the safety concerns, if any, associated with its use. It is the responsibility of the user of this standard to establish appropriate safety and health practices and determine the applicability of regulatory limitations prior to use.*

2. Referenced Documents

2.1 ASTM Standards:

- C 177 Test Method for Steady-State Heat Flux Measurements and Thermal Transmission Properties by Means of the Guarded-Hot-Plate Apparatus²
- C 355 Test Methods for Water Vapor Transmission of Thick Materials³
- C 384 Test Method for Impedance and Absorption of Acoustical Materials by the Impedance Tube Method²
- C 423 Test Method for Sound Absorption and Sound Absorption Coefficients by the Reverberation Room Method²
- D 7 Test Method for Sieve Analysis of Fine Aggregates⁴
- D 9 Terminology Relating to Wood⁵
- D 143 Test Methods for Small Clear Specimens of Timber⁵
- D 150 Test Methods for AC Loss Characteristics and Permittivity (Dielectric Constant) of Solid Electrical Insulating Materials⁶
- D 198 Test Methods of Static Tests of Lumber in Structural Sizes⁵
- D 245 Practice for Establishing Structural Grades and Related Allowable Properties for Visually Graded Lumber⁵
- D 669 Test Method for Dissipation Factor and Permittivity Parallel With Laminations of Laminated Sheet and Plate Materials⁶
- D 905 Test Method for Strength Properties of Adhesive Bonds in Shear By Compression Loading⁷
- D 1666 Methods for Conducting Machining Tests of Wood and Wood-Base Materials⁵
- D 1761 Test Methods for Mechanical Fasteners in Wood⁵
- D 2132 Test Method for Dust-and-Fog Tracking and Erosion Resistance of Electrical Insulating Materials⁶
- D 2394 Methods for Simulated Service Testing of Wood and Wood-Base Finish Flooring⁵
- D 2395 Test Methods for Specific Gravity of Wood and Wood-Base Materials⁵
- D 2559 Specification for Adhesives for Structural Laminated Wood Products for Use Under Exterior (Wet Use) Exposure Conditions⁷
- D 2718 Test Method for Structural Panels in Planar Shear (Rolling Shear)⁵

- D 2915 Practice for Evaluating Allowable Properties for Grades of Structural Lumber⁵
 - D 3201 Test Method for Hygroscopic Properties of Fire-Retardant Wood and Wood-Base Products⁵
 - D 3755 Test Method for Dielectric Breakdown Voltage and Dielectric Strength of Solid Electrical Insulating Materials Under Direct-Voltage Stress⁸
 - D 4442 Test Methods for Direct Moisture Content Measurement of Wood and Wood-Base Materials⁵
 - D 4761 Test Methods for Mechanical Properties of Lumber and Wood-Base Structural Material⁵
 - D 4933 Guide for Moisture Conditioning of Wood and Wood-Base Materials⁵
 - D 5055 Specification for Establishing and Monitoring Structural Capacities of Prefabricated Wood I-Joists⁵
 - D 5457 Specification for Computing the Reference Resistance of Wood-Based Materials and Structural Connections for Load and Resistance Factor Design⁵
 - D 5764 Test Method for Evaluating Dowel Bearing Strength of Wood and Wood-Based Products⁵
 - E 84 Test Method for Surface Burning Characteristics of Building Materials⁹
 - E 119 Test Methods for Fire Tests of Building Construction and Materials⁹
- ### 2.2 Canadian Standards:
- CAN3-O86-M84 Engineering Design in Wood (Working Stress Design)¹⁰
 - CSA Standards for Wood Adhesives, O112 Series¹⁰

3. Terminology

3.1 *Definitions*—Standard definitions of wood terms are given in Terminology D 9.

3.2 Definitions of Terms Specific to This Standard:

3.2.1 *laminated veneer lumber*—a composite of wood veneer sheet elements with wood fibers primarily oriented along the length of the member. Veneer thickness shall not exceed 0.25 in. (6.4 mm).

3.2.2 *parallel strand lumber*—a composite of wood strand elements with wood fibers primarily oriented along the length of the member. The least dimension of the strands shall not exceed 0.25 in. (6.4 mm) and the average length shall be a minimum of 150 times the least dimension.

3.2.3 *structural composite lumber*—in this specification, structural composite lumber (SCL) is either laminated veneer lumber (LVL) or parallel strand lumber (PSL). These materials are intended for structural use and they shall be bonded with an exterior adhesive.

3.2.3.1 *Discussion*—Structural composite lumber has three mutually perpendicular directions of orientation (see Fig. 1):

L Direction—Parallel to the longitudinal direction of the member.

X Direction—Parallel to a surface of the member and normal to the *L* direction.

Y Direction—Normal to both *L* and *X* direction.

In this specification, longitudinal shear means shear stress in the *L-X* and *L-Y* planes. Planar shear is stress in the *X-Y* plane.

² Annual Book of ASTM Standards, Vol 04.06.

³ Discontinued; see 1982 Annual Book of ASTM Standards, Part 18.

⁴ Discontinued; see 1937 Annual Book of ASTM Standards, Part 1.

⁵ Annual Book of ASTM Standards, Vol 04.10.

⁶ Annual Book of ASTM Standards, Vol 10.01.

⁷ Annual Book of ASTM Standards, Vol 15.06.

⁸ Annual Book of ASTM Standards, Vol 10.02.

⁹ Annual Book of ASTM Standards, Vol 04.07.

¹⁰ Available from Canadian Standards Association, 178 Rexdale Blvd., Toronto, Ontario, Canada M9W 1R3.

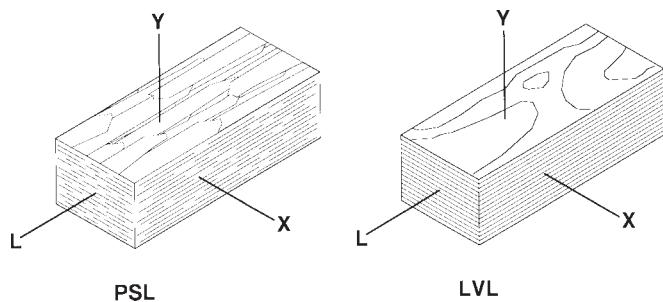

FIG. 1 Orientations for Structural Composite Lumber

4. Materials

4.1 *Wood Elements*—Wood elements used in the fabrication of SCL products shall conform to those specified in Section 3, Terminology.

4.2 *Adhesives*—Adhesives used in the fabrication of SCL products shall conform to the requirements in Specification D 2559 or, in Canada, to the appropriate section of CSA 0112 Series M standards for wood adhesives.

4.2.1 For high-temperature curing adhesives, the test samples shall be fabricated and tested in accordance with Specification D 2559 but with the following modifications:

4.2.1.1 The Shear by Compression Loading samples shall be fabricated by hot-pressing two 3/4-in. (19.1-mm) thick solid wood members in accordance with Test Method D 905 as allowed in Section 13.1.1 of Specification D 2559.

4.2.1.2 The Delamination During Accelerated Exposure samples shall be cut from a six-solid wood laminate member fabricated with four hot-set bondlines and one Specification D 2559–approved cold-set bondline in the center.

5. Mechanical Properties

5.1 The characteristic value for structural composite lumber is a statistic derived from test data as specified in 7.1. For bending and tension parallel to grain, the characteristic value is obtained at the unit volume as specified in 6.5.1 and 6.5.2.

5.2 The design stress related to structural composite lumber is derived from the characteristic value through application of the adjustments listed in Table 1 of this specification.

5.3 The allowable design stress published for engineering use shall be derived from the design stress modified by factors given in 7.3.

TABLE 1 Adjustment Factors

NOTE 1—Apparent modulus of elasticity is computed from a deformation, and compression strength perpendicular to grain is established at a deformation limit. Neither is subject to load duration adjustments. All other factors are the product of 1.62, that adjusts data to normal duration as defined in 7.3.1 of Practice D 245, and an additional factor for uncertainty.

Property	Adjustment Factor
Apparent modulus of elasticity	1.00
Bending strength	2.10
Tensile strength parallel to grain	2.10
Compressive strength parallel to grain	1.90
Longitudinal shear strength	3.15
Compressive strength perpendicular to grain	1.67

6. Qualification

6.1 Samples for qualification testing shall be representative of the population being evaluated. When an intentional modification to the process results in a reduction in mechanical properties as indicated by the quality-control program, then new qualification is required.

6.1.1 Qualification tests shall be conducted or witnessed by a qualified agency in accordance with 8.1. All test results are to be certified by the qualified agency.

6.2 Sampling of the test material shall be done in accordance with applicable portions of Section 3, “Statistical Methodology,” of Practice D 2915.

6.2.1 Design stress, except for compression perpendicular to grain and apparent modulus of elasticity, shall be based on the fifth percentile tolerance limit.

6.2.2 The confidence level for calculating tolerance limits and confidence intervals shall be 75 %.

6.2.3 Minimum sample size for calculating tolerance limits on fifth percentiles shall be 53. When volume effect tests are made at multiple sizes for bending and tension, the minimum sample shall be 78 specimens at the unit volume specimen size.

6.2.3.1 The calculated fifth percentile parametric tolerance limits (PTL) shall have a standard error no greater than 5 % of the PTL, when evaluated in accordance with 3.4.3.2 of Practice D 2915. When necessary the sample shall be increased beyond the minimum of 53, to meet this requirement.

6.2.4 Minimum unit sample sizes for compression perpendicular to grain (see 6.5.4) shall provide estimation of mean values within 5 % in accordance with 3.4.2 of Practice D 2915. Minimum sample size shall not be less than 30.

6.3 Composite lumber used in qualification testing shall be brought to moisture equilibrium in a conditioned environment of 20 ± 6°C (68 ± 11°F) and 65 % (±5 %) relative humidity. Methods for determination of completion of conditioning are given in Guide D 4933.

6.4 Moisture content and specific gravity shall be measured and reported for each specimen tested in the qualification program. Measurement for moisture content shall be in accordance with Test Methods D 4442 and measurement of specific gravity shall be in accordance with Test Methods D 2395.

6.5 *Mechanical Properties*—The properties that shall be evaluated by qualification testing shall include, but are not limited to: bending strength and stiffness, tensile strength parallel to the grain, compressive strength parallel to the grain, compressive strength perpendicular to the grain, and longitudinal shear strength.

6.5.1 *Bending*—Modulus of rupture and apparent modulus of elasticity shall be determined for both flatwise and edgewise bending in accordance with principles of Test Methods D 198 or Test Methods D 4761. Specimen cross section shall not be less than the minimum anticipated structural size. Selection of specimen dimensions establishes the unit volume for the analysis of 7.4.1. Loading at third points and a span to depth ratio in the range from 17 to 21 shall be used for flatwise and edgewise bending.

NOTE 2—A span to depth ratio of 18 is a frequent international standard.

6.5.1.1 When either or both the size and moisture content of the qualification specimens will differ from specimens to be tested in quality control, the bending tests of 6.5.1 shall also be conducted on specimens of the size and the moisture content that will prevail at the time of routine quality-control testing. The specimens representing the quality-control conditions shall be matched with those to be conditioned (see 6.3). The ratio of the means of both strength and stiffness shall be used to adjust quality-control test results to the qualification level, for use in the confirmation required in 10.6.1.

6.5.1.2 Moisture content is recognized as different when the discrepancy between the average of the two test sets is one percentage point of moisture content or more. Sample size shall be the same for both test sets and not less than 78.

6.5.1.3 If testing is required in accordance with 6.5.1.1, the coefficient of variation of the bending strength from those tests shall be the basis for comparison required in 10.6.3. Otherwise, the coefficient of variation of the bending strength from the tests in 6.5.1 shall be the basis.

6.5.2 *Tension Parallel to Grain*—Tension strength parallel to grain shall be tested in accordance with principles of Test Methods D 198 or Test Methods D 4761. Specimen cross section shall not be less than the minimum anticipated structural size. Specimen length shall provide for a minimum length of 36 in. (915 mm) between grips. Selection of specimen dimensions establishes the unit volume for the analysis of 7.4.1.

6.5.2.1 When either or both the size and moisture content of the qualification specimens will differ from specimens to be tested in quality control, the tension tests of 6.5.2 shall also be conducted on specimens of the size and the moisture content which will prevail at the time of routine quality-control testing. The specimens representing the quality-control conditions shall be matched with those to be conditioned (see 6.3). The ratio of the means of strength shall be used to adjust quality-control test results to the qualification level, for use in the confirmation required in 10.6.1. Moisture content is recognized as different when the discrepancy between the average of the two test sets is one percentage point of moisture content or more. Sample size shall be the same for both test sets and not less than 78.

6.5.2.2 If testing is required in accordance with 6.5.2.1, the coefficient of variation of the tensile strength from those tests shall be the basis for comparison required in 10.6.3. Otherwise, the coefficient of variation of the tensile strength from the tests in 6.5.2 shall be the basis.

6.5.3 *Compression Parallel to Grain*—Short-column compression strength parallel to grain shall be determined in accordance with principles of Test Methods D 198 or Test Methods D 4761. Minimum cross section shall be 1.5 by 1.5 in. (38 by 38 mm). Length of the specimen shall be such that L/r is less than 17 and greater than 15, where L is the effective unsupported length and r is the least radius of gyration.

6.5.4 *Compression Perpendicular to Grain*—Compressive strength perpendicular to grain shall be determined in accordance with principles of Test Methods D 143 except that references to placement of growth rings are not applicable and minimum cross-section dimension is 1.5 in. (38 mm). Stress at

both 0.02- and 0.04-in. (0.5- and 1.0-mm) deformation shall be reported. Testing shall be done with stresses applied normal to the L - X plane in one test series and to the L - Y plane in another series.

6.5.5 *Longitudinal Shear*—Longitudinal shear strength shall be determined in accordance with principles of Test Methods D 143 except that a minimum dimension of 1.5 in. (38 mm) at the shear area is acceptable provided that the total shear area is 4 in.² Testing shall be done to produce shear failure in the L - X plane in one test series and in the L - Y plane in another series.

6.5.5.1 If anticipated end use involves shear perpendicular to grain on a face of the material (planar shear), testing shall establish allowable shear stress in accordance with the principles of Test Method D 2718.

6.6 *Connections*—Determination of allowable design values for withdrawal capacities of nails, and dowel bearing capacities of bolts, lag screws, wood screws and nails is specified in Annex A2. Determination of allowable design values for other connectors is beyond the scope of this specification.

6.7 *Physical Properties*—Physical properties must be assessed when they affect end use. Information on physical properties and related standards is given in Appendix X1.

7. Determination of Allowable Design Stresses

7.1 Allowable design values developed in this section are consistent with engineering practice in building construction. Their applicability in other types of structures has not been evaluated and such applications require independent evaluation.

7.2 *Characteristic Value*—In the derivation of the characteristic value, the procedures of Sections 3 and 4 of Practice D 2915 shall be followed, except that provisions of this specification govern where differences occur.

7.2.1 The fifth percentile tolerance limit (TL) with 75 % confidence from test results of 6.5 shall be the characteristic value for strengths in flexure, tension parallel to grain, compression parallel to grain, and longitudinal shear.

7.2.1.1 Parametric or nonparametric analysis shall be performed to obtain a fifth percentile tolerance limit.

7.2.1.2 For parametric analysis either the normal or lognormal distribution shall be used to establish a fifth percentile tolerance limit with 75 % confidence. The distribution selection shall be based on standard statistical goodness of fit tests. As a minimum the fit selection shall include visual inspection of cumulative frequency plots of the fitted distributions with the data and the lesser of standard errors of the estimate from the two distributions fitted by the method of least squares.

NOTE 3—Experience has shown that data from SCL typically has coefficients of variation (COV) less than 20 % and is symmetrical to slightly right skewed and, therefore, are reasonably described by the normal and lognormal distributions. Goodness of fit references are given in Note 5 of Practice D 2915. The minimum procedures of 7.2.1.2 are detailed in X4.7 of Specification D 5055.

7.2.2 The average value for apparent modulus of elasticity from test results of 6.5.1 shall be the characteristic value for apparent modulus of elasticity.

7.2.3 The average value at 0.04-in. (1.0-mm) deformation for compression perpendicular to grain from test results of 6.5.4 shall be the characteristic value for compression perpendicular to grain.

7.3 *Design Stresses*—Design stresses shall be calculated from the characteristic value defined in 7.2 in accordance with the following formula:

$$S = \frac{B}{C_a} \quad (1)$$

where:

- S = design stress,
- B = characteristic value, and
- C_a = adjustment factor from Table 1.

7.4 *Allowable Design Stress*—Design stresses shall be modified by factors that consider the end-use applications as follows:

$$F_a = C_e S \quad (2)$$

where:

- F_a = allowable design stress,
- C_e = product of end use (K) factors, and
- S = design stress.

Factors common to all members are detailed in this section.

7.4.1 *Volume Factors:*

7.4.1.1 Strength properties are affected by the relative volume at a given stress. For purposes of this section, the members tested in edge bending or axial tension in Section 6 shall be taken as a unit volume. Sections other than solid rectangles, or solid rectangular sections not loaded axially or normal to one of its surfaces, require special investigation.

7.4.1.2 Volume factors shall either be determined from the prescribed theoretical relationships or by testing on a range of sizes, as detailed in Annex A1.

7.4.1.3 *Bending*—Bending design stress shall be adjusted for volume effect by multiplication with the factor as follows:

$$K_d = \left(\frac{d_1}{d}\right)^{2/m} = \left(\frac{d_1}{d}\right)^{1/n} \quad (3)$$

where:

- K_d = factor applied to design stress of the member of unit volume,
- d_1 = depth of unit volume members,
- d = depth of an application member,
- m = a parameter determined in accordance with Annex A1, and
- n = $m/2$

NOTE 4—A derivation of Eq 3 is given in Ref (1)¹¹ along with example data. In this case, volume considered is only two-dimensional since, at least within the limits given in Annex A1, increasing width of SCL bending members does not result in strength reduction. In some cases tests show a strength increase with increasing width, possibly because of greater stability along the compression edge. Therefore the two-dimensional form of the equation is of the form $K_d = (d_1/d)^{1/m}(L_1/L)^{1/m}$ where L_1 and L is the length of the unit volume and application member, respectively. When a constant span/depth ratio is assumed, Eq 3 becomes

$K_d = (d_1/d)^{2/m}$, which can be further simplified to $K_d = (d_1/d)^{1/n}$, where $n = m/2$.

7.4.1.4 *Axial Tension*—Tensile design stress shall be adjusted for volume by multiplication with factor as follows:

$$K_L = \left(\frac{L_1}{L}\right)^{1/m} \quad (4)$$

where:

- K_L = adjustment factor,
- L_1 = base length between grips tested in 6.5.2,
- L = end-use length, and
- m = parameter determined in accordance with Annex A1.

NOTE 5—Tension tests of SCL do not show strength reductions for increasing cross section so that volume is represented by length alone. Annex A1 states criteria for accepting this approach without limitations. Ref (1) gives example data.

7.4.1.5 When volume effect factors are based on single-size testing in accordance with A1.2.3, increased design stresses for members smaller than that tested are not permitted.

7.4.1.6 Other related conditions which influence the bending strength of a member include the loading diagram and support condition. Adjustments for common load cases are given in Annex A1 and other information is found in Ref (2).

7.4.2 Allowable design stresses developed in this specification correspond to the condition of normal loading as defined in 7.2 of Practice D 245 and 4.4.1 of CAN3-086-M84. These stresses shall be adjusted for other loading durations using the same factors applied to sawn lumber and other wood and wood-based structural members, as defined in Ref (3) or CAN3-086-M84.

7.4.3 Allowable design stresses developed in this specification are for use in dry conditions as defined in 1.4. If use at other moisture conditions is intended, a documented test-based investigation leading to appropriate properties adjustment must be carried out.

7.4.4 *Other End-Use Adjustments*—In some cases, end use requires other adjustments. A brief discussion of such use conditions is given in Appendix X1.

7.5 To convert allowable design stresses to load and resistance factor design (LRFD) format use the procedures of Specification D 5457.

8. Independent Inspection

8.1 A qualified agency shall be employed by the manufacturer for the purpose of monitoring the quality assurance and production process on a random unannounced basis. The qualified independent agency shall establish or approve and monitor procedures for quality assurance.

8.2 *Quality Agency*—A qualified agency is defined to be one that:

8.2.1 Has access to the facilities and trained technical personnel to verify that the grading, measuring, species, construction, bonding, workmanship, and other characteristics of the products as determined by inspection, sampling, and testing comply with all applicable requirements specified herein;

8.2.2 Has procedures to be followed by its personnel in performance of the inspection and testing;

¹¹ The boldface numbers in parentheses refer to a list of references at the end of the text.

8.2.3 Has no financial interest in, or is not financially dependent upon, any single company manufacturing the product being inspected or tested, and

8.2.4 Is not owned, operated, or controlled by any such company.

9. Manufacturing Standard

9.1 A manufacturing standard, subject to the approval of the qualified agency, shall be written and maintained by the manufacturer for each product and each production facility. This specification shall include provision for quality assurance.

10. Quality Assurance

10.1 *Quality Assurance in Manufacturing Standard*—This portion of the manufacturing standard shall include subject matter necessary to the quality-assurance program including the following:

10.1.1 Material specifications, including incoming material inspection and acceptance requirements, and

10.1.2 Quality assurance, inspection, testing, and acceptance procedures.

10.1.2.1 Sampling and inspection frequencies shall be devised to encompass all variables that affect the quality of the finished product. Increased frequencies shall be used in connection with new or revised facilities. A random sampling scheme shall generally be used for specimen selection.

NOTE 6—Increased sampling and test frequency is a useful procedure when investigating apparent data trends or adjustments in the process. It is desirable at times to deviate from a random sampling scheme while investigating effects of specific variables.

10.1.3 Procedures to be followed upon failure to meet specifications or upon out-of-control conditions shall be specified. Included shall be reexamination criteria for suspect material and material rejection criteria.

10.1.4 Finished product marking, handling, protection, and shipping requirements as they relate to the performance quality of the product shall be defined.

10.2 *Inspection Personnel*—All manufacturing personnel responsible for quality control shall demonstrate to the qualified agency that they have knowledge of the inspection and test procedures used to control the process of the operation and calibration of the recording and test equipment used and of the maintenance and interpretation of quality-control records.

10.2.1 Use of quality-control records beyond quality control, for monitoring and adjusting allowable design values, requires special recognition. The independent inspection agency and manufacturing quality-control personnel must maintain continuing awareness of this additional responsibility.

10.3 *Record Keeping*—All pertinent records shall be maintained on a current basis and be available for review by the qualified agency personnel. As a minimum, such records shall include:

10.3.1 All inspection reports and records of test equipment calibration, including identification of personnel carrying out the tests;

10.3.2 All test data, including retests and data associated with rejected production, and

10.3.3 Details of any corrective actions taken and the disposition of any rejected production resulting from tests or inspections.

10.4 *Quality Assurance Testing*:

10.4.1 *Testing Equipment*—Testing equipment is to be properly maintained, calibrated, and evaluated for accuracy and adequacy at a frequency satisfactory to the qualified agency.

10.4.2 *Required Tests*—The following shall be considered to be the scope of a minimum testing program:

10.4.2.1 The bending test described in 6.5.1 shall be used for quality assurance of bending strength and stiffness.

10.4.2.2 The tension test described in 6.5.2 shall be used for quality assurance of tensile strength parallel to grain.

10.4.2.3 Moisture content data shall be determined by the same process as in 6.4, at a frequency that provides a representative sample of production.

10.4.2.4 When required, quality assurance data shall be adjusted by the factors of 6.5.1.1 and 6.5.2.1 prior to further analysis.

10.4.2.5 Test frequency for all tests shall be chosen to yield quality-assurance performance that is consistent with design stresses assigned to the product and its intended use.

10.5 *Process Control*:

10.5.1 Data from the tests of 10.4 shall be evaluated prior to shipping material represented by the sample. Analytic procedures shall determine if material properties are in statistical control. The control level selected shall be consistent with current design values and intended use of the material.

NOTE 7—References (4), (5), and (6) provide useful background material on quality control.

10.5.2 When the analysis of 10.5.1 indicates that the material properties are below the control level, the associated portion of production shall be subject to reexamination in accordance with acceptance procedures of 10.1.3.

10.6 *Cumulative Evaluation*:

10.6.1 *Design Stresses*—Periodically, characteristic values and associated allowable stress values shall be formally checked using data accumulated in 10.4. At least one such check shall be made in the first six months of operation involving new production or from any new product line. Thereafter analysis shall be conducted at intervals not to exceed one year.

10.6.2 *Analysis*—The periodic analysis shall be conducted in accordance with 7.1, 7.2, and 7.3. All data from the period associated with statistical process control shall be included in the analysis.

10.6.2.1 Design values must be affirmed by the analysis of 10.6.2 or be reduced accordingly.

10.6.2.2 When design values have been reduced in accordance with 10.6.2.1 or at the option of the producer because of excessive reject rates, a new statistical process control level in keeping with the new design value shall be established. The evaluation then includes all data from the period in statistical control based upon the new control level.

10.6.3 *Volume Effect*—If the coefficient of variation of bending strength, as computed directly from data analysis in 10.6.2, has increased by one and one-half percentage points or

more over corresponding values determined in 6.5.1 or 6.5.2, the parameter (m) in Eq 3 and Eq 4 shall be recomputed using Eq A1.1.

11. Keywords

11.1 allowable design stresses; mechanical properties; quality assurance; structural composite lumber

ANNEXES

(Mandatory Information)

A1. VOLUME EFFECT PARAMETER DETERMINATION

A1.1 Scope

A1.1.1 This annex covers procedures that shall be used to determine the exponent in Eq 3 and Eq 4. Sections A1.2 and A1.3 define, for bending and tension respectively, the value of the exponent for single-size test data and the sampling procedures for multiple size testing. Section A1.4 gives a uniform procedure for processing multiple-size test data to determine the exponent for both bending and tension, experimentally.

A1.1.2 Limits on extrapolation beyond test data are given in A1.2.2 and apply to either single or multiple size specimen tests. Extrapolation beyond testing is not limited in tension, provided the requirements of A1.3.2 are met.

A1.2 Flexure

A1.2.1 If test data for only one specimen size are available as specified in 6.5.1 as a minimum requirement, the value of (m), Eq 3, 7.4.1.3, is given in A1.2.3 by specific formulation.

A1.2.2 Thicknesses greater than three times the maximum tested in 6.5.1 or A1.2.4 shall not be used in design without further tests incorporating greater thicknesses. Calculation of design stresses using the factor of Eq 3 shall be restricted to members not exceeding four times the volume (computed as length times depth) of the largest member tested.

A1.2.3 For single-size testing, the value of (m) is determined as follows:

$$m = C^{-1.08} \quad (\text{A1.1})$$

where:

- m = shape parameter of a two parameter Weibull distribution, and
- C = coefficient of variation (COV) of the data with the restriction that if $C < 0.15$ then $m = 8$.

NOTE A1.1—At $C = 0.15$, $m \sim 8$ so that $2/m = 1/4$. Specification of a minimum threshold of 0.15 on C is a default level to encourage multiple-size testing. Eq A1.1 is an approximation that simplifies and avoids the use of the gamma function. It gives estimates of (m) accurate to 2 % for COV's in the range from 0.05 to 0.30.

A1.2.4 Minimum sampling for multiple-size testing requires a minimum of four depths, including the base depth specified in 6.5.1, with sample sizes as specified in A1.2.5. The test range of volume (computed as length times depth) shall have a ratio of not less than 20 from the smallest depth to the

largest piece. Span to depth ratios in all test series shall be the same and as selected in 6.5.1. From Eq 3:

$$K_d = \left(\frac{d_1}{d} \right)^{2/m} \quad (\text{A1.2})$$

A1.2.5 Sample sizes below the base depth shall be 30 for each depth. Above the base depth the sample size, N , shall be determined by the following formula but not less than $N = 5$. Sample size for the base depth is given in 6.2:

$$N = 50 \left(\frac{d_1}{d} \right) \quad (\text{A1.3})$$

where:

- d_1 = base depth tested in 6.5.1, and
- d = any depth larger than base.

NOTE A1.2—The sample size equation is simple and judgmental. Experience on structural composite lumber has shown that test results from larger members are less variable. The expectation of lower variability for larger specimens in a weak link analysis can also be supported theoretically using a three parameter Weibull distribution. The end result is a reduction of COV for larger sizes and an approximate maintenance of statistical precision with fewer samples.

A1.3 Tension

A1.3.1 If test data have been obtained for only one specimen size, as a minimum requirement in 6.5.2, the value of (m), Eq 4, 7.4.1.4, is given by specific formulation.

A1.3.2 Eq 4 is used for any tension member provided the exponent developed agrees with theory when compared to the bending exponent. Members of cross-sectional area greater than three times the maximum tested in 6.5.2 or A1.3.4 shall not be used in design without additional tests involving greater cross sections.

NOTE A1.3—If the coefficient of variation is identical in tension and bending, the Weibull shape parameter, (m), will be the same. With differing coefficients of variation, the expected difference in exponents can be predicted from Eq A1.1.

A1.3.3 For single-length testing, the value of (m) is determined with Eq A1.1 using the COV of the tensile test data, if greater than 0.15, otherwise, $m = 8$.

A1.3.4 For multiple-length testing, minimum sampling requires four lengths, including the base length, with sample sizes as specified in A1.3.5. Minimum gage length (distance

ASTM D 5456 – 01a^{€1}

between grips) shall be 2 ft (610 mm) with the maximum gage length equal to or exceeding five times the minimum.

A1.3.5 Sample sizes below the base length shall be 30 for each length. Above the base length minimum sample sizes, N , shall be determined by the following formula with the constraint that N shall not be less than 20.

$$N = 50 \sqrt{\frac{L_1}{L}} \quad (A1.4)$$

where:

L_1 = base gage length tested in 6.5.2, and

L = any length longer than the base.

A1.4 Exponents from Multiple-Size Tests:

A1.4.1 Exponents for bending and tension are each calculated by two procedures. In each of the two cases an “empirical” exponent and a “theoretical” (m) are calculated. The relationships between empirical and theoretical values dictate a final choice for each case.

A1.4.2 The empirical procedure for a case requires logarithmic transformation of normalized average strengths and sizes and fitting a least squares line to these transformed data. The desired exponent for Eq A1.2 and Eq 4 is obtained by linear regression of transformed Variables x and y with a forced zero intercept of the fitted line in the x, y space. Eq A1.2 and Eq 4 are written as follows:

$$K = \left(\frac{Z_0}{Z}\right)^q \quad (A1.5)$$

where:

q = $2/m$ or $1/m$,

Z_0 = base depth or length, and

Z = test depth or length.

The ratio (K) in Eq A1.5 is the strength modification factor and in the data:

$$K = (F/F_0) \quad (A1.6)$$

where:

F = average experimental strength for test size Z , and

F_0 = average experimental strength for base size Z_0 .

Then use common logarithms and set as follows:

$$\text{Log} \left(\frac{F}{F_0}\right) = q \text{Log} \left(\frac{Z_0}{Z}\right) \quad (A1.7)$$

that is in the following form:

$$y = qx \quad (A1.8)$$

The empirical exponent ($q = 1/m$ or $2/m$) is obtained from the least squares computation as follows:

$$q = \frac{\sum xy}{\sum x^2} \quad (A1.9)$$

where summation is from the minimum through the maximum size tested.

A1.4.3 The theoretical procedure requires determination of the shape parameter, (m), of a two-parameter Weibull distribution fitted to the unit volume strength data. Tail fitting techniques, (an example is shown in Appendix X4 of Specification D 5055), are also acceptable provided 75 or more data

points are used and these points include at least the tenth-percentile experimental value. The theoretical exponent (Q) for Eq A1.2 or Eq 4 is $2/m$ or $1/m$ as determined in this procedure, for bending and tension respectively.

A1.4.4 The processes of A1.4.2 and A1.4.3 produce two curves of strength versus size for both bending and axial tension as follows:

$$F_1 = F_0 \left(\frac{Z_0}{Z}\right)^q \quad (A1.10)$$

and

$$F_2 = F_0 \left(\frac{Z_0}{Z}\right)^Q \quad (A1.11)$$

where:

q = is determined in A1.4.2, and

Q = is determined in A1.4.3.

A1.4.5 The curve fitted by the empirical procedure in A1.4.2 is acceptable for strength adjustment if (see Fig. A1.1 and Fig. A1.2):

A1.4.5.1 The theoretical curve of Eq A1.11 lies above the curve of Eq A1.10, or

A1.4.5.2 The Eq A1.10 curve value at the greater of four times Z_0 or 20 in. (508 mm) for bending and at 20 ft (6.1 m) for tension is not more than 5 % above the Eq A1.11 curve value using the latter as the basis for percentage calculation.

A1.4.5.3 If conditions A1.4.5.1 or A1.4.5.2 are not met, a new (q) exponent shall be determined such that condition A1.4.5.2 is satisfied.

A1.4.6 The final exponent determined in A1.4.5 shall be rounded to two decimal places and used to adjust bending and tension design stresses for volume effect.

NOTE A1.4—The empirical exponent (q) developed for bending statistically estimates ($2/m$ or $1/n$).

A1.5 *Adjustment for Loading*—Adjustments of flexure stress for types of loading are given in Table A1.1. These values vary according to the coefficient of variation (COV) of the base size data. The COV in Table A1.1 is an actual value unrelated to the special constraint on COV in A1.2.3 and A1.3.3 (the latter is an adjustment to cause size factors to be

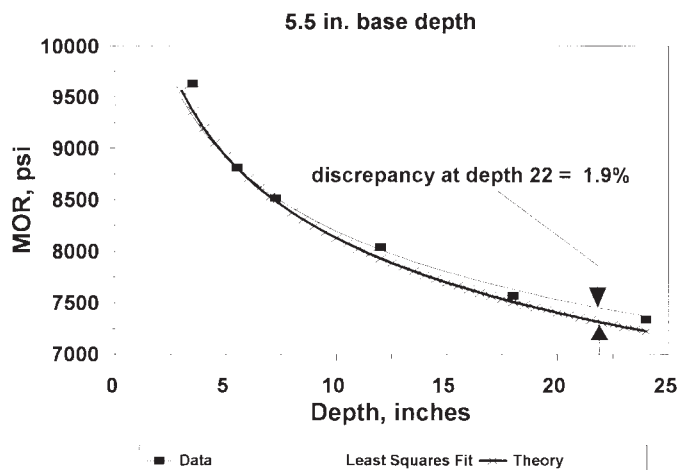

NOTE 1—1 in. = 25.4 mm.

FIG. A1.1 Bending Volume Effect

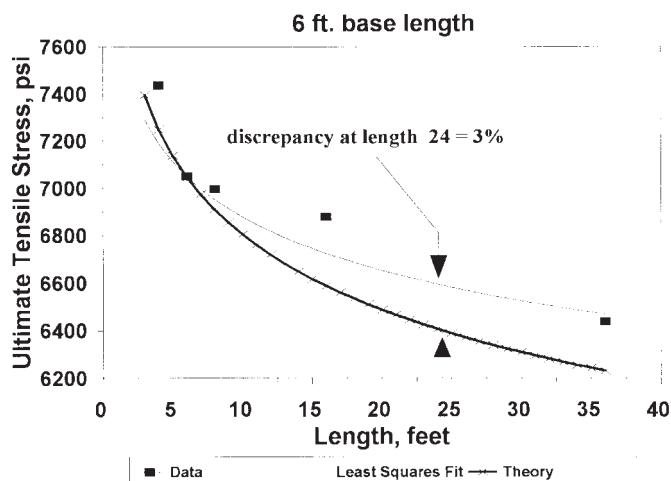

NOTE 1—1 in. = 25.4 mm.

FIG. A1.2 Tensile Length Effect

TABLE A1.1 Flexure Stress Adjustment Factors for Loading Conditions

NOTE 1—Table A1.1 is developed from weak-link theory and accounts for variations in stress distribution along the length of the member (that is, differences in moment diagram) for common cases. For example, if allowable bending stress is developed from third-point loading tests, for uniform load the allowable increases by 1/0.96 and the adjustment to center-point load would be 1.13/0.96, for COV = 15 %. The table factors are independent of volume adjustments.

Loading Conditions for Simply Supported Beams	Adjustment Factor		
	COV = 0.10	COV = 0.15	COV = 0.20
Center-Point Load	1.10	1.13	1.16
Third-Point Loads	0.96	0.96	0.96
Uniform Load	1.00	1.00	1.00

conservative when size effect has not been experimentally investigated).

A2. ESTABLISHING EQUIVALENT SAWN LUMBER SPECIES CONNECTION PROPERTIES FOR SCL

A2.1 Scope

A2.1.1 This annex presents one method for establishing equivalency for connection properties between a species of SCL and a species combination of sawn lumber. The equivalency is limited to withdrawal capacities of nails and bearing capacities of dowel type fasteners (bolts, lag screws, wood screws and nails).

NOTE A2.1—The method presented in this annex does not preclude the use of alternate methods of establishing equivalency of design values, such as direct comparative testing of joints.

A2.1.2 Equivalency is established by determining an equivalent specific gravity for a SCL product. The SCL equivalent specific gravity value is established by determining the specific gravity value of a solid sawn species or species combination in Ref. (3) that shows equivalent nail withdrawal or dowel bearing performance. This SCL equivalent specific gravity permits the design of connections in SCL using established design procedures and specific gravity values for species combinations of sawn lumber found in Ref (3).

A2.1.3 A different species combination equivalent specific gravity is permitted for fasteners installed in both the X and Y orientations (see Fig. 1) for both nail withdrawal and dowel bearing.

A2.2 Sample Size

A2.2.1 Minimum sample size for each test group shall provide 5 % precision of estimation of the mean value, with 75 % confidence, in accordance with 3.4.2 of Practice D 2915. Minimum sample size shall not be less than ten.

A2.3 Test Specimen

A2.3.1 Specimens shall be selected per 6.1 and conditioned in accordance with 6.3. Moisture content and specific gravity shall be measured and reported in accordance with 6.4.

A2.3.2 The average specific gravity of the test specimens shall not exceed the average specific gravity of the bending specimens from 6.5.1 by more than 0.03.

A2.4 Withdrawal Tests

A2.4.1 Withdrawal testing shall be performed for the Y orientation. When design values for the X orientation are desired, testing shall also be performed with the fastener in the X orientation. Testing for single nails in withdrawal shall be conducted in accordance with Test Methods D 1761.

A2.4.2 The withdrawal resistance in lb/in. (N/mm) of penetration of 0.131-in. (3.33-mm) diameter, 2.5-in. (64-mm) long (8d) steel common wire nails shall be determined. The nail penetration shall be based on the total penetration of the nail, including the point of the nail. The depth of penetration shall be a minimum of 1.25 in. (32-mm).

A2.5 Dowel Bearing Tests

A2.5.1 Testing for dowel bearing strength shall be conducted in accordance with Test Method D 5764. Testing for bolts and nails installed in the Y orientation and loaded in both the X and L directions is required. Testing for nails or bolts installed in the X orientation and loaded in both the Y and the L directions is required for applications utilizing nails or bolts installed in the X orientation.

A2.5.2 Rate of testing is in accordance with Test Method D 5764.

A2.5.3 Test configuration shall be in accordance with Test Method D 5764.

NOTE A2.2—Test Method D 5764 permits the use of either a half-hole or full-hole test configuration. The full hole test configuration as shown in Fig. A2.1 has been found to minimize specimen splitting that causes failure to occur prior to the point where the 5 % offset intersects the load-deformation curve ($P_{5\% \text{ off}}$).

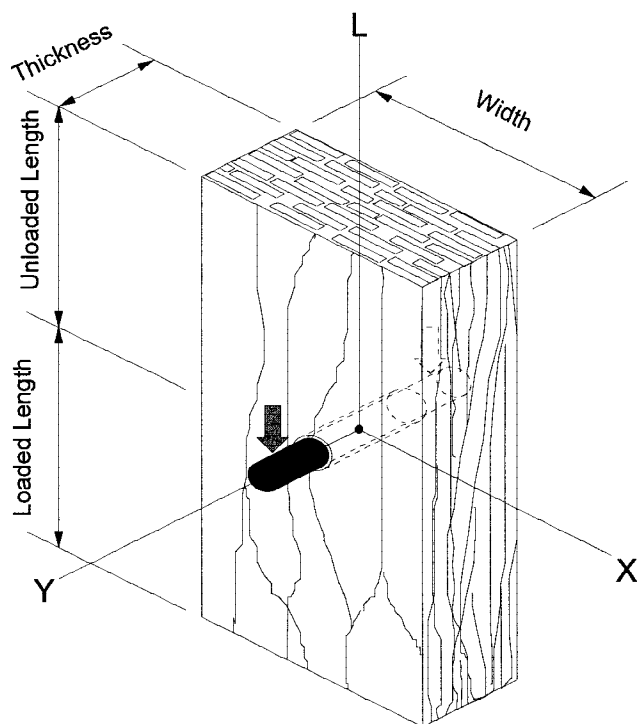

FIG. A2.1 Full Hole Test Configuration (Dowel in Y orientation, loaded in the L direction)

A2.5.4 Dowel bearing strength for one size of steel common wire nail shall be determined. Minimum size is 0.148-in. (3.76-mm) diameter, 3-in. (76-mm) long (10d common wire nail).

A2.5.5 The dowel bearing strength of 1/2-in. (12.7-mm) bolts and 3/4-in. (19-mm) diameter bolts shall be determined. Bolt length shall be sufficient to prevent bearing on the threads in the specimen.

A2.6 Withdrawal Equivalence

A2.6.1 The equivalent specific gravity is determined from Table 12.2A of Ref (3) such that the table value for the tested nail does not exceed the average ultimate withdrawal resistance in lb/in. (N/mm) from A2.4 divided by 5.0. Straight line interpolation between the nearest withdrawal design values in Table 12.2A of Ref (3) is permitted to obtain a closer approximation of SCL equivalent specific gravity.

A2.6.2 The specified testing establishes the equivalent specific gravity for the full range of nail types and sizes in Table 12.2A of Ref (3). A different species combination equivalent specific gravity is permitted for nails installed in the X and Y orientations. If one equivalent specific gravity is to be specified for both Y and X orientations then it shall be the lower of the two individual values.

NOTE A2.3—An example calculation is provided in Appendix X2.

A2.7 Dowel Bearing Equivalence

A2.7.1 Nails:

The nail dowel bearing strength is determined by dividing $P_{5\%off}$ from A2.5 by the nail diameter and specimen dimension parallel to the nail length. The dowel bearing strength for nails

installed in a specific orientation (either X or Y) shall combine the average of the test results from both loaded directions provided that they do not differ from the average of the test results from either of the loaded directions by more than 20 %. If the individual dowel bearing results for each orientation differ by more than 20 % from the combined average, then the dowel bearing strength shall be equal to the lower test value of both loaded directions divided by 0.8.

NOTE A2.4— $P_{5\%off}$ is the load at which a line parallel to the initial slope of the load-deformation curve and offset by an amount equal to 5 % of the dowel diameter, intersects the load-deformation curve or the maximum load, whichever occurs first.

A2.7.2 The equivalent specific gravity value for laterally loaded nails shall be determined from Table 12A of Ref (3) such that the table value of dowel bearing strength does not exceed the average dowel bearing strength from A2.7.1. The equations contained in the footnotes of Table 12A can be used to obtain a closer approximation of SCL equivalent specific gravity. If dowel bearing tests are conducted in both the X and Y orientations, then an equivalent specific gravity value shall be determined for each orientation. If one equivalent specific gravity is to be specified for both Y and X orientations then it shall be the lower of the two individual values.

A2.7.3 The results from the nail tests can also be applied to wood screws.

A2.7.4 Bolts—The equivalent specific gravity value for laterally loaded bolts shall be determined from Table 8A of Ref (3) such that the table value of dowel bearing strength does not exceed $P_{5\%off}$ from A2.5 divided by the bolt diameter and by the specimen dimension parallel to the bolt length. The equations contained in the footnotes of Table 8A can be used to obtain a closer approximation of SCL equivalent specific gravity.

A2.7.5 Equivalent specific gravity values for design use with bolts shall be the average of individual equivalent specific gravity values for all bolt diameters and load directions for a given orientation (X or Y) provided that they do not differ from the average of the test results by more than 0.03. If the individual equivalent specific gravity values for each orientation differ by more than 0.03 from the combined average, then the average equivalent specific gravity shall be equal to the lowest test value of all bolt diameters and load directions evaluated plus 0.03 for a given orientation. If dowel bearing tests are conducted in both the X and Y orientations then an equivalent specific gravity value shall be determined for each orientation. If one equivalent specific gravity is to be specified for both Y and X orientations then it shall be the lower of the two individual values.

NOTE A2.5—An example calculation is provided in Appendix X2.

A2.7.6 The results from bolt tests can also be applied to lag screws.

A2.7.7 The specified testing establishes the equivalent specific gravity values for the full range of dowel-type (bolts, lag screws, wood screws, and nails) fasteners within the scope of Ref (3).

A2.8 Presentation of Connection Properties

A2.8.1 Presentation of connection properties shall state the specific gravity of the equivalent sawn lumber species combination for each fastener type and product orientation evaluated.

APPENDIXES

(Nonmandatory Information)

X1. COMMENTARY ON LIMITATIONS OF APPLICABILITY AND POSSIBLE END-USE CONSIDERATIONS

X1.1 Scope

X1.1.1 This appendix discusses the need for limiting the applicability of this specification to materials corresponding to the descriptions of 3.2 and the need for carefully devised and controlled manufacturing procedures.

X1.1.2 This appendix provides a partial list of considerations that may be important in end use. Included are design considerations and conditions that may affect both mechanical and physical properties. Standards that are helpful in evaluating these concerns are given.

X1.2 Limitations to the Applicability of This Specification:

X1.2.1 The potential variety of wood-based structural composites is very great. The committee felt that the applicability of this specification should be limited to general composite types for which there is a reasonable body of technical knowledge. It is intended that the descriptions of 3.2 be modified as the knowledge base expands.

X1.2.2 Manufacturing variables will, of course, be reflected in the data generated by the investigations detailed in this specification, but there may be subtle effects not apparent. A particular concern brought before the committee was the importance of considering performance when load is applied for sustained time periods.

X1.2.2.1 Generally, it is expected that composites as defined in this specification will perform similarly to other wood structural members when subjected to load for sustained periods. It is possible, however, that manufacturing procedures will adversely affect this performance.

X1.2.2.2 Reference (7), for example, shows a marked sustained-load performance difference between two products of identical composition (aspen strands averaging 8.6 in. in length and 0.054 in. thick; MDI adhesive) when pressed in different equipment, even though results from standard tests (see Test Methods D 198) were nearly identical for the two products. The aspen was densified approximately 50 %, “Product A” in a steam injection press; “Product B,” which had a large number of failures in the six month test period, in a conventional hot-platen press. The suspected reason for the difference was degree of plasticization during densification, with the second process producing fractures in the microstructure.

X1.2.2.3 There may be numerous manufacturing parameters that adversely affect sustained-load performance. Two others suspected are: too low adhesive spread or erratic bond quality, and damage due to improperly controlled time/temperature cycles.

X1.2.2.4 The traditional wood member adjustment from test to basic (normal duration) design values is included in the factors of Table 1. For design, other adjustments are made as defined in 7.4.2. These factors were judged appropriate for use with properly manufactured materials covered by this specification. There is no standard procedure for establishing how well any wood members correspond to the time-under-load effect implied in the above referenced section of this standard. The adjustment to normal duration in setting design values and application design adjustments are judgmental, based upon long experience and consideration of research in the area. At present, Committee D07 is working on a standard for testing requirements and data evaluation relative to long-term performance.

X1.2.2.5 The users of this specification are advised to carefully evaluate the entire manufacturing process of any structural composite lumber product, for conformance with well-established procedures. When doubts exist, sustained-load tests should be conducted.

X1.2.2.6 Certain proprietary materials, that conform to the descriptions of 3.2, have been subjected to time-under-load testing. Outlines of procedures which have been followed and data summaries are given in Refs (8-10).

X1.3 Design and Mechanical Property Concerns:

X1.3.1 *Creep and Relaxation*—Creep and relaxation are a function of stress and environment, particularly moisture content and cyclic changes of moisture and should be considered in applications sensitive to long-term deformation or stress relaxation.

X1.3.2 *Moisture Service Environment*—If the material is to be used in other than a dry service environment, the performance of members used in other service conditions should be evaluated, including development of appropriate strength reduction factors.

X1.3.3 *Treating*—The performance of the material should be evaluated for the effect of preservative or fire-retardant chemicals and treating processes.

X1.3.4 Temperature—The performance of the material should be evaluated for the effect of temperature if the material is to be exposed to temperatures outside the range from –30 to 150°F (–34 to 65°C), for sustained periods.

X1.3.5 Fire Resistance—The performance of structural composite lumber material under fire conditions should be evaluated. Full-scale assembly tests may be required in accordance with Test Methods E 119. Alternatively, material property tests may sometimes be substituted for full-scale tests.

X1.3.6 Flame Spread— When necessary, the flame spread of the composite material should be determined in accordance with Test Method E 84.

X1.3.7 Char Rate—The char rate of the composite material can be determined in accordance with the method described in Ref (11).

X1.3.8 Flexure at Elevated Temperature—The flexural strength of the composite material at elevated temperature can be evaluated by subjecting structural-sized specimens to temperatures of 500°F (260°C) under full design load. Measurements of deflection and time to failure should be made during the test, as well as a record of the temperature during the test.

X1.3.9 Row Nailing— Size, spacing, and penetration of nails aligned in a row can induce splitting of all lumber products at critical combinations of these variables. When row

nailing of this critical nature is anticipated, tests should be conducted to determine limits for each orientation of the material involved.

X1.3.10 Component Use— The influence of the interaction between several members and the quality of fabrication should be considered in the adjustment of allowable design stresses for material intended for use in components. Components may include such structural forms as trusses or built-up sections. Built-up sections require consideration of volume effects in the cross section.

X1.3.11 Other—If the material will be subjected to other conditions for which the product performance is unknown, appropriate product testing should be conducted.

X1.4 Physical Properties and Standards:

X1.4.1 Electrical Conductivity/Dielectric Properties—See Test Methods D 150, D 669, D 2132, and D 3755.

X1.4.2 Thermal/Environmental Properties—See Test Methods C 177 and C 355.

X1.4.3 Acoustical Properties—See Test Methods C 384 and C 423.

X1.4.4 Hygroscopic Properties—See Test Method D 3201.

X1.4.5 Coefficient of Friction—See Methods D 2394.

X1.4.6 Machining—See Methods D 1666.

X2. EXAMPLE PROCEDURE TO DETERMINE SCL NAIL WITHDRAWAL AND DOWEL BEARING EQUIVALENT SPECIFIC GRAVITY VALUES

X2.1 Scope

X2.1.1 This appendix provides example calculations for determining the equivalent specific gravity values for the range of dowel connectors and product orientations specified in this standard. The rules for combining results for different product orientations and load directions are consistent with those used to develop nail withdrawal and dowel bearing capacities for solid sawn lumber Refs (3, 12). The data provided was chosen to illustrate the rules for combining results or equivalent specific gravity values.

X2.1.2 The results of withdrawal and dowel bearing tests conducted on a SCL product in accordance with procedures of Annex A2 are summarized in Tables X2.1 and X2.2.

X2.2 Determination of Withdrawal Equivalent Specific Gravity Values for Nails

X2.2.1 From Table X2.1 and SG values interpolated from Table 12.2A of Ref (3) the equivalent SG values in Table X2.3 were determined.

X2.2.2 Use the withdrawal design load in the NDS for $SG_Y=0.54$ for the Y-orientation and $SG_X=0.50$ for the X-orientation or use lower value ($SG=0.50$) if one value is specified for both orientations.

TABLE X2.1 Nail Withdrawal Test Results

Nail Type	Dowel Diameter, in.	Penetration Depth, in.	Average Withdrawal Load, lb	
			Y Orientation	X Orientation
8d Common	0.131	1.25	250	200

TABLE X2.2 Dowel Bearing Test Results

Dowel Type	Dowel Bearing Strength, psi			
	Dowel in Y Orientation (perpendicular to glueline)		Dowel in X Orientation (parallel to glueline)	
	Loaded in:			
	L Direction	X Direction	L Direction	Y Direction
10d Common Nail	7680	5750	6680	4000
1/2-in. diameter Bolt	6840	3820	6400	2850
3/4-in. diameter Bolt	7050	3270	6600	2500

TABLE X2.3 Equivalent SG Values

Nail Diameter, in.	Nail Withdrawal Strength, lb					
	Nail in Y Orientation (perpendicular to glueline)			Nail in X Orientation (parallel to glueline)		
	Strength Per Inch of Penetration	Allowable Strength Per Inch	Equivalent SG_Y	Strength Per Inch of Penetration	Allowable Strength Per Inch	Equivalent SG_X
0.131 (8d Common)	200	40	0.54	160	32	0.50

X2.3 Determination of Dowel Bearing Equivalent Specific Gravity Values for Nail Connections

X2.3.1 From Table X2.2 and SG values interpolated from Table 12A of Ref (3), the equivalent SG values in Table X2.4 were determined.

X2.3.2 For the Y orientation, the individual dowel bearing strength results do not differ by more than 20 % of the average, therefore the equivalent SG is based on 6715 psi and SG_Y equals 0.61.

X2.3.3 For the X orientation, the individual dowel bearing strength results differ by more than 20 % of the average,



TABLE X2.4 Dowel Bearing Strength for Nail Connections

Dowel Type	Dowel Bearing Strength, psi									
	Nail in Y Orientation (perpendicular to glueline)					Nail in X Orientation (parallel to glueline)				
	Strength in:		Average	Equivalent SG _Y per Table 12A		Strength in:		Average	Equivalent SG _X per Table 12A	
L Direction	X Direction	Based on Average Strength		Specified	L Direction	Y Direction	Based on Average Strength		Specified	
10d nail	7680	5750	6715	0.61	0.61 ^A	6680	4000	5340	0.54	0.52 ^B

^A See X2.3.2.

^B See X2.3.3.

therefore the equivalent SG is not based on the average strength but is based on the lower strength value of 4000 divided by 0.8 which yields 5000 psi and therefore the equivalent SG_X equals 0.52.

X2.4 Determination of Dowel Bearing Equivalent Specific Gravity Values for Bolted Connections

X2.4.1 From Table X2.2 and SG values interpolated from Table 8A of Ref (3), the equivalent SG values in Table X2.5 were determined.

X2.4.2 For the Y orientation, the individual equivalent SGs for each bolt diameter and load direction do not differ by more than 0.03 from the average equivalent SG_Y, therefore the equivalent SG_Y equals 0.60.

X2.4.3 For the X orientation, the individual equivalent SGs for each bolt diameter and load direction differ by more than 0.03 from the average equivalent SG_X, therefore the equivalent SG is determined as the lowest equivalent SG (0.47) plus 0.03 to give an equivalent SG_X equaling 0.50.

X2.5 Determination of Equivalent Species Combination for Dowel-Type Fasteners

X2.5.1 The equivalent SG values determined in X2.2-X2.4 are summarized in Table X2.6 along with the lower, nearest wood species combination group found in Table 8A or 12A of Ref (3).

X2.5.2 The equivalent species combination group for nail and screw fasteners is determined to be as follows:

X2.5.2.1 *Withdrawal*—Y orientation only: Mixed Southern Pine (SG = 0.51); X orientation only: Douglas Fir - Larch (SG = 0.50); and Y and X orientation combined: Douglas Fir - Larch (SG = 0.50).

X2.5.2.2 *Dowel Bearing Strength*—Y orientation only: Red Maple (SG = 0.58); X orientation only: Mixed Southern Pine (SG = 0.51); and Y and X orientation combined: Mixed Southern Pine (SG = 0.51).

X2.5.3 The equivalent species combination group for dowel bearing strength for bolt and lag screw fasteners is determined to be: Y orientation only: Red Maple (SG = 0.58); X orientation only: Douglas Fir - Larch (SG = 0.50); and Y and X orientation combined: Douglas Fir - Larch (SG = 0.50).

TABLE X2.5 Dowel Bearing Strength for Bolted Connections

Dowel Diameter, in.	Dowel Bearing Strength, psi											
	Bolt in Y Orientation (perpendicular to glueline)						Bolt in X Orientation (parallel to glueline)					
	Strength in L Direction		Strength in X Direction		Equivalent SG _Y		Strength in L Direction		Strength in Y Direction		Equivalent SG _X	
Fe	SG	Fe _⊥	SG _⊥	Average	Specified	Fe	SG	Fe _⊥	SG _⊥	Average	Specified	
1/2	6840	0.61	3820	0.57	0.60	0.60 ^A	6400	0.57	2850	0.47	0.53	0.50 ^B
3/4	7050	0.63	3270	0.59			6600	0.59	2500	0.49		

^A See X2.4.2.

^B See X2.4.3.



TABLE X2.6 Summary Equivalent SG Results

Fastener	Test	Y Orientation		X Orientation	
		Equivalent SG _y	Nearest Species Combination (SG)	Equivalent SG _x	Nearest Species Combination (SG)
Nail	Withdrawal	0.54	Mixed Southern Pine (0.51)	0.50	Douglas Fir — Larch (0.50)
	Dowel Bearing	0.61	Red Maple (0.58)	0.52	Mixed Southern Pine (0.51)
Bolt	Dowel Bearing	0.60	Red Maple (0.58)	0.50	Douglas Fir — Larch (0.50)

REFERENCES

- (1) Sharp, D. J., and Suddarth, S. K., "Volume Effects in Structural Composite Lumber," *Proceedings*, 1991 International Timber Engineering Conference, London.
- (2) Liu, J. Y., "A Weibull Analysis of Wood Member Bending Strength," *Transactions of ASME*, Vol 104, 1982.
- (3) American Forest Products and Paper Association, "National Design Specification for Wood Construction," Washington, DC, (NDS), 1997.
- (4) *MNL7/Manual on Presentation of Data and Control Chart Analysis*, Sixth Edition, ASTM, Philadelphia, 1990.
- (5) Natrella, M. G., "Experimental Statistics," *National Bureau of Standards Handbook 91*, U.S. Government Printing Office, 1963.
- (6) AT&T Technologies, *Statistical Quality Control Handbook*, PO Box 1901, Indianapolis, IN.
- (7) Bledsoe, J. M., et al., "Creep Rupture Testing, A Necessary Part of Structural Composite Lumber Development," presented at *24th International Particleboard/Composite Materials Symposium*, Pullman, Washington. Available from ASTM Headquarters, April 1990.
- (8) Craig, B., "Parallam PSL; Exterior Structural Performance," in *Proceedings, Engineered Wood Seminar for the Electric Utility Industry*, MacMillan Bloedel Parallam Division (now Trus Joist, A Weyerhaeuser Business), 1272 Derwent Way, Annacis Island, British Columbia, Canada V3M 5R1, October 1990.
- (9) Pellerin, R. F., et al., "Duration of Load Characteristics of Structural Members in Bending and Tension," Washington State University, College of Engineering, *Bulletin 340*, 1976.
- (10) Pellerin, R. F., et al., *The Evaluation and Comparison of Creep Performance of TecLam Laminated Veneer Lumber and Douglas Fir Dimension Lumber*, Tecton, PO Box 587, Hines, Oregon 97738.
- (11) "Charring Rate of Selected Woods—Tranverse to Grain," U.S. Forest Service Research Paper, *FLP69*, April 1967.
- (12) Wilkinson, T. L., "Dowel Bearing Strength," USDA Forest Products Laboratory Paper, *FPL-RP-505*, 1991.

ASTM International takes no position respecting the validity of any patent rights asserted in connection with any item mentioned in this standard. Users of this standard are expressly advised that determination of the validity of any such patent rights, and the risk of infringement of such rights, are entirely their own responsibility.

This standard is subject to revision at any time by the responsible technical committee and must be reviewed every five years and if not revised, either reapproved or withdrawn. Your comments are invited either for revision of this standard or for additional standards and should be addressed to ASTM International Headquarters. Your comments will receive careful consideration at a meeting of the responsible technical committee, which you may attend. If you feel that your comments have not received a fair hearing you should make your views known to the ASTM Committee on Standards, at the address shown below.

This standard is copyrighted by ASTM International, 100 Barr Harbor Drive, PO Box C700, West Conshohocken, PA 19428-2959, United States. Individual reprints (single or multiple copies) of this standard may be obtained by contacting ASTM at the above address or at 610-832-9585 (phone), 610-832-9555 (fax), or service@astm.org (e-mail); or through the ASTM website (www.astm.org).