



# Standard Test Method for Evaluating Dowel-Bearing Strength of Wood and Wood-Based Products<sup>1</sup>

This standard is issued under the fixed designation D 5764; the number immediately following the designation indicates the year of original adoption or, in the case of revision, the year of last revision. A number in parentheses indicates the year of last reapproval. A superscript epsilon ( $\epsilon$ ) indicates an editorial change since the last revision or reapproval.

## 1. Scope

1.1 This test method provides the basic procedure for evaluating dowel-bearing strength of wood and wood-based products. The bearing test results are used to determine the static load resistance and deformation characteristics of connections in wood and wood-base products resulting from the application of a load transmitted by a fastener inserted into a predrilled hole, or driven without drilling. Methods are given for preparing specimens with predrilled holes larger than the fastener diameter and specimens with holes produced by inserting fasteners in holes smaller than the fastener diameter. The methods apply to fasteners such as dowels, bolts, nails, spikes, drift pins, screws, lag screws, and staples.

1.2 This test method also provides the basis for determining the compression behavior of wood products beneath a laterally loaded fastener where the thickness of the product and the diameter of the fastener are such that minimal bending of the fastener occurs during testing.

1.3 *This standard does not purport to address all of the safety concerns, if any, associated with its use. It is the responsibility of the user of this standard to establish appropriate safety and health practices and determine the applicability of regulatory limitations prior to use.*

## 2. Referenced Documents

### 2.1 ASTM Standards:

D 143 Methods for Testing Small Clear Specimens of Timber<sup>2</sup>

D 2395 Test Methods for Specific Gravity of Wood and Wood-Based Materials<sup>2</sup>

D 2915 Practice for Evaluating Allowable Properties for Grades of Structural Lumber<sup>2</sup>

D 4442 Test Methods for Direct Moisture Content Measurement of Wood and Wood-Base Materials<sup>2</sup>

<sup>1</sup> This test method is under the jurisdiction of ASTM Committee D07 on Wood and is the direct responsibility of Subcommittee D07.05 on Wood Assemblies.

Current edition approved Oct. 10, 1997. Published March 1998. Originally published as D 5764 – 95. Last previous edition D 5764 – 97.

<sup>2</sup> *Annual Book of ASTM Standards*, Vol 04.10.

E 4 Practices for Force Verification of Testing Machines<sup>3</sup>

## 3. Terminology

### 3.1 Definitions:

3.1.1 *dowel-bearing behavior*—the load-deformation behavior of wood or wood-base products laterally loaded by a fastener where the fastener does not bend during loading.

3.1.2 *dowel-bearing strength*—yield load obtained from the load-deformation curve of a dowel-bearing test divided by the dowel diameter and specimen thickness.

## 4. Summary of Test Method

4.1 Specimens consisting of a single rectangular parallelepiped member with a fastener hole perpendicular to the faces of the member are evaluated for the resistance to embedding the fastener into the fastener hole, so as not to bend the fastener. Tests are conducted on a testing machine at a uniform deformation rate, while loads and deformation are measured at various intervals. Supplementary physical properties of the wood or wood-base member are also determined.

## 5. Significance and Use

5.1 The localized crushing behavior of wood or wood-base products beneath a fastener where the fastener does not bend provides a material property that is used in theoretical models for connections where crushing or fastener bending, or both, occur. These theoretical models are used to establish design values for wood and wood-base connections. The tests are appropriate when studying the effects of such variables as fastener diameter, fastener hole size, moisture content, specific gravity, and grain direction on the dowel-bearing strength.

## 6. Apparatus

6.1 *Testing Machine*—Any suitable testing machine capable of operation at a constant rate of motion of its movable head and having an accuracy of  $\pm 1\%$  when calibrated in accordance with Practices E 4.

<sup>3</sup> *Annual Book of ASTM Standards*, Vol 03.01.

6.2 *Deformation Gage*—A deformation-measuring device, with a least reading of 0.001 in. (0.025 mm) for measuring the movement of the fastener into the wood or wood-base specimen.

7. Sampling

7.1 Sampling shall provide for selection of representative test specimens which are appropriate to the objectives of the testing program.

7.2 Sample size shall be estimated using procedures in Practice D 2915.

NOTE 1—The precision required, the manner of sampling, and the number of tests will depend upon the specific test objectives. General experience indicates that the coefficient of variation from embedment tests ranges from 15 to 30 %.

8. Specimens

8.1 Wood members shall be selected, and the dowel positioned in such a way that the results are not affected by knots, cross grain, or other natural or manufacturing characteristics, unless the objective of the study is to determine the effect of such variables. Frequently, this will necessitate selecting members which are essentially clear and straight grained. For wood-based products, specimens shall be selected with regard to manufactured characteristics.

8.2 Specimen Dimensions:

8.2.1 Specimens shall consist of a rectangular parallelepiped member with half a dowel hole across one face (see Fig. 1).

8.2.2 For solid wood and wood composites, minimum dimensions shall be made large enough so splitting does not occur during fabrication and not less than as follows (see Fig. 1):

- Thickness ≥ the smaller of 1½ in. (38 mm), or 2 dowel diameters
- Width ≥ the larger of 2 in. (50 mm) or 4 dowel diameters
- Length ≥ the larger of 2 in. (50 mm) or 4 dowel diameters

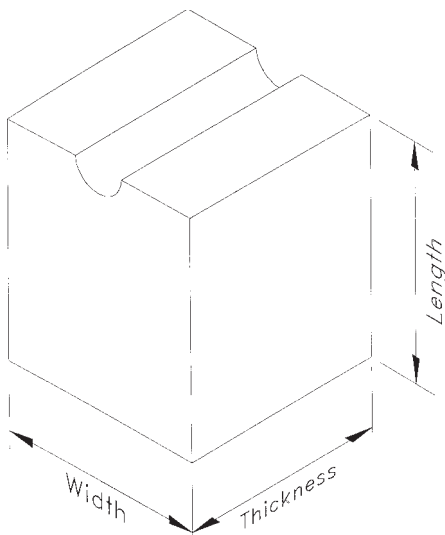

NOTE 1—Half of the fastener hole is produced by drilling oversized hole or by the method shown in Fig. 4.

FIG. 1 Specimen Configuration

NOTE 2—For driven dowels in species that tend to split, larger than minimum dimensions are recommended to prevent splitting during specimen preparation and testing.

8.2.2.1 For specimens that tend to split before the completion of the test, a full hole test configuration is allowed in Fig. 2. Minimum dimensions shall be made large enough so splitting does not occur during fabrication and not less than as follows (see Fig. 3):

- Thickness ≥ the smaller of 1½ in. (38 mm) or 2 dowel diameters
- Width ≥ the larger of 2 in. (50 mm) or 4 dowel diameters
- Length:
  - Loaded End ≥ the larger of 2 in. (50 mm) or 4 dowel diameters
  - Unloaded End ≥ the larger of 1 in. (50 mm) or 2 dowel diameters

8.2.3 For wood-base panel products, the minimum thickness shall be the thickness of the panel. Minimum width and length shall be the same as for solid wood.

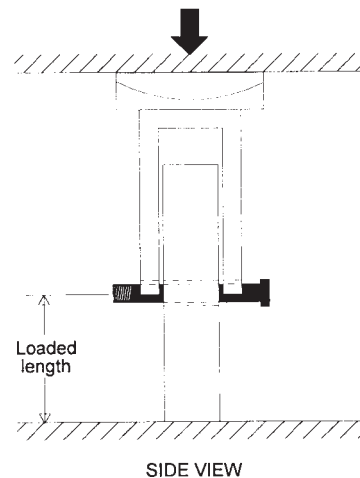
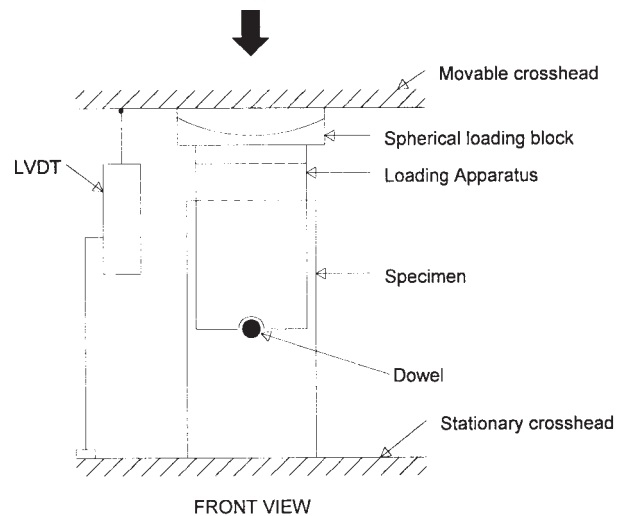

FIG. 2 Schematic of Testing Setup—Full Hole

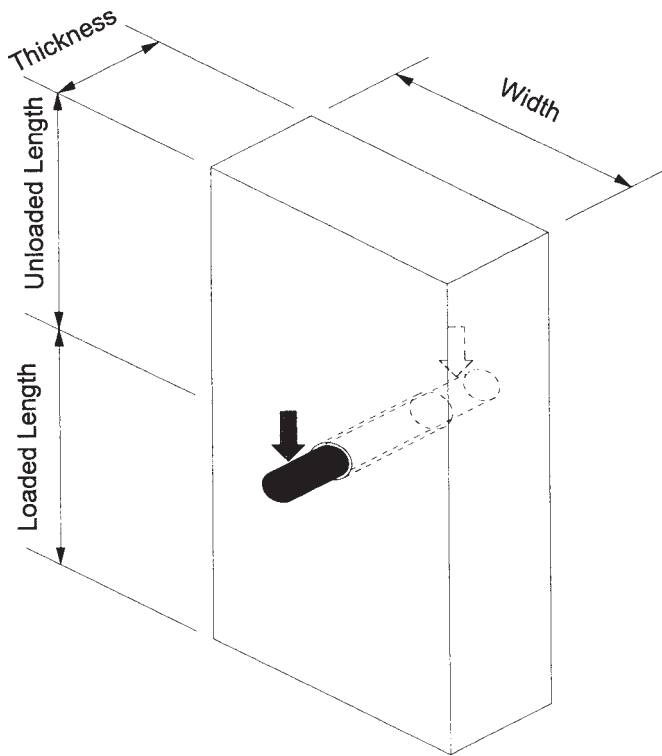

FIG. 3 Specimen Configuration—Full Hole

8.2.4 Fastener holes for fasteners that are installed in drilled holes that are equal to or greater than the fastener diameter shall be typical of those used in service. Drill the hole perpendicular and through the specimen and into an adjacent wood block to minimize splitting of the face where the drill bit exits. Then saw the specimen through the hole to produce a specimen with a half hole. For bolts, the hole shall be  $\frac{1}{16}$  in. (1.6 mm) larger than the bolt diameter. If other hole sizes are specified for the fastener, specimens shall have the specified hole size.

8.2.5 Fastener holes for fasteners that are driven or inserted by other means in holes that are smaller than the fastener diameter shall be typical of those in service. Use a pilot hole of the size specified for service conditions for the fastener. When pilot holes are used with nails, they shall be less than 75 % of the nail diameter (except wood members with specific gravity greater than 0.60 shall have lead holes less than 90 % of the nail diameter). The fastener shall be driven perpendicular to and through the test specimen and into an adjacent wood block to minimize spalling of the face where the fastener exits. If when removed, the fastener does not affect the hole surface, a half hole shall be produced by removing the fastener and sawing through the hole. When removed, if the fastener affects the hole surface, a half hole shall be produced by the procedure outlined in Fig. 4.

### 9. Conditioning

9.1 The tests shall be made with material conditioned to the appropriate conditions for the objectives of the testing program. Care shall be taken to maintain the desired condition of the material prior to and during testing, unless specified otherwise.

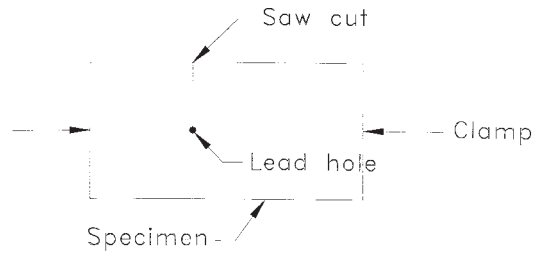

NOTE 1—The procedure is as follows:

- (1) Cut specimen at point where fastener is to be driven.
- (2) Clamp the two pieces together with sufficient pressure to maintain contact between adjoining faces during nailing.
- (3) Drill lead hole in seam of abutting pieces.
- (4) Drive fastener in lead hole.
- (5) Remove clamps and smaller piece.
- (6) The remaining piece is the test specimen with the fastener inserted in the hole.

FIG. 4 Means of Producing a Half-Hole Specimen When the Fastener Cannot Be Removed Without Affecting the Hole Surface

### 10. Procedure

10.1 *Half-Hole Testing Setup*—Place the dowel in the dowel hole. Place the specimen in the testing machine (see Fig. 5), so that a compressive load can be uniformly applied to the dowel along its length. A steel loading block of sufficient size to prevent bending of the dowel during loading shall be used between the dowel and movable crosshead.

NOTE 3—It may be necessary to provide lateral support to thin specimens loaded in compressions.

10.2 *Full-Hole Testing Setup*—Place the dowel in the dowel hole. Place the specimen in the testing machine so that a compressive load can be applied to the ends of the dowel using an assembly as shown in Fig. 2.

NOTE 4—It may be necessary to provide lateral support to thin specimens loaded in compression.

NOTE 5—If bending of the dowel is observed during loading, consideration of a half-hole test setup is recommended.

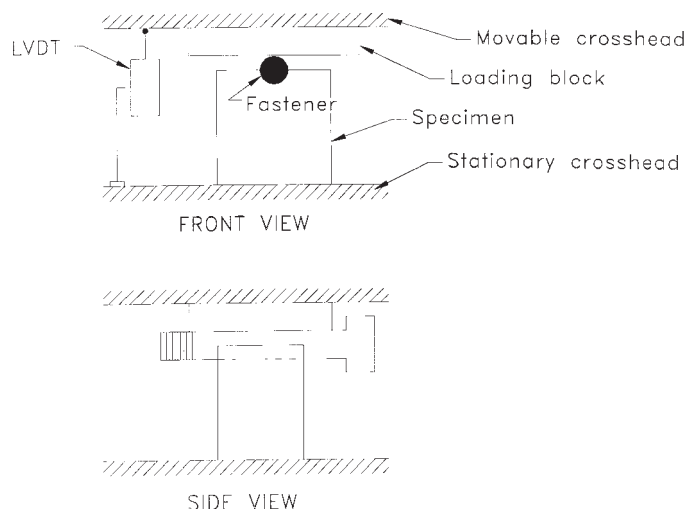

FIG. 5 Schematic of Testing Setup

NOTE 6—For full-hole bolt embedment specimens, experience has shown that a thickness of 2 to 3 bolt diameters (2 diameters  $\leq$  thickness  $\leq$  3 diameters) and an end distance equal to or greater than seven bolt diameters will provide embedment displacements at failure greater than the 5 % offset limit.

10.3 *Deformation Measurement*—The deformation of the fastener shall be taken as the movement of the moveable crosshead of the testing machine. Measure the movement with a linear variable differential transducer (LVDT), (see Fig. 5), or other suitable device.

NOTE 7—Equipment setup should be checked for tightness to ensure that there is no significant relaxation under load that would be erroneously recorded as dowel deformation.

10.4 *Rate of Testing*—Conduct the test to reach maximum load in 1 to 10 min. Record the rate of testing used.

NOTE 8—A constant rate of movement of the moveable crosshead of the testing machine of 0.04 in./min (1.0 mm/min)  $\pm$ 50 % usually permits reaching maximum load in the prescribed time.

10.5 *Testing*—Measure the deformation from the beginning of load application, and take readings at sufficiently frequent load intervals to permit establishment of a satisfactory load-deformation curve. Observe the general behavior of the specimen, and record the observations. Record the first relaxation of load indicated on the testing machine load scale, the mode of failure, maximum load, and other significant details. The test shall be terminated at an embedment of one half the fastener diameter or after maximum load has been reached.

10.6 *Minor Tests:*

10.6.1 Determine the oven-dry specific gravity and moisture content of each specimen tested. Procedures for determining these properties are given in Test Methods D 2395 and D 4442.

11. Interpretation of Results

11.1 *Yield Load*—The bearing yield load (see Fig. 6) is determined by the following procedure:

11.1.1 Fit a straight line to the initial linear portion of the load-deformation curve.

11.1.2 Offset this line by a deformation equal to 5 % of the fastener diameter.

11.1.3 Select the load at which the offset line intersects the load-deformation curve. In those cases where the offset line does not intersect the load-deformation curve, the maximum load shall be used as the yield load.

NOTE 9—Compute the dowel-bearing strength by dividing the yield load by the fastener diameter and the specimen thickness.

11.2 *Proportional Limit Load*—The proportional limit load (see Fig. 5) is the load at which the load-deformation curve deviates from a straight line fitted to the initial portion of the load-deformation curve.

12. Report

12.1 Report the following information:

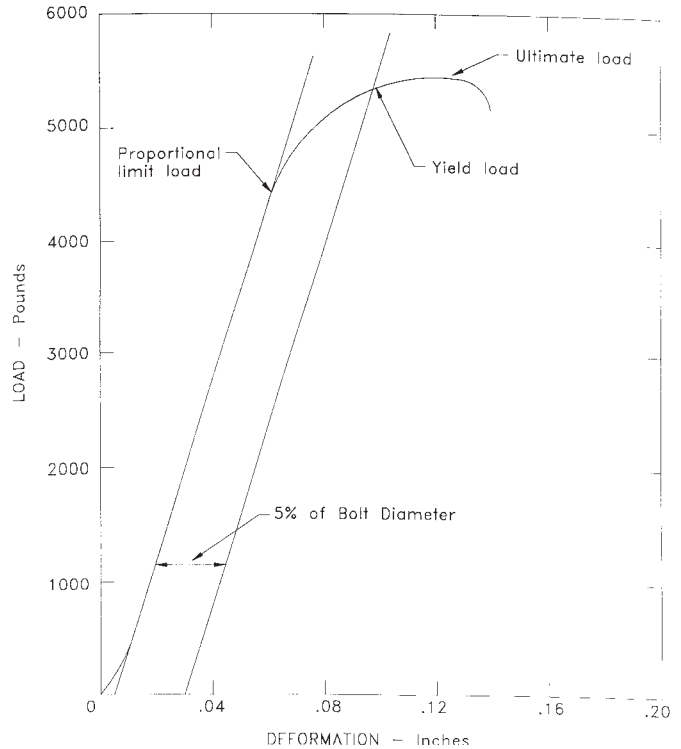

FIG. 6 Definition of Loads Obtained from the Load-Deformation Curve

- 12.1.1 Data on load deformation relationships, maximum load, and yield load,
- 12.1.2 Mode of failure,
- 12.1.3 Description of the wood species or wood-base product being tested,
- 12.1.4 Member dimensions, including length, width, thickness, and fastener hole diameter or lead hole diameter,
- 12.1.5 Details of loading procedure and deformation measurement system,
- 12.1.6 Number of replicate tests,
- 12.1.7 Oven-dry specific gravity,
- 12.1.8 Moisture content at time of test of each specimen,
- 12.1.9 Moisture content at time of fabrication of each specimen if different than moisture content at time of test,
- 12.1.10 Orientation of the wood grain with respect to the direction of the applied load,
- 12.1.11 Dimensions and other descriptive information about the fastener, and
- 12.1.12 Details of any deviation from the prescribed or recommended methods as outlined in this test method.

13. Precision and Bias

13.1 The precision and bias of this test method has not yet been determined.

14. Keywords

14.1 dowel-bearing strength; wood-base



## D 5764 – 97a (2002)

*ASTM International takes no position respecting the validity of any patent rights asserted in connection with any item mentioned in this standard. Users of this standard are expressly advised that determination of the validity of any such patent rights, and the risk of infringement of such rights, are entirely their own responsibility.*

*This standard is subject to revision at any time by the responsible technical committee and must be reviewed every five years and if not revised, either reapproved or withdrawn. Your comments are invited either for revision of this standard or for additional standards and should be addressed to ASTM International Headquarters. Your comments will receive careful consideration at a meeting of the responsible technical committee, which you may attend. If you feel that your comments have not received a fair hearing you should make your views known to the ASTM Committee on Standards, at the address shown below.*

*This standard is copyrighted by ASTM International, 100 Barr Harbor Drive, PO Box C700, West Conshohocken, PA 19428-2959, United States. Individual reprints (single or multiple copies) of this standard may be obtained by contacting ASTM at the above address or at 610-832-9585 (phone), 610-832-9555 (fax), or [service@astm.org](mailto:service@astm.org) (e-mail); or through the ASTM website ([www.astm.org](http://www.astm.org)).*