



Standard Test Method for Structural Performance of Sheet Metal Roof and Siding Systems by Uniform Static Air Pressure Difference¹

This standard is issued under the fixed designation E 1592; the number immediately following the designation indicates the year of original adoption or, in the case of revision, the year of last revision. A number in parentheses indicates the year of last reapproval. A superscript epsilon (ϵ) indicates an editorial change since the last revision or reapproval.

INTRODUCTION

Computations are the accepted method for determining the structural capacity of most metal products. However, some conditions are outside the scope of analysis by industry specifications.

Methods of computation and a discussion of these conditions are found in the following documents: AISI Specification for the Design of Cold-Formed Steel Structural Members and Load and Resistance Factor Specification for Cold-Formed Steel Structural Members and Aluminum Association Specifications for Aluminum Structures.

This test method is not to be considered as a wind design standard. It is a structural capacity test to determine the ability of a panel system (including attachments) to resist uniform static pressure. Actual wind pressure is nonuniform and dynamic. When these uniform static test results are used in conjunction with commonly recognized wind design standards, they will yield highly conservative results.

When additional fasteners are installed across panel flats at eaves, ridges, or reinforced end laps, the crosswise distortion is eliminated and *both flexural capacity and anchor-to-panel attachment strength can vary with the distance from such conditions*. This test procedure can be used to evaluate the strength of panels and attachments at any distance from end or edge perimeter conditions. The size of the specimen and limitations on air seals are designed to minimize any interference with the natural response of the panels under load.

1. Scope

1.1 This test method covers the evaluation of the structural performance of sheet metal panels and anchor-to-panel attachments for roof or siding systems under uniform static air pressure differences using a test chamber or support surface.

1.2 ~~The provisions of this test method is~~ are applicable to standing seam, trapezoidal, ribbed, or corrugated metal panels in the range of thickness from 0.012 to 0.050-in. (0.3 to 1.3-mm) ~~thickness and applies~~ apply to the evaluation of uniform pressure applied to single-skin construction or one sheet metal layer of multiple-skin construction. ~~It does~~ They do not cover requirements for the ~~evaluation~~ construction of a specimen to determine the load sharing that can occur with either composite or multiple-layer construction such as: 1) metal cladding over wood sheathing; or 2) field assemblies of insulation sandwiched between corrugated or formed metal panels.

1.3 Proper use of this test method requires knowledge of the principles of pressure and deflection measurement.

1.4 This test method describes optional apparatus and procedures for use in evaluating the structural performance of a given system for a range of support spacings or for confirming the structural performance of a specific installation.

1.5 The values stated in inch-pound units are to be regarded as the standard. The metric equivalents of inch-pound units are approximate.

1.6 *This standard does not purport to address all of the safety concerns, if any, associated with its use. It is the responsibility of the user of this standard to establish appropriate safety and health practices and determine the applicability of regulatory limitations prior to use. For specific precautionary statements, see Section 7.*

1.7 The text of this standard references notes and footnotes exclusive of those for tables and figures. These notes and footnotes provide explanatory material and shall not be considered as requirements of the standard.

¹ This test method is under the jurisdiction of ASTM Committee E-6 E06 on Performance of Buildings and is the direct responsibility of Subcommittee E06.57 on Performance of Metal Roofing Systems.

Current edition approved ~~Dec. April 10, 1998~~, 2001. Published ~~March 1999~~, July 2001. Originally published as E 1592 – 95. Last previous edition E 1592–98.

2. Referenced Documents

2.1 ASTM Standards:

A 370 Test Methods and Definitions for Mechanical Testing of Steel Products²

B 557 Test Methods for Tension Testing Wrought and Cast Aluminum- and Magnesium-Alloy Products³

2.2 Aluminum Association Standard:

Aluminum Formed-Sheet Building Sheathing Design Guide, Appendix B of *Specifications for Aluminum Structures*, Latest Edition⁴

2.3 AISI Standards:

Specification for the Design of Cold-Formed Steel Structural Members, Latest Edition⁵

2.4 Other Documents:

ASCE7 (Formerly ANSI A58.1) Minimum Design Loads for Buildings and Other Structures⁶

3. Terminology

3.1 Descriptions of Terms Specific to This Standard:

3.1.1 *anchor, n*—a fastener, bolt, screw, or formed device such as a clip that connects panels to the support structure.

3.1.2 *anchor failure, n*—any failure at the anchor device, including separation of the device from the panel, of the device itself, or of the connection to the structural support.

3.1.3 *crosswise restraint, n*—any attachment in the flat of a panel between structural elements that controls or limits pan distortion under pressure.

3.1.4 *failure, n*—fracture or disengagement of any of the components where the system is no longer capable of sustaining load, or the system no longer functions as a weathertight membrane.

3.1.5 *interior support, n*—any support other than those at either extreme in a series of supports for a continuous panel.

3.1.6 *pan distortion, n*—displacement under load of normally flat portions of a panel profile normal to the plane of the roof or wall surface.

3.1.7 *panel deflection, n*—displacement under load measured normal to the plane of the roof or wall surface of a longitudinal structural element as measured from a straight line between structural supports.

3.1.8 *permanent deformation, n*—the permanent displacement in any direction from an original position that remains after an applied load has been removed.⁷

3.1.9 *reference zero load, n*—nominal pressure applied to a specimen to provide a reference position free of variations from internal stresses or friction within the system assembly.

3.1.10 *rib spread, n*—panel distortion under load at the base of a rib or standing seam as measured crosswise to the rib in the plane of the roof or wall surface.

3.1.11 *span length, n*—the center-to-center distance between anchors or supports measured parallel to the longitudinal axis of the panel.

3.1.12 *specimen, n*—the entire assembled unit submitted for testing, as described in Section 8.

3.1.13 *specimen length, n*—the distance from center to center of the end supports; the sum of individual span lengths.

3.1.14 *structural element, n*—the width of a panel profile as measured between center lines of repeating longitudinal stiffeners for continuously supported panels in a positive load test or the width between anchor attachments to repeating stiffener elements in a negative load test.

3.1.15 *test load, n*—the difference in static air pressure (positive or negative) between the inside and outside face of the specimen, expressed in pounds-force per square foot (lbf/ft²) or pascals (Pa).

3.1.16 *test panel length, n*—specimen length plus overhangs.

3.1.17 *ultimate load, n*—the difference in static air pressure (positive or negative) at which failure of the specimen occurs, expressed in pounds-force per square foot (lbf/ft²) or pascals (Pa).

3.1.18 *unlatching failure, n*—disengagement of a panel seam or anchor that occurs in an unloaded assembly due to permanent set or distortion that occurred under a previous load condition.⁸

² *Annual Book of ASTM Standards*, Vol 01.03.

³ *Annual Book of ASTM Standards*, Vol 02.02.

⁴ Available from Aluminum Association, 900 19th Street, NW, Washington, DC 20006.

⁵ Available from American Iron and Steel Institute, 1101 17th Street NW, Suite 1300 Washington, DC 20036-4700.

⁶ Available from American Society of Civil Engineers, 345 East 47th Street, New York, NY 10017-2398.

⁷ Industry design procedures propose different factors of safety on yield and ultimate strength. Not all permanent distortion is harmful to the structural performance of the system. Only permanent distortion that interferes with the performance of the system is significant. The roof must still be capable of acting as a weather tight membrane.

⁸ This permanent set is not always detectable from readings taken normal to the panel.

3.1.19 *yield load, n*—that pressure at which deflection increases are no longer proportional to the increase in pressure. Yielding is not failure.⁹

3.1.20 *zero load, n*—the absence of air pressure difference across the specimen.

4. Summary of Test Method

4.1 This test method consists of the following: (1) sealing the test specimen into or against one face of a test chamber; (2) supplying air to, or exhausting air from, the chamber at the rate required to maintain the test pressure difference across the specimen; and (3) observing, measuring, and recording the deflection, deformations, and nature of any failures of principal or critical elements of the panel profile or members of the anchor system.

4.2 The increments of load application shall be chosen such that a sufficient number of readings will be obtained to determine the load deformation curve of the system.

4.3 End and edge restraint shall be representative of field conditions, and the unit shall contain sufficient individual components to minimize the effect of variations in material and workmanship.

5. Significance and Use

5.1 This test method provides a standard procedure to evaluate or confirm structural performance under uniform static air pressure difference. This procedure is intended to represent the effects of uniform loads on exterior building surface elements.

5.2 It is also permissible to develop data for load-span tables by interpolating between the test results at different spans.

NOTE 1—When applying the results of tests to determine allowable design loads by application of a factor of safety, bear in mind that the performance of a wall or roof and its components, or both, can be a function of fabrication, installation, and adjustment. The specimen must represent the actual structure closely. In service, the performance can also depend on the rigidity of supporting construction and on the resistance of components to deterioration by various causes, to vibration, to thermal expansion and contraction, etc.

6. Apparatus

6.1 The description of apparatus is general in nature; any equipment capable of performing the test procedure within the allowable tolerances is permitted. Major components are shown in Fig. 1.

6.2 *Test Chamber*—A test chamber, air bag, or box with an opening, a removable mounting panel, or one open surface in which or against which the specimen is installed. Provide at least two static pressure taps located at diagonally opposite corners to measure the chamber pressure such that the reading is unaffected by the velocity of the air supply to or from the chamber or any other air movement. The air supply opening into the chamber shall be arranged so that the air does not impinge directly on the test specimen with any significant velocity. A means of access into the chamber to facilitate adjustments and observations after the specimen has been installed is optional.

NOTE 2—The test chamber or the specimen mounting frame, or both, must not deflect under the test load in such a manner that the performance of the specimen will be affected. In general, select anchor support members sufficiently rigid that deflection under the test load will be negligible. It is desirable to be able to observe the fit of the plastic film against the specimen as well as the metal surface. When the specimen is tested with plastic film on either side, it is recommended that windows, lighting, or other methods be used to allow observation of the opposite side.

6.3 *Air System*—A compressed air supply, an exhaust system, or controllable blower is to be provided to develop the required air pressure difference across the specimen. The system shall maintain an essentially constant air pressure difference for the required test period.

NOTE 3—It is convenient to use a reversible blower or separate pressure and exhaust systems to provide the required air pressure difference so that different test specimens can be tested for the effect of positive pressure or the effect of suction (negative pressure) without reversing the position of the test specimen. The use of the same specimen for both positive and negative testing is outside the scope of this test method. If an adequate air supply is available, a completely airtight seal need not be provided around the perimeter of the test specimen and the mounting panel, although it is preferable. However, substantial air leakage will require an air supply of much greater capacity to maintain the required pressure differences.

6.4 *Pressure-Measuring Apparatus* —The devices to measure the test pressure difference shall operate within a tolerance of $\pm 2\%$ of the design pressure, or within 0.1 in. (2.5 mm) of water pressure (0.52 psf or 25 Pa) and be located as described in 6.1.

6.5 *Deflection and Distortion Measurement Precision:*

6.5.1 The means of measuring deflections of structural ribs between the reaction supports and movement of the ribs at the supports shall provide readings within a tolerance of ± 0.01 in. (0.25 mm).

6.5.2 The means of measuring pan distortion shall provide readings within a tolerance of $\pm 1/16$ in. (1.5 mm).

6.5.3 The means of measuring rib spread, when required, shall provide readings within a tolerance of $\pm 1/16$ in. (1.5 mm).

6.6 *Reading Locations:*

6.6.1 Support deflection gages or measuring devices so that readings are not influenced by movements of, or within, the specimen or member supports.

⁹ It is often impractical to take direct measurements on individual elements in an assembly of components. Readings made on a panel surface opposite an anchor clip include deflection of non-axial loads in the anchor base and panel profile as well as any slippage that occurs in the panel connection or between segments of a multiple-piece clip. They may decrease with increasing pressure and produce a bi-linear curve. Subsequent small-scale tests may be required to determine whether nonlinear deflection readings represent tolerable distortions that do not interfere with long-term anchor performance.

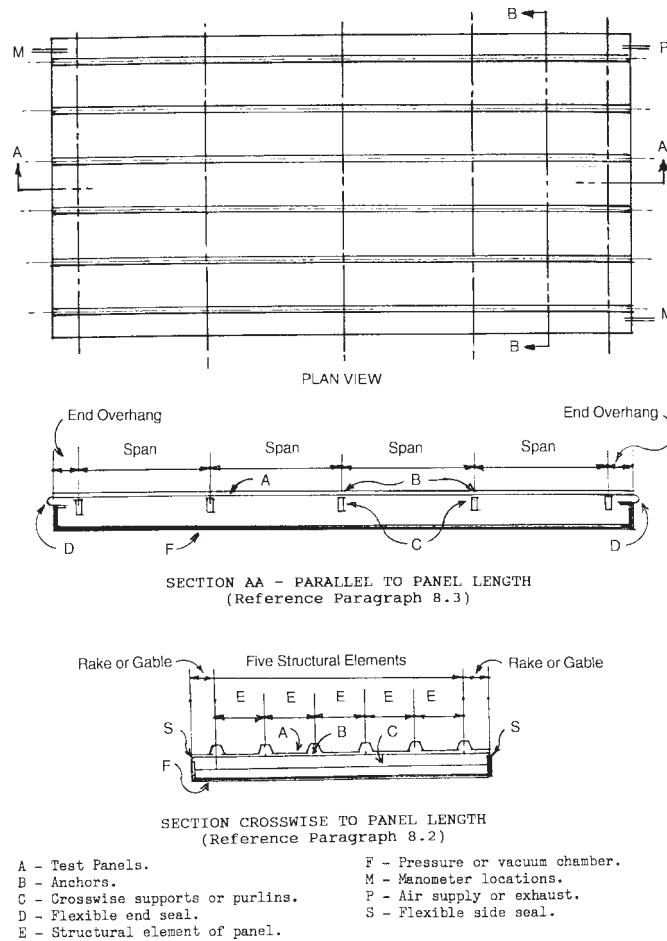

FIG. 1 Schematic of Test Apparatus

6.6.2 Measure the maximum mid-span and span end (at anchor support) deflections of at least one structural rib not influenced by the attachment or seal to the test chamber. Additional locations for deflection measurements, if desired, shall be stated by the specifier of the test.

6.6.3 Measure pan distortion in the middle of at least one panel flat (between structural elements) at a minimum of three locations.

6.6.4 Rib spread readings are optional for measuring panel distortion.

6.7 Reading Frequency:

6.7.1 In all cases readings shall be taken at initial zero or preload, at each increment of load, and again at the zero or preload to determine permanent set. See 10.2.4 regarding the selection of zero load.

7. Safety Precautions

7.1 Take proper precautions to protect the operating personnel and observers in the event of any failure.¹⁰

8. Test Specimen

8.1 The test specimens shall be of sufficient size to determine the performance of all typical parts of the system. Conditions of structural support shall be simulated as accurately as possible, and the full length and width, including overhangs, shall be loaded. All parts of the test specimen shall be full size, using the same materials, details, and methods of construction and anchorage as used on the actual building. Except for positive load as in 8.2.2, any partial width sheets shall not be considered in figuring specimen width.

8.2 *Specimen Width*— Edge seals shall not contain structural attachments that restrict deflection of the test panel any more than the normal gable condition.

8.2.1 For the evaluation of either bending capacity or anchor to panel attachment strength under negative load, the specimen width shall contain not less than three full panels and five structural elements (see Fig. 2).

¹⁰ At the pressures used in this test method, considerable energy and hazard are involved. In cases of failure, the hazard to personnel is less with an exhaust system, as the specimen will tend to blow into the test chamber rather than out. Do not permit personnel in such chambers during the application of a pressure difference.

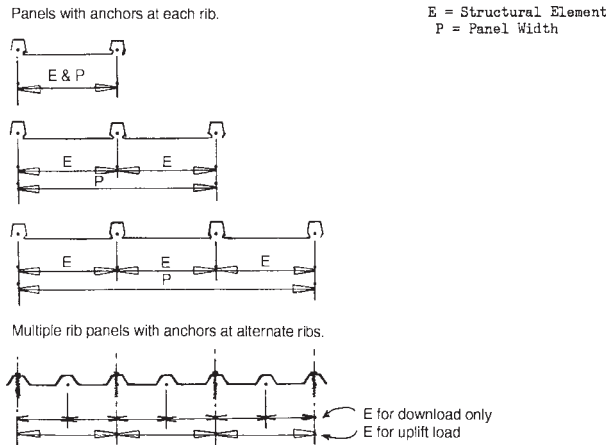

FIG. 2 Examples of Structural Elements and Panel Width for Different Profiles

TABLE 1 Minimum Number of Equal Spans To Comply With 8.3^A

Ends with Crosswise Restraint	2	10
Span length	Number of equal spans	
12 ft-0 in. or more	2	22
12 ft-0 in. (3.7 m) or more	2	2
below 12 ft to 8 ft-0 in.	3	22
below 12 ft (3.7m) to 8 ft-0 in. (2.4 m)	3	2
below 8 ft-0 in.	4	32
below 8 ft (2.4 m) to 6 ft-0 in. (1.8 m)	4	3
below 6 ft-0 in.	5	32
below 6 ft (1.8 m) to 5 ft-0 in. (1.5 m)	5	3
below 5 ft-0 in.	24/L	33
below 5 ft (1.5 m) to 4 ft-0 in. (1.2 m)	24/L	3
below 4 ft-0 in.	24/L	43
below 4 ft (1.2 m) to 3 ft-0 in. (0.9 m)	24/L	4
below 3 ft-0 in.	24/L	4
below 3 ft (0.9 m) to 2 ft-0 in. (0.6 m)	24/L	4
below 32 ft-6 in.	24/L	54
below 32 ft-6 in.	24/L	5
below 2 ft-6 in. to 2 in. 0 in.	24/L	5
below 2 ft (0.6 m)	24/L	5
below 2 ft	24/L	1 + 8/L
		10/L

^A Count fractional spans as whole numbers, that is, 24/5 = 4.8 = 5 spans.

8.2.2 For the evaluation of panel bending capacity in resisting positive pressure, the specimen width shall be as specified in 8.2.1 or be not less than 40 % of the clear span and include not less than four structural elements with not less than one half the flat distance to the next adjacent nonincluded parallel rib, corrugation, or stiffener on each side.

8.3 *Specimen Length*— For negative (uplift) load tests (or any form of loading that tends to push panels away from the crosswise support), unless the test represents the full length used, the specimen length shall be sufficient to ensure that end seals or attachments do not restrict panel movement at the area under investigation.

8.3.1 For the evaluation of anchor to panel strength free of end influence, the arbitrary minimum specimen length, (exclusive of the end overhangs) when both ends have crosswise restraint, is 24 ft (7.3 m). Shorter lengths are acceptable when only one end having has crosswise restraint and when the unrestrained end is a minimum of 8 ft (2.4 m) from at least one row of interior anchors. When both ends are free of crosswise restraint, the minimum specimen length is 10 ft (3 m)¹¹ (see Table 1). When crosswise restraint is removed from both ends, the normal failure mechanism is the anchor connection to the seam. Other modes of failure or performance must be evaluated using one or both ends restrained.

8.3.2 For the evaluation of anchor to panel strength, the results are deemed to be free of end influence when measurements of panel distortion indicate that the sample is outside the effect of the end condition as follows:

8.3.2.1 When maximum mid-span panel distortion readings of an identical 24-ft (7.3-m) panel do not exceed (within the tolerance of the measurement) the maximum readings on the shorter setup; or

¹¹ The arbitrary length minimums in this section are based on tests of aluminum panels with structural elements 8 to 18-in. (203 to 457-mm) apart in nominal thicknesses from 0.0165 to 0.040 in. and of steel panels 12 to 24-in. (305 to 610-mm) apart in nominal thicknesses from 30 gage (0.0157 in.) to 22 gage (0.0336 in.). Additional testing or data (such as that listed in 8.3.2) may be required to validate appropriate lengths for products significantly outside these limits. Note that tests with both ends open do not necessarily reflect the panel bending capacity near end conditions.

8.3.2.2 When maximum mid-span panel distortion readings do not exceed (within the tolerance of the measurement) the mid-span distortion readings at least 4 ft (1.2 m) on both sides of at least one purlin.

8.3.3 For positive load tests, where the panels are supported to resist the applied load at each structural element in the mid-roof area as well as at the ends, the specimen length is not restricted.

8.4 Structural supports used in the test shall be of sufficient strength and rigidity to minimize deflection of the assembly. For supports used in positive pressure tests, due consideration must be given to the width of the support that is in contact with the panel.¹²

8.5 End conditions that simulate eave or ridge flashing situations in which the panel terminates at or slightly beyond the purlin are considered to have crosswise restraint and influence distortion for some distance along the length of the panel. An open-end condition is one without crosswise restraint.

8.5.1 It is permissible to reinforce open-end conditions to prevent non-typical failures of clip to panel attachment or of web buckling caused by proximity of the free edge to the support. Acceptable reinforcement includes longitudinal stiffeners in the flats to prevent buckling of flats. Also acceptable are seam fasteners at the ends of ribs to prevent un-seaming from the free end. Seam reinforcers shall not be located more than 4 in. from the end of the test panel. The reinforcement shall not restrict crosswise panel deformation nor cause the end seal to pull away from the pan as panels distort under load.

8.6 Overhangs at end conditions shall not exceed one-quarter of the span.

9. Calibration

9.1 The calibration of liquid column manometers, dial gages, and graduated scales or tape measures is not required for each test.¹³

10. Procedure

10.1 Omit from the test specimen any undue influence from gravity, sealing, or construction material that does not occur during actual installation.

10.1.1 If the test panel orientation is either inverted or vertical, a gravity correction, based upon the weight of the panel itself, shall be made in the determination of the allowable superimposed loading. Tests run in an inverted position shall include data from pressure reversal or an upright specimen to demonstrate that unlatching will not occur in the normal orientation.

10.1.2 For negative load tests, the interior side of the specimen shall face the higher pressure.¹⁴ Support and secure the specimen by the same number and type of anchors normally used for installing the unit on a building, or if this is impractical, by the same number of other comparable fasteners located in the same way as in the intended installations.

10.1.3 If air leakage through or around the test specimen is excessive, tape or plastic film is acceptable to block any cracks and joints through which the leakage is occurring. Tape or film shall not be used to span a joint where it restricts differential movement between adjoining members. This caution applies specifically to the inside face of standing seam panels which tend to spread apart under pressure. See the instructions for proper film placement in the annex.

10.1.4 In cases in which it will not affect the results, it is permissible to apply a single thickness of polyethylene film no thicker than 6 mils (0.006 in.) (0.15 mm). The technique of application is important so that full load is permitted to be transferred to the specimen and the membrane does not prevent movement or failure of the specimen. Apply the film loosely, with extra folds of material at each corner and at all offsets and recesses including the perimeter of the test specimen. The film shall not span any joint that will tend to separate under pressure. When the load is applied, there shall be no fillet caused by tightness of plastic film that will have a significant effect on the results.¹⁵

10.2 *Procedure*—The following procedure is designed to produce a minimum of six points on the load-deflection curve. For precision in determination of the yield and ultimate strength, smaller increments are permitted to obtain additional points at the discretion of the test operator.

10.2.1 Check the specimen for proper adjustment, and close all vents in pressure-measuring lines.

10.2.2 Install the required deflection-measuring devices at their specified locations.

10.2.3 At each increment of load, maintain pressure for not less than 60 s and until the dial gages indicate no further increase in deflection.

10.2.4 Apply a nominal initial pressure equal to at least four times but not more than ten times the dead weight of the specimen. If the applied loads are in the same direction as gravity on the test specimen, remove this pressure and record the initial readings

¹² This test method is under the jurisdiction of ASTM Committee E06 on Performance of Buildings and is the direct responsibility of Subcommittee E06.57 on Performance of Metal Roofing Systems.

Current edition approved April 10, 2001. Published July 2001. Originally published as E 1592 – 95. Last previous edition E 1592–98.

¹³ Water density varies less than 0.5 % over the temperature range from 40 to 90°F (4.4 to 32°C) and the length of metal measurement devices varies even less. Persistent differences in pressure readings at opposite ends of a test chamber indicate uneven air flow within the chamber or leaks in the lines to the manometers. If reducing the rate of increase does not allow the pressure to stabilize, the test readings are suspect. Leaks in manometer lines produce readings that are less than the actual pressures.

¹⁴ In positive load tests, when the specimen is mounted with the exterior side up, it is common practice to apply a preload to set the specimen against the supports. This load is removed, and the gages are set to zero. In negative load tests, it is desirable to maintain a low pressure at zero reading that will take the slack out of the system for accurate readings of permanent set. However, it is important to reach a zero load condition to permit the system to unlatch if it is susceptible to permanent local distortion. If negative load tests are run on an inverted specimen, gravity will possibly prevent this.

¹⁵ Failure of the plastic film by stretching between its supports indicates that it was restraining the movement of the test setup.

at zero load. If applied loads are not in the same direction as gravity, use this nominal pressure as the reference zero and record the initial readings.¹⁵

10.2.5 Unless otherwise specified, the first increment of load shall be nominally equal to one third the anticipated ultimate load.

10.2.6 Reduce the pressure difference to zero and, after a recovery period of not more than 5 min at zero load, increase the pressure to reference zero (if used instead of zero) and take readings to determine permanent deformation for the first increment of load.

10.2.7 Proceed as above with successive increments that do not exceed one sixth the maximum specified test load until failure or the specified ultimate load is reached.¹⁶

10.2.8 When the behavior of the specimen under load indicates that failure is imminent, it is permissible to remove the deflection measuring devices and to increase the load continuously until failure. In such cases, the yield point must be assumed to have been reached at or before the last recorded load.

10.2.9 After initial failure of one or more connections that leaves the majority of the specimen intact, it is permissible to provide external support to prevent further displacement of those locations and continue the loading to develop additional data.¹⁷

11. Report

11.1 Report the following information:

11.1.1 Date of the test and issue of the report. State the location of the facility, name of the testing agency (if any), and names of the specific observers of the test. Cite the qualifications of any independent observers called in to certify the test procedure or results.

11.1.2 Identification of the specimen (manufacturer, source of supply, dimensions, model types, materials, and other pertinent information).

11.1.3 Detailed drawings of the specimen and test fixture, showing the dimensions of section profiles, purlin location, measurement locations, panel arrangement, installation and spacing of anchorage, sealants, and perimeter construction details. Note any modifications made on the specimen, including reinforcement in accordance with 10.2.9, to obtain the reported values, on the drawings.

11.1.4 Measured thickness and tensile yield strength of the material used in the test panels. Mechanical properties and thickness shall be measured after the removal of coatings in accordance with the appropriate standards for the material used, that is, Test Methods A 370 for steel and Method B 557 for aluminum. These values will be used to verify conformity with the product specification or make any required adjustment of allowable capacity within the range of a material specification and shall be made in accordance with the appropriate ASTM standard for the material involved.

11.1.5 Tabulation of the number of test load increments, zero load value and pressure differences exerted across the specimen at load increments, pertinent deflections at these pressure differences, and permanent deformations at locations specified for each specimen tested.

11.1.6 Plot of deflections and permanent set related to pressures applied.

11.1.7 Duration of the test loads, including incremental loads.

11.1.8 Record of visual observations of performance and description of the location and type of failure experienced.

11.1.9 When the tests are made to check conformity of the specimen to a particular specification, an identification or description of that specification.

11.1.10 Statement that the tests were conducted in accordance with this test method or a full description of any deviations from this test method.

11.1.11 Statement that the panel and sealing method was observed by the testing engineer with comments concerning whether tape or film, or both, were used to seal against air leakage, and whether, in the judgment of the test engineer, the tape or film could have influenced the results of the test.

11.2 If several essentially identical specimens of a component are tested, report the results for all specimens, with each specimen being identified properly, particularly with respect to distinguishing features or differing adjustments. A separate drawing for each specimen will not be required if all differences between them are noted on the drawings provided.

12. Precision and Bias

12.1 This is a new procedure, and precision and bias of the test method is to be determined.

13. Keywords

13.1 air bags; air seals; anchor strength; crosswise distortion; deflection; flexural capacity; rib spread; sheet metal roof and siding; single skin construction; standing seam; static air pressure; structural performance; test chamber; trapezoidal, ribbed, and corrugated panels; unlatching failure

¹⁶ Counting the zero reading, the minimum number of loads called for will provide six points on the load deflection curve. For greater precision, especially at higher ultimate load values, the load increments may be smaller. Except for plotting convenience, they need not be exactly equal; if the pressure overshoots the target value, it should be maintained at the high value and readings taken for that pressure. During each load cycle the test specifier or engineer has the option to record deflection at the level of the previous increment before proceeding to the next higher load. This will assure that unlatching has not occurred.

¹⁷ Individual attachment failures may occur before panel buckling. In tests with one open end, clips may have higher strength within the influence of the crosswise end restraint at the other end. Ribs at failed clips may be braced to allow higher pressures.

ANNEX

(Mandatory Information)

A1. PROPER USE OF FILM AND AIRBAGS

A1.1 When plastic film is used to seal joints or transmit air pressure to the surface of a roof specimen at any point other than a restrained end condition, it must contact all surfaces of the panel and must not interfere with the movement of adjacent parts. In an uplift test, friction of film that bridges the gap at the base of a standing seam as in Fig. A1.1 prevents lateral movement and yields non-conservative results whether it be a flat film sealed at the edges or an air bag.

A1.2 Longitudinal pleats that fit up into the rib on both sides of a clip, as in Fig. A1.2, ensure full contact and eliminate restraint.

A1.3 Multiple longitudinal air bags wider than the panel module as in Fig. A1.3 provide the same effect without the need to perforate the air bag with the anchor fastener. Where either of these interfere with proper clip engagement, all seals must be limited to the perimeter of the test specimen.

A1.4 Multiple crosswise air bags as in Fig. A1.4 do not make full contact and will hamper panel distortion. Plastic film must always lie between the panel and the crosswise support structure to provide continuous longitudinal contact. Other methods of sealing that demonstrate distortion equivalent to air pressure without film are acceptable.

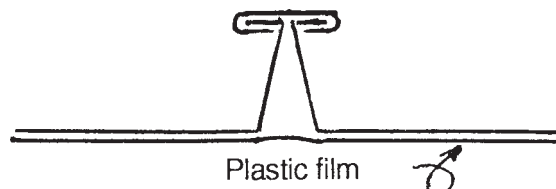

FIG. A1.1 Improper Seal Where Film Spans Crevice at Base of Rib

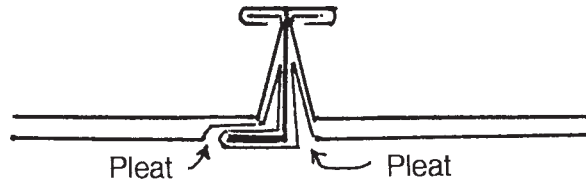

FIG. A1.2 Pleats Make Contact with Metal Panel on Both Sides of Clips

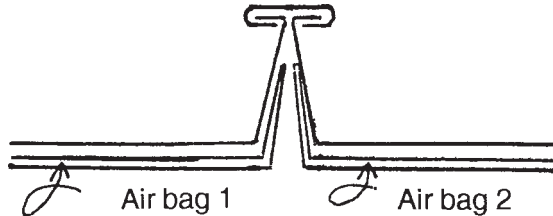

FIG. A1.3 Proper Seal at Rib with Multiple Longitudinal Air Bags

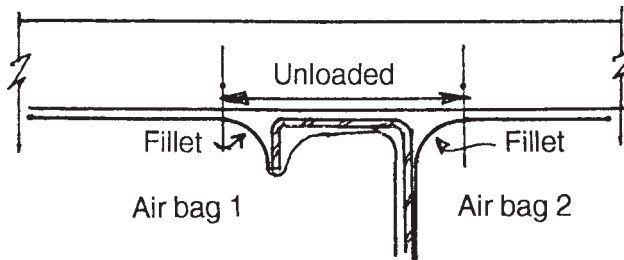

FIG. A1.4 Improper Use of Multiple Air Bags Between Supports

APPENDIX

(Nonmandatory Information)

X1. GENERAL DISCUSSION

X1.1 Analysis and interpolation of test results should be by a qualified design professional. Wind forces on building surfaces are complex, varying with wind direction, height above ground, building shape, terrain, surrounding structures, and other factors. For design purposes, wind loads are represented by static uniform loads. Other loads represented as static uniform loads include the weight of the building element itself and other permanent building loads. Live loads represent multiple combinations of temporary concentrated and uniform loads that are superimposed on building elements during the life of a structure. Snow loads are distributed loads of variable magnitude imposed on roofs that are affected by drifts, appendages, parapets, setbacks, etc.

X1.2 Since this test method is based on static pressure difference, individuals specifying design loads must translate anticipated values from internal and external pressure coefficients into a uniform air pressure difference. Some sources are the applicable building code, ASCE 7, or recognized model test procedures.

X1.3 Both the specifier of this test method and anyone interpreting the results should understand that static pressure does not cover all aspects of dynamic wind loading and that building code values for minimum design wind pressures do not deal with the load sharing that can occur in multiple-layer construction. Any evaluation of test results on multiple-layer specimens should consider the possibility that crosswise or lengthwise flow of air within layers can reduce or eliminate load sharing in actual service.

X1.3.1 For example, spaces in trapezoidal ribs and around blocks of rigid insulation laid between purlins on top of a vapor retarder can allow sufficient lateral air flow under dynamic conditions to invalidate the results of a test in which air pressure exerted against a vapor retarder is transmitted to the panels only by displacement of the insulation. On the other hand, in service, a rigid pressure-tight deck tends to restrict a tight fitting metal roof covering from carrying the full negative pressure. The determination of design or service pressures for roof coverings as compared to the total roof structure is outside the scope of this test method.

X1.4 When product design is based on tests, metal industry specifications (see 2.2 and 2.3) require that the results be adjusted for the minimum anticipated properties (gauge and thickness) of the material to be furnished. The factor of safety therefore need

cover only variations in workmanship and anticipated service load. For roll-formed panels, tests on production material often differ considerably from those on brake-formed prototypes. Industry standards also require that tests cover the extremes of span and load. They allow interpolation between the results for like failure modes but generally prohibit extrapolation to spans or pressures beyond the range of the tests.

X1.5 Unless the test is being run to confirm computations, industry standards (see 2.2 and 2.3) require that the average of either two or three tests be used to substantiate performance for design purposes. When used for the uplift capacity of anchors, the procedure described in this test method is believed to meet the intent of this requirement with a single specimen for several reasons: (1) the minimum size contains sufficient identically loaded components to provide the statistical equivalent of four samples; (2) the use of two manometers affords a measure of confidence in the readings that is greater than an individual reading; and (3) a failure reading is the minimum rather than the average because any further reloading of the specimen will either develop incipient failures from the original load or go to higher values.

X1.6 The analysis of test results should consider the possible effect of specimen size on the mode of failure. Both ends open will produce the most severe condition for an anchor to panel connection but not necessarily the most severe for bending capacity. Under negative air pressure, some shapes assume an arched configuration that is stronger than the less distorted profile near an eave or ridge.

X1.7 Factors of safety are higher for connections than for panel strength. Test pressures may reach ultimate panel capacity before anchor loads became critical. Tests may be required at several spans to evaluate both conditions.

ASTM International takes no position respecting the validity of any patent rights asserted in connection with any item mentioned in this standard. Users of this standard are expressly advised that determination of the validity of any such patent rights, and the risk of infringement of such rights, are entirely their own responsibility.

This standard is subject to revision at any time by the responsible technical committee and must be reviewed every five years and if not revised, either reapproved or withdrawn. Your comments are invited either for revision of this standard or for additional standards and should be addressed to ASTM International Headquarters. Your comments will receive careful consideration at a meeting of the responsible technical committee, which you may attend. If you feel that your comments have not received a fair hearing you should make your views known to the ASTM Committee on Standards, at the address shown below.

This standard is copyrighted by ASTM International, 100 Barr Harbor Drive, PO Box C700, West Conshohocken, PA 19428-2959, United States. Individual reprints (single or multiple copies) of this standard may be obtained by contacting ASTM at the above address or at 610-832-9585 (phone), 610-832-9555 (fax), or service@astm.org (e-mail); or through the ASTM website (www.astm.org).