



# Standard Test Methods for Strength of Anchors in Concrete and Masonry Elements<sup>1</sup>

This standard is issued under the fixed designation E 488; the number immediately following the designation indicates the year of original adoption or, in the case of revision, the year of last revision. A number in parentheses indicates the year of last reapproval. A superscript epsilon ( $\epsilon$ ) indicates an editorial change since the last revision or reapproval.

*This standard has been approved for use by agencies of the Department of Defense.*

## 1. Scope

1.1 These test methods cover procedures for determining the static, seismic, fatigue and shock, tensile and shear strengths of post-installed and cast-in-place anchorage systems in structural members made of concrete or structural members made of masonry. Only those tests required by the specifying authority need to be performed.

1.2 These test methods are intended for use with such anchorage devices designed to be installed perpendicular to a plane surface of the structural member.

1.3 Whereas combined tension and shear as well as torsion tests are performed under special conditions, such tests are not covered in the methods described herein.

1.4 While individual procedures are given for static, seismic, fatigue and shock testing, nothing herein shall preclude the use of combined testing conditions which incorporate two or more of these types of tests, (such as seismic, fatigue and shock tests in series), since the same equipment is used for each of these tests.

1.5 *This standard does not purport to address all of the safety concerns, if any, associated with its use. It is the responsibility of the user of this standard to establish appropriate safety and health practices and determine the applicability of regulatory limitations prior to use.*

## 2. Referenced Documents

### 2.1 ASTM Standards:

- E 4 Practices for Force Verification of Testing Machines<sup>2</sup>
- E 171 Specification for Standard Atmospheres for Conditioning and Testing Flexible Barrier Materials<sup>3</sup>
- E 468 Practice for Presentation of Constant Amplitude Fatigue Test Results for Metallic Materials<sup>2</sup>
- E 575 Practice for Reporting Data from Structural Tests of

Building Constructions, Elements, Connections, and Assemblies<sup>4</sup>

## 3. Terminology

### 3.1 Definitions of Terms Specific to This Standard:

3.1.1 *adhesive anchor*—a post-installed anchor that derives its holding strength from the chemical compound between the wall of the hole and the anchor rods. The materials used include epoxy, cementitious material, polyester resin, and other similar types.

3.1.2 *anchor spacing*—the distance between anchors measured centerline to centerline, in mm (in.); also, the minimum distance between reaction points of the test frame.

3.1.3 *cast-in-place anchor*—an anchor that is installed prior to the placement of concrete and derives its holding strength from plates, lugs, or other protrusions that are cast into the concrete.

3.1.4 *displacement*—movement of an anchor relative to the structural member. For tension tests, displacement is measured along the axis of the anchor, and for shear tests, displacement is measured perpendicular to the axis of the anchor, in mm (in.).

3.1.5 *edge distance*—side cover distance or the distance from the centerline of an anchor to the nearest edge of a structural member, in mm (in.); also, minimum distance from the centerline to the test frame.

3.1.6 *embedment depth*—distance from the test member surface to the installed end of the anchor, in mm (in.), prior to the setting of the anchor.

3.1.7 *expansion anchor*—a post-installed anchor that derives its holding strength through a mechanically expanded system which exerts forces against the sides of the drilled hole.

3.1.8 *fatigue test*—a laboratory test that applies repeated load cycles to an anchorage system for the purpose of determining the fatigue life or fatigue strength of that system.

3.1.9 *LVDT*—a linear variable differential transformer used for measuring the displacement or movement of an anchor or anchor system.

<sup>1</sup> These test methods are under the jurisdiction of ASTM Committee E06 on Performance of Buildings and are the direct responsibility of Subcommittee E06.13 on Structural Performance of Connections in Building Construction.

Current edition approved May 10, 2003. Published June 2003. Originally approved in 1976. Last previous edition approved in 1996 as E 488 – 96.

<sup>2</sup> *Annual Book of ASTM Standards*, Vol 03.01.

<sup>3</sup> *Annual Book of ASTM Standards*, Vol 15.09.

<sup>4</sup> *Annual Book of ASTM Standards*, Vol 04.11.

3.1.10 *post-installed anchor*—an anchor that is installed after the placement and hardening of concrete.

3.1.11 *run-out*—a condition where failure did not occur at a specified number of load cycles in a fatigue test.

3.1.12 *safe working loads*—the allowable or design load obtained by applying factors of safety to the ultimate load of the anchorage device, kN (lbf).

3.1.13 *seismic test*—a laboratory test that applies load cycles of varying magnitude and frequency to an anchorage system for the purpose of simulating a seismic event (earthquake).

3.1.14 *shear test*—a test in which an anchor is loaded perpendicular to the axis of the anchor and parallel to the surface of the structural member.

3.1.15 *shock test*—a laboratory test that simulates shock loads on an anchorage system by the application of a short duration external load.

3.1.16 *static test*—a test in which a load is slowly applied to an anchor according to a specified rate such that the anchor receives one loading cycle.

3.1.17 *structural member*—the material in which the anchor is installed and which resists forces from the anchor.

3.1.18 *tensile test*—a test in which an anchor is loaded axially in tension.

3.1.19 *undercut anchor*—a post-installed anchor that derives its holding strength from an expansion of an embedded portion of the anchor into a portion of the hole that is larger in diameter than the portion of the hole between the enlarged section and the surface of the structural member. The enlarged diameter section of the hole is predrilled or enlarged by an expansion process during setting of the anchor.

### 3.2 Symbols:

$h_{ef}$	= effective depth of embedment of an anchor in mm (in.).
$F_s$	= safe working load in kN (lbf).
$h$	= thickness of the structural member in mm (in.).
$h_v$	= anchor embedment depth in mm (in.).
$s$	= anchor spacing in mm (in.) measured centerline to centerline.
$c$	= edge distance in mm (in.) measured from centerline of anchor to edge.
$d$	= nominal anchor diameter in mm (in.).
$\Delta_T$	= uncorrected displacement for tension tests in mm (in.).
$\Delta_S$	= uncorrected displacement for shear tests in mm (in.).
$A_N$ and $B_N$	= instrument readings at a given load in mm (in.).
$A_I$ and $B_I$	= initial instrument readings in mm (in.).
$\Delta_T$	= average displacement at maximum load for tension tests in mm (in.).
$\Delta_S$	= average displacement at maximum load for shear tests in mm (in.).
$n$	= number of test samples.
$N_T$	= total number of load cycles in tension fatigue test.

$N_S$	= total number of load cycles in shear fatigue test.
$\bar{N}_T$	= average number of load cycles in tension fatigue test.
$\bar{N}_S$	= average number of load cycles in shear fatigue test.
$\Delta_{FT}$	= displacement of anchor occurring at maximum load for tension fatigue test mm (in.).
$\Delta_{FS}$	= displacement of anchor occurring at maximum load for shear fatigue test mm (in.).
$A_{fu}$ and $B_{fu}$	= maximum displacement instrument readings for fatigue tests mm (in.).
$A_{fi}$ and $B_{fi}$	= initial displacement instrument readings for fatigue tests mm (in.).
$\bar{\Delta}_{FT}$	= average maximum displacement for tension fatigue tests mm (in.).
$\bar{\Delta}_{FS}$	= average maximum displacement for shear fatigue tests mm (in.).

## 4. Significance and Use

4.1 These test methods are intended to provide data from which applicable design data and specifications are derivable for a given anchorage device used in a structural member of concrete, masonry and related products and for qualifying anchors or anchorage systems.

4.2 The test methods shall be followed to ensure reproducibility of the test data.

## 5. Apparatus

### 5.1 Equipment:

5.1.1 *Laboratory*—Suitable equipment shall be used to perform tests to generate data required to publish load tables or to obtain listings from approval agencies, building officials, etc. Calibrated electronic load and displacement measuring devices which meet the sampling rate of loading specified herein shall be used. The equipment shall be capable of measuring the forces to an accuracy within  $\pm 1\%$  of the anticipated ultimate load, when calibrated in accordance with Practices E 4. The load and displacement measuring devices shall be capable of providing data points at least once per second in order to produce continuous load versus displacement curves. A minimum of 120 data points per instrument shall be obtained and recorded for each individual test. The readings shall be obtained prior to reaching peak load. The instruments shall be positioned to measure the vertical movement of the anchor with respect to points on the structural member in such a way that the instrument is not influenced during the test by deflection or failure of the anchor or structural member. The testing device shall be of sufficient capacity to prevent yielding of its various components and shall ensure that the applied tension loads remain parallel to the axes of the anchors and that the applied shear loads remain parallel to the surface of the structural member during testing.

5.1.2 *Field Tests*—Suitable equipment shall be used to perform tests required to verify correct installation or provide proof loads on anchors installed at a specific job site. Calibrated load cells which meet the specified rate of loading given herein shall be used. The equipment shall be capable of measuring the forces to an accuracy within  $\pm 2\%$  of the

applied load, when calibrated in accordance with Practices E 4. For field tests which require displacement measurements, use either manually read dial gages or electronic load and displacement measuring devices, provided they are capable of generating a minimum of 50 data points prior to reaching peak load. For field tests requiring displacement measurements, the instrument(s) shall be positioned to measure the vertical movement of the anchor with respect to points on the structural member in such a way that the instrument is not influenced during the test by deflection or failure of the anchor or structural member. The testing device shall be of sufficient capacity to prevent yielding of its various components and shall ensure that the applied tension loads remain parallel to the axes of the anchors and that the applied shear loads remain parallel to the surface of the structural member during testing.

5.2 *Tension Test*—Examples of suitable systems for applying tension pull-out forces are shown in Figs. 1 and 2 in which a single anchor specimen is shown. The test system support shall be of sufficient size to prevent failure of the surrounding structural member. The loading rod shall be of such size to develop the ultimate strength of the anchorage hardware with minimal elastic elongation and shall be attached to the anchorage system by means of a connector that will minimize the direct transfer of bending stress through the connection.

5.3 *Shear Test*—Examples of suitable systems for applying shear forces are shown in Figs. 3 and 4 in which a single anchor specimen is shown. The components of the test fixture shall be of sufficient size and strength to prevent their yielding during ultimate capacity tests on the anchorage system.

5.4 *Loading Plate*—The thickness of the loading plate in the immediate vicinity of the test anchor shall be equal to the nominal bolt diameter to be tested,  $\pm 1.5$  mm ( $\pm 1/16$  in.), representative of a specific application.

5.4.1 The hole in the loading plate shall have a diameter 1.5 mm  $\pm$  0.75 mm (0.06 mm  $\pm$  0.03 in.) greater than the test anchor. The initial shape of the hole in the loading plate shall correspond to that of the anchor cross section and shall be

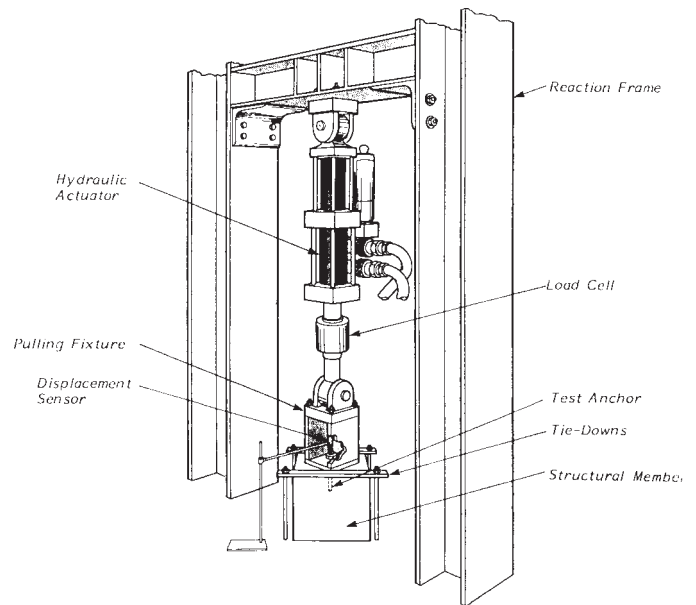

FIG. 2 Typical Seismic Tension Test Arrangement

maintained throughout all tests. Worn or deformed holes shall be repaired. Insert sleeves of the required diameter shall be periodically installed in the loading plate to meet these requirements.

5.4.2 For shear testing, the contact area between the loading plate through which the anchor is installed and the structural member shall be as given in Table 1, unless otherwise specified. The edges of the shear loading fixture shall be chamfered or have a radius to prevent digging in of the loading plate.

5.5 *Anchor Displacement Measurement*— For anchor tests that require displacement measurements, the displacement measurements shall be made using LVDT device(s) or equivalent which provide continuous readings with an accuracy of at least 0.025 mm (0.001 in.). Dial gages having an accuracy of

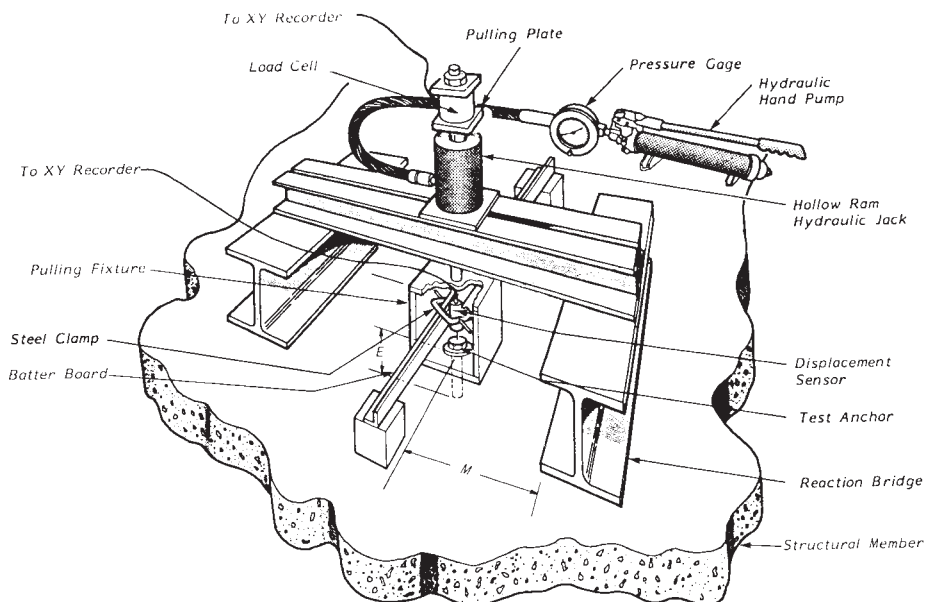

FIG. 1 Typical Static Tension Test Arrangement

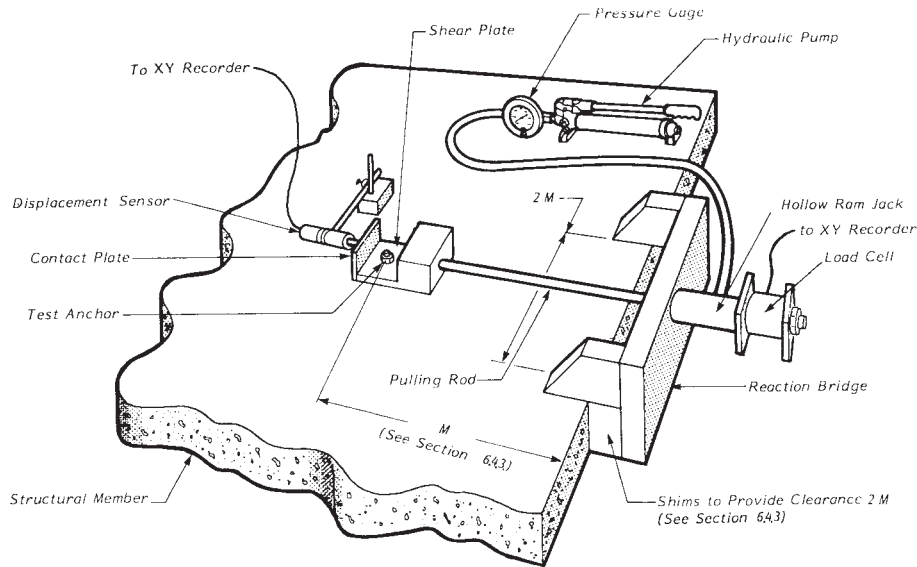

FIG. 3 Typical Method of Applying Shear Loads to Anchors Attached to Structural Members—Direct Loading Method

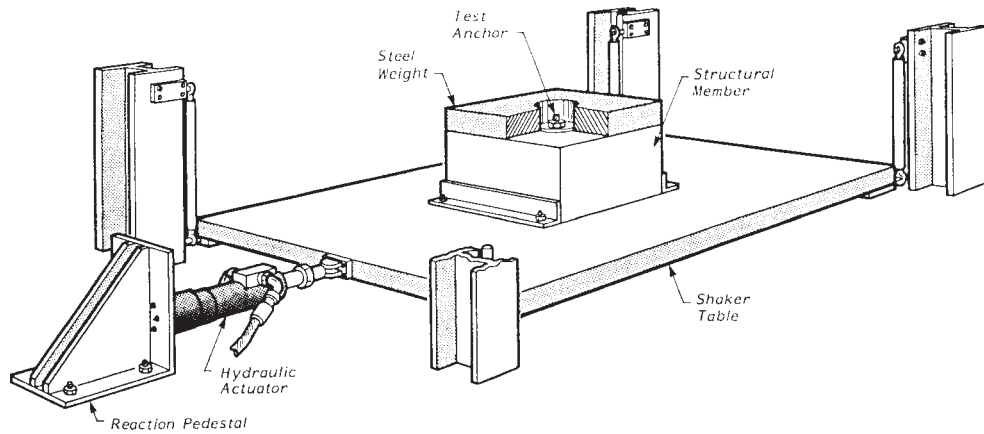

FIG. 4 Typical Seismic Shear Test Arrangement—Indirect Loading Method

TABLE 1 Shear Loading Plate Bearing Area as a Function of Anchor Diameter

Anchor Diameter, mm (in.)	Shear Loading Plate Contact Area, cm <sup>2</sup> (in. <sup>2</sup> )
<10 (<3/8)	50–80 (8.00–12.40)
10–<16 (3/8 –<5/8)	80.01–120 (12.41–18.60)
16–<22 (5/8 –<7/8)	120.01–160 (18.61–24.80)
22–<51 (7/8 –<2)	160.01–260 (24.81–40.30)
>51 (>2)	260.1–400 (40.31–62.00)

0.025 mm (0.001 in.) are permitted in field testing or for general tests where precise displacement measurements are not required.

5.5.1 Tension Test:

5.5.1.1 Single Anchor—The displacement measuring device(s) shall be positioned to measure the vertical movement of the anchors with respect to points on the structural member in such a way that the device is not influenced during the test by deflection or failure of the anchor or structural member.

5.5.1.2 Group of Anchors—Displacement measurements shall be made on all anchors or group of anchors tested

simultaneously except that only one set of instruments needs to be used for a group of anchors tested as a closely spaced cluster. Displacement measurements as described in 5.5 include components of deformation not directly associated with displacement of the anchor relative to the structural member. Include components of deformation such as elastic elongation of the loading rod anchor stem, deformation of the loading plate, sleeves, shims, attachment hardware, and local structural member material. Deduct all of the elongations from these sources from the total displacement measurements by using supplementary measuring devices or calibration test data for the installed test set-up with rigid specimen replacing the anchor to be tested. The displacement to be used for the evaluation of the findings is the average displacement indicated by both instruments mounted symmetrically equidistant from the centroid of the cluster as shown in Fig. 5.

5.5.2 Shear Test—The displacement measuring device(s) shall be positioned to measure displacement in the direction of the applied load. The device shall be placed on the structural member to allow the sensing element to bear perpendicularly on the anchor or on a contact plate located on the loading plate

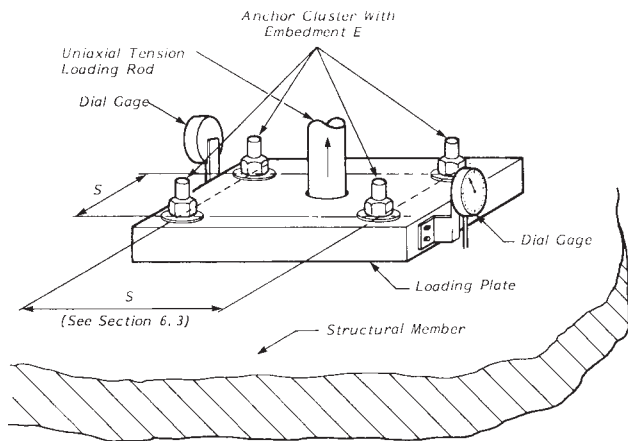

**FIG. 5 Typical Method of Applying a Test Load to a Cluster of Anchors in the Test Area of a Structural Member**

as shown in Fig. 3 or other method which prevents extraneous deflections. For tests on clusters of anchors, the instrument shall lie on a plane through the axis of the shear loading rod or plate. An extension of the axis of the shear loading rod or plate shall pass through the centric axis of the cluster of anchors.

**6. Test Specimens**

6.1 *Anchorage System*—The anchorage system shall be representative of the type and lot to be used in field construction and shall include all accessory hardware normally required for its use, that is, all attachment hardware.

6.2 *Anchor Installation*—Install the anchorage device in accordance with the manufacturer’s procedures and tools, or, where specific deviation is justified, in accordance with good field methods.

6.3 *Anchor Placement*—Individually test all anchors as specified in the test program. The anchors shall be tested at distances equal to or greater than those given in Table 2. The distances in Table 2 are not intended for design of attachments. Table 2 test support requirements are not prohibited from being reduced for bonded anchors with embedments equal to or greater than 20 anchor diameters. For anchors intended to be field-installed at spacings less than specified in Table 2 in groups of two or more, test at the intended spacings or edge distances per the requirements of 8.3 at the selected spacing and edge distance intervals to assign reduction factors.

6.4 *Structural Member*—The structural member in which the anchor is to be embedded shall be representative of the materials and configuration intended for field use. The structural member is not prohibited from being steel-reinforced. The location and orientation of any reinforcement embedded in

concrete or masonry members shall be evaluated. The overall size of the test specimen shall not be reduced unless the requirements in 6.4.1-6.4.3.1 are met.

6.4.1 The depth of the structural member shall be equal to the minimum member depth specified by the manufacturer. The structural member shall be at least 1.5  $h_{ef}$  in thickness so long as the depth is suitable for normal installation of the anchor and does not result in premature failure of either the structural member or anchor, unless the specific test application requires a lesser thickness. The structural member will act as a beam if the spacing between reaction supports is greater than the thickness of the member. A structural member with a thickness of at least 1.5  $h_{ef}$  will minimize bending during the application of the tensile load to the test anchor. In general, the thickness of the test member shall be equal to the minimum member depth specified by the manufacturer.

6.4.2 The length and width of the structural member shall ensure that no shear or tension failure spall intersects either the outside edges of the structural member or the bearing contact points of the test frame. The overall size of the test specimen shall only be reduced when the minimum requirements in 6.4.1 are met.

6.4.3 *Surface Finish*—The surface of the structural member where the loading fixture or loading plate bears on the member shall be a form-work or steel-trowel finish unless otherwise specified.

6.4.3.1 For static shear tests, a sheet of tetrafluoroethylene (TFE), polytetrafluoroethylene (PTFE), fluorinated ethylene propylene (FEP), or perfluoroalkoxy (PFA) of  $0.5 \pm 0.1$  mm ( $0.020 \pm 0.004$  in.) thickness and corresponding to the area required according to Table 1 shall be placed between the shear plate and the surface of the structural member.

**7. Conditioning**

7.1 *Specimen Conditioning and Curing*—When aging, seasoning, or curing conditions affect the performance and capacity of the installed anchor, take appropriate measures to age, season, or cure the installed anchoring system in accordance with appropriate procedures prior to testing. Describe such conditions in detail. Cast-in-place concrete, grout-set, and epoxy-set anchors are some examples of anchorage systems that require provisions for aging or curing.

7.2 *Specimen Moisture and Temperature*—When moisture and temperature conditions affect the performance of the anchorage system, they shall be kept constant during the testing of the anchorage system. The choice of the controlled conditions shall simulate the conditions under which the anchors will be used. Simulate field moisture and temperature conditions or use standard conditions of 23°C (73°F) and 50 % relative humidity, as provided in Specification E 171. Testing shall begin only after the test specimens have reached at least an appropriate stable condition with regard to temperature and moisture content.

**8. Static Tests**

8.1 *Equipment*—Use any suitable testing or loading system specified in the Apparatus section.

8.2 *Number of Test Specimens*—For determining the average tension or shear resistance, a minimum of five anchors per

**TABLE 2 Minimum Clearance Requirements for Test Equipment Supports**

Adhesive Anchors		All Other Anchors	
Spacing between Test Supports	Minimum Distance to Edge or Test Frame	Spacing between Test Supports	Minimum Distance to Edge or Test Frame
Tension Loads			
$2.0h_{ef}$	$1.0h_{ef}$	$4.0h_{ef}$	$2.0h_{ef}$
Shear Loads			
$4.0h_{ef}$	$2.0h_{ef}$	$4.0h_{ef}$	$2.0h_{ef}$

size shall be tested and the five test results averaged. Where steel failures occur, only a minimum of three anchors per size shall be tested and the three test results averaged.

8.3 *Number of Test Specimens for Statistical Data*—For determining statistical data, such as coefficient of variation or spacing and edge-distance reduction factors (with a  $\pm 10\%$  accuracy), a minimum number of tests ( $n$ ) shall be performed in accordance with Table 3.

8.3.1 This procedure shall be repeated for each variation in anchor type, size, embedment depth, and location. This procedure shall also be repeated for each variation in the structural member.

8.4 *Static Test Procedure:*

8.4.1 *Tension Test:*

8.4.1.1 Position the loading system, in such a way that the placement of the test system supports meet the requirements of Table 2 (see Figs. 1 and 2). Position the loading device in such a way that it is centered over the anchor to be tested. Provide uniform contact between the surface of the structural member and the support system. In the final alignment of the support system, ensure that the forces to be applied through the loading rod are perpendicular to the surface of the structural member section. The amount of torque or pretension applied to the anchor by the attaching nut or locking device shall be uniform for each series of tests.

8.4.1.2 Position and attach the loading rod so that the load is applied through the center of a single anchor, or through the centroid of a cluster of anchors. Whenever a loading plate is required in the testing of a cluster of anchors, ensure uniform loading of the individual anchors of the cluster.

8.4.2 *Shear Test:*

8.4.2.1 Position the loading system in such a way that the placement of the test system supports meet the requirements of Table 2 (see Fig. 3). A reaction bridge is not required along the edge of the structural member if the edge distance is larger than  $4 h_{ef}$  in all directions.

8.4.2.2 Position and fasten the structural member in the support system in such a way that the test surface of the structural member is parallel to the loading plate and the axis of the pulling rod. Place the loading plate-rod assembly onto the structural member and secure it in place with the appropriate nut or other locking device typically used for the particular anchor installation to be tested. The amount of force exerted on the loading plate by the attaching nut or locking device shall be uniform for each series of tests performed.

8.5 *Initial Load*—Apply an initial load up to 5% of the estimated maximum load capacity of the anchorage system to be tested, in order to bring all members into full bearing.

8.6 *Rate of Loading*—Two loading rates are given. For tests that require precise anchor load-displacement data for calculating stiffness or assessing proper functioning, the continuous

load application method is required. The first method requires a continuous increase in load up to failure or up to a maximum specified load or displacement. The second is a step-loading method in 15% increments of the expected ultimate load.

8.6.1 *Continuous Load Application*—Apply loading to the anchor at a uniform rate that will produce a failure as defined in the Failure Criteria section. A loading rate of 25 to 100% of the ultimate anchor capacity per minute shall be used except that a minimum 1-min total test time and a maximum 3-min total test time is allowed when the test equipment provides accurate recording of load and displacement readings.

8.6.2 *Incremental Load Application*—In step loading during sustained constant-level load increments up to a maximum load, each increment load shall not exceed more than 15% of the estimated maximum test load and shall be maintained for a 2-min period. Plot the initial and 2-min readings of the measurement devices in the form of load-displacement curves. Maintain complete load-displacement records throughout the test or plot after completion of the test. The data records shall include a time record of the beginning and end of each increment of constant load.

8.6.3 *Load Application for a Given Period*—If application of a given load is required for a certain period, such as 24 h, deformation readings shall be taken at the beginning, during, and end of the period to allow the satisfactory plotting of a time-displacement curve for the complete period.

8.7 *Calculations:*

8.7.1 *Load-Displacement Data:*

8.7.1.1 Determine the uncorrected displacements  $\Delta_T$  and  $\Delta_S$  at any given load for an individual test in the following manner:

For tension tests:

$$\Delta_T = \frac{1}{2} (A_N - A_I + B_N - B_I) \quad (1)$$

For shear tests:

$$\Delta_S = A_N - A_I \quad (2)$$

where:  $A_N$  and  $B_N$  are instrument readings at the given load, and  $A_I$  and  $B_I$  are initial instrument readings.

8.7.1.2 Obtain the corrected displacement by plotting the uncorrected displacement versus the applied loads and extrapolating a smooth curve through the data points back to zero load. The corrected displacement at maximum or at any other test load is observed from the plot relative to the adjusted zero-load displacement value.

8.7.1.3 Obtain the average displacement at maximum ( $\Delta_T$  or  $\Delta_S$ ) or any other load for each test series as the arithmetic mean of all individual displacement determinations at a given load in a given series.

**9. Seismic Tests**

9.1 These tests demonstrate the capability of an anchor to withstand a simulated seismic event.

9.2 *Equipment*—Any suitable testing or loading system shall be used as provided for in the Apparatus section.

9.3 *Number of Test Specimens*—For determining the average tension or shear capability of the anchorage system, perform at least five tests per anchor size and type unless otherwise specified.

**TABLE 3 Size for Statistical Evaluation of Test Data**

Coefficient of Variation, %	Minimum Test Sample Size Required, $n$
Up to 12	5
12 to 15	10
>15	30

#### 9.4 Seismic Test Procedure:

9.4.1 *Tension Test*—Position the loading system as described in 8.4.1.

9.4.2 *Rate and Level of Loading*—Apply test loads and cycles in accordance with a specified program to simulate seismic requirements.

##### 9.4.3 *Shear Test*:

9.4.3.1 *Shear Test Direct-Loading Procedure*—Position the loading system in accordance with 8.4.2 as shown in Fig. 3.

9.4.3.2 *Shear Test Indirect Loading Procedure*—A structural member with a predrilled hole or an installed anchor is secured to the shaker table with bearing angles and tie-down bolts. The steel weight is then set over the hole or the installed anchor. This weight is secured to the structural member by the anchor (see Fig. 4).

##### 9.4.4 *Rate of Loading*:

9.4.4.1 *Direct Loading and Rate Procedure*—Apply test loads and cycles in accordance with a specified program to simulate seismic requirements.

9.4.4.2 *Indirect Loading Rate Procedure*—Use the seismic shear test specified program given by the specifying authority. Inspect the anchor for failure or any suspected damage after each set of cycles.

9.4.4.3 *Instrumentation for Indirect Shear Test*—Accelerometers attached to the shaker table, structural member, and steel weight are used to monitor the input and output acceleration-level forces.

9.4.4.4 Once the cyclic test has been completed, the anchor shall be subjected to a shear test to determine its residual strength in accordance with the Apparatus and the Failure Criteria section, if required.

### 10. Fatigue Tests

10.1 *Equipment*—Any testing machine as described in the Apparatus section shall be used provided the requirements of specific loading rate and accuracy are met. The configuration of the test systems shall be such that no resonant vibrations are produced during the tests.

10.2 *Number of Test Specimens*—The number of test specimens shall be based on the purpose of the test. If the objective is to obtain runout at or below the endurance limit (that is,  $2 \times 10^6$  cycles) at a given load, then three samples that reach runout are sufficient. If the test objective is to determine the maximum load that will reach runout (the endurance limit), then tests in accordance with Practice E 468 shall be performed.

10.3 *Fatigue Test Procedure*—Apply the specified fatigue test program, including the method, load levels, frequency, and number of cycles.

10.4 Once the cyclic test has been completed, apply a static tension load in accordance with the section on Static Tests to determine its residual strength and failure mode in accordance with the section on Failure Criteria.

### 11. Shock Test

11.1 *Equipment*—This test method is not intended to prohibit the use of any testing or loading device which provides the performance described in the Apparatus section.

11.2 *Number of Test Specimens*—The purpose and type of the shock test will determine the number of test specimens.

11.2.1 If the purpose is to determine if an anchorage system will withstand a specified shock load (magnitude and duration), at least three anchors shall be tested per anchor size at a given load and duration.

11.2.2 If the purpose is to determine the maximum shock loading an anchorage system is capable of withstanding without failure, a suitable test method such as a staircase method shall be used to obtain an anchorage failure. Three separate anchor tests at a given load without failure shall be sufficient to establish the maximum shock capacity of the anchorage system.

##### 11.3 *Shock Test Procedure*:

11.3.1 *Tension Test*—Position the loading system as described in 8.4.1.

11.3.2 *Shear Test*—Position the loading system as described in 8.4.2.

11.4 *Rate of Loading Tension or Shear*—Apply a specified number of shocks to each anchor in a triangular (ramp) loading rate with a total application of 30 ms per shock, or as otherwise specified. After application of the shock loads, the anchors shall be tensile tested in accordance with the Static Tests section to measure residual static tensile capacity, if required.

### 12. Failure Criteria

12.1 *Load and Displacement at Failure*—Determine the maximum test load and the corresponding displacement for each assembly tested.

12.2 *Failure Modes*—Failure occurs by one or more of the following modes:

12.2.1 Failure of the structural member in a shear-cone mode.

12.2.2 Failure of the structural member with or without cracking that radiates outward from the location of the anchorage device, resulting in a pullout of the anchor.

12.2.3 Pullout of the anchor.

12.2.4 Failure of the bond between the anchor and the structural member. Displacement failure is evidenced by continuous displacement associated with a constant or decreasing applied load.

12.2.5 The fracture of any component of the anchoring device including hardware accessories shall constitute failure. Some anchorage systems require deformation to become effective. This provision does not apply to that deformation.

### 13. Report

13.1 Report the applicable information listed in Practice E 575, all information pertinent to the type of test performed (static, seismic, fatigue or shock, cracked or uncracked concrete), and specifically include the following:

13.1.1 Dates of test and date of report;

13.1.2 Test sponsor and test agency;

13.1.3 Identification of anchors tested: manufacturer, model type, material, finish, shape, dimensions, and other pertinent information, such as cracks and other defects;

13.1.4 Description of the anchorage system tested and physical description of the structural member, including dimensions, installed reinforcing, etc.;



13.1.5 Detailed drawings or photographs of test specimens before and after testing if not fully described otherwise;

13.1.6 Physical strength properties of the structural member into which the anchor(s) are embedded including mix design of the concrete, aggregate type, 28-day compressive strength, compressive strength at time of test, and age of the structural member at time of test;

13.1.7 Description of the procedure, tools and materials used to install the anchorage system, and any deviation from those specified;

13.1.8 Age, in hours or days of anchorage system, since installation, where applicable;

13.1.9 Moisture condition, at time of test of structural member in percent of oven-dry weight where applicable. The moisture content of the structural member at time of test is determined by several methods, including drying of small samples to constant weight or use of moisture meters;

13.1.10 Temperature conditions at time of installation and at time of testing and any other temperature experience which affects anchor performance;

13.1.11 Embedment depth of the installed anchors in mm (in.);

13.1.12 Amount of torque applied to the anchor prior to testing;

13.1.13 Description of test method and loading procedure used and actual rate of loading;

13.1.14 Number of replicate specimens tested;

13.1.15 Individual and average maximum load values, in kN (lbf), per embedded anchor, standard deviations and coefficients of variation, where applicable;

13.1.16 Individual and average displacement values at ultimate loads ( $\Delta_T$ ,  $\Delta_S$ , or both), in mm (in.) and standard deviations, or where appropriate load versus displacement curves, as plotted directly, or as reprinted from data acquisition systems;

13.1.17 Description of the nature and type of failure exhibited by each anchor tested, including where appropriate, individual and average fatigue life values ( $\bar{N}_T$ ,  $\bar{N}_S$ ) in numbers of fatigue load cycles or the runout number of fatigue load cycles;

13.1.18 Photographs, sketches, or word descriptions of the failure modes observed;

13.1.19 Summary of findings; and

13.1.20 Listing of observers of tests and signatures of responsible persons.

#### 14. Precision and Bias

14.1 No statement is made on the precision or bias of these test methods, since the test results indicate only whether there is conformance to given criteria and since no generally accepted method for determining precision and bias of these test methods is currently available. The information provided herein on the specimens, instrumentation, and procedures makes the results intractable to calculation of meaningful values by statistical analysis for precision and bias at this time.

#### 15. Keywords

15.1 anchors; cast-in-place anchors; chemical anchors; concrete elements; expansion anchors; fatigue; masonry elements; post-installed anchors; seismic; shock; static; tensile/shear strengths; test methods

*ASTM International takes no position respecting the validity of any patent rights asserted in connection with any item mentioned in this standard. Users of this standard are expressly advised that determination of the validity of any such patent rights, and the risk of infringement of such rights, are entirely their own responsibility.*

*This standard is subject to revision at any time by the responsible technical committee and must be reviewed every five years and if not revised, either reapproved or withdrawn. Your comments are invited either for revision of this standard or for additional standards and should be addressed to ASTM International Headquarters. Your comments will receive careful consideration at a meeting of the responsible technical committee, which you may attend. If you feel that your comments have not received a fair hearing you should make your views known to the ASTM Committee on Standards, at the address shown below.*

*This standard is copyrighted by ASTM International, 100 Barr Harbor Drive, PO Box C700, West Conshohocken, PA 19428-2959, United States. Individual reprints (single or multiple copies) of this standard may be obtained by contacting ASTM at the above address or at 610-832-9585 (phone), 610-832-9555 (fax), or service@astm.org (e-mail); or through the ASTM website (www.astm.org).*