

This document is not an ASTM standard and is intended only to provide the user of an ASTM standard an indication of what changes have been made to the previous version. Because it may not be technically possible to adequately depict all changes accurately, ASTM recommends that users consult prior editions as appropriate. In all cases only the current version of the standard as published by ASTM is to be considered the official document.



---

**Designation: E 661 – 88 (Reapproved 1997)**



**Designation: E 661 – 03**

# Standard Test Method for Performance of Wood and Wood-Based Floor and Roof Sheathing Under Concentrated Static and Impact Loads <sup>1</sup>

This standard is issued under the fixed designation E 661; the number immediately following the designation indicates the year of original adoption or, in the case of revision, the year of last revision. A number in parentheses indicates the year of last reapproval. A superscript epsilon (ε) indicates an editorial change since the last revision or reapproval.

## INTRODUCTION

During construction and occupancy of a building, floor and roof sheathing are subjected to concentrated loads that frequently govern the thickness required. Static loads may simulate either foot traffic, or loads from fixtures, when applied through loading disks of appropriate size. Impact loads will occur during construction and also in service.

Roof sheathing and subflooring are likely to be critical in strength or stiffness, or both, under foot traffic and construction loads, while single-layer floors are generally critical under fixture loads, foot traffic, and in-service impact loads. Subfloors, like single floors, must also support fixture loads, but they will have an additional layer of material, such as underlayment above, which will help to distribute concentrated loads.

<sup>1</sup> This test method is under the jurisdiction of ASTM Committee E06 on Performance of Buildings and is the direct responsibility of Subcommittee E06.11 on Horizontal and Vertical Structures/Structural Performance of Completed Structures.

Current edition approved ~~May 27, 1988~~; Oct. 1, 2003. Published ~~September 1988~~; November 2003. Originally published as E 661–78; approved in 1978. Last previous edition approved in 1997 as E 661 – 788 (1997).

## 1. Scope

1.1 This test method covers procedures for determining the resistance to deflection and damage of floor and roof sheathing used in site-built construction subjected to concentrated static loads as well as impact loads from nonrigid blunt objects. It is applicable to wood and wood-based panels and boards, but is not intended to cover profiled metal decks, nor precast or cast-in-place slabs. Surface indentation is not evaluated separately from deflection.

1.2 Three applications are covered: roof sheathing, subfloors, and single floors. Roof sheathing is tested in both a dry and a wet condition, while subfloors and single floors are both tested in a dry condition, as well as a condition of having dried out after being wet. These moisture conditions are those commonly experienced with site-built construction.

NOTE 1—Where it is anticipated that sheathing will be subjected only to dry conditions during construction and use, or else to greater moisture exposure than is indicated in 6.7.3.2, the corresponding exposure conditions may be modified by agreement between the interested parties. For example, shop-built construction may be tested dry only, although the possibility of exposure to high humidity or leaks and flooding during use should be considered.

1.3 The values stated in metric (SI) units are to be regarded as the standard.

1.4 *This standard does not purport to address all of the safety concerns, if any, associated with its use. It is the responsibility of the user of this standard to establish appropriate safety and health practices and determine the applicability of regulatory limitations prior to use.*

## 2. Referenced Documents

2.1 *ASTM Standards:* <sup>2</sup>

~~D 1517 Definitions of Terms~~ 1517 Terminology Relating to Leather

E 575 Practice for Reporting Data from Structural Tests of Building Constructions, Elements, Connections, and Assemblies

E 631 Terminology for Building Construction

2.2 *Federal/Other Standards:*

Fed. Spec. V-T-291E(1) Linen Thread<sup>3</sup>

<sup>2</sup> For referenced ASTM standards, visit the ASTM website, [www.astm.org](http://www.astm.org), or contact ASTM Customer Service at [service@astm.org](mailto:service@astm.org). For Annual Book of ASTM Standards, Vol 15.04, volume information, refer to the standard's Document Summary page on the ASTM website.  
~~Annual Book of ASTM Standards, Vol 04.07.~~

### 3. Summary of Test Method

3.1 Roof and floor sheathing specimens are subjected Terminology

3.1 See Terminology E 631 for terms related to concentrated loads applied through a 76-mm (3-in.) or a 25-mm (1-in.) diameter loading disk, depending on the intended use and the properties to be evaluated. They are also subjected to the impact of a shot-filled drop bag. Specimens are tested in a horizontal position, mounted on fully supported framing members and with loads applied to the top surface near an edge, or at a location determined to be more vulnerable. Any support framing may be used that is representative of the anticipated service, as the framing is not considered a major test variable. this standard.

### 4. Significance Summary of Test Method

4.1 Roof and Use

4.1 The procedures outlined will provide data that can be used floor sheathing specimens are subjected to evaluate the structural performance, under concentrated loads; applied through a 76-mm (3-in.) or a 25-mm (1-in.) diameter loading disk, depending on the intended use and floor sheathing, separate from the effects of properties to be evaluated. They are also subjected to the framing, under simulated conditions representative impact of those in actual service.

4.2 The procedures a shot-filled drop bag. Specimens are tested in a horizontal position, mounted on fully supported framing members and with loads applied to the top surface near an edge, or floor sheathing materials installed directly at a location determined to framing. They are not intended for the evaluation be more vulnerable. Any support framing may be used that is representative of the framed assembly anticipated service, as the framing is not considered a whole. major test variable.

### 5. Significance and Use

5.1 The procedures outlined will provide data that can be used to evaluate the structural performance, under concentrated loads, of roof and floor sheathing, separate from the effects of the framing, under simulated conditions representative of those in actual service.

5.2 The procedures are intended to be applied to roof or floor sheathing materials installed directly to framing. They are not intended for the evaluation of the framed assembly as a whole.

### 6. Apparatus

6.1 *Concentrated Load*—The apparatus for the concentrated load test shall conform to the following requirements (see Fig. 1):

6.1.1 *Supports*—The framing members shall be supported in order not to deflect under the applied loads. The support system shall include provisions for rigidly restraining the ends of the framing members, as with blocking and clamps, to prevent rotation or vertical movement during testing.

6.1.2 *Loading Device*—Any convenient means may be used for applying a compressive load up to ultimate, and for measuring the load within  $\pm 1\%$  accuracy. Load shall be applied through a ball-and-socket joint to assure even application.

6.1.3 *Loading Disks*—Two steel disks are required, one having a diameter of 25 mm (1 in.), representing a concentrated load, and one of 76 mm (3 in.) representing foot traffic, each with a thickness of at least 13 mm (0.50 in.). The edge of the loading disk contacting the test specimen shall be rounded to a radius not exceeding 1.5 mm (0.06 in.).

6.1.4 *Deflection Gage*, mounted on a rigid tripod whose legs rest on the sheathing immediately above the framing members that are adjacent to the load point (Fig. 1). The deflection gage should have a range exceeding the maximum anticipated deflection, have a maximum error of  $\pm 1\%$ , and be graduated to 0.02 mm (0.001 in.).

6.2 *Impact Load*—The apparatus for the impact load test shall conform to the requirements of 5.6.1.1-5.6.1.4. In addition, the following equipment shall be used:

6.2.1 *Drop Bag*—The bag shall be constructed as in 5.6.2.1.1-5.6.2.1.3 (see Fig. 2).

6.2.1.1 *Leather*—The leather used in construction of the bag shall be harness leather (oak tanned from packer hides); or latigo leather (alum and vegetable tanned), or both. It shall be selected from a back or a side to contain enough area of the required thickness. Leather thickness shall be expressed in ounces (1 oz = 0.4 mm ( $\frac{1}{64}$  in.)). The above terms are explained in Definitions Terminology D 1517.

6.2.1.2 *Thread*—Thread used to fabricate the bag shall be linen, of four or more plies, meeting the requirements for Type B, Class 1 or 2, of Fed. Spec. V-T-291E(1).

6.2.1.3 *Fabrication*—The bag shall be 710 mm (28 in.) high by 735 mm (29 in.) in circumference, with a sidewall of 8-oz leather 3 mm ( $\frac{1}{8}$  in.) thick. The vertical edges shall be sewn together flesh side out and the seam shall be reinforced with a piece of 8-oz leather overlapping 9 mm ( $\frac{3}{8}$  in.) on each side. The side shall then be turned hair side out and sewn to the bottom. The base (bottom disk) shall be 230 to 265 mm (9 to 10½ in.) in diameter of 12-oz leather 5 mm ( $\frac{3}{16}$  in.) thick. The seam attaching the sidewall to the base shall be 6 mm ( $\frac{1}{4}$  in.) from the edge of the base. Two rows of stitching shall be used for the vertical sidewall seam and the seam attaching the sidewall to the base.

<sup>3</sup> Available from Standardization Documents Order Desk, Bldg. 4 Section D, 700 Robbins Ave., Philadelphia, PA 19111-5094, Attn: NPODS.

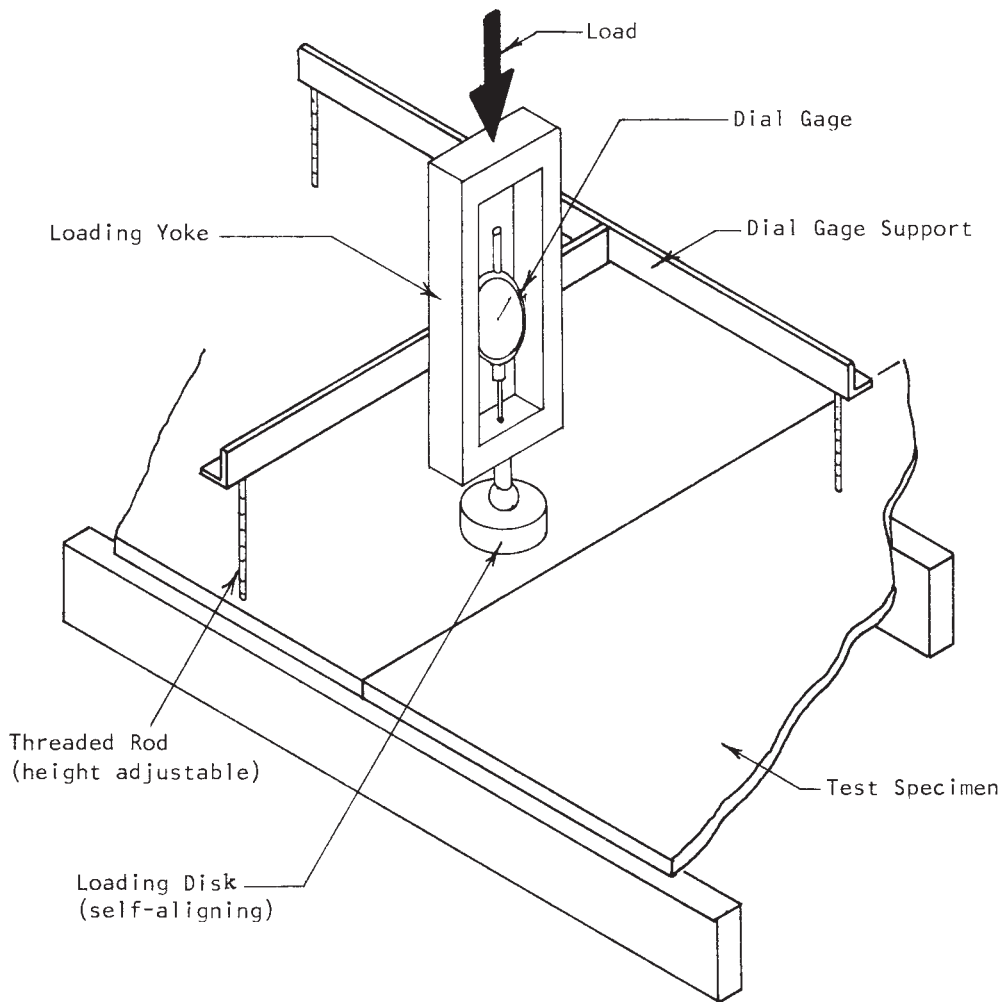

FIG. 1 Concentrated Static Load Apparatus

(a)(1) (a) The strap to hoist the bag shall be made from 8-oz leather 3 mm ( $\frac{1}{8}$  in.) thick by 16 mm ( $\frac{5}{8}$  in.) wide by 610 mm (24 in.) long. The strap shall be passed through holes, diametrically opposite, in the sidewalls 40 mm ( $1\frac{1}{2}$  in.) from the top of the wall. These holes shall be reinforced with pieces of 8-oz leather 76 mm (3 in.) square. The leather strap shall be passed twice through a 50-mm (2-in.) diameter lifting ring and the ends fastened by sewing, riveting, or by use of a buckle.

(b)(2) (b) To avoid excessive stretching of the leather sidewall or failure of the vertical seam, a sleeve, made from 12-oz leather, of the same type as the base of the bag, shall be fitted to slip tightly over the lower portion of the bag. This sleeve should be 250 mm ( $9\frac{7}{8}$  in.) high.

56.2.1.4 Shot—The bag shall be loosely filled with steel metal shot approximately 2.4 or pellets with diameters of 1 to 3.5 mm (0.094 in.) in diameter. (0.039 to 0.138 in.). Two layers of 76-mm (3-in.) thick foam rubber or similar padding shall be placed over the steel metal shot to prevent spillage during testing. Adjust the total weight of the drop bag and steel metal shot to the weight specified in Table 1,  $\pm\frac{1}{2}$  %. This value shall be verified before impact tests are conducted. For spans greater than 1220 mm (48 in.), the weight of the drop bag shall be as agreed upon between the interested parties.

56.2.2 Measuring Rod—A measuring rod, graduated in 152-mm (6-in.) increments and equipped with a sliding pointer, shall be used to measure the drop height of the bag.

## 67. Test Specimens

67.1 Select specimens that are representative of the product being evaluated, both in accordance with the inherent structural properties, including density, and in accordance with the thickness and thickness tolerances characteristic of the product. Unless otherwise specified, the number of tests shall be such as to develop the desired confidence level for each property measured, but conduct at least ten tests as a minimum for each test condition evaluated.

NOTE 2—A specimen can usually be made from a single panel, or assembled from a number of boards (see Figs. 3 and 4).

### 67.2 Specimen Size:

67.2.1 Length—The specimen length perpendicular to the main framing members shall conform to the center-to-center spacing,  $S$ , anticipated in service (Figs. 3 and 4). Where sheathing is continuous over more than one span, its length shall be equal to the

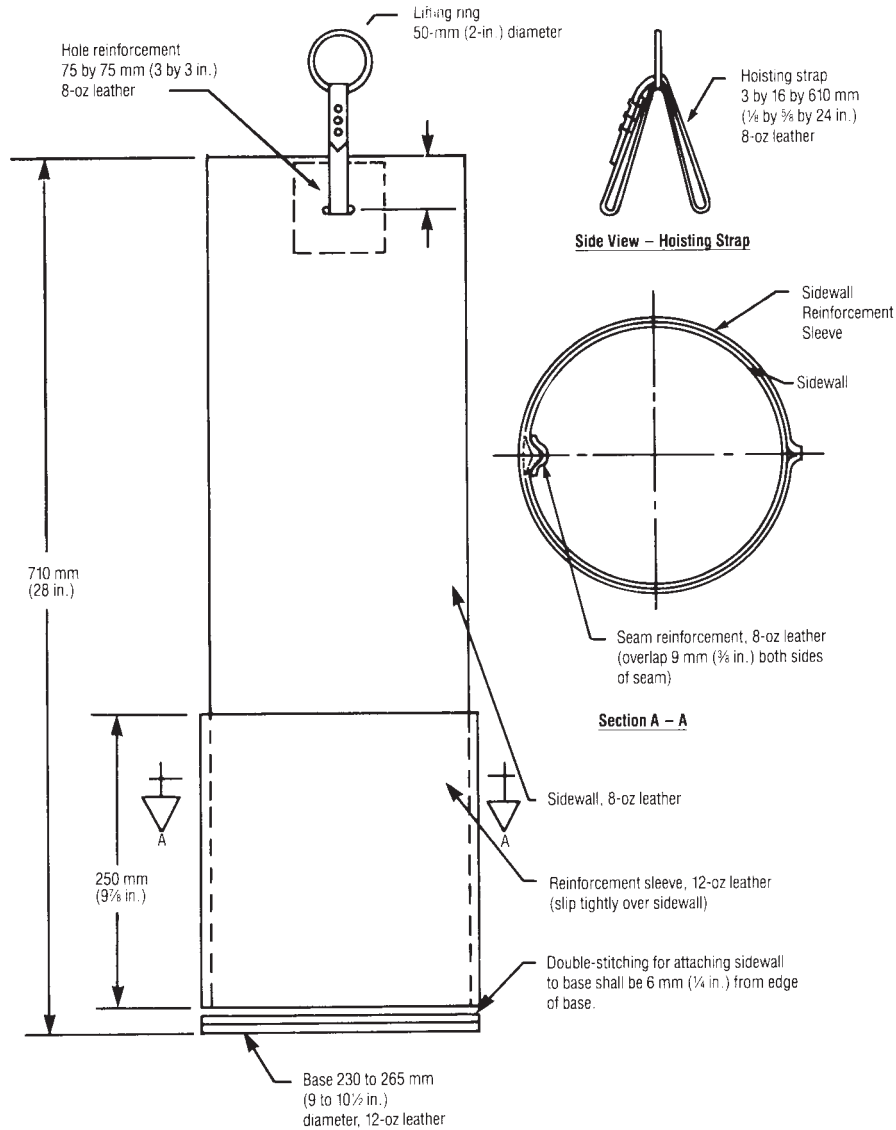

- (1) **Leather**—Use harness leather (oak-tanned from packer hides) or latigo leather (alum and vegetable tanned) (see Definitions D 1517 for definitions of terms) (1-oz leather = 1/64 in. (0.4 mm) thick).
- (2) **Thread**—Use linen thread (minimum four-ply) per Fed. Spec. V-T-291, Type B, Class 1 or 2. Double-stitch sidewall seam and seam attaching sidewall to base.
- (3) **Steel Shot**—Use steel shot (2.4-mm (0.095-in.) diameter). Fill bag with steel shot and cover with two layers of 76-mm (3-in.) foam rubber. Adjust total weight of assembly to 13.6 kg (30 lb) ± 1/2 %, or more, when specified (see 5.6.2.1.4).

FIG. 2 Leather Drop Bag Assembly

TABLE 1 Drop Bag Weights for Impact Load Tests

Sheathing Span, S	Total Weight of Drop Bag (Including Shot), kg (lb)
$S \leq 610$ mm (24 in.)	13.6 (30)
$610$ mm (24 in.) $< S \leq 1220$ mm (48 in.)	27.3 (60)
$S > 1220$ mm (48 in.)	<sup>A</sup>

<sup>A</sup> See 5.2.1.4.

minimum number of spans permitted or recommended for the product used and its intended application, multiplied by the center-to-center spacing of the framing members.

**67.2.2 Width**—The specimen width shall be at least 595 mm (23½ in.). The specimen width shall conform to its nominal width when edges are fully supported. When edges are unsupported or partially supported, sheathing may be trimmed to a width not less than 595 mm (23½ in.).

**67.2.3 Thickness**—Measure and report thickness of all sheathing specimens after conditioning in accordance with 6.7.3.1 and report.

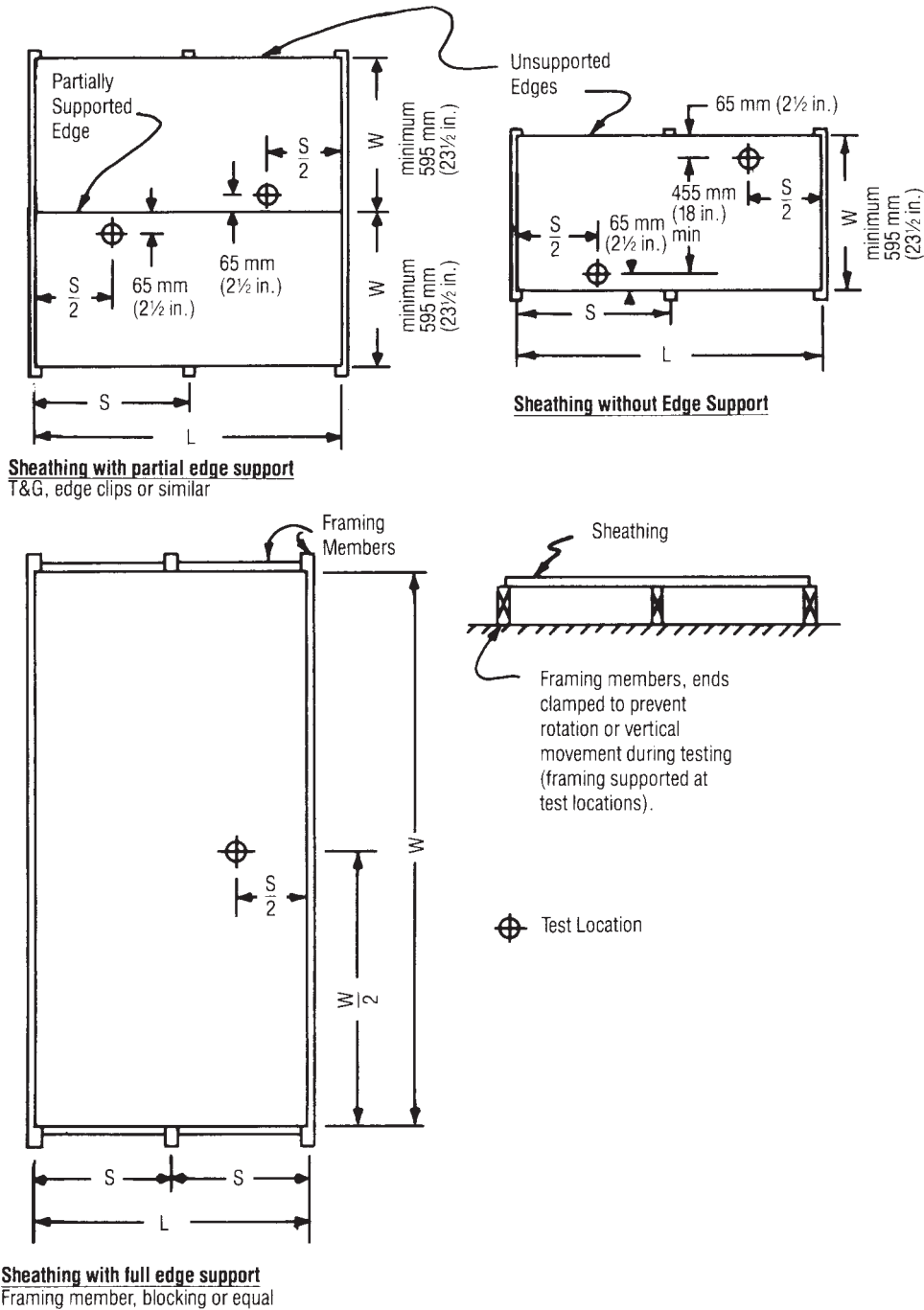

FIG. 3 Concentrated Static Load Test Specimens

67.2.4 Cut the sheathing to the required size prior to conditioning.

67.3 *Conditioning of Sheathing*—Prior to static and impact testing, subject sheathing to wetting and drying to simulate possible typical construction conditions. Test sheathing intended for roof applications under both dry and wet conditions, as described in 67.3.1 and 67.3.2. Test sheathing intended for subfloor or single-layer floor application both dry and in a re-dried condition after exposure to wet conditions, in accordance with 67.3.1 and 67.3.3. This sheathing may also be tested under wet conditions in accordance with 67.3.2 (see Note 1).

67.3.1 *Dry Tests*—Condition sheathing to either constant weight or moisture content or for at least 2 weeks, at  $20 \pm 3^\circ\text{C}$  ( $68 \pm 6^\circ\text{F}$ ) and  $65 \pm 5\%$  relative humidity.

67.3.2 *Wet Tests*—Expose sheathing to a continuous water spray for 3 days, applied to the top surface of the sheathing at a rate such as to keep this surface continuously wet. Position the sheathing so as to preclude water ponding on it, or immersion of any portion.

NOTE 3—A simplified spray tank may be used to support the sheathing in an approximately vertical position during exposure to the water spray. The

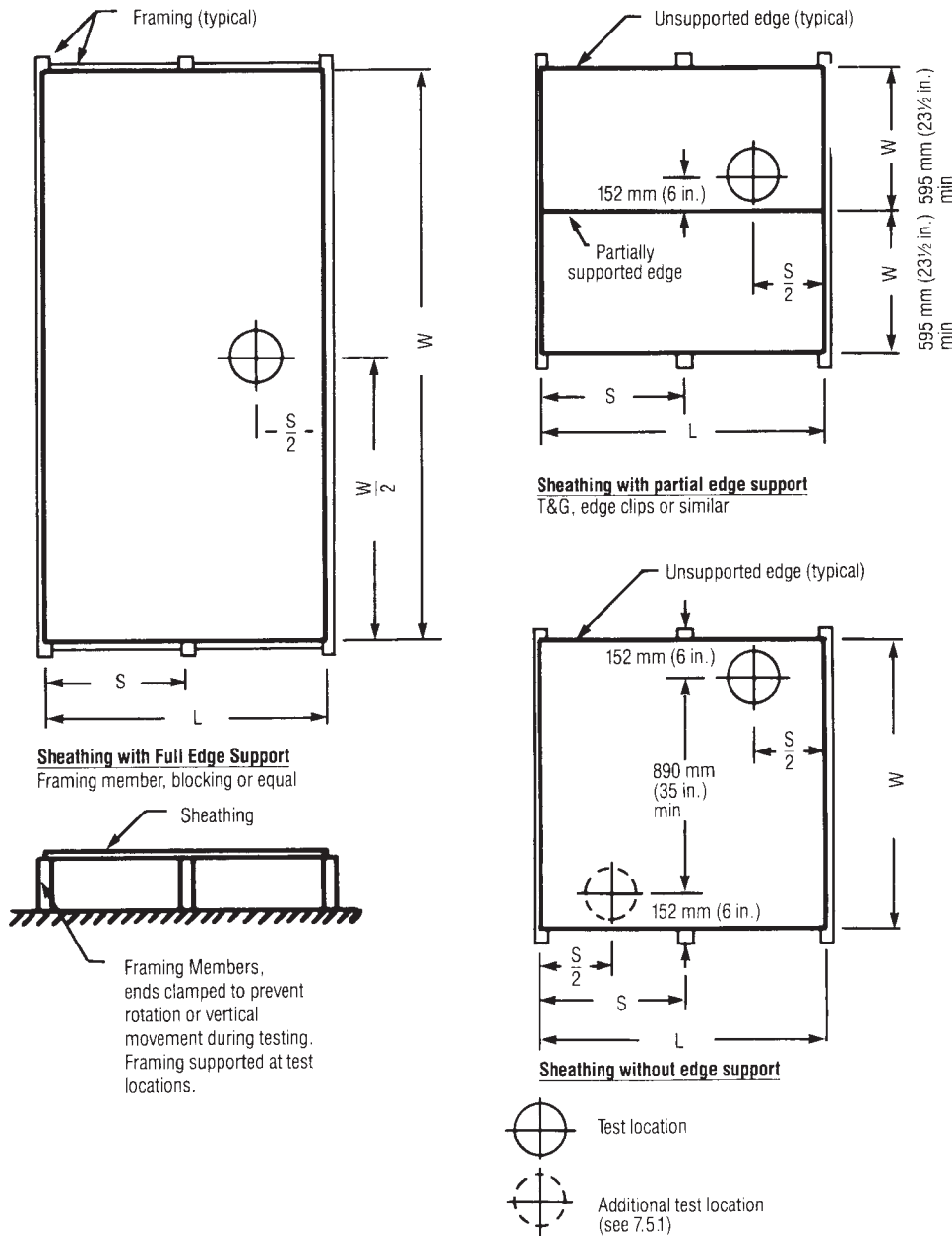

FIG. 4 Impact-Load Test Specimens

tank should be fitted with drains so that water spray does not accumulate, and the sheathing should be placed on blocks to elevate its lower edge above the residual water in the tank bottom.

**67.3.3 Re-dried Tests**—Expose sheathing to the 3-day water spray in accordance with 67.3.2 and then dry in accordance with 67.3.1.

**67.4 Fabrication of Test Specimens**—Install the conditioned sheathing on framing as shown in Figs. 3 and 4, using the type of framing, fastener schedule, and installation details as planned for use in service; consider this a part of the test conditions. After fabrication, test specimens promptly at ambient laboratory conditions.

NOTE 4—Where sheathing is installed on wood framing, the framing may be of any species and grade commonly used in construction that has a specific gravity of 0.40 to 0.55, oven-dry basis, with a maximum moisture content of 19 %. If nails are used, they may be double-headed to simplify disassembly of the specimen upon completion of testing, providing such nails will not damage the testing equipment. Framing may be reused for more than one test, provided it has not been significantly damaged by previous testing.

**78. Procedure**

**78.1 Concentrated Static Load Tests**—Apply the concentrated static load at one location on the top surface of the sheathing, midway between framing members (see Fig. 3).



78.1.1 If the edge of the sheathing is fully supported between main framing members, apply the concentrated load at midwidth. If the edge is unsupported, or partially supported, as with clips or a tongue and groove joint, apply the load 65 mm (2½ in.) in from the unsupported or partially supported edge as shown in Fig. 3.

78.1.2 Specimens may be used for more than one test provided the test locations are at least 455 mm (18 in.) apart (measured parallel to the framing), occur in different spans, and show no sign of damage from other tests.

78.2 *Stiffness*—Measure deflection relative to framing under the load point, using the 76-mm (3-in.) diameter loading disk.

78.2.1 Apply the load continuously to 890 N (200 lbf) to produce deflection at the rate of 2.5 mm (0.1 in.)/min and record the deflection-gage reading at 890 N (200 lbf). Remove the load.

78.3 *Strength of Roof and Subfloor Sheathing*—Determine the strength of roof sheathing in dry and wet conditions, and subfloor sheathing in dry and re-dried conditions (and wet if this condition is tested), using the 76-mm (3-in.) diameter loading disk (see Table 2).

78.3.1 Increase the load from zero so as to produce deflection at the rate of 5 mm (0.2 in.)/min, until the maximum load occurs and record the maximum load.

78.4 *Strength of Single-Layer Floor Sheathing*—Determine the strength of single-layer floor sheathing in dry and re-dried conditions using the 25-mm (1-in.) diameter disk (see Table 2).

NOTE 5—A single-layer floor is one that combines the structural functions of a subfloor with the smooth surface of an underlayment. Single-layer floor sheathing material is suitable for direct application to floor framing, and the direct installation of nonstructural finish floor covering.

78.4.1 Apply the load at a rate of 5 mm (0.2 in.)/min, until the maximum load occurs and record the maximum load.

78.4.2 If single-layer floor sheathing is tested wet (see 6.7.3), determine the strength using the 76-mm (3-in.) diameter disk. Apply the load from zero at a rate of 5 mm (0.2 in.)/min until the maximum load occurs and record the maximum load.

78.5 *Impact Load*— Apply the impact load at the most severe location, determined by preliminary testing of representative specimens (see Note 6). When the bag is dropped near an unsupported or partially supported edge, the impact point shall be 152 mm (6 in.) in from the edge. The weight of the drop bag shall be as specified in 5.6.2.1.4.

NOTE 6—The most severe location may be that which causes either maximum shear stresses or maximum flexural stresses. The former will normally occur near a rigid support. The latter will normally occur midway between framing members. If the sheathing edge is fully supported between main framing members, the critical flexural point will be at midwidth; if the edge is unsupported, or partially supported, as with clips or a tongue and groove joint, the critical flexural point will more likely be near the edge.

78.5.1 Specimens may be used for more than one test provided the test locations are at least 890 mm (35 in.) apart (measured parallel to the framing), occur in different spans (see Fig. 4), and show no sign of damage from other tests.

78.6 Prior to impact testing, measure the deflection of the sheathing relative to the framing members under 890-N (200-lbf) concentrated static load applied with the 76-mm (3-in.) diameter disk at the impact-load test location.

78.7 Remove the concentrated-load test apparatus, and apply the impact load, using the drop bag.

78.7.1 Drop the bag each time at the test location on the top surface of the sheathing, beginning with a drop height of 152 mm (6 in.) and increasing in 152-mm (6-in.) increments during the test. Measure the drop height from the bottom of the bag to the top surface of the sheathing over the adjacent framing members.

78.7.2 After each drop, apply a 890-N (200-lbf) concentrated load on the 76-mm (3-in.) diameter disk at the impact-load test location and measure the deflection.

78.7.3 Following the measurement of sheathing deflection under the 890-N (200-lbf) concentrated load, increase the concentrated load at the impact test location to produce deflection at a rate of 5 mm (0.2 in.)/min, until a specified proof load is reached. The concentrated load to be applied as the proof load shall be as agreed upon between the interested parties, with consideration of the intended use of the sheathing. Note whether the sheathing is capable of supporting the proof load (see 8.7.4.2), then remove the load.

78.7.4 Continue the impact test as in 7.8.7.1-7.8.7.3 using either Procedure A or B.

78.7.4.1 *Procedure A*— Until a specified drop height is reached.

78.7.4.2 *Procedure B*— Until the sheathing will no longer support the specified proof load. The drop height at which this occurs determines the ultimate impact load.

## 89. Recording of Data

89.1 For the concentrated static load, record the deflection-gage reading at 890 N (200 lbf). The deflection at the test location is the difference between the deflection-gage reading at 890 N (200 lbf) and the zero (no-load) reading.

**TABLE 2 Disk Diameters for Concentrated Load Strength**

Use Condition	Application		
	Roof <sub>1</sub> mm (in.)	Subfloor <sub>1</sub> mm (in.)	Single Floor <sub>1</sub> mm (in.)
Wet	76 (3)	76 (3) <sup>A</sup>	76 (3) <sup>A</sup>
Dry	76 (3)	76 (3)	25 (1)
Redried		<del>76 (3)</del>	<del>25 (1)</del>
Re-dried		76 (3)	25 (1)

<sup>A</sup> Optional test.



~~89.2~~ For the impact load, record the deflection-g measuring device reading under a 890-N (200-lbf) concentrated at zero load prior to starting (this is defined as the impact tests (initial reading) and after initial reading). another deflection reading is recorded at 890-N (200-lbf) load. Following each drop impact, a load of 890-N (200-lbf) is reapplied, and the bag. The cumulative deflection increment at the test location under this load is the difference between the deflection-gage reading recorded. The net deflection after each impact is the deflection reading recorded when a load application and of 890-N (200-lbf) is applied, less the initial reading.

~~89.3~~ Record the concentrated loads and bag-drop heights when the first significant break occurs that can be detected on the top or bottom, or both, surfaces of the sheathing (see Note 7). Record the proof load used and the maximum drop height at which the impact-load test was terminated (see ~~7~~ 8.7.4.1, Procedure A); or the bag-drop height at ultimate impact load (see ~~7~~ 8.7.4.2, Procedure B).

NOTE 7—A significant break of the sheathing is defined as a fracture that propagates into or through the sheathing or other deformation that affects its basic stiffness or strength. Minor “leafing” of the surface which may occur at the test location is not considered a significant break.

## **9. Report**

9.1 The report shall follow the general outline of Practice E 575, and shall specifically include the following information:

~~9.1.1~~ Dates of test and report.

~~9.1.2~~ Identification of the sheathing (manufacturer, source, dimensions, including thickness of each specimen, and other pertinent properties).

~~9.1.3~~ Detailed drawings that describe the assembly, including framing and fastening schedule, and other pertinent construction details.

~~9.1.4~~ Test technique including the conditioning used, arrangement of the test apparatus, loading-disk size, location of test points, the drop-bag weight, the proof load used, the drop height end point (if specified) for the impact load test, and any deviation from this test method.

~~9.1.5~~ Summarize the test data in ~~9.1.5.1-9.1.5.5~~ for all specimens included in the test series. Reporting of data noted in ~~9.1.5.6~~ and ~~9.1.5.7~~ is optional.

~~9.1.5.1~~ The minimum, maximum, and average deflection under a 890-N (200-lbf) concentrated load.

~~9.1.5.2~~ The minimum, maximum, and average ultimate concentrated load, as defined in ~~7.3.1~~ and ~~7.4.1~~.

~~9.1.5.3~~ The minimum, maximum, and average deflection under a 890-N (200-lbf) concentrated load, for each impact load increment (see ~~7.7.2~~).

~~9.1.5.4~~ The percentage of specimens tested that supported the specified proof load after the impact test reached the specified drop height end point, if Procedure A is used (see ~~7.7.4.1~~).

~~9.1.5.5~~ The minimum, maximum, and average bag-drop height at ultimate impact load, if Procedure B is used (see ~~7.7.4.2~~).

~~9.1.5.6~~ The minimum, maximum, and average concentrated static load at which the first significant break on the top or bottom, or both surfaces, of the sheathing is detected (see Note 7).

~~9.1.5.7~~ The minimum, maximum, and average impact drop height at which the first significant break on the top or bottom, or both surfaces, of the sheathing is detected (see Note 7).

## **10. Report**

10.1 The report shall follow the general outline of Practice E 575, and shall specifically include the following information:

10.1.1 Dates of test and report.

10.1.2 Identification of the sheathing (manufacturer, source, dimensions, including thickness of each specimen, and other pertinent properties).

10.1.3 Detailed drawings that describe the assembly, including framing and fastening schedule, and other pertinent construction details.

10.1.4 Test technique including the conditioning used, arrangement of the test apparatus, loading-disk size, location of test points, the drop-bag weight, the proof load used, the drop height end point (if specified) for the impact load test, and any deviation from this test method.

10.1.5 Summarize the test data in 10.1.5.1-10.1.5.5 for all specimens included in the test series. Reporting of data noted in 10.1.5.6 and 10.1.5.7 is optional.

10.1.5.1 The minimum, maximum, and average deflection under a 890-N (200-lbf) concentrated load.

10.1.5.2 The minimum, maximum, and average ultimate concentrated load, as defined in 8.3.1 and 8.4.1.

10.1.5.3 The minimum, maximum, and average deflection under a 890-N (200-lbf) concentrated load, for each impact load increment (see 8.7.2).

10.1.5.4 The percentage of specimens tested that supported the specified proof load after the impact test reached the specified drop height end point, if Procedure A is used (see 8.7.4.1).

10.1.5.5 The minimum, maximum, and average bag-drop height at ultimate impact load, if Procedure B is used (see 8.7.4.2).

10.1.5.6 The minimum, maximum, and average concentrated static load at which the first significant break on the top or bottom, or both surfaces, of the sheathing is detected (see Note 7).

10.1.5.7 The minimum, maximum, and average impact drop height at which the first significant break on the top or bottom, or both surfaces, of the sheathing is detected (see Note 7).

**11. Precision and Bias**

101.1 *Precision*—Neither the within-laboratory nor the between-laboratory precision of the concentrated load procedure and the impact load procedure has been established.

101.2 *Bias*—No reference standards are known to exist to measure the bias of this test method.

**112. Keywords**

112.1 concentrated static load; deflection resistance; drop-bag tests; floor sheathing; impact load; roof sheathing; ultimate impact load; wood sheathing

*ASTM International takes no position respecting the validity of any patent rights asserted in connection with any item mentioned in this standard. Users of this standard are expressly advised that determination of the validity of any such patent rights, and the risk of infringement of such rights, are entirely their own responsibility.*

*This standard is subject to revision at any time by the responsible technical committee and must be reviewed every five years and if not revised, either reapproved or withdrawn. Your comments are invited either for revision of this standard or for additional standards and should be addressed to ASTM International Headquarters. Your comments will receive careful consideration at a meeting of the responsible technical committee, which you may attend. If you feel that your comments have not received a fair hearing you should make your views known to the ASTM Committee on Standards, at the address shown below.*

*This standard is copyrighted by ASTM International, 100 Barr Harbor Drive, PO Box C700, West Conshohocken, PA 19428-2959, United States. Individual reprints (single or multiple copies) of this standard may be obtained by contacting ASTM at the above address or at 610-832-9585 (phone), 610-832-9555 (fax), or [service@astm.org](mailto:service@astm.org) (e-mail); or through the ASTM website ([www.astm.org](http://www.astm.org)).*