



Standard Test Method of Measuring Relative Resistance of Wall, Floor, and Roof Construction to Impact Loading¹

This standard is issued under the fixed designation E 695; the number immediately following the designation indicates the year of original adoption or, in the case of revision, the year of last revision. A number in parentheses indicates the year of last reapproval. A superscript epsilon (ϵ) indicates an editorial change since the last revision or reapproval.

1. Scope

1.1 This test method covers the measurement of the relative resistance of wall, floor, and roof construction to impact loading. The test is not applicable to doors.

1.2 The values stated in SI units are to be regarded as the standard.

1.3 *This standard does not purport to address all of the safety concerns, if any, associated with its use. It is the responsibility of the user of this standard to establish appropriate safety and health practices and determine the applicability of regulatory limitations prior to use.*

2. Referenced Documents

2.1 ASTM Standards:²

D 1517 Terminology Relating to Leather

E 73 Practice for Static Load Testing of Truss Assemblies

E 575 Practice for Reporting Data from Structural Tests of Building Constructions, Elements, Connections, and Assemblies

E 631 Terminology for Building Constructions

E 661 Test Method for Performance of Wood and Wood-Based Floor and Roof Sheathing Under Concentrated Static and Impact Loads

2.2 Other Standards:

Federal Specification V-T-291E (1) Thread, Linen³

3. Terminology

3.1 For definitions of terms related to this standard, see Terminology E 631.

4. Significance and Use

4.1 The procedures outlined will provide data that can be used to evaluate the relative performance of wall, floor, and

roof constructions under conditions representative of those sustained in actual service when subjected to impact by a heavy blunt object. See Test Method E 661 for evaluation of floor and roof sheathing and Practice E 73 for evaluation of roof trusses.

4.2 The method is intended to be applied to relatively light construction, including, but not limited to, wood floor and roof systems, partitions framed with wood or steel studs, steel floor or roof decking systems, steel siding and wall panels, or thin concrete and masonry walls or slabs and similar assemblies.

5. Summary of Method

5.1 Specimens of wall, floor, and roof construction are subjected to the impact force of a standard impact instrument. Wall sections are tested in the vertical position. Floor and roof sections are tested only in the horizontal position. Because of the inherent differences in the method of applying load, measurements obtained from tests in a horizontal mode are not comparable to measurements obtained from tests in the vertical mode.

6. Apparatus for Floor and Roof Systems, Specimen Horizontal (see Fig. 1)

6.1 *Supports*, steel rollers, two, on a rigid base.

6.2 *Impact Instrument*, made with a shot-filled leather bag as specified in 6.2.1-6.2.6. (see Fig. 2.)

6.2.1 *Leather*—The leather used in construction of the bag should be harness leather (Note 1), oak tanned (Note 1) from packer hides (Note 1) or latigo leather (Note 1), alum and vegetable tanned, or both. Leather thickness shall be expressed in ounces (Note 1) (1 oz = 0.4 mm (1/64 in.)).

NOTE 1—See Terminology 1517.

6.2.2 *Thread*—Thread used in fabrication of the bag shall be linen thread of four or more plies, meeting the requirements for Type B, Class 1 or 2, of Federal Specification V-T-291E (1).

6.2.3 *Fabrication*—The side of the bag shall be 710 mm (28 in.) high by 735 mm (29 in.) in circumference, with a sidewall of 8-oz leather 3 mm (1/8 in.) thick. The vertical edges shall be sewed together flesh side out and the seam shall be reinforced with a piece of 8-oz leather overlapping 10 mm (3/8 in.) each side. The side shall then be turned hair side out and sewed to the bottom. The base (bottom disk) shall be 230 mm (9 in.) in diameter of 12-oz leather 5 mm (3/16 in.) thick. The seam

¹ This method is under the jurisdiction of ASTM Committee E06 on Performance of Buildings and is the direct responsibility of Subcommittee E06.11 on Horizontal and Vertical Structures/Structural Performance of Completed Structures.

Current edition approved Oct. 1, 2003. Published November 2003. Originally approved in 1979. Last previous edition approved in 1997 as E 695 – 79 (1997) ^{ϵ 1}.

² For referenced ASTM standards, visit the ASTM website, www.astm.org, or contact ASTM Customer Service at service@astm.org. For Annual Book of ASTM Standards volume information, refer to the standard's Document Summary page on the ASTM website.

³ Available from Standardization Documents Order Desk, Bldg. 4 Section D, 700 Robbins Ave., Philadelphia, PA 19111-5094, Attn: NPODS.

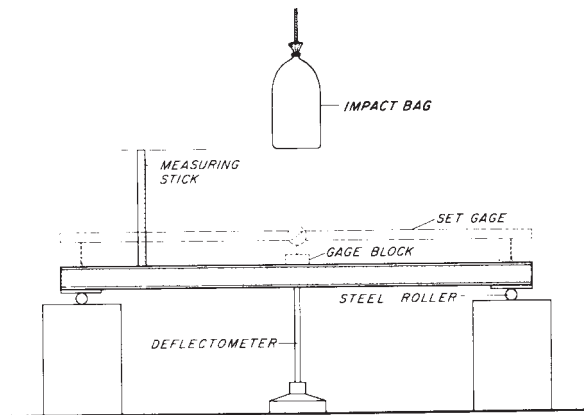

FIG. 1 Impact Load Test (Specimen Horizontal)

attaching the wall to the base shall be 6 mm ($\frac{1}{4}$ in.) from the edge of the base. Two rows of stitching shall be used for the vertical wall seam and the seam attaching the wall to the base.

6.2.4 Hoisting Strap—The strap to hoist the bag shall be made from 8-oz leather 3 mm ($\frac{1}{8}$ in.) thick by 16 mm ($\frac{5}{8}$ in.) wide by 610 mm (24 in.) long. The strap shall be passed through holes, diametrically opposite, in the side walls 40 mm ($1\frac{1}{2}$ in.) from the top of the wall. These holes shall be reinforced with pieces of 8-oz leather and 76 mm (3 in.) square. The leather strap shall be passed twice through a 50-mm (2-in.) diameter lifting ring and the ends fastened by sewing, riveting, or by use of a buckle. To avoid excessive stretching of the leather wall or failure of the vertical seam, a sleeve, made from 12-oz leather, of the same type as the base of the bag, shall be fitted to slip tightly around the lower portion of the bag. This sleeve should be 250 mm ($9\frac{7}{8}$ in.) high.

6.2.5 Shot—The bag shall be loosely filled with metal shot or pellets with diameters of 1 to 3.5 mm (0.039 to 0.138 in.). Two layers of 75-mm (3-in.) thick foam rubber or similar padding shall be placed over the lead shot to prevent spillage during testing.

6.2.6 The total mass of the bag, including shot, shall be adjusted to the desired level with an accuracy of $\pm 1\%$. The mass of the bag may be adjusted to any specified mass, depending upon the information desired.

6.3 Measuring Sticks—A stick, laid off in 150-mm (6-in.) increments, or a series of sticks the lengths of which are multiples of 152 mm (6 in.), to measure the height of drop accurately. A graduated sliding pointer, a standard metal tape measure, or any similar device that can accurately measure the height of drop may be substituted.

6.4 Deflectometer, or other suitable deflectometer equipment, consisting of a metal tube having a base at the lower end and a clamp at the upper end which supports, by friction, a light metal rod. The rod shall be movable inside the tube and shall be graduated to 0.25-mm (0.01-in.) divisions.

6.5 Set Gage, consisting of a light, rigid frame having two legs at one end and one leg at the other end, with the distance between the legs equal to the span of the specimen. A dial micrometer graduated to 0.025-mm (0.001-in.) divisions shall be attached to the frame at midlength.

6.6 Gage Blocks, 300 by 300 mm (12 by 12 in.) in area, and constructed of metal or other hard surface material.

6.7 Hold-Downs—Clamps or other restraining devices at the specimen ends to minimize translation.

7. Apparatus for Wall Systems, Specimen Vertical (see Fig. 3)

7.1 Steel Channels, for support of the specimen at top and bottom.

7.2 Rollers, cylindrical rollers and two supporting rollers.

7.3 Impact bag, measuring sticks, deflectometer, set gage, and gage blocks conforming to the requirements specified in 6.2-6.7.

7.4 Rigid Supporting Frame, to which the supporting channels and deflection gage are attached.

8. Test Specimen

8.1 Size—The specimens shall be representative of the actual construction as to material, method of assembly, and workmanship.

8.2 Length or Height—The length or height of specimen for each element shall be chosen to conform approximately to the length or height of that element in actual size.

8.3 Width—The width of specimen shall be chosen, insofar as feasible, to include several of the principal load-carrying members to ensure that the behavior under load will simulate that anticipated under service conditions. The actual width of specimens shall be a whole number multiplied by the spacing of the principal load-carrying members, except for prefabricated panels for which the actual width shall be the width of panel used. If the structural properties of a particular construction are to be compared with another construction, there should not be a great difference in the actual widths of the specimens.

8.4 Age—Constructions such as concrete and masonry (brick, structural clay tile, concrete block) for which the structural properties depend upon the age of the specimen, shall be tested not less than 25 days nor more than 56 days after fabrication except in special instances such as the case of existing panels. This age requirement applies also to plastered and stuccoed constructions. Other assemblies affected by moisture shall be conditioned to constant weight or moisture content, or for at least 2 weeks at $20 \pm 3^\circ\text{C}$ ($68 \pm 6^\circ\text{F}$) and $65 \pm 5\%$ relative humidity.

8.5 Number—Tests shall be made on a minimum of three like specimens. However, more tests may be necessary depending upon information and accuracy desired.

9. Procedure

9.1 For symmetrical walls, apply the impact load to the outside face from at least one of the specimens, and to the inside face of the other two specimens. For asymmetrical walls, test both sides an equal number of times. This will require a minimum of four test specimens. Exception: only one side need be tested at the option of the client and laboratory depending upon information required. The report shall record which side or sides of the specimen that is tested. For floor and roof assemblies apply the impact loads only to the upper finish-floor face of the specimen.

NOTE 2—Any criteria for pass/fail or for stopping the test should be agreed upon between the sponsor and testing agency prior to testing. Some

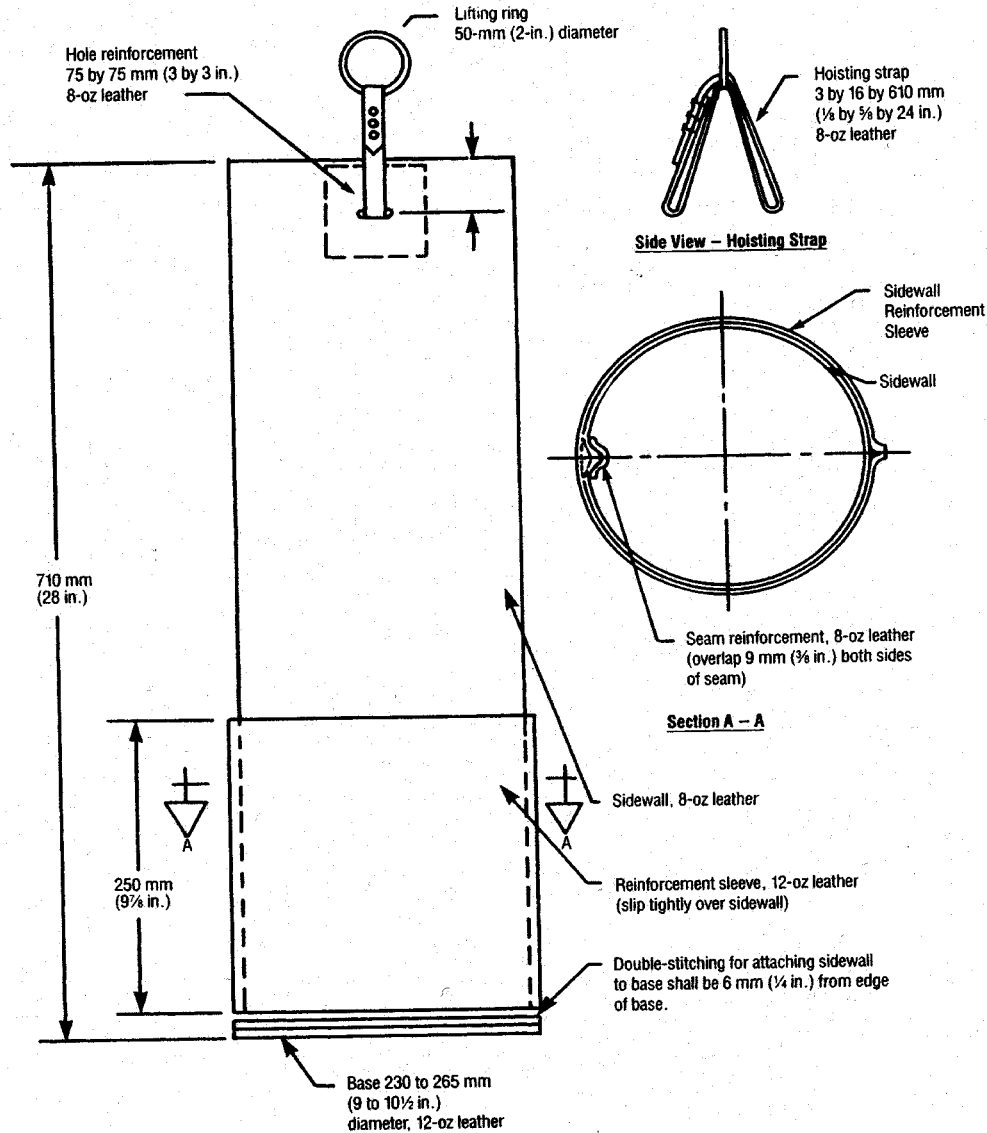

(1) *Leather*—Use harness leather (oak tanned from packer hides) or latigo leather (alum and vegetable tanned) (see Terminology D 1517 for definitions and terms) (1-oz leather = 1/64 in. (0.4 mm) thick).

(2) *Thread*—Use linen thread (minimum four-ply) per Fed. Spec. V-T-291, Type B, Class 1 or 2. Double-stitch sidewall seam and seam attaching sidewall to the base.

(3) *Shot*—Use shot (1 to 3.5 mm (0.039 to 0.138 in.) diameter). Fill bag with shot and cover with two layers of 76 mm (3 in.) foam rubber.

FIG. 2 Leather Drop Bag Assembly

possible points include: the ability to sustain a specified static load after the impact drop; limitation on the instantaneous deflection or residual set; penetration of panel; destruction of panel (to be defined); or simply a specified height of drop or number of drops per test from a specific height.

9.2 *Point of Impact*—If the construction has structural members, that is, studs or joists, test each specimen so that at least one such structural member will be struck by the impact bag. Test each specimen also so that the impact bag will strike the facing midway between two members.

NOTE 3—As written, this method may not necessarily define or test the most vulnerable part of a panel specimen. Additional tests may be required to locate such an area if this information is desired.

9.3 *Loading-Floor and Roof Assemblies-Specimen Horizontal*—Test the specimen as a simple beam on a span

nominally 150 mm (6 in.) less than the specimen length. The two supports for the specimens shall prevent longitudinal restraint and shall provide bearing for the entire width of the specimen. Secure the ends of the panel by hold-downs to minimize specimen bounce. Take care to assure that the hold-downs do not affect deflection of the specimen. Apply an impact load to the upper face of the specimen by dropping the bag beginning with a height of 152 ± 6 mm (6 ± 1/4 in.) and increasing the height in 152 ± 6-mm (6 ± 1/4-in.) increments. Record set and instantaneous deflection measurements for each drop. For the first drop, measure the height of the bag from the upper face of the specimen at a point directly beneath the bag, and for subsequent drops, from a taut cord in contact with the upper face directly above the supports.

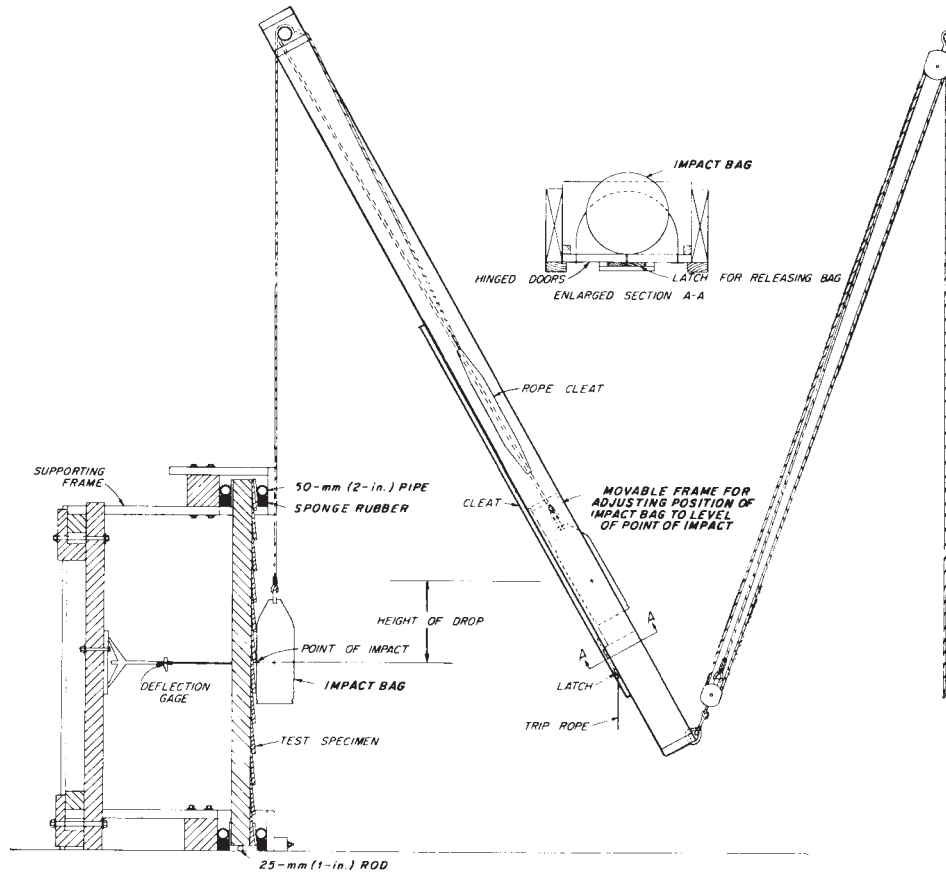

FIG. 3 Impact Load Test (Specimen Vertical)

9.4 *Loading-Wall Assemblies Specimen Vertical*—Position the specimen on cylindrical rollers to prevent transverse restraint. The axes of the rollers shall be parallel to the faces of the specimens. The two supporting rollers shall be in contact with the vertical surface of the rigid frame and each roller shall rest horizontally on sponge rubber 16 ± 3 mm ($5/8 \pm 1/8$ in.) thick to prevent longitudinal restraint. Support the bag as a pendulum in the frame as shown in Fig. 3. Take care to assure that the hold-downs do not affect deflection of the specimen. Apply an impact load to the middle of the outer face of the specimens by releasing the bag beginning with a height of 152 ± 6 mm ($6 \pm 1/4$ in.) and increasing the height in 152 ± 6 mm ($6 \pm 1/4$ -in.) increments. The maximum useful height of drop will occur when the pendulum or frame is perpendicular to the specimen. Measure the height of drop from the point of impact of the center of gravity of the bag as it strikes the specimen to this same point when the bag is in the raised position. Release the bag by smoothly and swiftly opening the hinged doors, causing it to swing as a true pendulum thus eliminating wobbling.

9.5 *Instantaneous Deflection*—Use the deflectometer (see 6.4) to measure the instantaneous deflection of the specimen. Prior to loading, hold the light metal rod in contact with the middle of the lower face of the specimen by the clamp. When the specimen deflects under the impact load, the rod is held in its lowest position by the friction clamp. Report readings to the nearest 0.25 mm (0.01 in.).

9.6 *Set*—To measure the set, place the set gage on the upper face of the specimen. Take readings by placing the set gage on the specimen with the legs at the supports and the spindle of the dial micrometer in contact with the middle of the specimen, and reading the micrometer. If the set exceeds the range of the micrometer, place gage blocks between the specimen and the spindle of the micrometer to the nearest 0.025 mm (0.001 in.).

10. Recordings

10.1 *Deflection and Set*—For each height of drop calculate the deflection between the reading of the deflectometer and the initial reading. Similarly, calculate the set as the difference between the reading of the set gage and the initial reading. Record the maximum height of drop.

11. Report

11.1 The report shall follow the format of Practice E 575. In addition, the report shall also include the following:

11.2 Description of test assembly, including:

11.2.1 Size of test specimen,

11.2.2 Details of structural design, including where applicable or required, the design stresses, design loads, and safety factors of all structural members in test assembly,

11.2.3 Plan, elevation, principal cross section, plus other sections as needed for clarity, and

11.2.4 Details of attachment of test panel in frame.

11.3 Summarize results.

11.4 It is essential that drawings required by 3.1.6 of Practice E 575 be provided.

12. Precision and Bias

12.1 Neither the within-laboratory nor the between-laboratory precision and bias of the impact load procedures recommended have been established, because any test data developed are usually of a proprietary nature and unavailable.

Furthermore, the test method is expected to be used for prototype testing and not for routine quality control. This means few specimens of a kind would be tested, making any analysis unjustifiable.

13. Keywords

13.1 floor systems; impact loading; roof systems; wall systems

ASTM International takes no position respecting the validity of any patent rights asserted in connection with any item mentioned in this standard. Users of this standard are expressly advised that determination of the validity of any such patent rights, and the risk of infringement of such rights, are entirely their own responsibility.

This standard is subject to revision at any time by the responsible technical committee and must be reviewed every five years and if not revised, either reapproved or withdrawn. Your comments are invited either for revision of this standard or for additional standards and should be addressed to ASTM International Headquarters. Your comments will receive careful consideration at a meeting of the responsible technical committee, which you may attend. If you feel that your comments have not received a fair hearing you should make your views known to the ASTM Committee on Standards, at the address shown below.

This standard is copyrighted by ASTM International, 100 Barr Harbor Drive, PO Box C700, West Conshohocken, PA 19428-2959, United States. Individual reprints (single or multiple copies) of this standard may be obtained by contacting ASTM at the above address or at 610-832-9585 (phone), 610-832-9555 (fax), or service@astm.org (e-mail); or through the ASTM website (www.astm.org).