



Standard Test Methods of Conducting Strength Tests of Panels for Building Construction¹

This standard is issued under the fixed designation E 72; the number immediately following the designation indicates the year of original adoption or, in the case of revision, the year of last revision. A number in parentheses indicates the year of last reapproval. A superscript epsilon (ε) indicates an editorial change since the last revision or reapproval.

This standard has been approved for use by agencies of the Department of Defense.

INTRODUCTION

Sound engineering design of structures, using existing or new materials requires accurate technical data on the strength and rigidity of the basic elements employed in various construction systems. It is the purpose of these test methods to provide a systematic basis for obtaining engineering data on various construction elements and structural details of value to designers, builders, building officials, and others interested in this field. The results should closely approximate the performance in actual service.

1. Scope

1.1 These test methods cover the following procedures for determining the structural properties of segments of wall, floor, and roof constructions:

Test Specimens	Section	3
Loading		4
Deformation Measurements		5
Reports		6
Precision and Accuracy		7
TESTING WALLS		
Significance and Use		8
Compressive Load		9
Tensile Load		10
Transverse Load—Specimen Horizontal		11
Transverse Load—Specimen Vertical		12
Concentrated Load		13
Impact Load—See Test Methods E 695 and E 661		
Racking Load—Evaluation of Sheathing Materials on a Standard Wood Frame		14
Racking Load—Evaluation of Sheathing Materials (Wet) on a Standard Wood Frame		15
TESTING FLOORS		
Significance and Use		16
Transverse Load		17
Concentrated Load		18
Impact Load—See Test Methods E 695 and E 661		
TESTING ROOFS		
Significance and Use	Section	19

Transverse Load	20
Concentrated Load	21
APPENDIX	
Technical Interpretation	Appendix X1

1.2 Metric units are to be considered as the primary standard units.

2. Referenced Documents

2.1 ASTM Standards:

- E 4 Practices for Force Verification of Testing Machines²
- E 73 Practice for Static Load Testing of Truss Assemblies³
- E 564 Practice for Static Load Test for Shear Resistance of Framed Walls for Buildings³
- E 575 Practice for Reporting Data from Structural Tests of Building Constructions, Elements, Connections, and Assemblies³
- E 661 Test Method for Performance of Wood and Wood-Based Floor and Roof Sheathing Under Concentrated Static and Impact Loads³
- E 695 Test Method of Measuring Relative Resistance of Wall, Floor, and Roof Constructions to Impact Loading³

3. Test Specimens

3.1 *Size*—There shall be at least three specimens for each test. *Specimens shall be constructed to represent sections of the wall, floor, or roof assembly.* The specimens shall be representative as to material and workmanship and shall be of the largest *practical size to predict structural performance attributes of the assembly.* Unsymmetrical assemblies shall be tested in each axis for which the results may be different.

¹ These test methods are under the jurisdiction of ASTM Committee E06 on Performance of Buildings and are the direct responsibility of Subcommittee E 06.11 on Horizontal and Vertical Structures/Structural Performance of Completed Structures.

Current edition approved Oct. 10, 2002. Published November 2002. Originally published as E 72 – 47 T. Last previous edition E 72 – 98.

² *Annual Book of ASTM Standards*, Vol 03.01.

³ *Annual Book of ASTM Standards*, Vol 04.11.

3.2 *Length or Height*—The length or height of specimen for each element shall be chosen to conform to the length or height of that element in actual use.

3.3 *Width*—The width of specimen shall be chosen, insofar as possible, to include several of the principal load-carrying members to ensure that the behavior under load will simulate that under service conditions. With the exception of specimens for the racking load test, the nominal width of wall specimens shall be 1.2 m (4 ft). The actual width of specimens shall be a whole number multiplied by the spacing of the principal load-carrying members except for prefabricated panels, for which the actual width shall be the width of panel used. If the structural properties of a particular construction are to be compared with another construction, there should not be a great difference in the actual widths of the specimens.

3.4 *Age*—Constructions, such as concrete and masonry (brick, structural clay tile, concrete block) for which the structural properties depend upon the age of the specimen, shall be tested not less than 25 days nor more than 31 days after fabrication. This age requirement applies also to plastered and stuccoed constructions.

4. Loading

4.1 *Apparatus*—The testing machine or load-measuring apparatus shall comply with the requirements prescribed in Methods E 4.

4.2 *Application of Load*—Apply the load to all of the specimens in any test in increments so chosen that a sufficient number of readings will be obtained to determine definitely the load-deformation curve (see Section 6). Record the initial reading of the load and the reading of the deformation, either with no load on the specimen or under a small initial load. Increase the load to the first increment and record the deformation. Unless otherwise specified, decrease the load to the initial load and record the set (sometimes designated “permanent set”). Increase the load to two increments and record the set, when it is released to the initial load. Follow this sequence of readings for three increments, four increments, etc., of load. When for each specimen the behavior of the specimen under load indicates that the specimen might fail suddenly and damage the deformation-measuring apparatus, remove this apparatus from the specimen and increase the load continuously until the maximum load that can be applied to the specimen is determined.

4.3 *Duration of Load Application*—Except for racking tests, after each increment of load is applied, maintain the load level as constant as possible for a period of 5 min (see Note 1). Take deformation readings as soon as practical after load application, at the end of the 5-min period under constant load, and immediately and at the end of the 5-min period after any partial or complete load release. Plot initial and 5-min readings in the form of load-deformation curves. Maintain complete load-deformation-time records throughout the test. If application of a given load is required for a certain period, such as 24 h, take deformation readings at the beginning, at intervals during this period, and at the end of this period, to allow the satisfactory plotting of a time-deformation curve for the complete period.

NOTE 1—Reasons for the 5-min application of constant-level increment loads are as follows:

- (1) To permit the assembly to come to a substantial rest prior to taking the second set of readings (Depending on the method employed for applying the test load, it may be necessary to continue, at a reduced rate, the motion of the loading device in order to maintain the constant load level during the 5-min period.)
- (2) To provide sufficient time for making all observations. (Longer time intervals may be required under certain conditions.)
- (3) To observe any time-dependent deformation or load redistribution, or both, and to record accurately the load level when time-dependent deformation starts, that is, at the divergence of the immediate and delayed load-deformation curves. This load level may, under certain conditions, have an important bearing on the design load.
- (4) To be able to stop the test, if this should be desirable, prior to total failure, after initial failure has been anticipated as a result of the observations.
- (5) To assure uniformity in test performance and consistency in test results.

5. Deformation Measurements

5.1 Measure the deformations with sufficient precision to define the load-deformation relationship, and report at least to the nearest 0.25 mm (0.01 in.). The deformation-measuring apparatus specified for any loading may be replaced by other apparatus, provided that it permits readings of deformation that are equivalent in accuracy to those from the specified apparatus.

6. Reports

6.1 Show the results of each of the tests graphically, as illustrated in Fig. 1. Plot loads as ordinates and the deformations as abscissas for all tests. There shall be at least three specimens for each test, and the results for each test shall be shown on the same graph. Show the points for deformation under load by open circles and those for set by solid circles. Average the three values for either the deformation or the set and plot this average value in pencil on the graph. Draw a smooth curve among the average points to show the average behavior of the construction. The load-deformation curves shall be continuous lines and the load-set curves shall be

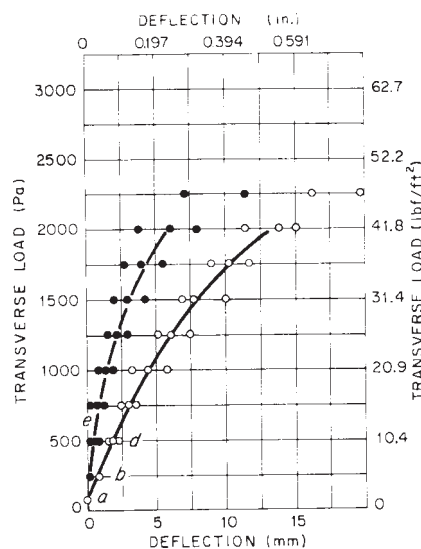

FIG. 1 Typical Graph Showing Results

dashed lines. Although the particular specimen for each point on the graph is not designated, record it on the laboratory data sheets. If readings are obtained under greater loads for some specimens than for others, plot all the values, but draw the curves only to the average values for which there are three values.

6.2 Prepare the test report in accordance with Recommended Practice E 575.

7. Precision and Bias

7.1 No statement is made either on the precision or on the bias of these test methods due to the variety of materials and combinations of materials involved.

TESTING WALLS

8. Significance and Use

8.1 The procedures described are those that will test the behavior of segments of wall construction under conditions representative of those encountered in service. Performance criteria based on data from those procedures can ensure structural adequacy and service life.

9. Compressive Load

9.1 *Test Specimens*—Tests shall be made on three like specimens, each having a height equal to the length of the element and a nominal width of 1.2 m (4 ft) (see Section 3).

9.2 *Apparatus*—The apparatus shall be assembled as shown in Fig. 2 and shall conform to the detailed requirements for component parts prescribed in 9.2.1 and 9.2.2, or the equivalent.

9.2.1 *Compressometer*—A bracket shall be attached to the specimen near the upper end, supporting a metal rod. A bracket shall also be attached to the specimen near its lower end, supporting a deflection—measuring device with the spindle up

and the gage length shall be recorded. The conical end of the rod shall seat in a hole in the end of the spindle and the rod and spindle shall be held in contact by stretched rubber bands. The deflection—measuring device shall be graduated to 0.025 mm (0.001 in.) or less.

9.2.2 *Deflectometer*—A fine wire shall be attached to a clamp near the upper end of the specimen. The free end connected to stretched rubber bands shall be attached to a clamp near the lower end of the specimen. A mirror having a paper scale one-half the width of the mirror shall be attached horizontally to the edge of the specimen at midheight. The scale shall be graduated to 2.5 mm (0.1 in.) or less.

9.3 Procedure:

9.3.1 *Loading*—Test the specimen as a column having a flat end at the bottom (Fig. 2). Apply compressive loads to a steel plate covering the upper end of the specimen. Apply the load uniformly along a line parallel to the inside face, and one-third the thickness of the specimen from the inside face. For wood construction, a rate of loading corresponding to a movement of the testing machine crosshead of nominally 0.8 mm/min (0.03 in./min) has been found satisfactory.

9.3.2 *Load-Deformation Data*—Attach four compressometers to the faces of the specimen, one near each corner of the specimen as shown in Fig. 2, to measure the shortening of the specimen. Record the readings to the nearest 0.025 mm (0.001 in.).

9.3.3 *Lateral Deflection*—Attach two deflectometers, one to each edge of the specimen, as shown in Fig. 2. Record the readings, when the image of the wire coincides with the wire, to the nearest 0.25 mm (0.01 in.).

9.4 Calculations and Report:

9.4.1 *Deformation*—For each compressometer, calculate the shortening under each load as the difference between the reading of the compressometer when the load is applied and the

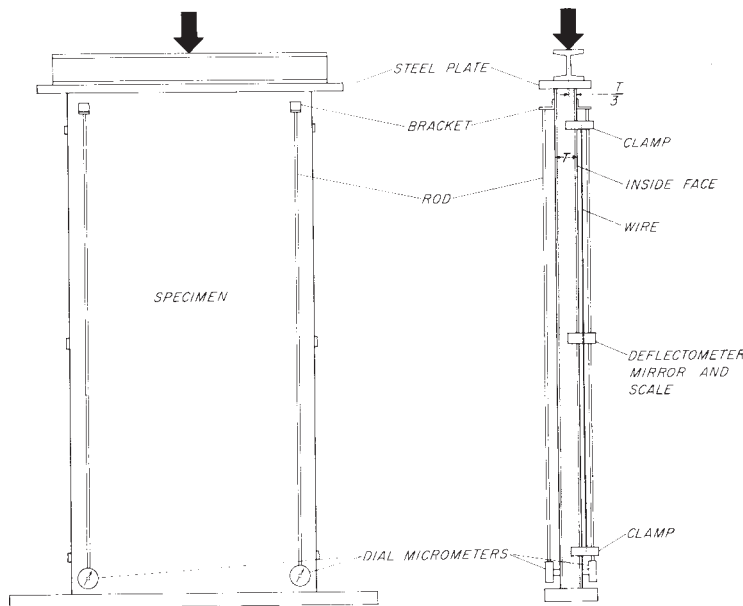

FIG. 2 Compressive Load Test on Wall Specimen

initial reading. Calculate the shortening of the specimen as the average of the shortenings for each of the four compressometers multiplied by the ratio: specimen length divided by the compressometer gage length. Obtain the sets in a similar manner.

9.4.2 *Lateral Deflection*—Calculate the lateral deflection and the lateral set under each load for each deflectometer as the difference between the reading of the deflectometer when the load is applied and the initial reading. Calculate the lateral deflection and lateral set for the specimen as the average of the lateral deflection and lateral set of the two deflectometers.

9.4.3 *Data Presentation*—Record the maximum load for each specimen and report the results of load-deformation and load-deflection measurements in the form of a graph in accordance with Section 6. Report gage lengths of all deflection or deformation gages.

10. Tensile Load

10.1 *Test Specimens*—Tests shall be made on three like specimens, each having a height equal to the length of the element and a nominal width of 1.2 m (4 ft) (see Section 3).

10.2 *Apparatus*—The apparatus preferably shall be assembled in a vertical testing machine and shall conform to the detailed requirements for component parts prescribed in 9.2.1 and 9.2.2, or the equivalent, with the exception that the compressometers prescribed in 9.2.1 shall be replaced by extensometers which shall be like the compressometers but so adjusted before load is applied that the stretch of the specimen can be measured.

10.3 Procedure:

10.3.1 *Loading*—Test the specimen as a tension specimen by uniform application of tensile forces along the line of the fastenings at the top and the bottom of the wall in a building. The top and bottom pulling fixtures may be attached to the specimen by fastenings similar to those used in a building, provided that, under the maximum load, failure of the specimen occurs between the top and the bottom of the specimen, not in either the pulling fixtures or the fastenings. If, under the tensile load, failure occurs either in a pulling fixture or in a fastening, the results of the test determine only the properties of the fixtures or the fastenings, not of the wall construction. When the failure occurs in fastenings, the tensile load indicates the maximum tensile strength of the construction that can be realized in actual service unless improved fastenings are provided.

10.3.1.1 *Masonry Constructions*—The construction may be continued upward beyond the top of the specimen and downward below the bottom of the specimen to enclose attachments for the pulling fixtures.

10.3.1.2 *Framed Wall Constructions*—If the construction has studs (either of wood or metal) the studs may be extended upward and downward beyond the top and bottom of the specimen and attached to the pulling fixtures. If the framed wall has plates at the top and the bottom, attach the pulling fixtures to the plates in the specimen.

10.3.2 *Load-Deformation Data*—Attach four extensometers to the faces of the specimen, one near each corner, as shown in Fig. 2, to measure the stretch of the specimen. Record the readings to the nearest 0.025 mm (0.001 in.).

10.3.3 *Lateral Deflection*—Attach two deflectometers, one to each edge of the specimen, as shown in Fig. 2. Record the readings, when the image of the wire coincides with the wire, to the nearest 0.25 mm (0.01 in.). Lateral deflection (if any) may be caused by nonaxial loading of the specimen.

10.4 *Calculations and Report*—For tensile loads, the calculations and report shall be similar to those required for compressive loads (see 9.4).

11. Transverse Load—Specimen Horizontal

11.1 *Test Specimens*—Tests shall be made on three like specimens on symmetrical assemblies and six like specimens on unsymmetrical assemblies, each having a length equal to the length of the element and a nominal width of 1.2 m (4 ft) (see Section 3).

11.2 *Apparatus*—The apparatus shall be assembled as shown in Fig. 3 and shall conform to the detailed requirements for component parts prescribed in 11.2.1-11.2.3, or the equivalent.

11.2.1 *Supports*—Two steel rollers with a steel plate between each supporting roller and the specimen.

11.2.2 *Loading Assembly*—Two steel rollers with a steel plate between each loading roller and the specimen.

11.2.3 *Deflection Gage*—A frame shall be placed on the upper face of the specimen. To prevent stresses deforming the frame as the specimen deforms under load, this frame shall rest on three hardened steel balls each supported by a steel block on the face of the specimen. Two of the balls shall be placed in a line vertically above one support and the third ball vertically above the other support. Two deflection—measuring devices, one near each longitudinal edge of the specimen, shall be attached to the frame at midspan. The spindles shall rest on the upper face of the specimen. The devices shall be graduated to 0.025 mm (0.001 in.) or less.

11.3 Procedure:

11.3.1 *Loading*—Use “two-point” loading for transverse load tests. Test the specimen as a simple beam (Fig. 3) on a span 150 mm (approximately 6 in.) less than the specimen length. Apply two equal loads, each at a distance of one quarter of the span from the supports, toward the middle of the span. For wall specimens tested horizontally (Fig. 3), the load on the specimen shall include the weight of specimen between the supports. Apply the transverse loads to the outside face for three of the specimens and to the inside face for three of the specimens. For symmetrical assemblies, test only three specimens.

11.3.1.1 Uniformly distributed loading may be used instead of quarter-point loading, if a satisfactory method is available. The transverse strength for any span may be greater for some constructions under uniformly distributed load than under loads applied at the quarter-points of the span. Transverse load, uniformly distributed, may be applied by air pressure, either in a bag or in a chamber having the specimen as one face. Support specimens tested under uniform loading by rollers as for quarter-point loading.

11.3.1.2 The bag method of loading is shown schematically in Fig. 4. Connect a reaction platform parallel to the face to be loaded and wider than the specimen to the supports by tie rods. Place an airtight bag of rubberized cloth as wide as the

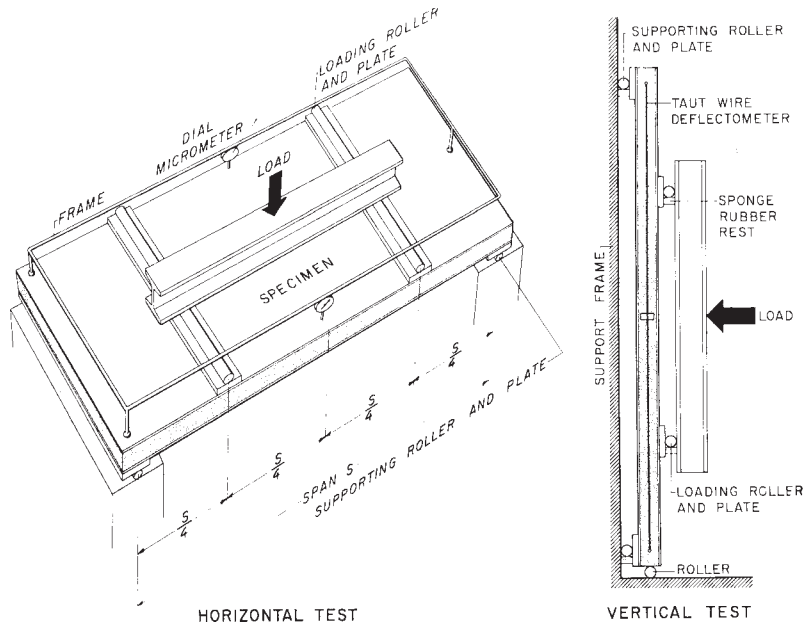

FIG. 3 Transverse Load Test on Wall Specimen

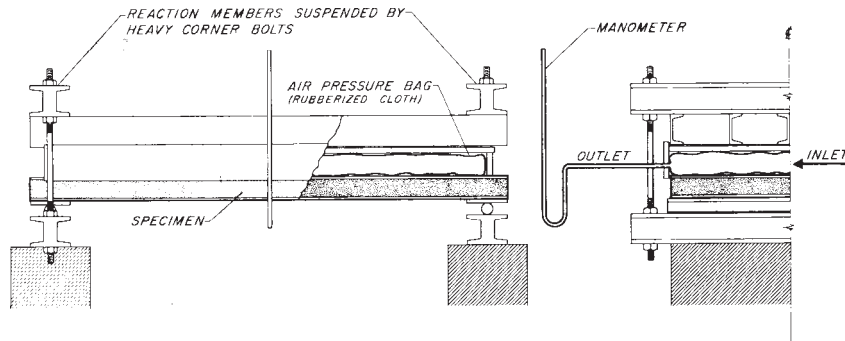

FIG. 4 Apparatus for Uniformly Distributed Transverse Load (Bag Method)

specimen and as long as the span between the specimen and the reaction platform. Apply transverse load to the specimen by increasing the air pressure in the bag. Measure the pressure by means of a manometer. Water is usually the liquid in the manometer, but the specific gravity of the liquid shall be such that the error in pressure readings does not exceed 1 %.

11.3.1.3 When the chamber method of loading is used with the specimen horizontal, place the specimen near the floor, which should be practically airtight. An airtight frame or curb shall surround the specimen closely and be about flush with the upper surface of the specimen. A rubber blanket covers the specimen, overlaps the frame, and is sealed so that it is reasonably airtight. Use a small vacuum pump or positive action exhaust blower to reduce air pressure between the specimen and floor. Measure the difference in pressure above and below the specimen by means of a manometer.

11.3.2 *Strength on Short Span*—The transverse strength of any construction increases as the span is shortened. If the strength of the construction for a shorter span is desired, do not compute it, but test the construction on the short span.

11.4 *Calculations and Report:*

11.4.1 *Load-Deflection Data*—For each micrometer, calculate the deflection under a given load as the difference between

the reading to the nearest division of the micrometer when the load is applied and the initial reading. Calculate the deflection of the specimen for the span as the average of the deflections obtained from each of the two micrometers. Calculate the sets under the initial load by using a similar method. Record the maximum load for each specimen.

11.4.2 *Data Presentation*—Report the results in the form of a graph in accordance with Section 6.

12. **Transverse Load—Specimen Vertical**

12.1 *Test Specimens*—Tests shall be made on three like specimens on symmetrical assemblies and six like specimens on unsymmetrical assemblies each having a length equal to the length of the element and a nominal width of 1.2 m (4 ft) (see Section 3).

12.2 *Apparatus*—The apparatus shall be assembled as shown in Fig. 3 and shall conform to the requirements for component parts prescribed in 12.2.1-12.2.5, or the equivalent.

12.2.1 *Steel Channel.*

12.2.2 *Rollers*—Cylindrical rollers, two supporting rollers, two loading rollers.

12.2.3 *Screw Jack.*

12.2.4 *Ring Dynamometer.*

12.2.5 *Deflectometers*—Two taut-wire mirror-scale deflectometers similar to those described in 9.2.2.

12.3 *Procedure*—Transverse loads cannot be applied satisfactorily to some wall constructions, such as masonry, with the specimen in a horizontal position. For such constructions, apply the loads with the specimen in a vertical position, as shown in Fig. 3, thus simulating service conditions. The specimen, on a steel channel, shall rest on cylindrical rollers to prevent restrained end conditions. The axes of the rollers shall be parallel to the faces of the specimen. The two supporting rollers shall be in contact with the vertical surface of the frame and each roller shall rest horizontally on sponge rubber about 10 mm (0.4 in.) thick to prevent longitudinal restraint. Each of the two loading rollers shall also rest on sponge rubber. Apply the loads horizontally by a screw jack and measure by a ring dynamometer between the jack and the specimen. The error in the load indicated by the dynamometer shall not exceed 1%. Attach two taut-wire mirror-scale deflectometers to the specimen, one to each vertical edge.

12.3.1 Apply the transverse load to the outside face for three of the specimens, and to the inside face for three of the specimens. For symmetrical assemblies, test only three specimens.

12.3.2 The bag method of loading is shown schematically in Fig. 4. Connect a reaction platform parallel to the face to be loaded and wider than the specimen to the supports by tie rods. Place an airtight bag as wide as the specimen and as long as the span between the specimen and the reaction platform. Apply transverse load to the specimen by increasing the air pressure in the bag. Measure the pressure by means of a manometer or other pressure measuring device. The error of the pressure reading shall not exceed 1%.

12.3.3 When the Chamber Method of loading is used with the specimen vertical, the specimen forms one face of an airtight chamber from which the air is exhausted. If all four edges of the specimen bear on the chamber, this loading determines the strength of the specimen as a plate supported at the four edges, not the transverse strength as defined in these methods.

12.3.4 If a specimen tested by the chamber method, either horizontally or vertically, has an airtight cavity, vent each cavity to the low-pressure face by a hole in the face of the specimen not less than 5 mm (0.2 in.) in diameter, located where it will least affect the transverse strength of the specimen.

12.4 *Calculations and Report*—Calculate the results of test and report as described in 11.4, and report deflectometer readings to the nearest 0.25 mm (0.01 in.).

13. Concentrated Load

13.1 *Test Specimens*—Concentrated load tests shall be made on each transverse specimen after the transverse load tests, the concentrated load being applied to the same face to which the transverse load was applied.

13.2 *Apparatus*—The apparatus shall be assembled as shown in Fig. 5 and shall conform to the requirements for component parts prescribed in 13.2.1-13.2.3, or the equivalent.

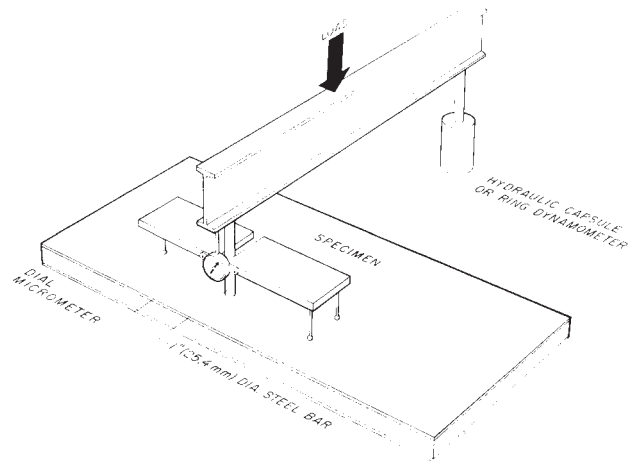

FIG. 5 Concentrated Load Test

13.2.1 *Steel Bar*—Steel bar having a diameter of 25.4 mm (1 in.) and the edge of the face contacting the specimen rounded to a radius of 1.3 mm (0.05 in.).

13.2.2 *Depth Gage*—The depth gage shall consist of a deflection—measuring device graduated to 0.025 mm (0.001 in.) or less mounted on a three-legged support. The support shall be notched to permit placing the device directly adjacent to the bar and shall be long enough to permit placing the supporting legs on undisturbed areas of the face of the specimen.

13.2.3 *Loading Device*—Any convenient means for applying a compressive load up to 5 kN (1100 lbf) and means for measuring the load within 1%.

13.3 Procedure:

13.3.1 *Loading*—Place the entire specimen or portion of the specimen on a horizontal support and properly level. Place the steel bar on the face of the specimen at what is judged to be the weakest place and, also, at what is judged to be the strongest place. Apply a load vertically downward to the upper surface of the bar. Continue loading until maximum load or 4.45 kN (1000 lbf) is attained.

13.3.2 *Depth of Indentation*—Measure the depth of indentation, by means of the depth gage, and record the reading of the micrometer to the nearest 0.025 mm (0.001 in.).

13.4 Calculations and Report:

13.4.1 *Depth of Indentation*—Calculate the depth of indentation (set) after a given load has been applied and the bar removed to the nearest 0.025 mm (0.001 in.) as the difference between the depth for that load and the initial reading of the micrometer before a load has been applied to the specimen.

13.4.2 *Data Presentation*—Report the results in the form of a graph in accordance with Section 6.

14. Racking Load—Evaluation of Sheathing Materials on a Standard Wood Frame

NOTE 2—If the test objective is to measure the performance of the complete wall, Method E 564 is recommended.

14.1 *Scope*—This test method measures the resistance of panels, having a standard wood frame, and sheathed with sheet materials such as structural insulating board, plywood, gypsum board, transite, etc., to a racking load such as would be

imposed by winds blowing on a wall oriented at 90° to the panel. It is intended to provide a reliable, uniform procedure for determining the resistance to racking load provided by these sheet materials as commonly employed in building construction. Since a standard frame is employed, the relative performance of the sheathing is the test objective.

14.1.1 This test is conducted with standardized framing, loading procedures, and method of measuring deflection, as detailed in the method to ensure reproducibility. Provision is made for following the sheathing manufacturers' recommendations for attaching the sheathing to the frame, and for reporting the behavior of the specimen over its entire range of use.

14.1.2 In applying the results, due allowance shall be made for any variation in construction details or test conditions from those in actual service.

14.2 Test Specimens:

14.2.1 Size and Number—The test specimen shall be 2.4 by 2.4 m (8 by 8 ft) and the framing shall be constructed as shown in Fig. 6 and a minimum of three panels of each construction shall be tested. It is the intent of this test procedure to evaluate the stiffening effect of the sheathing material; therefore, the frame shall be constructed as nearly like the frames shown in

Fig. 6 as possible. Frames shall be newly constructed for each test. All individual framing members shall be continuous. The moisture content of framing material shall be between 12 and 15 % when the panel is fabricated, and shall not vary by more than 3 % from the initial moisture content when the panel is tested.

14.2.2 Application of Sheathing—The method of applying the sheathing shall be exactly as specified by the manufacturer. The spacing of fasteners shall be as recommended. Fasteners shall be driven through the sheathing into only the outside stud of each corner post shown in Fig. 6. The importance of the attachment of sheathing to the framing cannot be overemphasized. Slight differences in edge clearances, angle of fastener, and amounts of penetration of heads of fasteners into the sheathing have appreciable effects on the results of test. Unless otherwise specified, fasteners shall be driven perpendicular to the surface of the sheathing with the center of each fastener the specified distance from the edge of the sheathing. Fasteners shall be driven so that the head of the fastener contacts the surface of the sheathing but not so deep as to crush the surface, unless specified differently by the manufacturers.

14.3 Apparatus—The apparatus shall be assembled as shown in Fig. 7. Load shall be measured by means of a testing

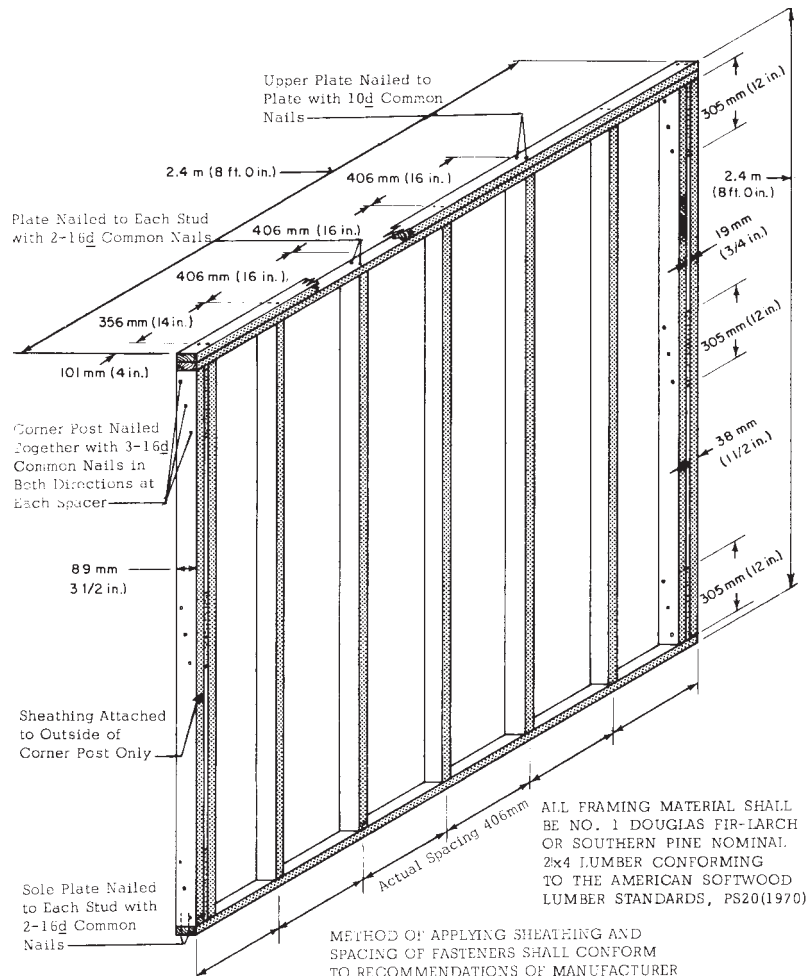

NOTE 1—To eliminate test data that may be misleading, use lumber of average density for the specimens involved.

FIG. 6 Standard Wood Frame

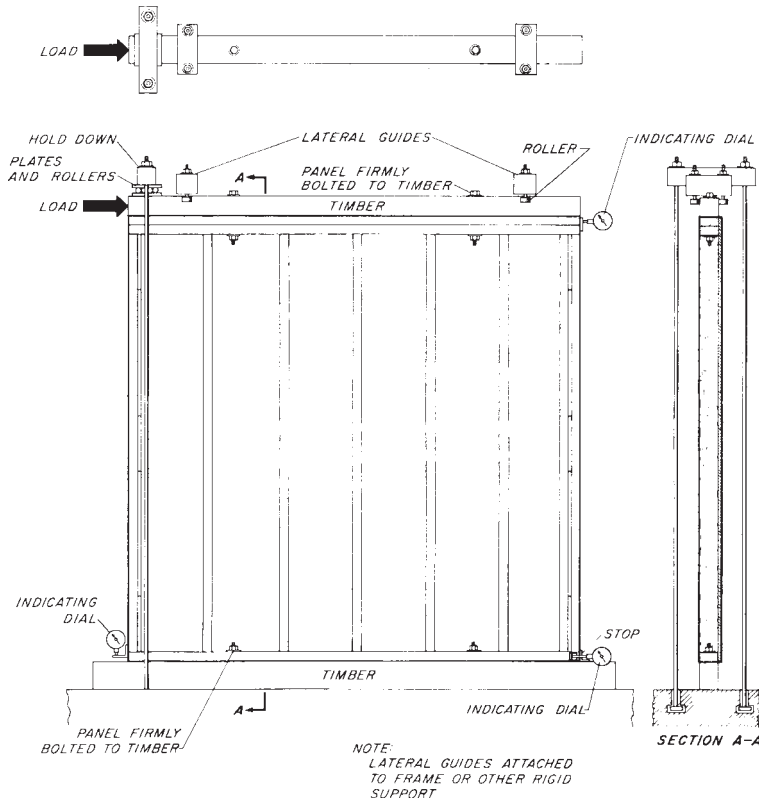

FIG. 7 Racking Load Assembly

machine, or a dynamometer attached to cables that load the specimen, or in linkage with a hydraulic jack used to apply load. The essential parts of the testing apparatus, exclusive of the loading frame, are as described in 14.3.1-14.3.5.

14.3.1 *Base and Loading Frame*—The test panel shall be attached to a timber or steel plate that is in turn attached rigidly to the base of the loading frame in such a manner that when the panel is racked, the sheathing will not bear on the loading frame. This member may be of any convenient cross section, but it shall be at least as long as the panel and not greater in width than the thickness of the frame, 89 mm (3½ in.). Means shall be provided to bolt or otherwise attach the sole plate of the panel firmly to this member. For illustrative purposes, two bolts are shown in Fig. 7. More may be used if required.

14.3.2 *Hold-Down*—A hold-down shall be provided as shown in Fig. 7 to overcome the tendency of one end of the panel to rise as the racking load is applied. Plates and rollers shall be provided between the test specimen and the hold-down so that the top of the specimen can deflect horizontally with respect to the bottom without unnecessary interference from the hold-down. Because the amount of tension in the rods of the hold-down may have an effect on the results of the test, nuts on the hold-down rods shall be tightened prior to load application so that the total force in each rod does not exceed 90 N (20 lbf) at the beginning of test as determined by previous calibration.

14.3.3 *Loading Apparatus*—Load shall be applied to the specimen through an 89 by 89-mm (3.5 by 3.5-in.) timber firmly bolted to the upper plates of the panel. Loading shall be a compressive force against the end of the timber attached to

the upper plate. When a testing machine is used, pulleys and cables may be used to transmit the vertical movement of the tension head of the machine to the horizontal movement in the specimen.

14.3.4 *Lateral Guides*—Lateral guides shall be provided so that the specimen will deflect in a plane. The rollers should be bearing-supported to reduce friction to a minimum. The lateral guides shall be firmly attached to the loading frame. Plates for the rollers may be up to 300 mm (12 in.) in length as required.

14.3.5 *Deflection—Measuring Device*—Deflection—measuring devices, indicating dials, or scales and wires, shall be provided to measure the displacement of the different parts of the panel during test. The readings shall be recorded to the nearest 0.25 mm (0.01 in.). The locations of the deflection—measuring devices shall be as shown in the lower left, lower right, and upper right corners of the side view of the test assembly in Fig. 7. The device at the lower left, which is attached to the stud, measures any rotation of the panel, the device at the lower right measures any slippage of the panel, and the device at the upper right measures the total of the other two plus the deformation of the panel. Therefore, the horizontal deflection of the panel at any load is the reading of the device at the upper right less the sum of the readings of the other two.

14.4 *Procedure:*

14.4.1 *Loading*—Apply the load continuously throughout test at a uniform rate of motion of the loading device used. The recommended speed of testing shall be such that the loading to 3.5 kN (790 lbf) total load shall be completed in not less than 2 min from the start of the test. The loading to 7.0 to 10.5 kN (1570 to 2360 lbf) total load and to failure shall employ the

same rate of travel of the loading device as for the loading to 3.5 kN. Give the speed of testing used in the report of test.

14.4.2 *Loading Procedure*—Load the specimen in three stages to 3.5, 7.0, and 10.5 kN (790, 1570, and 2360 lbf) total load at a uniform rate.

14.4.2.1 To provide data to meet performance requirements, other values of total load may be included in the test procedure. Use the same rate of loading as for the loadings specified and indicate additional loadings evaluated and the results obtained in the report.

14.4.2.2 After the load of 3.5 kN (790 lbf) is placed on the specimen, remove all of the load and any residual deflection (set) in the panel noted. Then load the specimen to 7.0 kN (1570 lbf) and again remove the load and note any additional set; after this increase the loading to 10.5 kN (2360 lbf), remove the load again, and note the set. Apply load continuously for each of the increment loads specified above and obtain load-deflection data. Obtain these data for at least each 900 N (200 lbf) of loading. Obtain deflections during the loading cycle and, if desired, during the unloading cycle as well.

14.4.2.3 After the specimen is loaded as specified to 3.5, 7.0, and 10.5 kN (790, 1570, and 2360 lbf) load it again to failure or until the total deflection of the panel becomes 100 mm (4 in.). Obtain readings of deflection for the same intervals of load as were used for the other loadings.

14.5 *Calculations and Report:*

14.5.1 *Deformation*—For each dial, or other measuring device, calculate the movement under each racking load as the difference between the readings when load is applied and the initial readings at the start of the test. Calculate set readings as the difference between the readings when the load is removed and the initial readings.

14.5.2 *Data Presentation*—Report the deflections at 3.5, 7.0, and 10.5 kN (790, 1570, and 2360 lbf) and the set after loading to these amounts. Present load-deflection curves obtained during loading to failure and to 3.5, 7.0, and 10.5 kN in the form of a graph as prescribed in Section 6. Include maximum load and any observations on the behavior of the panel during test and at failure. Express residual deflections (sets) as percentages of the deflections that produced the sets as well as in millimetres or inches. If the specimen fails, describe the visible failure. If the specimen has been subjected to any special conditioning prior to test, describe this treatment in detail. Describe in the report the sheathing used, the method of applying the sheathing, the type and spacing of fasteners, and the method and rate of loading employed.

15. Racking Load—Evaluation of Sheathing Materials (Wet) on a Standard Wood Frame

15.1 *Scope*—This test has been developed to simulate the degree of wetting possible during construction of a structure when, because of rain, the framing and sheathing may be wetted on one or both sides. Both sides of the wall panel are wetted because this represents the maximum exposure possible during the stage of construction before the structure is roofed.

15.2 *Test Specimens*—The test specimens shall conform in size and fabrication details to the requirements of 14.2.

15.3 *Specimen Conditioning*—Mount the fabricated test specimens or suspend them in a vertical position in such a manner as to prevent continuous immersion of the bottom edge of the specimen. Expose both sides of the test specimen to a water spray applied at or near the top along the entire length to ensure that the top of the specimen is being wetted. The spray shall have no jet action that cuts into the sheathing material, and the spray areas shall overlay sufficiently so that a continuous sheet of water flows down both surfaces of the specimen. Maintain the temperature of the water in the line to the spray nozzle at $24 \pm 3^\circ\text{C}$ ($75 \pm 5^\circ\text{F}$). Wet the specimens for a period of 6 h and then allow to dry for a period of 18 h. Dry in laboratory air, preferably at a temperature of $24 \pm 3^\circ\text{C}$ ($75 \pm 5^\circ\text{F}$). Make no attempt to increase the air movement over the specimens by fans or blowers. Subject the test specimens to two complete wetting and drying cycles and then a third wetting cycle.

15.3.1 No more than 2 h shall elapse between the completion of the third wetting cycle and the start of the racking test.

15.4 *Procedure*—Test the specimens in accordance with the procedure described in 14.4.

15.5 *Moisture Content Determination*—After the racking test is completed, cut moisture samples from the sheathing material, and determine moisture content on a weight basis with the moisture content expressed as a percentage of the oven dry weight in accordance with 15.5.1. Preferably, take five moisture content samples at least 100 by 150 mm (4 by 6 in.) in size from each 1.2 by 2.4-m (4 by 8-ft) sheathing panel of the test specimen: one from the center of each sheathing panel at the top and bottom edges, one from midlength on each side, and one from the panel center. Weigh the moisture content samples immediately upon being cut from the test specimen to an accuracy of not less than $\pm 0.2\%$. Carefully remove all loose particles from the sample before weighing. Then dry the samples to constant weight in an oven at $103 \pm 2^\circ\text{C}$ ($217 \pm 4^\circ\text{F}$). If large amounts of volatile matter or substances other than free water are removed from the sheathing material by drying at $103 \pm 2^\circ\text{C}$, the sheathing material may be dried to constant weight at a lower temperature and the drying time and temperature given in the report.

15.5.1 *Calculation*—Calculate the moisture content as follows:

$$M = 100 [(W - F)/F] \quad (1)$$

where:

M = moisture content, %,

W = initial weight, and

F = final weight when oven dry.

15.6 *Calculations and Report*—The report shall include the racking test data as specified in 14.5. It shall also include the line temperature of the water sprayed on the test specimens; the air temperature and relative humidity during the drying portion of the cycle; and the location of the moisture content samples and the moisture content of each.

TESTING FLOORS

16. Significance and Use

16.1 The procedures outlined will serve to evaluate the performance of floor segments under conditions representative of those sustained in service. Performance criteria based on data from these procedures can ensure structural adequacy and effective service.

17. Transverse Load

17.1 *Test Specimens*—Tests shall be made on three like specimens, each having a length equal to the length of the floor panel and a nominal width of 1.2 m (4 ft) (see Section 3).

17.2 *Apparatus*—The apparatus shall conform to the requirements of 11.2.

17.3 *Procedure*—Conduct the test in accordance with 11.3 on transverse load tests of walls, except apply the loads only to the upper (finish floor) face of the specimen. If practicable, test floor specimens in the horizontal position. If tested in the vertical position, conduct the test in accordance with 12.1-12.4 on transverse load tests on walls in the vertical position. If tested in the vertical position, deduct transverse load equal to the weight of the specimen from each recorded load to obtain the applied load on the specimen.

17.3.1 *Strength on Short Span*—The transverse strength of any floor construction increases as the span is shortened. If the strength of the construction for a shorter span is desired, do not compute it, but test the construction on the shorter span.

17.4 *Calculations and Report*—Report the results as indicated in 11.4.

18. Concentrated Load

18.1 *Test Specimens*—Tests shall be made on each of the transverse specimens after the transverse tests are completed.

18.2 *Apparatus*—The apparatus shall conform to the requirements of 13.2.

18.3 *Procedure*—Conduct the test in accordance with 13.3 on concentrated load tests on walls, except apply the loads only to the upper (finish floor) face of the specimen.

18.4 *Calculations and Report*—Report the results as indicated in 13.4.

TESTING ROOFS

19. Significance and Use

19.1 These procedures will serve to evaluate performance of roof segments under simulated service conditions. Roof trusses shall be evaluated under Methods E 73.

20. Transverse Load

20.1 *Test Specimens*—Tests shall be made on three like specimens, each having a length equal to the length of the roof panel and a nominal width of 1.2 m (4 ft) (see Section 3).

20.2 *Apparatus*—The apparatus shall conform to the requirements of 11.2.

20.3 *Procedure*—Conduct the test in accordance with 11.3 on transverse load tests of walls, except normally apply the loads only to the upper (weatherproofed) face of the specimen. The transverse strength of a roof construction under loads acting outward may appear to be less than the strength under loads acting inward. For such constructions, apply loads acting outward to specimens.

20.3.1 *Strength on Short Span*—The transverse strength of any roof construction increases as the span decreases. If the strength of the construction for a shorter span is desired, do not compute it, but test the construction on the shorter span.

20.4 *Calculations and Report*—Report the results as indicated in 11.4.

21. Concentrated Load

21.1 *Test Specimens*—Tests shall be made on each of the transverse specimens after the transverse tests are completed.

21.2 *Apparatus*—The apparatus shall conform to the requirements of 13.2.

21.3 *Procedure*—Conduct the test in accordance with 13.3 on concentrated load tests of walls, except apply the loads only to the upper (weatherproofed) face of the specimen.

21.4 *Calculations and Report*—Report the results as indicated in 13.4.

22. Keywords

22.1 compressive load; concentrated loads; deformation; floors; load duration; racking load; roofs; sheathing; strength tests; tensile load; transverse load; walls

APPENDIX

(Nonmandatory Information)

X1. TECHNICAL INTERPRETATION

X1.1 It is the purpose of these test methods to provide a systematic basis for obtaining comparable engineering data on various construction elements and structural details of value to designers, builders, building officials, and others interested in this field.

X1.2 Subjecting complete structures to known loads is very expensive and requires much time; therefore, that method of carrying out investigations to establish structural properties is

not likely to be used to any great extent. Such tests have the further disadvantage that only the strength of the weakest elements of a particular structure could be measured.

X1.3 For these reasons, it seems more practicable to apply loads to specimens that accurately reproduce a structural portion of a finished building. These portions of a building have been designated as “elements”; for example, floor, wall, roof, etc. For the procedure described in these test methods, the

elements have been restricted to those most important structurally. For each element, methods of loading are described that simulate the loads to which the element would be subjected under service conditions. It is believed that the results of these measurements on the structural elements will be more useful to architects and engineers than the results of tests on specimens of the materials from which the structure was fabricated, or the results of tests of the individual structural members. Although it may be impracticable to determine all of the structural properties of each element of a building, it is believed that the more important properties may be determined by tests described in these test methods.

X1.4 The test method, involving the application of the loads in increments and the concurrent measurement of deformation and set, simulates, to some extent, the conditions of repeated loading under service conditions. Therefore, results by such a method of loading may be more useful than those obtained by increasing the load continuously throughout the test. The results from increment loading tests may show whether different portions of a construction act as a unit under load, whether the fastenings or bonds have adequate strength, or whether they rupture under repeated loads. For any engi-

neering structure, including small houses, it is necessary not only that the strength be adequate, but also that the deformation under load shall not appreciably decrease the usefulness of the structure. If the working load and the allowable deformation for an element for a structure are known, constructions complying with these requirements may be selected by inspection of the graphs from tests of such constructions.

X1.5 A structure is elastic if, after a load has been applied and then removed, the set is inappreciable. If the set is small for an element of a building, it may be assumed that the construction has neither been damaged nor appreciably deformed by the load. The set, therefore, is another property that may be used when comparing different constructions and may be useful when selecting a construction for a particular purpose.

X1.6 The variations in the properties of a construction as used commercially for buildings, in all probability, will be greater than the variations for the three specimens tested as directed in these test methods because these specimens will be all fabricated at the same time by the same workmen and from the same lot of material. This fact should be clearly indicated in any general report based on these test procedures.

ASTM International takes no position respecting the validity of any patent rights asserted in connection with any item mentioned in this standard. Users of this standard are expressly advised that determination of the validity of any such patent rights, and the risk of infringement of such rights, are entirely their own responsibility.

This standard is subject to revision at any time by the responsible technical committee and must be reviewed every five years and if not revised, either reapproved or withdrawn. Your comments are invited either for revision of this standard or for additional standards and should be addressed to ASTM International Headquarters. Your comments will receive careful consideration at a meeting of the responsible technical committee, which you may attend. If you feel that your comments have not received a fair hearing you should make your views known to the ASTM Committee on Standards, at the address shown below.

This standard is copyrighted by ASTM International, 100 Barr Harbor Drive, PO Box C700, West Conshohocken, PA 19428-2959, United States. Individual reprints (single or multiple copies) of this standard may be obtained by contacting ASTM at the above address or at 610-832-9585 (phone), 610-832-9555 (fax), or service@astm.org (e-mail); or through the ASTM website (www.astm.org).