



Designation: E 736 – 9200

An American National Standard

# Standard Test Method for Cohesion/Adhesion of Sprayed Fire-Resistive Materials Applied to Structural Members<sup>1</sup>

This standard is issued under the fixed designation E 736; the number immediately following the designation indicates the year of original adoption or, in the case of revision, the year of last revision. A number in parentheses indicates the year of last reapproval. A superscript epsilon ( $\epsilon$ ) indicates an editorial change since the last revision or reapproval.

~~$\epsilon$ <sup>1</sup> NOTE — The committee is in the process of balloting to revise paragraph 5.2 and add an explanatory note to paragraph 8.3.3.~~

## 1. Scope

1.1 This test method covers a procedure for measuring the cohesion/adhesion or bond strength (tensile) perpendicular to the surface of sprayed fire-resistive material (SFRM) applied to rigid backing. These fire-resistive materials include sprayed fibrous and cementitious materials. The test method is applicable to both laboratory and field procedures as indicated in Section 7.

1.2 The values stated in SI units are to be regarded as the standard. The values in parentheses are for information only.

1.3 *This standard does not purport to address all of the safety problems, if any, associated with its use. It is the responsibility of the user of this standard to establish appropriate safety and health practices and determine the applicability of regulatory limitations prior to use.*

## 2. Referenced Documents

2.1 *ASTM Standards:*

<sup>1</sup> This test method is under the jurisdiction of ASTM Committee E-6 on Performance of Buildings and is the direct responsibility of Subcommittee E06.21 on Serviceability. Current edition approved Nov. 15, 1992; April 10, 2000. Published January 1993; July 2000. Originally published as E 736 – 80. Last previous edition E 736 – 86 (1991). E 736 – 92.

- E 84 Test Method for Surface Burning Characteristics of Building Materials<sup>2</sup>
- E 119 Test Methods for Fire Tests of Building Construction and Materials<sup>2</sup>
- E 605 Test Methods for Thickness and Density of Sprayed Fire-Resistive Material (SFRM) Applied to Structural Members<sup>2</sup>

**3. Summary of Test Method**

3.1 The cohesion/adhesion is determined using a metal or plastic cap with a hook attached. The cap is attached to the SFRM with a suitable adhesive. An increasing load, measured by a scale, is applied manually until failure occurs.

**4. Significance and Use**

4.1 The intent of this test method is to determine a property of SFRM that may be used to provide an indication of its in-place serviceability. Satisfactory performance of SFRM applied to structural members and assemblies depends upon its ability to withstand the various influences that may occur during construction and during the life of the structure, as well as upon its satisfactory performance under fire conditions.

**5. Apparatus**

- 5.1 Fig. 1 illustrates a suitable apparatus.
- 5.2 *Bottle Screw Cap*,<sup>3</sup> metal or rigid plastic 51 mm to 83 mm (2 in. to 3¼ in.) in diameter and 12 mm (½ in.) in nominal depth. A hook shall be attached at the center. Where deck profile does not allow the use of an 83-mm (3¼-in.) diameter cap due to area restriction, a minimum 51-mm (2-in.) diameter cap shall be used.
- 5.3 *Adhesive*, single or two component, suitable for adhering cap to SFRM.<sup>4</sup>
- 5.4 *Weighing Scale*, spring type (fish hook), with a capacity suitable for the SFRM being tested (typically 12 kg to 30 kg (26 to 66 lb) capacity). The accuracy shall be within 0.1 kg (¼ lb).
- 5.5 *Galvanized Steel Sheet*, 1.5 mm (0.060 in. (16 ga)) thick, 300 mm (12 in.) square, cleaned with solvent to remove any oil from surface to be sprayed.
- 5.6 *Drying Oven*, capable of maintaining temperature and humidity conditions during the specimen curing cycle, in accordance with the SFRM manufacturers’ published requirements.

**6. Sampling**

- 6.1 This test method requires the application of SFRM in accordance with manufacturers’ published instructions. The apparatus, materials, and procedures used to spray apply the SFRM for this test shall be representative of application in the field.
- 6.2 The density of the prepared specimens shall be similar to the density tested and reported during the Test Methods E 119 and E 84 fire exposure tests of the same material, or as required by the sponsor of the test.
- 6.3 Determine and report in accordance with Test Methods E 605 the density and thickness of each sample, or of a randomly selected specimen from the sample lot when a number of identical samples are being tested for the laboratory-prepared samples. For the field specimens, determine the density from material adjacent to the test specimen.

**7. Test Specimen**

- 7.1 *Laboratory Tests:*
  - 7.1.1 The SFRM shall be applied at a thickness of 12 mm to 25 mm (½ in. to 1 in.) to the 300 by 300 mm (12 by 12 in.) galvanized steel sheet.

<sup>2</sup> Annual Book of ASTM Standards, Vol 04.07.  
<sup>3</sup> Refer to Appendix X1.2 for a list of bottle screw caps from the following scientific cap supply houses that have been found satisfactory for this purpose: CSC Co., Inc., Chicago, IL 60623; Arthur H. Thomas, Philadelphia, PA; and SGA Scientific Inc., Bloomfield, NJ 07003; purpose. Many local suppliers are also available.  
<sup>4</sup> Suitable adhesives are commercially available. Refer to Appendix X1.1 for a list of adhesive supply houses that have been found satisfactory for this purpose.

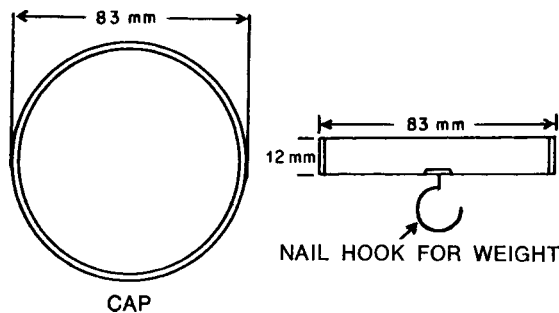

**FIG. 1 Typical Cohesion/Adhesion Testing Apparatus**

7.1.2 Condition the specimen at room temperature ( $20 \pm 10^\circ\text{C}$  ( $68 \pm 18^\circ\text{F}$ )). After 72 h, samples may be force dried in a drying oven at  $43 \pm 6^\circ\text{C}$  ( $110 \pm 10^\circ\text{F}$ ), and a relative humidity not greater than 60 % until successive weight<sup>5</sup> readings, taken at 8 h intervals, differ by less than 1 percent.

7.1.3 Testing may be performed after it has been determined that all samples have reached constant weight as defined in 7.1.2.

**7.2 Field Tests:**

7.2.1 The test specimen shall be the in-place SFRM as applied to any field condition surface. Where a 300 by 300 mm (12 by 12 in.) area is not available, such as on beams and fluted deck, use the width of the beam or the width of a flute by 300 mm (12 in.) length. The area shall be at least 100 by 300 mm (4 by 12 in.). See 5.2 for exceptions.

7.2.2 Condition the specimen at atmospheric conditions or in accordance with the manufacturers' recommendations for a period sufficient to be considered dry.

7.2.3 Mechanical ventilation may be employed on the manufacturers' recommendation to expedite drying.

**8. Procedure**

8.1 Apply adhesive sufficient to fill the metal or plastic cap, and immediately place the cap against the surface of the SFRM. Refer to Fig. 2.

8.2 Support the cap at the surface until the adhesive has adequately cured. Wipe away any excess adhesive around the cap before it cures, or carefully cut it away after it cures.

**8.3 Laboratory Tests:**

8.3.1 Restrain the specimen with the SFRM facing up to prevent movement and flexing during testing. The orientation of the specimen in Fig. 2 shows the SFRM facing down.

8.3.2 Engage the scale with the hook and exert an increasing force at a minimum uniform or incremental rate of approximately 5 kg (11 lb-)/min perpendicular to the surface.

8.3.3 Force shall be applied until failure occurs, a predetermined value is reached, or until the capacity of the scale is reached.

8.3.4 Record the force in newtons or (pounds-force) at the time failure occurs or other end point is reached.

**8.4 Field Tests:**

8.4.1 Perform tests as described in 8.3.2-8.3.4.

8.4.2 A non-destructive field test may be performed by replacing the scale (see 5.4) with a fixed weight that must be supported for 1 min.

**9. Calculation**

9.1 Calculate the cohesive/adhesive force (bond strength) as follows:

$$CA = F/A \tag{1}$$

where:

- CA = cohesive/adhesive force, Pa (lbs/ft<sup>2</sup>),
- F = recorded force, N (lbf), and
- A = area of the cap, m<sup>2</sup>(ft<sup>2</sup>).

**10. Report**

10.1 Report the following information:

10.1.1 Force, newtons (or pounds force),

10.1.2 Cohesive/adhesive force (bond strength), pascals (or pounds force per square foot),

10.1.3 Description of the type of failure:

10.1.3.1 Cohesive failure, if separation occurred within the material,

<sup>5</sup> Although *mass* is being determined, the term *weight* is used in the test method as an accepted substitute.

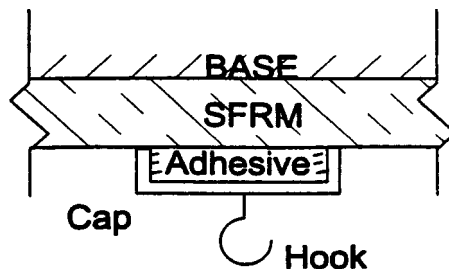

**FIG. 2 In-Place Apparatus**

- 10.1.3.2 Adhesive failure, if separation occurred at the interface of the substrate and the SFRM,
- 10.1.4 Approximate area of material involved in the failure, if it extends beyond the perimeter of the cap,
- 10.1.5 Thickness of the SFRM, millimetres (inches), and
- 10.1.6 Density of the SFRM, kilograms per cubic metre (pounds per cubic foot).

## 11. Precision and Bias

- 11.1 *Precision*—The precision of this test method is being developed and will be added when available.
- 11.2 *Bias*—The procedure on this test method has no bias because the value of the cohesive/adhesive strength can be defined only in terms of a test method.

## 12. Keywords

- 12.1 cohesion/adhesion testing; fire-resistive materials; sprayed materials testing

## APPENDIX

### (Nonmandatory Information)

#### X1. TEST APPARATUS

X1.1 Two-component urethane resin adhesives for use in adhering test caps to SFRM during bond strength testing are available from various sources of supply, including those listed as follows: Contact the adhesive manufacturer to determine product suitability.

Brim Products Co., Inc.  
6531 S.W. 20<sup>th</sup> Court  
Plantation, FL 33317  
(954) 584-1150

C & R Products Co.  
Division of Clothier & Rose, Inc.  
1000 E. Del Amo Blvd.  
Carson, CA 90746  
(310) 537-2800

Fomo Products, Inc.  
2775 Barber Road  
P.O. Box 1078  
Norton, OH 44203  
(330) 753-4585

Insta-Foam Products, Inc.  
1500 Cedarwood Drive  
Joliet, IL 60435  
(815) 741-6800

Clayton Corp./Convenience Products, Inc.  
866 Horan Drive  
Fenton, MO 63026  
(314) 349-5333

Mine Safety Appliance Co.  
Walden Road  
Cranberry Township, PA 16066  
(412) 967-3000

Ohio Sealants, Inc.  
7405 Production Drive  
Mentor, OH 44060  
(216) 951-5678

Red Devil, Inc.  
2400 Vauxhall Road  
Union, NJ 07063  
(908) 688-6900

X1.2 Bottle screw caps are available from various sources of supply, including those listed as follows. Contact the supplier to determine availability of the cap that complies with the requirements outlined herein.

Andler Bottle Co.  
376 Third St.  
Everett, MA 02149  
(617) 387-5700

Thomas Scientific Co.  
99 High Hill Road  
Swedesboro, NJ 08085  
(609) 467-2000

CSC Co., Inc.  
Chicago, IL 60623

Arthur H. Thomas  
Philadelphia, PA

SGA Scientific Inc.  
Bloomfield, NJ 07003

*ASTM International takes no position respecting the validity of any patent rights asserted in connection with any item mentioned in this standard. Users of this standard are expressly advised that determination of the validity of any such patent rights, and the risk of infringement of such rights, are entirely their own responsibility.*

*This standard is subject to revision at any time by the responsible technical committee and must be reviewed every five years and if not revised, either reapproved or withdrawn. Your comments are invited either for revision of this standard or for additional standards and should be addressed to ASTM International Headquarters. Your comments will receive careful consideration at a meeting of the responsible technical committee, which you may attend. If you feel that your comments have not received a fair hearing you should make your views known to the ASTM Committee on Standards, at the address shown below.*

*This standard is copyrighted by ASTM International, 100 Barr Harbor Drive, PO Box C700, West Conshohocken, PA 19428-2959, United States. Individual reprints (single or multiple copies) of this standard may be obtained by contacting ASTM at the above address or at 610-832-9585 (phone), 610-832-9555 (fax), or [service@astm.org](mailto:service@astm.org) (e-mail); or through the ASTM website ([www.astm.org](http://www.astm.org)).*