



Standard Test Method for Accelerated Weathering of Sealed Insulating Glass Units¹

This standard is issued under the fixed designation E 773; the number immediately following the designation indicates the year of original adoption or, in the case of revision, the year of last revision. A number in parentheses indicates the year of last reapproval. A superscript epsilon (ϵ) indicates an editorial change since the last revision or reapproval.

1. Scope

1.1 This test method covers procedures for testing the performance of preassembled permanently sealed insulating glass units against accelerated weathering.

1.2 This test method is applicable only to sealed insulating glass units, with one or two airspaces, fabricated for vision glass areas for use in buildings, such as sliding doors, windows, wall systems, and picture windows.

1.3 The unit construction used in this test method contains dimensions that are an essential component of the test. Deviations of glass or airspace sizes, or both, will affect the test results.

1.4 This test method is not applicable to sealed insulating glass units that are constructed from exterior vision materials other than glass.

1.5 The values stated in SI units are to be regarded as the standard. The values given in parentheses are for information only.

1.6 *This standard does not purport to address all of the safety concerns, if any, associated with its use. It is the responsibility of the user of this standard to establish appropriate safety and health practices and determine the applicability of regulatory limitations prior to use.* A specific hazard statement is given in Note 2.

2. Referenced Documents

2.1 ASTM Standards:

C 1036 Specification for Flat Glass²

¹ This test method is under the jurisdiction of ASTM Committee E-6 E06 on Performance of Buildings and is the direct responsibility of Subcommittee E06.22 on Durability Performance of Building Constructions.

Current edition approved June 10, 1997; 2001. Published August 1997; November 2001. Originally published as E 773 – 81. Last previous edition E 773 – 83 (1995); E 773 – 97.

E 546 Test Method for Frost Point of Sealed Insulating Glass Units³

E 774 Specification for the Classification of the Durability of Sealed Insulating Glass Units³

3. Terminology

3.1 *Definitions of Terms Specific to This Standard:*

3.1.1 *chemical dew point*—the temperature (Note 1) at which organic vapor or other chemical begins to condense on the interior glass surface of a sealed insulating glass unit.

NOTE 1—The temperature as indicated by the temperature indicator of frost point apparatus when constructed and used in accordance with test procedures described in Test Method E 546.

3.1.2 *frost point*—the temperature (Note 1) below freezing point of water (0°C (32°F)) at which visible frost begins to deposit on the interior glass surface of a sealed insulating glass unit.

4. Significance and Use

4.1 This test method is intended to provide a means for evaluating the durability of the sealing system of sealed insulating glass units. A round-robin test has been conducted, and additional data are being collected. The suitability of these test methods will be further evaluated as the analysis of test results is completed.

5. Apparatus

5.1 *For High Humidity Testing:*

5.1.1 *High-Humidity Test Chamber*—A chamber of convenient dimensions capable of maintaining $60 \pm 3^\circ\text{C}$ ($140 \pm 5^\circ\text{F}$) and $95 \pm 5\%$ relative humidity.

5.2 *For Accelerated Weather Cycle Test:*

5.2.1 *Accelerated Weather Cycle Test Apparatus*⁴—The accelerated weather cycle test apparatus shall be essentially that shown in Figs. 1-3 to provide the cycle conditions and time frame indicated in Section 8.

5.2.2 *Ultraviolet Light Source:*

NOTE 2—**Warning:** Ultraviolet light sources used in this test method are harmful, especially to the eyes. Appropriate protective measures must be observed.

5.2.2.1 The source shall consist of two fluorescent black light lamps, Type F72T12BL/HO^{5,6} (Note 3), for each test specimen located as shown in Fig. 3.

5.2.2.2 Each lamp must be replaced when its ultraviolet light intensity falls below 10 kW/m^2 when measured with a long-wave ultraviolet meter⁵ in direct contact with the lamp.

NOTE 3—Rated average life at 3 h per start: 12 000 h. Rated average life at 12 h per start: 18 000 h. Useful length: 1625 mm (64 in.). Wattage: 85 W. Relative black light energy output is 190 % that of F40BL lamp.

6. Test Specimens

6.1 Each test specimen shall measure $356 \pm 6 \text{ mm}$ by $508 \pm 6 \text{ mm}$ ($14 \pm \frac{1}{4} \text{ in.}$ by $20 \pm \frac{1}{4} \text{ in.}$) and shall be composed of two or three panes of clear, tinted or coated annealed, heat-strengthened, tempered or laminated glass.

6.1.1 ~~The thickness of the glass and airspace thickness(es) shall be 4 mm ($\frac{5}{32} \text{ in.}$) glass and 12 mm ($\frac{1}{2} \text{ in.}$) airspace. Alternatively, unit construction can be 5 mm ($\frac{3}{16} \text{ in.}$) or glass with a 6 mm ($\frac{1}{4} \text{ in.}$).~~

6.1.2 ~~The airspace or spaces shall be from nominal 6 in.) airspace.~~

6.1.2 For triple pane units, 4 mm ($\frac{5}{32} \text{ in.}$) through 13 glass and 6 mm ($\frac{1}{4} \text{ in.}$) airspaces are used.

6.1.3 Triple pane units where the intermediate airspace divider is a plastic film are acceptable.

6.2 ~~The thickness tolerance~~

6.1.4 ~~All of the values in 6.1.1 and 6.1.2 are nominal.~~

6.1.5 ~~Tolerance of glass thickness shall conform to be in accordance with Specification C- 1036.~~

6.31.6 ~~Airspace tolerance(s) shall be $\pm 0.8 \text{ mm}$ ($\frac{1}{32} \text{ in.}$).~~

6.1.7 Glass or airspace thickness(es), or both, may be increased. This can result in a more rigorous test.

² Annual Book of ASTM Standards, Vol 15.02.

³ Annual Book of ASTM Standards, Vol 04.11.

⁴ The apparatus is a modification of the device developed by the Division of Building Research of the National Research Council of Canada. The modifications include two black light lamps for each test specimen. Construction details are available from SIGMA (Sealed Insulating Glass Manufacturer's Association), 111 E. Wacker Drive, Chicago, IL 60601.

⁵ The sole source of supply of the apparatus known to the committee at this time is General Electric Co., Nela Park, Cleveland, OH 44112. If you are aware of alternative suppliers, please provide this information to ASTM Headquarters. Your comments will receive careful consideration at a meeting of the responsible technical committee,¹ which you may attend.

⁶ The sole source of supply of the apparatus known to the committee at this time is the Black-Ray UV Meter with J221 sensor cell available from Ultra-Violet Products, Inc., 5100 Walnut Grove Ave., San Gabriel, CA 91778. If you are aware of alternative suppliers, please provide this information to ASTM Headquarters. Your comments will receive careful consideration at a meeting of the responsible technical committee,¹ which you may attend.



FIG. 1 Typical Accelerated Weather Cycle Test Apparatus

6.2 Each specimen shall be permanently and legibly marked with the designation of the manufacturer and the date of fabrication (month and year).

6.43 At least ten specimens of identical component materials and construction shall be submitted.

6.54 During all stages of exposure and storage, the units shall be stored in a vertical position with equal support to all panes and no compression loading.

6.65 Selection of units for testing shall be made at random except for units damaged in transit. Damaged units shall not be tested.

7. Preparation of Test Specimen

7.1 Uncleanable stain or scum may remain on the exterior glass surface of the specimen after the accelerated weathering test. Measures should be taken to have a clear view of the interior glass surface for detection of frost. For example, place a mask of plastic tape⁷ 50 by 50 mm (2 by 2 in.) or larger, on the central region of both exterior glass surfaces. Remove the mask for frost point measurement.

7.2 The sealed insulating glass units shall be sealed a minimum of 4 weeks to allow for stabilization before the high humidity exposure in accordance with 8.1 begins. The manufacturer has the option to waive this requirement.

8. Procedure

8.1 High Humidity Test:

8.1.1 Expose six specimens in the high-humidity test chamber at $60 \pm 3^\circ\text{C}$ ($140 \pm 5^\circ\text{F}$) and $95 \pm 5\%$ relative humidity. Arrange the specimens so that each specimen has at least 6-mm ($\frac{1}{4}$ -in.) clearance all around the four sides. Protect the high humidity chamber from overheating with a protective device.

⁷ The sole source of supply of the apparatus known to the committee at this time is Scotch Plastic Tape # 471 available from 3M Co., 3M Center, Commercial Office Supply Div., Bldg. 230-3 South-17, St. Paul, MN 55101. If you are aware of alternative suppliers, please provide this information to ASTM Headquarters. Your comments will receive careful consideration at a meeting of the responsible technical committee,¹ which you may attend.

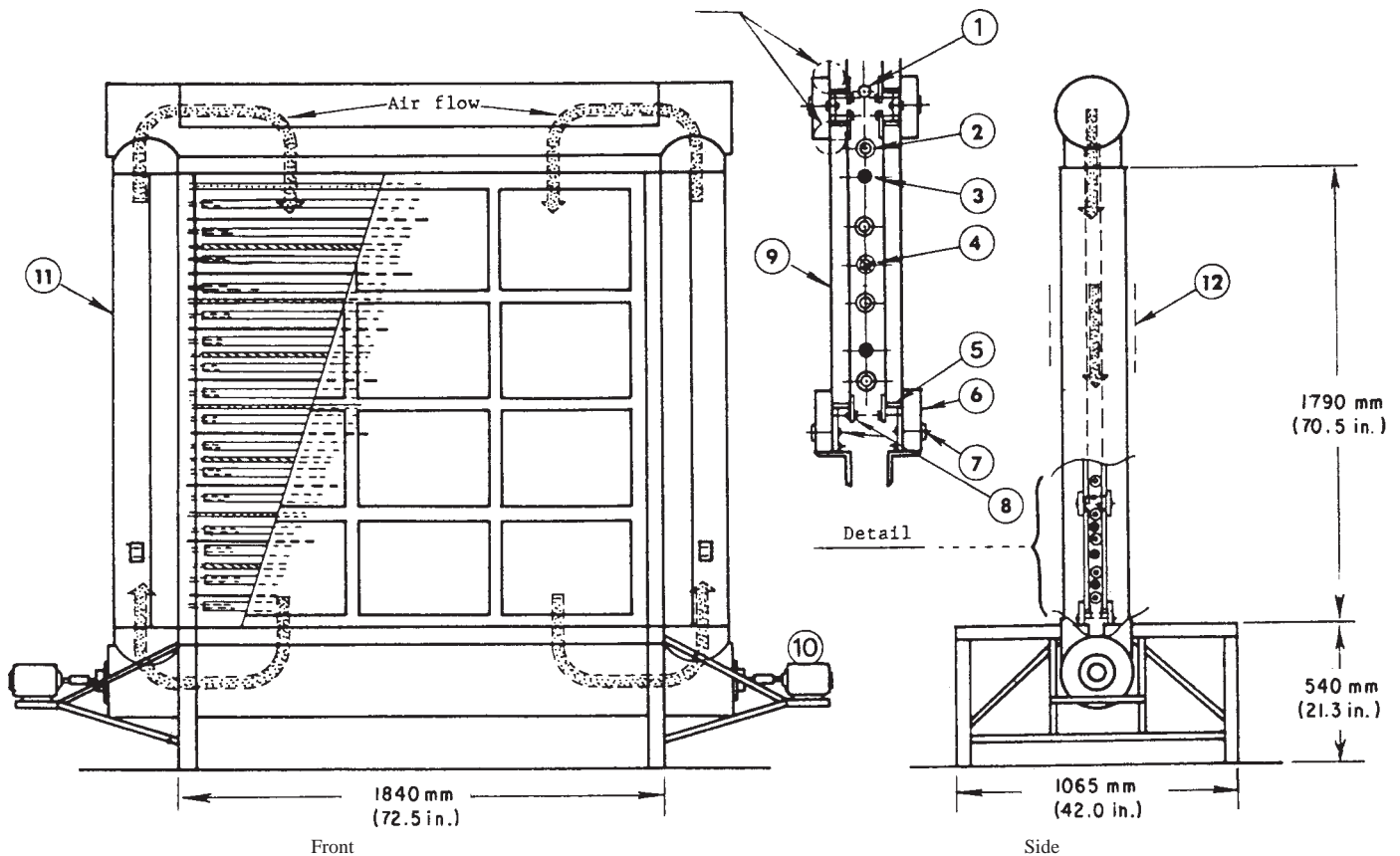

Description: 1. Water spray pipe, 2. Cooling coil, 3. Fluorescent black light lamp, F72T12 BL/HO, 4. Heating coil, 5. Rubber pad, 6. Polystyrene insulation, 7. Rubber washer, 8. Clamping device, 9. Test specimen, 10. Fan motor, 11. Air duct, 12. Insulation.

FIG. 2 Schematic Drawing of Typical Accelerated Weather Cycle Test Apparatus

8.1.1.1 Equip the high humidity chamber with a continuous temperature recording device placed in an area that gives the average temperature in the chamber.

8.1.2 When the specified time period has been attained, remove the test specimens and determine the frost point in accordance with Test Method E 546. Observe for chemical dew point.

8.2 *Accelerated Weather Cycle Test:*

8.2.1 Place the test specimens that were tested in accordance with 8.1 in the accelerated weather cycle test apparatus. Mount the specimens so that one exterior surface of the specimen is exposed to weathering cycles and the other to room temperature (Note 4). Install all specimens as shown in Fig. 2, taking care that no stress is induced in the test specimens by the method of fastening. The test specimens shall be oriented in the accelerated weather cycle exposure with the number one surface facing the weather changes as it does in normal field exposure. Ensure that the bearing edge and the weathering or exposed side remain the same throughout all testing.

NOTE 4—A temperature in the range from 15 to 30°C (60 to 85°F).

8.2.2 *Cycling*—Each cycle shall be 6 h ± 5 min and composed of the following test condition (see Fig. 4):

8.2.2.1 During the first 1 h ± 5 min, decrease the temperature from room temperature to -30 ± 3°C (-20 ± 5°F).

8.2.2.2 Maintain temperature at -30 ± 3°C (-20 ± 5°F) for 1 h ± 5 min.

8.2.2.3 Turn on heat and allow temperature to rise from -30 ± 3°C (-20 ± 5°F) to room temperature over a period of 1 h ± 5 min.

8.2.2.4 Over a time period of 1 h ± 5 min, start water spray and ultraviolet lamps and control the temperature rise from room temperature to 57 ± 3°C (135 ± 5°F). Turn off water spray after 30 min to allow temperature to continue to rise to 57 ± 3°C.

8.2.2.5 Maintain temperature at 57 ± 3°C (135 ± 5°F) and continue ultraviolet exposure for a period of 1 h ± 5 min. Humidity remains very high during this hour; consequently, additional water spray is not necessary.

8.2.2.6 Over a period of 1 h ± 5 min, decrease temperature from 57 ± 3°C (135 ± 5°F) to room temperature, and continue ultraviolet exposure. At the end of this period, turn off ultraviolet exposure.

8.2.2.7 Protect the accelerated weathering chamber from overheating and from overcooling with protective devices.

8.2.2.8 Equip the accelerated weather cycle chamber with a continuous temperature recording device placed in an area that gives the average temperature inside the chamber.

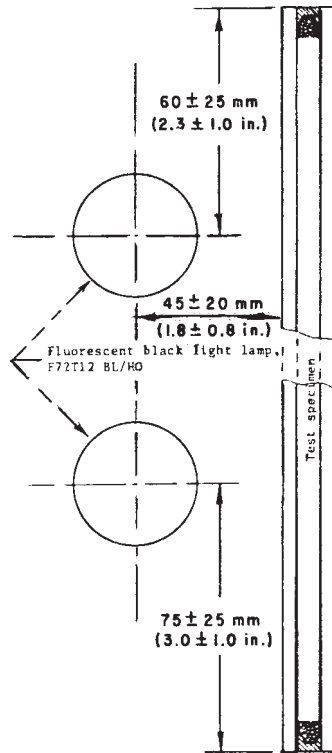
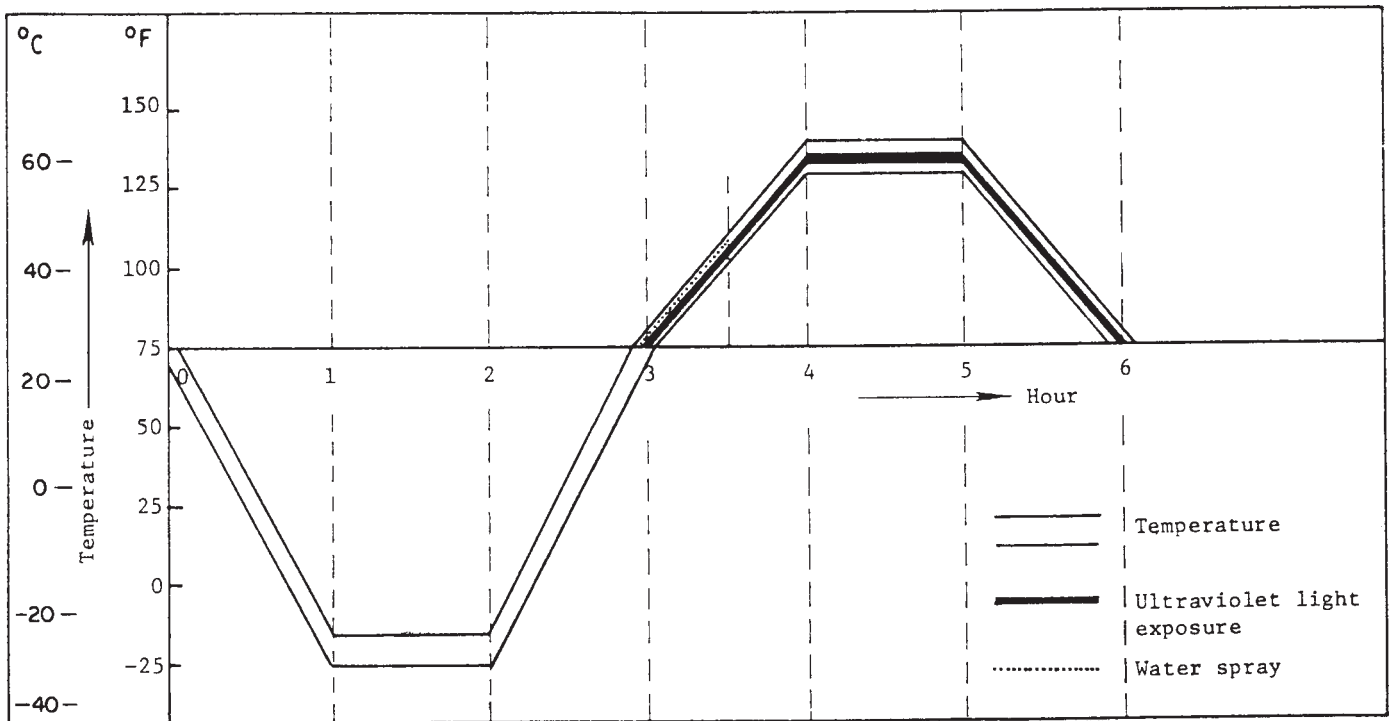

FIG. 3 Location of Fluorescent Black Light Lamp Relative to the Test Specimen



NOTE 1—This figure represents a linear response, but the equipment will not necessarily respond in a linear manner.

FIG. 4 Schematic Drawing of Each Cycle for Accelerated Weather Cycle Test

8.2.3 When the number of cycles prescribed⁸ has been attained, remove the specimens and determine the frost point in accordance with Test Method E 546.

⁸ For insulating glass units, see Specification E 774.

9. Observations

9.1 Observe for the following:

9.1.1 Specimen breakage.

9.1.2 Specimen failure, which is indicated by visible water in the cavity.

10. Report

10.1 Report the following data:

10.1.1 *Complete Description of Specimen Tested:*

10.1.1.1 Dimensions of the test specimen (width by height) and overall thickness.

10.1.1.2 Type and thickness of glass panes.

10.1.1.3 Airspace thicknesses.

10.1.1.4 Describe the spacer composition and configuration.

10.1.1.5 Describe the corner construction including the type and number of corner keys.

10.1.1.6 Dessicant type and quantity, if known, and sealant type.

10.1.1.7 Dimensions of sealant.

10.1.1.8 Manufacturer and manufactured date (month, if known, and year).

10.1.2 *Duration of Test:*

10.1.2.1 Duration of high humidity test described in 8.1 (number of days or weeks).

10.1.2.2 Duration of accelerated weather cycle test described in 8.2 (number of cycles, days or weeks).

10.1.3 Chemical dew point, if observed.

10.1.4 Specimen breakage, if observed.

10.1.5 Massive specimen failure, if observed.

11. Precision and Bias

11.1 *Precision*—The precision of the procedures in Test Method E 773 for measuring accelerated weatherability is being determined.

11.2 *Bias*—Since there is no accepted reference material suitable for determining the bias for the procedures in Test Method E 773 for accelerated weatherability, bias has not been determined.

12. Keywords

12.1 insulating glass units; sealed insulating glass units

ASTM International takes no position respecting the validity of any patent rights asserted in connection with any item mentioned in this standard. Users of this standard are expressly advised that determination of the validity of any such patent rights, and the risk of infringement of such rights, are entirely their own responsibility.

This standard is subject to revision at any time by the responsible technical committee and must be reviewed every five years and if not revised, either reapproved or withdrawn. Your comments are invited either for revision of this standard or for additional standards and should be addressed to ASTM International Headquarters. Your comments will receive careful consideration at a meeting of the responsible technical committee, which you may attend. If you feel that your comments have not received a fair hearing you should make your views known to the ASTM Committee on Standards, at the address shown below.

This standard is copyrighted by ASTM International, 100 Barr Harbor Drive, PO Box C700, West Conshohocken, PA 19428-2959, United States. Individual reprints (single or multiple copies) of this standard may be obtained by contacting ASTM at the above address or at 610-832-9585 (phone), 610-832-9555 (fax), or service@astm.org (e-mail); or through the ASTM website (www.astm.org).