



Standard Guide for Modular Coordination of Clay and Concrete Masonry Units¹

This standard is issued under the fixed designation E 835/E 835M; the number immediately following the designation indicates the year of original adoption or, in the case of revision, the year of last revision. A number in parentheses indicates the year of last reapproval. A superscript epsilon (ϵ) indicates an editorial change since the last revision or reapproval.

This standard has been approved for use by agencies of the Department of Defense.

INTRODUCTION

This guide is issued as a standard for reference in design, specification, manufacture and construction using metric (SI) or inch-pound units. The SI preferred dimensions are based on the internationally recognized building module of 100 mm. The inch-pound preferred dimensions are based on the U.S. recognized building module of 4 inches. Dimensions given in millimeters (mm) apply to units designed for SI use. Dimensions given in inches (in.) apply to units designed for inch-pound use.

This guide is intended to minimize the potential field cutting of units due to the layout requirements of the construction and contract documents. It is not the intent of this guide to restrict or limit the production of units not conforming to modular dimensional coordination.

1. Scope

1.1 This guide covers unit sizes for clay and concrete masonry units laid in mortar for use in buildings and building systems designed in accordance with the principles of modular coordination. Specifically it covers:

- 1.1.1 Sizes of full-size units and supplementary units.
- 1.1.2 Joint thicknesses.
- 1.1.3 Specified dimensions.

1.2 Permissible variations from specified dimensions of masonry units vary with intended use, project requirements and type of product. Thus, permissible dimensional variations for masonry units should be obtained from the appropriate ASTM specification. See Section 2 for a listing of appropriate specifications.

2. Referenced Documents

2.1 ASTM Standards:

- C 43 Terminology of Structural Clay Products²
- C 67 Test Methods of Sampling and Testing Brick and Structural Clay Tile²
- C 140 Test Methods of Sampling and Testing Concrete Masonry Units²
- E 577 Guide for Dimensional Coordination of Rectilinear

- Building Parts and Systems³
- E 631 Terminology of Building Constructions³

3. Terminology

3.1 Definitions of Terms Specific to This Standard:

3.1.1 For descriptions of terms not listed in 3.1.2-3.1.12 see Terminology C 43, the Terminology section of Guide E 577, or Terminology E 631.

3.1.2 *coordinating dimension*—a preferred modular dimension for masonry or masonry openings coordination, including allowances for standard joint thicknesses. (For example, vertical coordination based on masonry units with three courses equal to 200 mm or 8 in.) See Fig. 1.

3.1.3 *grid line*—a line of the modular (100 mm or 4 in.) grid, used for referencing of building dimensions in design and construction, normally occurring as centerlines in modular coursing and as coordinating lines for masonry and masonry openings.

3.1.4 *height*—vertical dimension of masonry units or masonry, measured parallel to the intended face of the unit or units. See Fig. 2.

3.1.5 *length*—horizontal dimension of masonry units or masonry, measured parallel to the intended face of the unit or units. See Fig. 2.

3.1.6 *nominal dimension*—a dimension greater than the specified (standard) dimension by the thickness of one mortar joint, but not more than 13 mm or 1/2 in.

3.1.6.1 *Discussion*—Standard mortar joint thicknesses are 6 mm (1/4 in.), 10 mm (3/8 in.), and 13 mm (1/2 in.).

¹ This guide is under the jurisdiction of ASTM Committee E-6 on Performance of Buildings and is the direct responsibility of Subcommittee E06.62 on Coordination of Dimensions for Building Materials and Systems.

Current edition approved Feb. 15, 1993. Published July 1993. Originally published as E 835M – 81. Last previous edition E 835/E 835M – 88.

² *Annual Book of ASTM Standards*, Vol 04.05.

³ *Annual Book of ASTM Standards*, Vol 04.07.

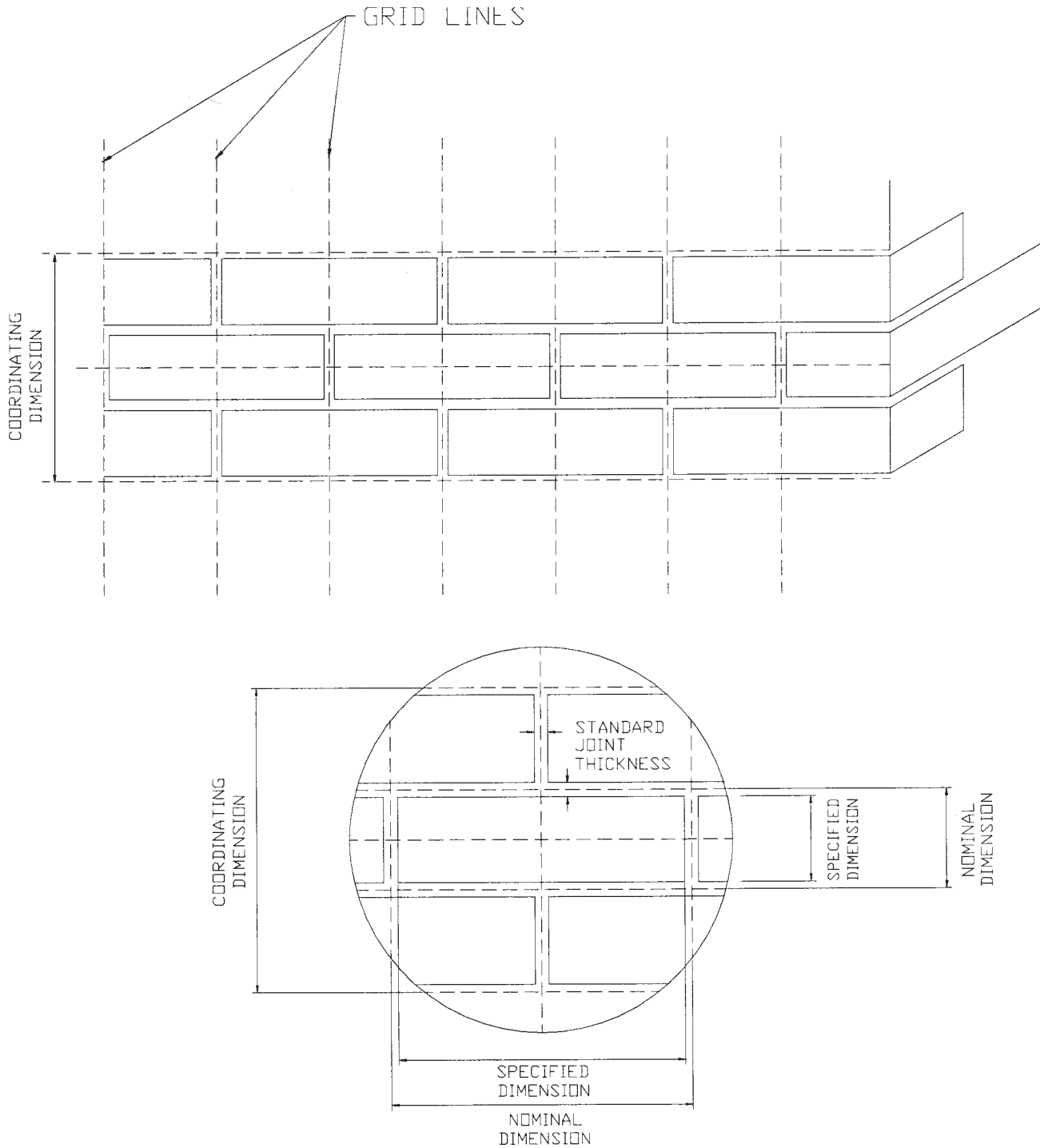

FIG. 1 Coordinating, Nominal, and Specified (Standard) Dimensions for Masonry Units

3.1.7 *nominal size*—the measure of layout of a single masonry unit, taken between centerlines of mortar joints, which is equal to the specified unit size plus the thickness of one mortar joint. See Fig. 1.

3.1.8 *specified (standard) dimension*—the nominal dimension less the thickness of a standard mortar joint; that is, the net dimension of the masonry unit. See Fig. 1.

3.1.9 *specified size*—the average of measured dimensions of the masonry units determined in accordance with Test Methods C 67 or Method C 140, excluding standard joint thickness.

3.1.10 *supplementary unit*—an additional masonry unit used to provide modular (100 mm or 4 in.) flexibility.

3.1.11 *thickness (width)*—horizontal dimension of masonry units or masonry measured perpendicular to the intended face of the masonry unit or units. See Fig. 2.

3.1.11.1 *Discussion*—The term *thickness* is used with clay products as the dimension perpendicular to the face of the wall. The term *width* is used with concrete masonry units as the dimension perpendicular to the face of the wall.

3.1.12 *width*—see *thickness*.

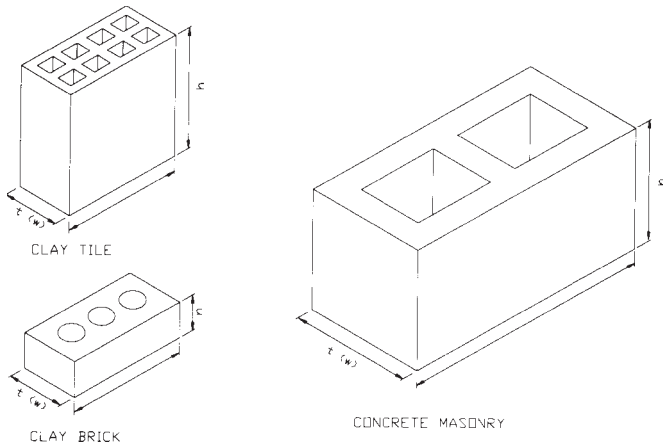

NOTE 1—Specified dimensions indicated
FIG. 2 Nomenclature for Unit Dimensions

4. Standardization of Sizes

4.1 *Masonry Units:*

4.1.1 *Nominal Size*—Nominal size is reported as thickness (t) or width (w) by height (h) by length (l).

4.1.2 *Full Size Units*—The nominal and coordinating dimensions of full-size modular masonry units shall be as indicated in Table 1 and Table 2.

4.1.3 *Supplementary-Size Units*—Supplementary-size units may be needed in conjunction with full-size units to provide modular (100 mm or 4 in.) flexibility for walls, suitable bond patterns, or both. Nominal sizes for supplementary units required to maintain one-third and one-quarter running bond are provided in Tables 1 and 2. Supplementary sizes required for use in a particular project may be cut on the job-site or furnished by the manufacturer.

NOTE 1—The need for finished faces at areas exposed to weather or view should be taken into consideration when specifying supplementary units.

5. Keywords

5.1 dimensional coordination; masonry; modular coordination

TABLE 1 Coordinating Dimensions for Masonry Units Dimensions in Millimetres

Nominal Size			Number of Courses per Coordinating Height	Running Bond Pattern	Supplementary Units (nominal size)		
$t(w)$	h	l			$t(w)$	h	l
100	50	200	2:100	1/2
100	50	300	2:100	1/3	100	50	200
100	50	400	2:100	1/4	100	50	300
100	67	200	3:200	1/2
100	67	300	3:200	1/3	100	67	200
100	67	400	3:200	1/4	100	67	300
100	80	200	5:400	1/2
100	80	300	5:400	1/3	100	80	200
100	80	400	5:400	1/4	100	80	300
100	100	200	1:100	1/2
100	100	300	1:100	1/3	100	100	200
100	100	400	1:100	1/4	100	100	300
100	200	200	1:200	1/2
100	200	300	1:200	1/2
100	200	400	1:200	1/4	100	200	300
150	100	400	1:100	3/8	150	100	350
150	200	400	1:200	3/8	150	200	350
200	100	400	1:100	1/2
200	200	400	1:200	1/2
250	100	400	1:100	3/8	250	100	350
250	200	400	1:200	3/8	250	200	350
300	100	400	1:100	1/4	100	100	300
300	200	400	1:200	1/4	100	200	300

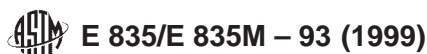

TABLE 2 Coordinating Dimensions for Masonry Units Dimensions in Inches

Nominal Size Unit			Number of Courses per Coordinating Height	Running Bond Pattern	Supplementary Units (nominal size)		
t(w)	h	l			t(w)	h	l
4	2	8	2:4	1/2
4	2	12	2:4	1/3	4	2	8
4	2	16	2:4	1/4	4	2	12
4	2 2/3	8	3:8	1/2
4	2 2/3	12	3:8	1/3	2	2 2/3	8
4	2 2/3	16	3:8	1/4	2	2 2/3	12
4	3 1/5	8	5:16	1/2
4	3 1/5	12	5:16	1/3	4	3 1/5	8
4	3 1/5	16	5:16	1/4	4	3 1/5	12
4	4	8	1:4	1/2
4	4	12	1:4	1/3	4	4	8
4	4	16	1:4	1/4	4	4	12
4	8	8	1:8	1/2
4	8	16	1:8	1/4	4	8	12
6	4	16	1:4	3/8	6	4	14
6	8	16	1:8	3/8	6	8	14
8	4	16	1:4	1/2
8	8	16	1:8	1/2
10	4	16	1:4	3/8	10	4	14
10	8	16	1:8	3/8	10	8	14
12	4	16	1:4	1/4	4	4	12
12	8	16	1:8	1/4	4	8	12

ASTM International takes no position respecting the validity of any patent rights asserted in connection with any item mentioned in this standard. Users of this standard are expressly advised that determination of the validity of any such patent rights, and the risk of infringement of such rights, are entirely their own responsibility.

This standard is subject to revision at any time by the responsible technical committee and must be reviewed every five years and if not revised, either reapproved or withdrawn. Your comments are invited either for revision of this standard or for additional standards and should be addressed to ASTM International Headquarters. Your comments will receive careful consideration at a meeting of the responsible technical committee, which you may attend. If you feel that your comments have not received a fair hearing you should make your views known to the ASTM Committee on Standards, at the address shown below.

This standard is copyrighted by ASTM International, 100 Barr Harbor Drive, PO Box C700, West Conshohocken, PA 19428-2959, United States. Individual reprints (single or multiple copies) of this standard may be obtained by contacting ASTM at the above address or at 610-832-9585 (phone), 610-832-9555 (fax), or service@astm.org (e-mail); or through the ASTM website (www.astm.org).