



# Standard Practice for Roof System Assemblies Employing Steel Deck, Preformed Roof Insulation, and Bituminous Built-Up Roofing<sup>1</sup>

This standard is issued under the fixed designation E 936; the number immediately following the designation indicates the year of original adoption or, in the case of revision, the year of last revision. A number in parentheses indicates the year of last reapproval. A superscript epsilon ( $\epsilon$ ) indicates an editorial change since the last revision or reapproval.

## 1. Scope

1.1 This practice covers the performance requirements for the design, components, construction, and service expectations of new roof system assemblies. For this purpose, the roof system always includes steel deck, preformed roof insulation, and bituminous built-up roofing, and their attachment. It may also include fire-resistive components, integral acoustical treatment, vapor retarder, adhesive or mechanical fastener attachment, and aggregates.

1.2 The objective is to provide realistic criteria for the overall performance of the roof assembly and its components because by necessity and custom, a roof assembly contains a variety of components and is subject to varied environmental conditions.

1.3 To assist in the successful implementation of the installation and service requirements of the roof system assembly, criteria are established to provide for compatibility of the various components.

1.4 Nothing in this practice is intended to exclude products or systems not covered by the documents referenced in Section 2.

1.5 *This standard does not purport to address all of the safety concerns, if any, associated with its use. It is the responsibility of the user of this standard to establish appropriate safety and health practices and determine the applicability of regulatory limitations prior to use.*

1.6 The values stated in either SI units or inch-pound units are to be regarded separately as standard. The values stated in each system are not exact equivalents; therefore, each system must be used independently of the other.

## 2. Referenced Documents

### 2.1 ASTM Standards:

A 529/A 529M Specification for High-Strength Carbon-Manganese Steel of Structural Quality<sup>2</sup>

A 570/A 570M Specification for Structural Steel, Sheet and

Strip, Carbon, Hot-Rolled<sup>3</sup>

A 606 Specification for Steel, Sheet and Strip, High-Strength, Low-Alloy, Hot-Rolled and Cold-Rolled, with Improved Atmospheric Corrosion Resistance<sup>3</sup>

A 607 Specification for Steel, Sheet and Strip, High-Strength, Low-Alloy Columbium or Vanadium, or Both, Hot-Rolled and Cold-Rolled<sup>3</sup>

A 611 Specification for Structural Steel, Sheet, Carbon, Cold-Rolled<sup>3</sup>

A 653/A 653M Standard Specification for Steel Sheet, Zinc-Coated (Galvanized) or Zinc-Iron Alloy-Coated (Galvannealed) by the Hot-Dip Process<sup>4</sup>

B 117 Practice for Operating Salt Spray (Fog) Apparatus<sup>5</sup>

C 177 Test Method for Steady-State Heat Flux Measurements and Thermal Transmission Properties by Means of the Guarded-Hot-Plate Apparatus<sup>6</sup>

C 208 Specification for Cellulosic Fiber Insulating Board<sup>6</sup>

C 209 Test Methods for Cellulosic Fiber Insulating Board<sup>6</sup>

C 236 Test Method for Steady-State Thermal Performance of Building Assemblies by Means of a Guarded Hot Box<sup>6</sup>

C 518 Test Method for Steady-State Heat Flux Measurements and Thermal Transmission Properties by Means of the Heat Flow Meter Apparatus<sup>6</sup>

C 550 Practice for Measuring Trueness and Squareness of Rigid Block Thermal Insulation<sup>6</sup>

C 552 Specification for Cellular Glass Thermal Insulation<sup>6</sup>

C 578 Specification for Rigid, Cellular Polystyrene Thermal Insulation<sup>6</sup>

C 726 Specification for Mineral Fiber Roof Insulation Board<sup>6</sup>

C 728 Specification for Perlite Thermal Insulation Board<sup>6</sup>

C 755 Practice for Selection of Vapor Retarders for Thermal Insulation<sup>6</sup>

C 1126 Specification for Faced or Unfaced Rigid Cellular Phenolic Thermal Insulation<sup>6</sup>

C 1289 Specification for Faced Rigid Cellular Polyisocyanurate Thermal Insulation Board<sup>6</sup>

D 41 Specification for Asphalt Primer Used in Roofing,

<sup>1</sup> This practice is under the jurisdiction of ASTM Committee E-6 on Performance of Buildings and is the direct responsibility of Subcommittee E06.21 on Serviceability.

Current edition approved Dec. 10, 1998. Published March 1999. Originally published as E 936 – 83. Last previous edition E 936 – 97.

<sup>2</sup> *Annual Book of ASTM Standards*, Vol 01.04.

<sup>3</sup> *Annual Book of ASTM Standards*, Vol 01.03.

<sup>4</sup> *Annual Book of ASTM Standards*, Vol 01.06.

<sup>5</sup> *Annual Book of ASTM Standards*, Vol 03.02.

<sup>6</sup> *Annual Book of ASTM Standards*, Vol 04.06.

- Dampproofing, and Waterproofing<sup>7</sup>
- D 146 Test Methods for Sampling and Testing Bitumen-Saturated Felts and Woven Fabrics for Roofing and Waterproofing<sup>7</sup>
- D 226 Specification for Asphalt-Saturated Organic Felt Used in Roofing and Waterproofing<sup>7</sup>
- D 227 Specification for Coal-Tar-Saturated Organic Felt Used in Roofing and Waterproofing<sup>7</sup>
- D 244 Test Methods for Emulsified Asphalts<sup>8</sup>
- D 249 Specification for Asphalt Roll Roofing (Organic Felt) Surfaced with Mineral Granules<sup>7</sup>
- D 312 Specification for Asphalt Used in Roofing<sup>7</sup>
- D 371 Specification for Asphalt Roll Roofing (Organic Felt) Surfaced with Mineral Granules; Wide Selvage<sup>7</sup>
- D 450 Specification for Coal-Tar Pitch Used in Roofing, Dampproofing, and Waterproofing<sup>7</sup>
- D 1079 Terminology Relating to Roofing, Waterproofing, and Bituminous Materials<sup>7</sup>
- D 1227 Specification for Emulsified Asphalt Used as a Protective Coating for Roofing<sup>7</sup>
- D 1310 Test Method for Flash Point and Fire Point of Liquids by Tag Open-Cup Apparatus<sup>9</sup>
- D 1863 Specification for Mineral Aggregate Used on Built-Up Roofs<sup>7</sup>
- D 2178 Specification for Asphalt Glass Felt Used in Roofing and Waterproofing<sup>7</sup>
- D 2626 Specification for Asphalt-Saturated and Coated Organic Felt Base Sheet Used in Roofing<sup>7</sup>
- D 2822 Specification for Asphalt Roof Cement<sup>7</sup>
- D 2823 Specification for Asphalt Roof Coatings<sup>7</sup>
- D 2824 Specification for Aluminum-Pigmented Asphalt Roof Coatings, Non-Fibered Asbestos Fibered and Fibered Without Asbestos<sup>7</sup>
- D 2829 Practice for Sampling and Analysis of Built-Up Roofs<sup>7</sup>
- D 3617 Practice for Sampling and Analysis of New Built-Up Roof Membranes<sup>7</sup>
- D 3909 Specification for Asphalt Roll Roofing (Glass Felt) Surfaced With Mineral Granules<sup>7</sup>
- D 4077 Specification for Coal Tar Roof Cement, Asbestos Containing<sup>7</sup>
- D 4479 Specification for Asphalt Roof Coatings, Asbestos-Free<sup>7</sup>
- D 4586 Specification for Asphalt Roof Cement, Asbestos-Free<sup>7</sup>
- D 4601 Specification for Asphalt-Coated Glass Fiber Base Sheet Used in Roofing<sup>7</sup>
- D 4897 Specification for Asphalt-Coated Glass-Fiber Venting Base Sheet Used in Roofing<sup>7</sup>
- D 4990 Specification for Coal Tar Glass Felt Used in Roofing and Waterproofing<sup>7</sup>
- E 84 Test Method for Surface Burning Characteristics of Building Materials<sup>10</sup>

- E 96 Test Methods for Water Vapor Transmission of Materials<sup>6</sup>
- E 108 Test Methods for Fire Tests of Roof Coverings<sup>10</sup>
- E 119 Test Methods for Fire Tests of Building Construction and Materials<sup>10</sup>
- E 196 Practice for Gravity Load Testing of Floors and Flat Roofs<sup>11</sup>
- E 241 Practices for Increasing Durability of Building Constructions Against Water-Induced Damage<sup>11</sup>
- E 541 Criteria for Agencies Engaged in System Analysis and Compliance Assurance for Manufactured Building<sup>12</sup>
- E 631 Terminology of Building Constructions<sup>11</sup>
- E 651 Guidelines for Evaluating Capabilities of Agencies Involved in System Analysis and Compliance Assurance for Manufactured Building<sup>12</sup>
- E 699 Practice for Criteria for Evaluation of Agencies Involved in Testing, Quality Assurance, and Evaluating Building Components in Accordance with Test Methods Promulgated By ASTM Committee E-6<sup>12</sup>
- E 907 Test Method for Field Testing Uplift Resistance of Adhered Membrane Roofing Systems<sup>11</sup>

2.2 *Factory Mutual Research Corporation (FM) Documents:*<sup>13</sup>

- FM Approval Guide  
Approval Standard 4450  
Class I Steel Deck Roofs  
Approval Standard 4451 for Steel Deck Nominal 1½in. Deep As Component of Class I Insulated Steel Roof Deck Construction  
Approval Standard 4470 Class I Roof Covers  
FM 1-28 Loss Prevention Data Insulated Steel Deck  
FM-1-48 Loss Prevention Data SH Repair Procedures for Built-Up Roof Coverings Over Steel Decks  
FM-1-49 Loss Prevention Data SH Perimeter Flashing  
FM-1-52 Loss Prevention Data Wind Uplift

2.3 *Underwriters' Laboratories, Inc. (UL) Documents:*<sup>14</sup>

- Roofing Materials and Systems Directory  
Publication No. 1256—Outline of the Proposed Investigation for Roof Deck Construction  
U.L. 580 Standard for Safety, Tests for Wind Uplift Resistance of Roof Assemblies  
Fire Resistance Directory

2.4 *National Roofing Contractors Association (NRCA) Document:*<sup>15</sup>

- NRCA Energy Manual  
Bulletin 2-91  
Equiviscous Temperature (EVT)  
NRCA/ARMA Manual of Roof Maintenance and Repair  
ARMA/NRCA Quality Control Guidelines for the Application of Built-Up Roofing

<sup>7</sup> *Annual Book of ASTM Standards*, Vol 04.04.

<sup>8</sup> *Annual Book of ASTM Standards*, Vol 04.03.

<sup>9</sup> *Annual Book of ASTM Standards*, Vol 06.01.

<sup>10</sup> *Annual Book of ASTM Standards*, Vol 04.07.

<sup>11</sup> *Annual Book of ASTM Standards*, Vol 04.11.

<sup>12</sup> *Annual Book of ASTM Standards*, Vol 14.02.

<sup>13</sup> Available from Factory Mutual Research Corporation, P.O. Box 688, Norwood, MA 02062.

<sup>14</sup> Available from Underwriters' Laboratories, Inc., 333 Pfingsten Rd., Northbrook, IL 60062.

<sup>15</sup> Available from National Roofing Contractors Assoc., 10255 West Higgins Road, Suite 600, Rosemont, IL 60018-5607.

Roofing and Waterproofing Manual, 1989  
 In Service R-Values (ISR) for Polyisocyanurate and Polyurethane Roof Insulation Boards

2.5 *Steel Deck Institute (SDI) Document:*<sup>16</sup>

Steel Deck Institute Design Manual

2.6 *American Iron and Steel Institute (AISI) Standards:*  
 Specification for the Design of Cold Formed Steel Structural Members, August 19, 1986 Edition<sup>17</sup>

2.7 *American Institute of Architects (AIA):*  
 Roof System Design Manual<sup>18</sup>

2.8 *Canadian Roofing Contractors Association (CRCA):*  
 Roofing Manual<sup>19</sup>

2.9 *American Society of Heating, Refrigerating and Air-Conditioning Engineers (ASHRAE):*  
 Roofing Insulation Recommendations<sup>20</sup>

2.10 *Sheet Metal and Air Conditioning Contractors National Association Standard:*

Architectural Sheet Metal Manual, SMACMA<sup>21</sup>

2.11 *The Aluminum Association Incorporated Standard:*  
 Specification for Aluminum Sheet Metal Work in Building Construction<sup>22</sup>

2.12 *Copper Development Association, Inc. Documents:*<sup>23</sup>

Architectural Applications 405/7R

Base and Cap Flashings 402/9

Sheet Copper Fundamentals 406/9

Building Expansion Joints 408/70

2.13 *American Welding Society (AWS) Standard:*

AWS D1.3-81, Specification for Welding Sheet Steel in Structures<sup>24</sup>

2.14 *National Institute of Standards and Technology Publications:*<sup>25</sup>

Building Science Series No. 9—Thermal Shock Resistance for Built-up Membranes

Building Science Series No. 55—Preliminary Performance Criteria for Bituminous Membrane Roofing

Building Science Series No. 92—Viscosities of Roofing Asphalts at Application Temperatures

Technical Note 473—Laboratory Field Comparisons of Built-up Roofing Membranes

2.15 *Midwest Roofing Contractors Association Document:*

Ten Years of Roofing Research<sup>26</sup>

### 3. Terminology

3.1 *Definitions*—Refer to Terminology D 1079 and Terminology E 631.

### 4. Performance Concepts

4.1 *Design*—The roof system should be designed in accordance with this practice to resist the effects of the usual or normal weather and loading conditions which can cause excessive deflection, destroy adhesive bond, fracture the insulation, and result in premature failure of the roof system. Such weather and loading conditions may include, but are not confined to water, wind, hail, snow, ice, and uniform and concentrated loading, and thermal expansion and contraction of building units. The roof system should be sloped to provide drainage under design loading conditions and the design should sustain the anticipated live load if drainage is obstructed (see section 16.4).

4.2 *Construction*—During construction, the partially completed and the completed roof assembly should (1) be protected against construction traffic and equipment to be used in the construction of the roof assembly and subsequent traffic and use by other trades and (2) provide weather protection consistent with the construction schedule requirements as determined by the existing weather conditions.

4.3 *Service*—The roof system assembly when in service should:

4.3.1 Be protected against anticipated building maintenance procedures.

4.3.2 Provide weather protection.

4.3.3 Provide thermal insulation.

4.3.4 Provide a vapor retarder, if required.

4.3.5 Provide fire safety and uplift resistance as required by the building owner, applicable building codes, or insurance underwriters.

4.3.6 Carry anticipated design dead loads and live loads.

4.3.7 Receive proper and periodic maintenance over its service life.

4.4 The components used in the roof system assembly should be compatible with each other.

### 5. Design, Materials, and Construction Requirements

5.1 All components of the roof system should conform to specific design criteria essential to provide an assembly capable of fulfilling the performance concepts.

NOTE 1—The spacing, and straightness, stiffness, and strength of the steel deck supports are important to proper deck installation and should be confirmed by the designer or their representative.

NOTE 2—For locations other than roof edge and nonwall supported details, the need for wood nailers should be determined by the designer or specifier.

NOTE 3—The first layer of the preformed insulation can be more positively secured by mechanical fasteners with the additional layers of preformed insulation fully adhered to the first layer.

<sup>16</sup> Available from Steel Deck Institute, P.O. Box 9506, Canton, OH 44711.

<sup>17</sup> Available from American Iron and Steel Institute, 1101 17th St., N.W., Suite 1300, Washington, DC 20036-4700.

<sup>18</sup> Available from American Institute of Architects, 1735 New York Ave., NW, Washington, DC 20006.

<sup>19</sup> Available from Canadian Roofing Contractors Assn., 116 Albert St., Ste 710, Ottawa, Ontario Canada K1P 5G3.

<sup>20</sup> Available from American Society of Heating, Refrigerating and Air Conditioning Engineers, 1791 Tullie Circle NE, Atlanta, GA 30329.

<sup>21</sup> Available from Sheet Metal and Air Conditioning Contractors' National Assn., 4201 Lafayette Center Drive, Chantilly, VA 22021.

<sup>22</sup> Available from The Aluminum Association, 818 Connecticut Ave. NW, Washington, DC 20006.

<sup>23</sup> Available from Copper Development Assn., Inc., 405 Lexington Ave., New York, NY 10174.

<sup>24</sup> Available from American Welding Society, 550 LaJeune, Coral Gables, FL 33134.

<sup>25</sup> Available from National Institute of Standards and Technology, Gaithersburg, MD 20899.

<sup>26</sup> Available from Midwest Roofing Contractors Assn., Suite 1000, Lawrence, KS 66049-3855.

5.2 The design should be in accordance with the owner’s insurance carrier’s requirements, when applicable.

5.3 The performance of all roof-system components and the roof system itself should be confirmed by test procedures. These procedures shall be those established by recognized agencies including, but not confined to, independent testing agencies acceptable to the authority having jurisdiction.

5.3.1 Performance of individual components of the roof system evaluated by on-site testing is covered under materials guidelines in Sections 6-12 inclusive.

5.4 Construction materials should be protected after manufacture, while in transit or storage, and at the job site.

5.4.1 Damaged materials should not be installed.

5.5 A pre-roofing conference should be conducted prior to the erection or assembly of the roof system (Appendix X2.9).

## REQUIREMENTS FOR COMPONENTS

### 6. Steel Roof Deck

6.1 *Design Guidelines*—The steel deck should be designed in accordance with the following provisions:

NOTE 4—Load tables based on uniformly distributed loads are not the sole determinant of deck section because concentrated loads (in excess of 1.3 kN (300 lb)) common to construction practice, may control span lengths.

6.1.1 *Section Properties*—The Section Modulus and Moment of Inertia should be computed in accordance with AISI Specification for the Design of Cold-Formed Steel Structural Members.

6.1.2 *Yield Strength*—The minimum yield strength of the steel,  $f_y$ , should be 228 MPa (33 000 psi). The unit design stress or working stress,  $f_d$ , or both, should not exceed 250 MPa

(36 000 psi) or the minimum yield strength of the steel multiplied by 0.60, whichever is the lesser, [that is,  $f_d \leq 0.60 f_y$  not to exceed 250 MPa (36 000 psi)].

NOTE 5—**Caution:** The hardness of the steel deck should be considered when selecting the insulation fasteners.

6.1.3 *Allowable-Span Determinations*— The maximum allowable span for the steel deck should be the least of three computational determinations for span predicated on deflection and stress limitations under specific concentrated and uniform loading conditions as follows:

6.1.3.1 *Span based on concentrated loading deflection:* When subjected to a minimum 1.3 kN (300-lb) concentrated load representing construction loading, located at midspan of a single-span deck, or at midspan of an end span where the deck is continuous over two or more spans, the maximum allowable deck span should not exceed 240 times the deflection resulting from concentrated load. Span should be computed as shown in Fig. 1.

6.1.3.2 *Maximum deck span based on deflection due to design uniform live load* should not exceed 240 times the deflection. Span may be computed as shown in Fig. 2.

6.1.3.3 *Maximum deck span based on stress due to design uniform total load (dead plus live)* may be computed as shown in Fig. 3.

6.1.4 *Side Lap*—Side laps of individual sheets should be fastened together between supports so as to limit differential deflection of adjacent sheets between fasteners to 6 mm (1/4 in.) or less when subjected to a 1.3 kN (300 lb) concentrated load. In no case shall the spacing of side-lap fastening between supports exceed 1 m (36 in.) (see 6.3.5.2).

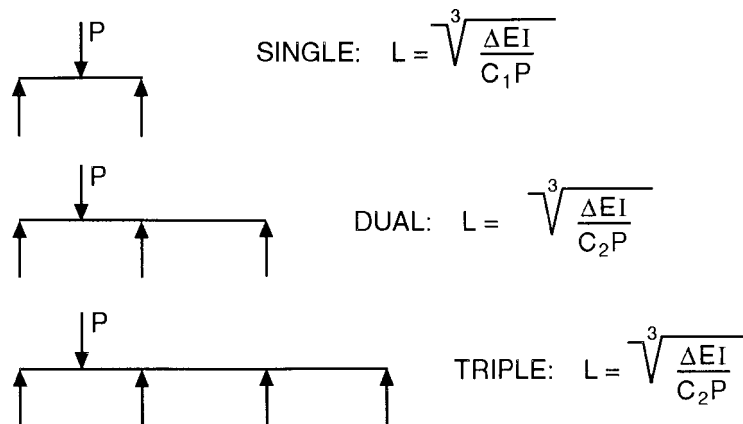

- P = Concentrated load, newtons/m width (pounds/ft width). Concentrated load = line load normal to the span. Use 2.9 kN/m width (200 lbf/ft width) minimum.
- L = Span, millimeters (inches), center to center of supports (end or intermediate), applicable to equal spans only. For unequal spans, other formulas are available.
- I = Moment of inertia of steel deck, m<sup>4</sup>/m width (in.<sup>4</sup>/ft width).
- E = Modulus of Elasticity of steel = 2.0 × 10<sup>5</sup> MPa (29.5 × 10<sup>6</sup> psi) Note—1 MPa = 10<sup>6</sup> N/m<sup>2</sup> and use of MPa value compensates for dimensional adjustments in formulas.
- Δ = Deflection, millimeters (inches) usually limited to L/240.
- C<sub>1</sub> = 0.021 for SI and inch pound unit dimensions.
- C<sub>2</sub> = 0.015 for SI and inch pound unit dimensions.

NOTE 1—Independent tests have indicated that a concentrated load applied over a width less than or equal to 0.3 m (1 ft) and some nominal length will be distributed over or resisted by a 0.45 m (1.5 ft) width of deck when side laps are properly fastened and when sheets are greater than 0.3 m (1 ft) wide. This justifies using 2.9 kN/m width (200 lbf/ft width) to approximate an actual concentrated load of 1.3 kN (300 lbf).

**FIG. 1 Span Based on Concentrated Loading Deflection**



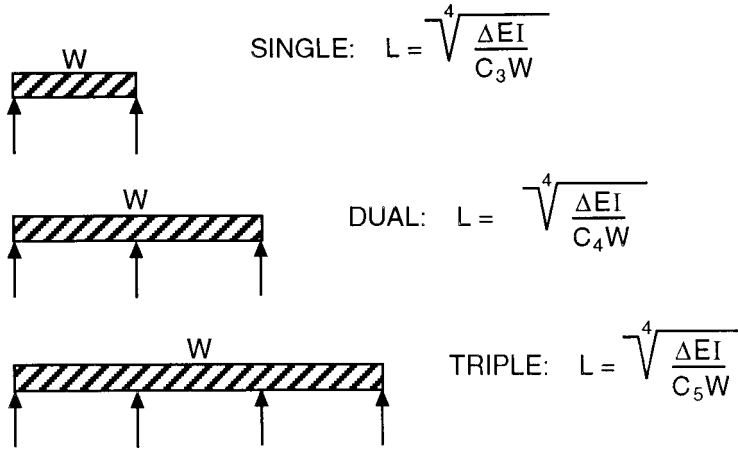

- W = Uniform Live Load, newtons/mm length, across a 1 meter wide section (pounds/inch length, across a 1 foot wide section).
- L = Span, millimeters (inches), center to center of supports (end or intermediate), applicable to equal spans only. For unequal spans, other formulas are available.
- I = Moment of inertia of steel deck, mm<sup>4</sup>/m width (in.<sup>4</sup>/foot width). Note: This choice of units is dimensionally and conceptually consistent with "W".
- E = Modulus of Elasticity of steel = 2.0 × 10<sup>5</sup> MPa (29.5 × 10<sup>6</sup> psi) Note—1 MPa = 10<sup>6</sup> N/m<sup>2</sup> and use of MPa value compensates for dimensional adjustments in formulas.
- Δ = Deflection, millimeters (inches) usually limited to L/240.
- C<sub>3</sub> = 0.0130 for SI and inch pound unit dimensions.
- C<sub>4</sub> = 0.0054 for SI and inch pound unit dimensions.
- C<sub>5</sub> = 0.0069 for SI and inch pound unit dimensions.

NOTE 1—This Choice of units is unusual but makes the formulas dimensionally admissible as presented—e.g. W = Newtons/mm\*m and lbf/in.\*ft.

FIG. 2 Span Based on Uniform Live Load Deflection

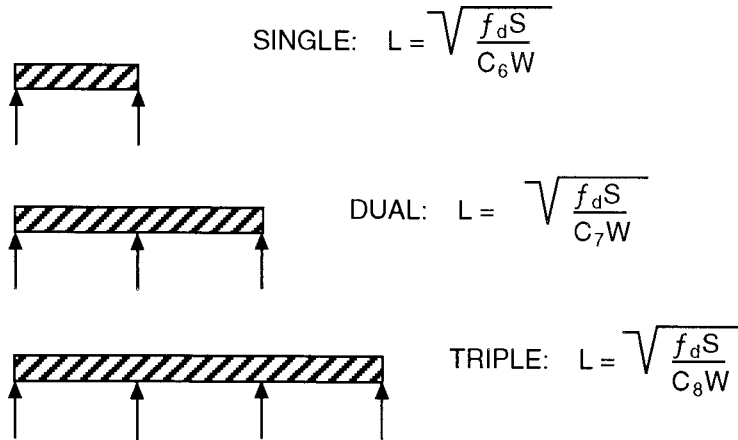

- W = Uniform Load, newtons/mm length, across a 1 meter wide section (pounds/inch length across a 1 foot wide section).
- L = Span, millimeters (inches), center to center of supports (end or intermediate), applicable to equal spans only. For unequal spans, other formulas are available.
- f<sub>d</sub> = Maximum allowable design stress for grade of steel being employed, megapascals (pounds per square inch). Note: 1 MPa = 10<sup>6</sup> N/m<sup>2</sup> and the use of the MPa value provides the required dimensional adjustment in formulas.
- S = Section Modulus of steel deck, mm<sup>3</sup>/m width (in.<sup>3</sup>/ft width). Note: This choice of units is dimensionally and conceptually consistent with "W".
- C<sub>6</sub> = 0.125 for SI and inch pound unit dimensions and applies at midspan.
- C<sub>7</sub> = 0.125 for SI and inch pound unit dimensions and applies at interior supports. .07 is used when stress is being evaluated at midspan—rarely critical for relatively symmetric profiles.
- C<sub>8</sub> = 0.100 for SI and inch pound unit dimensions and applies at interior supports. .08 is used when stress is being evaluated at midspan.

NOTE 1—The above choice of units is unusual but makes the formulas dimensionally admissible as presented—e.g. W = Newtons/mm\*m and lbf/in.\*ft.

NOTE 2— For derivation of f<sub>d</sub> see 6.1.2.

NOTE 3—The Section Modulus (S) for single span shall be based on the positive Section Modulus (S<sub>p</sub>) when the load causes positive bending. The Section Modulus (S) selection for dual, triple, and other multiple spans shall consider both the negative (S<sub>n</sub>) and positive (S<sub>p</sub>) Section Moduli as published by the appropriate steel deck manufacturer. The selection of Section Modulus and moment coefficient shall be consistent with the span location and bending type—e.g. midspan and positive bending on a four equal span application, use 0.08 and S<sub>p</sub>.

FIG. 3 Span Based on Stress Due to Uniform Total Load

6.1.5 Anchorage—At perimeters of roof areas, the deck should be supported to prevent differential deflection. Steel deck units should be anchored to the supporting framework by

deck fasteners or welding. All deficient welds or mechanical fasteners should be replaced before installing other components. Steel deck and anchorage should resist the gross uplift

force due to the anticipated wind velocity and internal building pressure on the roof being considered. The dead load of the roof-deck construction should be deducted from the above uplift forces.

6.1.6 *Design Thickness,  $t_d$* —Deck manufacturers’ published load tables, section properties, and maximum span should be based on decimal thickness. The uncoated minimum steel thickness of the cold-formed product as delivered to the job site shall not at any location be less than 95 % of the thickness used in its design, however thicknesses may be less at bends such as corners due to cold forming effects. The uncoated thickness for listed design thicknesses are shown in Table 1.

6.1.6.1 Decks may be manufactured to any decimal thickness in excess of 0.70 mm (0.028 in.), providing the thickness is no less than 95 % of the design thickness ( $0.95 t_d$ ).

6.1.7 *Steel Roof-Deck Shape*—The configurations of steel roof decks vary among manufacturers, but the top surfaces should conform to the limitations in 6.2.3, top-flange surface. The top flange should provide a flat contact surface of no less than 50 % of the roof area.

6.1.7.1 *Narrow Rib Deck*—A deck whose rib opening, measured along the top surface at the theoretical intersection points of the flange and web projections, is 25 mm (1 in.) or less (see Fig. 4).

6.1.7.2 *Intermediate Rib Deck*—A deck whose rib opening, measured along the top surface at the theoretical intersection points of the flange and web projections, is greater than 25 mm (1 in.) up to and including 44 mm ( $1\frac{3}{4}$  in.) (see Fig. 5).

6.1.7.3 *Wide Rib Deck*—A deck whose rib opening, measured along the top surface at the theoretical intersection points of the flange and web projections, is greater than 44 mm ( $1\frac{3}{4}$  in.) up to and including 67 mm ( $2\frac{5}{8}$  in.) (see Fig. 6).

6.1.7.4 *Open Rib Deck*—A deck whose rib opening, measured along the top surface at the theoretical intersection points of the flange and web projections, is greater than 67 mm ( $2\frac{5}{8}$  in.) and up to and including 92 mm ( $3\frac{5}{8}$  in.) maximum (see Fig. 7). This deck section should have a rib spacing of 200 mm (8 in.) or more.

6.1.8 *Steel Roof-Deck Diaphragm Design*— The deck may be designed to function as a diaphragm and sustain shear imposed by windstorm or seismic forces. Such construction may necessitate additional fastening determined in a specific manner and is the responsibility of the designer.

6.1.9 All deck openings that exceed 300 by 300 mm (12 by 12 in.) should be reinforced.

6.1.10 At changes in deck direction or plane, such as at ridges, valleys, and hips, a sheet-steel closure plate not less than 0.6 mm thick by 200 mm wide (0.024 in. thick by 8 in. wide), bent to conform to the deck planes, should be provided.

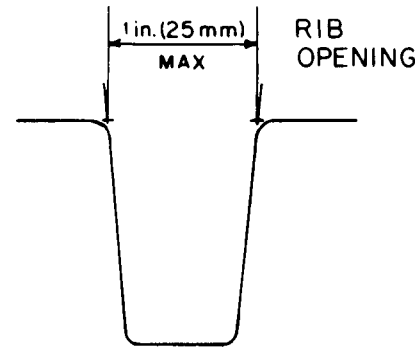

FIG. 4 Narrow Rib Deck

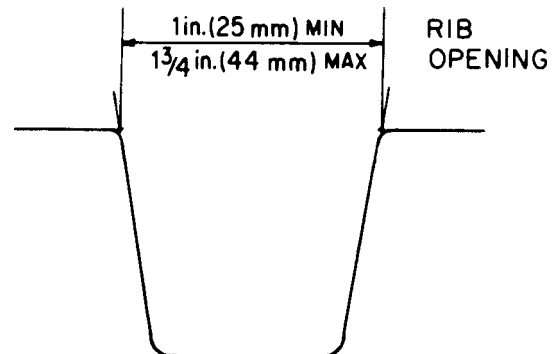

FIG. 5 Intermediate Rib Deck

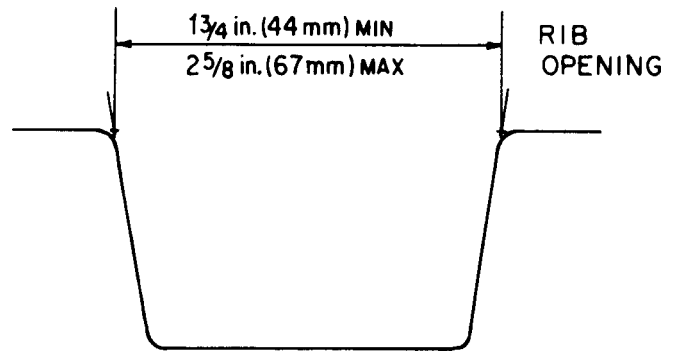

FIG. 6 Wide Rib Deck

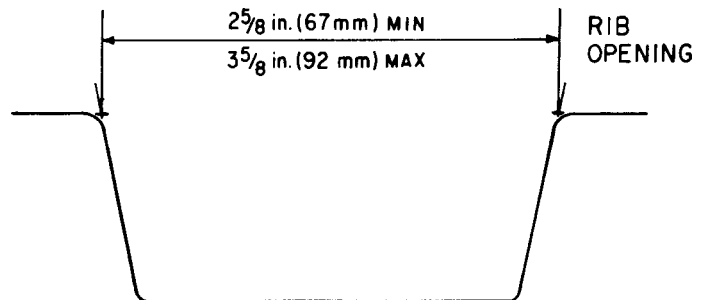

FIG. 7 Open Rib Deck

TABLE 1 Uncoated Thickness for Listed Design Thicknesses of Steel

Design Thickness, $t_d$ , mm (in.)	Minimum Accepted Thickness, Uncoated, $0.95t_d$ , mm (in.)
0.749 (0.0295)	0.71 (0.028)
0.909 (0.0358)	0.86 (0.034)
1.204 (0.0474)	1.14 (0.045)
1.519 (0.0598)	1.44 (0.057)

These are fastened, preferably with sheet metal screws spaced not more than 300 mm (12 in.) to both sides of the deck joints.

6.1.11 At changes in deck structural systems, discontinuous diaphragm construction, and where structural movement is to be accommodated in the framing, an expansion joint should be provided in the roofing system.

6.2 *Materials Guidelines*—The deck should conform to the following requirements:

6.2.1 *Identification*—Each deck bundle should be tagged showing design thickness and manufacturer’s name.

6.2.2 *Manufactured Tolerances*—The depth of the steel deck, as manufactured, should be within a tolerance of  $\pm 1.1$  mm ( $\pm 0.045$  in.) from the design depth. The cover width of the deck sheets should be within a tolerance of  $-0 + 6$  mm ( $-0$  in.  $+ 0.25$  in.) of the design width. The width of the top flange, width of bottom flange, and rib spacings should not vary more than  $\pm 0.75$  mm ( $\pm 0.030$  in.) as compared to design dimensions. Inside radii should not exceed  $8t$  ( $t$  = design thickness of steel deck).

6.2.3 *Top Flange Surface*—For assemblies in which the insulation board or vapor retarder, or both, is bonded to the steel deck by means of either a hot-melt or cold-setting adhesive, the top flange of the steel deck, after installation, shall provide a maximum contact area by means of its flat surface. The top flange surfaces must be plane without concavity or convexity exceeding 1.6 mm ( $1/16$  in.). Except at changes in direction or plane, such as at ridges, valleys, and hips, a straight edge placed across any three contact surfaces of the sheet or adjacent sheet, shall not have a gap of more than 1.6 mm ( $1/16$  in.) between the straight edge and point on the contact surface. If this condition is exceeded, the insulation in that area should be secured with mechanical fasteners (see Section 10). The conventional center to center spacing at top flanges is 150 mm (6 in.) and 200 mm (8 in.). The 150-mm (6-in.) deck module requires that at least one adhesive ribbon be placed in the center of each top flange to develop the required bond. Any deck exceeding the 150-mm (6-in.) module will require two adhesive ribbons on each top flange. The design width of the top flange surface should be not less than 75 mm (3 in.) with no interruption exceeding 1.6 mm ( $1/16$  in.) in depth. The top flange must be capable of sustaining a 1.3 kN (300-lb) concentrated load applied to a 75-mm (3-in.) diameter circle without permanent distortion or indentation exceeding 1.6 mm ( $1/16$  in.) measured from a 300-mm (12-in.) long straight edge placed parallel to the ribs.

6.2.4 *Side Lap Fastening*—The side lap fastening should be capable of resisting a concentrated load of 1.3 kN (300 lb) applied downward to the top of the underlying sheet when the load is applied to a 150- by 75-mm area (6 by 3-in.), long dimension parallel to the side lap and positioned 13 mm ( $1/2$  in.) from the web (of the underlying sheet) nearest the side lap.

6.2.5 *Deck Materials*—The steel employed in the manufacture of steel roof deck should conform to the provisions of one of the following or as provided for in the latest edition of AISI Specification for the Design of Cold-Formed Steel Structural Members:

Specifications A 446, A 529, A 570, A 606, A 607, and A 611 (refer to 2.1).

6.2.6 *Protection*—All steel to be used for roof deck should be free of oil, grease and dirt prior to shop coating. Roof deck should be galvanized coil coated or given a shop coat of primer paint. The primer coat is intended to protect the steel for only a short period of exposure in ordinary atmospheric conditions and should be considered an impermanent and provisional

coating. See 9.1 for compatibility of adhesives with steel deck. High moisture or corrosive atmosphere within the building requires special consideration.

6.2.7 *Nonconformance*—If the installed steel deck does not conform to all of the requirements in 6.1 and 6.2, the insulation board should be fastened to the deck by means of insulation fasteners in accordance with 10.1, if acceptable to the owner’s representative.

6.3 *Construction Guidelines*—The deck should be constructed in accordance with the following:

6.3.1 *Site Storage*—Steel decking should be stored off the ground with one end elevated to provide drainage and should be protected from the elements with a waterproof covering that is ventilated to avoid condensation.

6.3.1.1 Bundles in storage should be positioned so as not to cause camber, distortion, or permanent set.

6.3.2 *Erection*—Deck sheets should be placed in accordance with approved erection layout drawings and in conformance with the deck manufacturer’s standards. Roofs having a slope of 4 % ( $1/2$  in. by 12 in.) should be erected beginning at the low points to assure that end laps are shingle fashion. End laps may be either butted or lapped over supports. When lapped the recommended laps are minimum 50 mm (2 in.). If there is less than 38 mm ( $1\frac{1}{2}$  in.) bearing additional fastening should be provided and the deck end load capacity should be checked. Butted end joints gap should be maximum 25 mm (1 in.) or should be covered with a deck plate.

6.3.2.1 Take care to avoid overloading the supporting structural elements when placing bundles of steel deck or other construction loads.

6.3.2.2 Construction live loads during deck erection, insulation installation, and roofing placement should be distributed to prevent damage to the previously installed components. Mechanisms used in these operations should be limited to 1.3 kN (300 lb) per wheel located not closer than 0.76 m (30 in.) apart and bearing no less than 100-mm (4-in.) tread width.

6.3.2.3 The deck erector should cut all openings and skew cuts in the roof deck that are shown on the deck erection drawings. Openings not shown on the deck erection drawings, such as those required for stacks, conduits, plumbing vents, etc., are cut and reinforced by the trade requiring the openings.

6.3.3 *Attachment of Deck to Supporting Members:*

6.3.3.1 *Welding*—When welds are used that are not specifically calculated to carry design loads, they shall be made in accordance with the SDI Steel Roof Deck Design Manual. In general, these welds should be arc-spot welds (puddle welds) equivalent to at least a 13 mm (0.5-in.) diameter weld, or a fillet weld with a minimum length of 25 mm (1.0 in.). Welds that are calculated to transfer specific design loads should be determined in accordance with AWS D1.3-81.

6.3.3.2 *Mechanical Fasteners*—Powder-actuated or pneumatically driven fasteners or screws may be used provided the type and spacing of the fasteners satisfy the design criteria (see Appendix X2.2.3).

6.3.4 *Attachment of Deck Side Laps:*

6.3.4.1 Welds or mechanical fasteners at side laps shall occur at all supports and penetrate all thicknesses of the metal decking to the structural member.

6.3.4.2 Screws, button punching or welds may be used at all side lap connections between supports. Screws should be a minimum size No. 8. They may be self-drilling/self-tapping type.

#### 6.3.5 Location of Attachments:

6.3.5.1 Each sheet should be fastened to each end support at each side of the sheet and through interior ribs so that the spacing of fasteners along supports does not exceed an average of 300 mm (12 in.) on center. At intermediate supports, fastening should occur at each side lap and once in between, but no more than an average of 380 mm (15 in.) on center maximum.

6.3.5.2 The deck is to be supported and fastened around the building perimeter unless otherwise permitted by local regulations. At a minimum attach the side edge using the same fastener spacing that is used at interior deck side seams. For case when deck ribs are perpendicular to perimeter beam, at minimum attach deck at 300 mm (12 in.) on center. Wind uplift and diaphragm loads can require additional fasteners. Maximum attachment spacing at side lap is 1 m (36 in.) on center for all spans. Depending on project requirements, button punching, screws, or welds are acceptable. See Section 6.1.4.

6.3.6 *Diaphragm*—If deck is to serve as a diaphragm in resisting lateral loading, heavier fastenings or closer spacing of attachments, or both, may be necessary. For specific recommendations, consult deck manufacturer.

## 7. Vapor Retarder

7.1 *Design Guidelines*—Migration of moisture from high vapor-pressure (humidity) areas into the insulation and through to the underside of the roofing membrane may create problems in the roof system. In locations where such conditions exist, the designer should evaluate the need for a water vapor retarder (see ASHRAE Roofing Insulation Recommendations, AIA Roof System Design Manual and NRCA Energy Manual). When required, water vapor retarder design should be in accordance with the following provisions:

7.1.1 *Materials*—Any material which provides, in service, an unbroken barrier over the roof deck, or over a thin layer of insulation to limit water vapor transfer from inside the building into the roof system, as provided in 7.2.3, may be used (see Practice C 755).

7.1.2 *Side and End Laps*—Side and end laps of water-vapor retarder in sheet form should be sealed as recommended by the manufacturer and have adequate overlap to provide a continuous, unbroken membrane.

7.1.3 *Penetration*—All deck penetrations and roof edges should be flashed to provide continuity of the water-vapor retarder. The effectiveness of a water-vapor retarder will be reduced if penetrations and openings are not sealed.

7.1.4 *Compatibility*—Water-vapor retarders should be compatible with adjacent materials in contact therewith and maintain its integrity as a water-vapor retarder.

7.2 *Materials Guidelines*—The water-vapor retarder should conform to the following requirements:

7.2.1 *Identification*—Containers and packages should bear the manufacturer's or supplier's name and address, product name, quantity, appropriate markings, such as UL, FM, other

testing agencies, ASTM, government specifications, etc., and information relative to storage conditions.

7.2.2 *Flatness and Straightness*—When unrolled on a flat surface, the material should be free of fishmouths at edges and should lie flat. The lateral camber when unrolled should not exceed 13 mm (½ in.) in 30 m (100 ft).

7.2.3 *Permeance*—The water-vapor retarder should conform to permeance standards as follows: When tested in accordance with Test Methods E 96, Procedure A, Dessicant Method at 23°C (73.4°F), the permeance should not be more than  $2.87 \times 10^{-11}$  SI Perms (0.50 Perms).

7.2.4 *Fire Performance*—If a fire-rated assembly is required, the fire performance of the water vapor-retarder when incorporated in a roofing system should be measured by laboratory test such as Factory Mutual Construction Materials Calorimeter, Underwriters' Laboratories Test for Fire Acceptability or other appropriate fire test procedure.

#### 7.2.5 Compatibility with Adhesives:

7.2.5.1 When a water-vapor retarder is installed with a solvent-based adhesive, the adhesive and water-vapor retarder should be furnished by the same manufacturer.

7.2.5.2 Plastic water-vapor retarders should not be installed using hot bitumen, nor should hot bitumen be used to secure insulation board to plastic water-vapor retarders.

7.3 *Construction Guidelines*—The water-vapor retarder should be handled and installed in accordance with the following:

7.3.1 *Site Storage*—Water-vapor retarders should be stored under cover, off the ground, and be temperature controlled where necessary. Any covering shall include ventilation and shall protect against drippage from condensation.

7.3.2 *Construction Live Loads*—Any construction live loads during erection and roofing should be distributed to prevent damage to the previously installed components.

7.3.3 *Deck Preparation*—The deck surface should be clean and dry during application of the water-vapor retarder.

7.3.4 *Side and End Laps*—When sheet or roll materials are used, minimum 50-mm (2-in.) wide side laps should be formed on the steel-deck top flange and sealed with the adhesive recommended by the manufacturer. End laps should be a minimum of 100 mm (4 in.) in width and sealed with the adhesive recommended by the manufacturer.

7.3.5 *Tears, Punctures, and Penetration*—All tears, punctures, and penetrations, except punctures necessitated by mechanical fasteners, should be patched with water-vapor retarder material, using the manufacturer's recommended adhesive, to maintain the integrity of the water-vapor retarder.

7.3.5.1 When securing insulation over vapor retarders with mechanical fasteners, the permeance may be affected.

#### 7.3.6 Plastic Vapor Retarders:

NOTE 6—**Caution:** Plastic water-vapor retarders may be damaged when in contact with hot bitumen.

7.3.7 *Securement*—Vapor retarders shall be secured to the steel deck in accordance with the approved specifications.

7.3.8 *Completion of Roofing System*—The vapor retarder shall be covered by the insulation and roofing membrane at the end of each working day. If final surfacing is to be delayed, provide a glaze coat, when required.



## 8. Preformed Roof Insulation

8.1 *Design Guidelines*—Insulation should provide a thermal resistance required to maintain an interior environment compatible with occupancy, internal heat development projected for the building construction, and energy conservation. The designer should determine the type and thickness required to provide the desired thermal conductance value. Thermal resistance, *R*, may vary from manufacturers’ published data due to aging and other factors. Manufacturers should be consulted for in service (long term) thermal conductance. Additionally refer to the NRCA/MRCA joint bulletin “In Service R-values (ISR) for Polyisocyanurate and Polyurethane Roof Insulation Boards.” Some insulations accelerate the corrosion of roof decks and promote blistering of roof membrane in the presence of moisture, or both. Insulation manufacturers should be consulted to confirm material compatibility and proper installation within roof systems. See Specification C 1126, Section 11.3.

8.1.1 *Materials*—Roof insulation shall be of the preformed-board type and may be one or a combination of the following (latest edition):

Wood Fiber	Specification C 208
Rigid Foamed Phenolic	Specification C 1126
Expanded Perlite	Specification C 728
Mineral Fiber	Specification C 726
Rigid Polystyrene	Specification C 578
Rigid Polyisocyanurate	Specification C 1289
Rigid Polyurethane	Specification C 1013
Cellular Glass	Specification C 552

8.1.2 *Fire Hazard*—Insulations, when combined with other roofing components, may exhibit a potential fire-spreading condition. Fire protective measures should be incorporated and materials selected to limit a fire-spreading condition and to provide the desired fire endurance.

8.1.3 *Mechanical Fastening*—For single-layer applications, resilient insulations may require mechanical fasteners that permit vertical movement to avoid puncturing of roof covering under concentrated load (see section 9.2.4).

8.1.3.1 *Perimeter Fastening*—Insulation should also be fastened mechanically to the steel deck in a band not less than 1200 mm (4 ft) wide along all exterior walls or in a greater width as otherwise specified by the authority having jurisdiction.

8.1.3.2 *Mechanically Fastened Roof Systems*—Insulation fasteners may be used as sole means of securing insulation to the steel decking.

8.2 *Materials Guidelines*—The quality and performance of all roof insulation should be confirmed by specific test procedures, where applicable, or by established recognized agencies.

8.2.1 *Identification*—Packaged insulation should bear the manufacturer’s or supplier’s name and address, product name, quantity, appropriate performance and specification markings, type of board, thickness, *R* or *C* value, and where applicable, appropriate safety warnings.

8.2.2 *Shape Stability*—Insulation units should not curl or bow, when properly adhered or fastened, more than 3 mm ( $\frac{1}{8}$  in.) in 1200 mm (4 ft) when measured by placing a straightedge diagonally across a 1200-mm board and should maintain their original dimensions within the manufacturer’s tolerance for

length, width, and thickness. Certain proprietary insulations in which the manufacturer states that deformation during installation may occur, should be warranted to have no effect on the adhesion of the board or the performance of the built-up roof when installed in accordance with manufacturer’s instructions. See Practice C 550 and Methods C 209.

8.2.3 *Thermal Performance*—Thermal conductance, *C*, or resistance, *R*, stated in markings on the product or package should be determined in accordance with Test Method C 177, C 518 or C 236, provided Test Method C 518 shows comparability to absolute values in accordance with Test Method C 177.

8.2.4 *Fire Performance*—If an assembly resistant to internal fire spread is desired, the fire performance of the insulation, when incorporated in a roofing system, should be measured by a laboratory test such as the Factory Mutual Construction Materials Calorimeter, Approval Standard 4450 Class I Steel Deck Roofs, or Underwriters Laboratories Fire Test of Roof Deck Constructions, UL1256, or other appropriate fire test procedure.

8.2.5 *Compatibility with Adhesives:*

8.2.5.1 The compatibility of hot or cold adhesives with certain foamed plastic insulations should be reviewed or verified prior to use.

8.3 *Construction Guideline*—The insulation should be handled and installed in accordance with the following:

8.3.1 *Site Storage*—Insulation units should be stored off the ground and under cover. Covering should include provisions for ventilation to resist condensation and protection against drippage.

8.3.2 *Construction Live Loads*—Any construction live loads during erection and roofing should be distributed to prevent damage to the previously installed components.

8.3.3 *Deck Preparation*—Deck surface should be clean and dry during application of the insulation. Wood nailers should be installed at roof edges adjoining all eaves and roof projections and should be secured to the building structure to provide a stop at least the same thickness as the insulation. Wood nailers should be treated with a water-borne salt preservative approved by the American Wood Preserver’s Institute. Oil-based preservatives, such as creosote, are not acceptable as they are not compatible with asphalt roofing components.

8.3.4 *Application and Installation*—The insulation boards should be applied and installed as follows:

8.3.4.1 Insulation boards should be butted together. All joints over 6 mm ( $\frac{1}{4}$  in.) wide should be filled with insulation.

8.3.4.2 The units of insulation should be applied in accordance with the approved construction specifications. Insulation joints parallel to ribs of steel deck should be placed over solid bearing. Where bearing does not occur, cover the open rib with a strip of suitable support material, or cut the insulation board as required.

8.3.4.3 Insulation installed in multiple layers should have the joints offset, preferably one-half board (minimum 150 mm (6 in.)), between layers. The thickness and type of the first layer should be that approved by the authority having jurisdiction.

(a) (a) Attachment of the bottom layer should be by mechanical fasteners.

(b) Attachment of the second and subsequent layers should be by solid mopping of asphalt (use Specification D 312), or by mechanically fastening to the deck.

8.3.4.4 *Perimeter Fastening*—The first layer of insulation must be secured to the steel deck with mechanical fasteners in a band of sufficient width around the entire perimeter of the roof to satisfy the requirements of the authority having jurisdiction.

(a) Mechanical fasteners may be used as the sole means of securing insulation to the deck.

8.3.4.5 Where a vapor retarder is used, the insulation should be vented in accordance with designers recommendations (see Appendix X2.3).

8.3.5 *Completion of Roof System*—The insulation should be covered by the completed roofing membrane at the end of each working day, except that the final surfacing may be delayed provided a glaze coat is installed, if required. Some systems need not be glazed. Consult the membrane manufacturer.

## 9. Insulation Fasteners

9.1 *Design Guidelines*—Fasteners used to secure insulation shall be designed to develop a permanent attachment with the steel deck. The type of fastener assembly is the designer's option and must conform to the standards established by the authority having jurisdiction.

9.1.1 *Materials*—The fasteners may conform to the Factory Mutual Approval Guide, latest edition. The fasteners should be of steel and be a piercing type. If the fastener head is not of sufficient area, a load distribution plate or disc should be required.

9.1.2 *Physical Properties*—Fasteners should conform to the following:

9.1.2.1 All fasteners should be capable of being installed without damage resulting in loss of holding strength.

9.1.2.2 The fastener-shank length should be adequate to engage the deck and to accommodate the thickness of the roof insulation.

9.1.2.3 When used to secure resilient-type insulation board, the fastener should be capable of limited vertical movement to avoid puncturing the roof covering.

**NOTE 7—Caution:** The hardness of the steel deck should be considered when selecting the insulation fasteners.

9.2 *Materials Guidelines*—The insulation fasteners should conform to the following requirements:

9.2.1 *Identification*—Containers shall bear the manufacturer's or supplier's name and address, product name, quantity, size, and appropriate performance specification marking, etc.

9.2.2 *Corrosion Resistance*—When tested 48 h in accordance with Method B 117, the fastener may exhibit minimal traces of rust spots.

9.2.3 *Length*—The length of the fastener should be sufficient to engage the deck and to accommodate the thickness of the roof insulation. Stiffening grooves in steel deck must be taken into consideration when selecting the length.

9.2.4 *Vertical Movement*—When used to secure resilient-type insulation board, the fastener should be capable of limited vertical movement to avoid puncturing the roof covering (see section 8.1.4).

9.3 *Construction Guidelines*—The insulation fasteners should be handled and installed in accordance with the following:

9.3.1 *Protection from the Elements*—Insulation fasteners should be stored off the ground and under cover.

9.3.2 *Installation:*

9.3.2.1 Fasteners should be driven using the hammers, mallets, or mechanical devices recommended by the manufacturer or supplier.

9.3.2.2 Fasteners may be used as the sole means of securing insulation board to steel deck. Fasteners should be used to secure all insulation boards in a band of sufficient width around the entire perimeter of the roof to satisfy the requirements of the authority having jurisdiction.

9.3.2.3 Mechanical fasteners are most effective when they engage the top flange of the steel deck. It may be necessary to snap a chalk line on the insulation to aid in locating the flanges.

9.3.2.4 The fastener used should be long enough to penetrate the insulation, engage, and lock into the deck.

9.3.2.5 The minimum number and spacing of insulation fasteners should be as required by the Factory Mutual Approval Guide.

## 10. Built-Up Bituminous Roofing

10.1 *Design Guidelines*—The built-up roof covering should consist of plies of roofing sheets and an appropriate water-proofing adhesive to provide a weather-resistant covering for the roof assembly. The roof covering should not be subject to standing water, and the roof assembly should be sloped to provide drainage (see section 5.4). Delayed drainage is not recommended. If required by codes, the designer should make special provision for the standing water and cumulative additional loads. This may require a water-proofing system designed specifically to accommodate standing water.

10.1.1 *Materials*—The roofing sheets may be organic or inorganic types, saturated or coated with asphalt, or saturated with coal tar. Felts, adhesives, and surfacing material may conform to one or more of the following specifications: D 226 (Type 15, Type 30 (perforated)), D 227, D 41, D 2626, D 2178, D 312, D 450, D 2823, D 1227, D 1863, D 2822, D 2824, D 4601, D 4897, and D 4990.

10.1.1.1 The bitumen type should be compatible with the membrane, slope, and climatic conditions.

10.1.2 *Fire Hazard*—A roof-covering system must exhibit a degree of fire retardance which will not self-propagate the spread of fire (see 10.2.2).

10.1.3 *Weather Resistance*—The roof-covering system should prevent the penetration of water from the elements of the weather.

10.1.4 *Impact Resistance*—Where applicable, consideration should be given to potential damage in hail-prone geographic areas.

10.1.5 *Puncture Resistance*—Consideration should be given to potential damage from construction and maintenance traffic.

10.1.6 *Walkway*—Roof-covering areas subject to traffic should be protected by walkways distributing the load.

10.1.7 *Unusual Loads*—Roof-covering areas subject to unusual loads should be designed to protect the roof membrane.

10.2 *Materials Guidelines*—Roofing sheets should conform to the following requirements:

10.2.1 *Identification*—Roof coverings should bear the manufacturer's or supplier's name, address, product name, quantity, size, and any appropriate performance and specification marking, and other pertinent data.

10.2.2 *Fire Performance*—If a fire rating for an external fire exposure is desired, the built-up covering should be tested in accordance with Test Methods E 108.

10.3 *Construction Guidelines*—The roof covering should be handled and installed in accordance with the following:

10.3.1 *Site Storage*—Roofing felts should be stored on end, off the ground, and under cover. All construction materials stored on roof deck should be distributed to avoid exceeding design loads and to prevent damage to previously installed components.

10.3.2 *Surface Preparation*—Wood nailers as specified in 8.3.3 should be in place, and the insulation surface should be dry and cleared of debris that might damage the membrane or interfere with adhesion.

10.3.3 *Application*—The following should be observed in application of roof coverings.

10.3.3.1 Concentrated construction live loads in excess of 1.3 kN (300 lb) should be distributed to prevent damage to the previously installed components.

10.3.3.2 *Application Temperature Precautions*—The application of built-up roofing during high or low extreme ambient temperatures requires special precautions which can be obtained from the material manufacturers. Frost, ice, or moisture in any form on surfaces to be roofed should be removed.

10.3.3.3 *Bitumen Application Temperatures*—Prolonged heating at elevated temperatures should be avoided. Cleveland open-cup flash point should not be exceeded. Temperature at point of application is important for proper adhesion between plies. The optimum application condition is defined as the equiviscous temperature (EVT) range. For additional information on EVT, see NRCA Technical Bulletin No. 2-91.

10.3.3.4 *Ply Adhesion*—Bitumen should be spread the full width of the ply or over the area to be covered (see X2.8).

10.3.4 *Quality*—The roofing contractor may refuse to install any component for which they are responsible in the event they determine that the conditions are not conducive to the best quality construction.

10.3.5 *Base Ply*—If required, the base ply should be an organic-coated base sheet (Specification D 2626), inorganic base ply (Specifications D 2178, D 4601 or D 4897), or other base ply as specified. Base plies should be installed in Type II, Type III, or Type IV asphalt conforming to Specification D 312 or other adhesives as specified. Plies should have sides and ends lapped as specified and should be broomed or pressed into place to minimize air pockets and uncoated spots. Type II asphalt is not recommended in warmer regions.

10.3.6 *Roofing Felts*—The felts of roofing shall consist of organic sheets (Specifications D 226 or D 227), inorganic sheets (Specifications D 2178 or D 4490), or other felts as specified, applied in asphalt (Specification D 312) or coal tar pitch (Specification D 450) applied in quantities such that felt will not touch felt, or as specified. Type of adhesive must be

compatible with the roofing felt used and must take into consideration the slope of the roof surface. All felts should be applied shingle fashion, unless otherwise specified. The side lap width is determined by the number of plies required and the width of the sheets used. End laps should be as specified and all felts should be broomed or pressed into place to minimize air pockets and uncoated spots.

10.3.7 *Surface Finish*—The surface finish of the top ply should be applied as specified to suit the finish and the slope of the roof surface. Surface finishes may be hot or cold applied and may be emulsions, paints, cut backs, or any of several types of finishes. If a mineral aggregate surfacing is specified, a pour coat of asphalt (Specification D 312) or coal tar bitumen (Specification D 450) should be poured over the entire surface in such quantities as to completely cover the felt and provide for adequate adhesion of the aggregate (certain aggregates may require different treatments). Mineral-aggregate surfacing Specification D 1863 should be applied while the bitumen is still hot to obtain adhesion. Total embedment is not to be expected. In the event the mineral-aggregate surfacing named is not available in the area, the locally available mineral aggregate surfacing may be used, if acceptable to the specifying agency. If asphalt roll roofing (glass felt) surfaced with mineral granules (Specification D 3909) is specified, then adhere the sheet in the specified quantity of asphalt (Specification D 312).

10.3.8 *Finished Roofing*—All areas to receive the built-up roofing membrane in one day should be completed that day, except that the final surfacing of the roofing membrane may be delayed, provided a glaze coat is installed. Some systems need not be glazed. Consult the manufacturer. The perimeter of all roofed areas should be sealed with a cutoff at the end of each working day. The cutoff should be removed before the next day's work is started.

10.3.9 *Flashing*—All walls, vertical surfaces, or other penetrations should be flashed or sealed and properly joined to the built-up roof as work proceeds so that no water gets behind the flashing, or in the insulation or roofing upon completion of the construction process. The top edge of the base flashing should be sealed against the entrance of water, even when a counter flashing or other cover is used, except when perimeter venting procedures are being followed in accordance with 11.3.2.

## 11. Other Components

11.1 *Design Guidelines*—Other components include all installations that rest on supports and require penetration through the roof or joining through the roof such as air-conditioning units, pipe and pipe supports, skylights, expansion joints, edge details and other roof penetrations.

11.1.1 All installations on or above the roof should be provided with curbs or flanges that can be satisfactorily flashed to provide a watertight junction between the roof and the installation.

11.1.1.1 Pitch pans filled with asphalt or coal tar bitumen or plastic cement are the least satisfactory means of flashing roof penetrations and should be avoided.

11.1.2 All units installed on supports above the roof shall provide easy access for a worker to reach at least half the width under the unit, if necessary, to repair the roof or the equipment.



An access height of 600 mm (24 in.) is considered minimum to facilitate satisfactory repair work, when necessary, or higher if size of unit warrants.

11.1.3 All roof top units wider than 1.50 m (5 ft) or that have multiple connections through openings in the roof should be bounded by curbs extending at least 200 mm (8 in.) above the finished roof surface.

11.1.3.1 Curbs shall be installed in this manner to provide a positive means of flashing at the junction of the roof and curb, eliminate difficult roof repairs beneath units, and provide access to the mechanical equipment from the floor below, or for roof-top dismantling.

11.1.3.2 Curbs to receive roof-top units should be solidly anchored to the roof deck and structural reinforcing should be supplied as required by designer.

11.1.4 Base flashing should be isolated from wall construction to avoid distortion of the flashing due to differential movement between wall and deck. Flashing design should accommodate the anticipated thermal and structural movement.

11.1.5 Cant strips should be used at all curbs and vertical surfaces.

11.1.6 Locate equipment bases, skylights, vent stacks or other roof penetrations in a manner that will not disrupt drainage pattern of the roof.

11.1.7 Ponding of water should be avoided (see 16.4).

11.1.8 Expansion joints should be installed in the roof system wherever the deck changes direction, or where there is a change of decking materials, or where there are structural expansion joints.

11.1.9 For locations other than roof edge and nonwall supported details, the need for wood nailers should be determined by the designer or specifier.

#### 11.2 *Materials Guidelines:*

11.2.1 *Materials*—Materials used to flash curbs at roof penetrations shall be compatible with roofing membrane and other adjoining surfaces.

11.2.2 *Water Infiltration*—Flashings, when joined to roofing membrane, shall form a barrier against the penetration of water.

11.2.3 *Flexibility*—Flashing materials should have sufficient flexibility to conform to cant strip and curb.

11.2.4 *Slipping and Saging*—Flashings should not slip or sag.

11.2.5 *Weather Resistance*—Flashings should be durable and be weather resistant.

11.2.6 *Side Laps*—All side laps of base flashing should be sealed to prevent water penetration.

11.2.7 *Flanges Other Than Gravel Stops Stripped in With Membrane*—Where flanges are used, all joints should be soldered, welded, or otherwise sealed to prevent water penetration (see Appendix X2.2 for specific details). All metal flanges are to be set in a continuous application of plastic cement. Gravel stops or cleats which are secured to wood nailers should not have horizontal flanges wider than the nailer (see Specification D 2822).

#### 11.3 *Construction Guidelines:*

11.3.1 *Securement*—Adhesives used to secure flashing to curbs should be evenly spread and flashing materials carefully embedded into adhesive. The attachment of base-flashing membrane to roofing membrane should provide a watertight junction.

11.3.1.1 Base flashing materials should be mechanically secured at top edge at a maximum of 200 mm (8 in.) intervals, unless other fastening method is specified.

11.3.2 *Urgency of Seal*—Top edge of flashing should be sealed immediately upon installation to avoid water penetration behind flashing and under roofing or into insulation. Where vented flashing is to be provided, and if seal is omitted, counter flashing is to be installed as soon as possible to prevent water penetration.

## ROOF SYSTEM EVALUATION

### 12. Field Inspection

12.1 The designer, general contractor, and roofing subcontractor involved should provide supervision during application and inspection after application of the steel deck to ensure adherence to 6.1, 6.2, and 6.3 criteria prior to the beginning of the installation of the vapor retarder, if any, roof insulation, and built up roofing as specified in Sections 7-11 inclusive.

12.2 After the fact, corrective action may be difficult and costly, and may compromise the roof. Good in-process inspection identifies deficiencies at a time when corrective action can be taken.

12.3 In accordance with the state of the art of the built-up roofing industry, bitumen application at low winter or high summer temperatures or unusual job conditions may result in isolated variations.

12.4 Inspection of the roof assembly, or portions of that assembly, must be based on competent inspection and must consider compliance or non-compliance with the construction specifications. In order for roof inspectors to familiarize themselves thoroughly with the various types of equipment, proper checklists should be completed.

12.5 It can be misleading to judge the quality of a membrane with respect to performance and durability on the basis of the amount and uniformity of bitumen between individual plies. During state-of-the-art bituminous membrane construction, deviations from the specified interply bitumen rates are expected. A continuous, firmly bonding film of interply bitumen is the critical characteristic.

12.5.1 The important principles are:

(1) The interply layer of bitumen should be a continuous, firmly bonding film, and

(2) If on-site inspection reveals a lack of continuous, firmly bonding film, adjustments should be made immediately in application procedures, and some determination should be made as to the scope of the discrepancy and appropriate remedial action taken.

### 13. Testing

13.1 *Field Test Method for Uplift Resistance of Roof System Assemblies:*

13.1.1 This is a recognized nondestructive field test identified as Test Method E 907 and determines the resistance of the



roof system assembly to uplift at the time of application of a new roof or during the investigation of a roof problem.

#### 14. Field Verification

14.1 Test cuts, if required, on a completed built-up roof should not be considered an adequate substitute for field quality control and inspection during roof application. Test cuts should be made prior to surfacing in order that corrective action can be taken if necessary.

14.2 For new roofs, test cuts should be made in accordance with Practice D 3617.

14.3 For old roofs or finished roofs having floodcoat and gravel, test cuts should be made in accordance with Practice D 2829.

#### 15. Certification

15.1 When required by the purchase order or contract, a manufacturer's or independent testing laboratory certification, or both, shall be furnished to the purchaser that the material was manufactured, sampled, tested, and inspected in accordance with the material specification and meets the requirements. When specified in the purchase order or contract, a report of the test results shall be furnished.

15.2 Final verification and historical record should be retained by the building owner for future historical evaluation, and may be in accordance with the historical record form (see Fig. 8).

#### 16. Roof Maintenance

16.1 Periodic inspections and maintenance should be made by competent personnel (such as crew foreman or roofing superintendent with five or more years experience) at least once a year, preferably in the spring after severe winter conditions. This inspection frequently discloses minor defects which were not apparent when the new roofing or re-roofing was completed. The original completion survey specified in 15.2 should be updated and initialed after these yearly inspections.

16.2 Additional inspections should be conducted after any severe weather (for example, ice storms, high winds, sudden temperature changes, etc.).

16.3 One method of obtaining these inspections is for the owner to enter into an inspection agreement with a roofing consultant.

16.4 Accumulation of absorbent material, such as snow, leaves, etc., on any portion of a flat or low incline roof may upset designed drainage patterns and should be prevented by regular inspections and removal. Capillary action may enable the absorbent material to retain water to a higher elevation than would be possible by ponding.

16.5 See historical record form (Fig. 8).

#### 17. Keywords

17.1 bituminous; mechanical attachment; roof insulation; roofing membranes; steel deck



OWNER \_\_\_\_\_ REPRESENTATIVE \_\_\_\_\_

ADDRESS \_\_\_\_\_

BUILDING IDENTITY \_\_\_\_\_

BUILDING NO. \_\_\_\_\_ USED FOR \_\_\_\_\_

Permanent \_\_\_\_\_ Temporary \_\_\_\_\_ Year Roof was Applied \_\_\_\_\_

Area of Roof: Square Meters \_\_\_\_\_ Square Feet \_\_\_\_\_

Kind of Steel Deck: Type \_\_\_\_\_ Gage \_\_\_\_\_ Maximum Span \_\_\_\_\_ Depth \_\_\_\_\_

Finish: Painted \_\_\_\_\_ Galvanized \_\_\_\_\_ Galvanized and Painted \_\_\_\_\_

Fastening System: Welded \_\_\_\_\_ Screwed \_\_\_\_\_ Clipped \_\_\_\_\_

Power Actuated \_\_\_\_\_ Pneumatically Actuated \_\_\_\_\_

Slope of Roof: Flat \_\_\_\_\_ Slope \_\_\_\_\_ %, Inches per Foot \_\_\_\_\_

Type of Built-up Roof: Roof Bonded or Guaranteed: Yes \_\_\_\_\_ No \_\_\_\_\_

Asphalt: Aggregated Surface \_\_\_\_\_ Smooth Surface \_\_\_\_\_ Cap Sheet \_\_\_\_\_

Cold Process \_\_\_\_\_ Years Bonded or Guaranteed \_\_\_\_\_

Coal-Tar Bitumen \_\_\_\_\_ Coal-Tar Pitch \_\_\_\_\_

Kind of Surfacing: Slag \_\_\_\_\_ Gravel \_\_\_\_\_ Crushed Stone \_\_\_\_\_

Other Surfacing (Name) \_\_\_\_\_

Number of Plies of Felt: 2 \_\_\_\_\_ 3 \_\_\_\_\_ 4 \_\_\_\_\_ 5 \_\_\_\_\_

Kind of Felt: Organic \_\_\_\_\_ Coated \_\_\_\_\_ Uncoated \_\_\_\_\_

Glass Fiber \_\_\_\_\_ Coated \_\_\_\_\_ Uncoated \_\_\_\_\_

\*Asbestos \_\_\_\_\_ Coated \_\_\_\_\_ Uncoated \_\_\_\_\_

Kind of Base Ply Sheet (if used) \_\_\_\_\_

Insulation: Yes \_\_\_\_\_ No \_\_\_\_\_ Thickness \_\_\_\_\_

Type of Insulation \_\_\_\_\_ Number of Layers \_\_\_\_\_

How Adhered to Deck \_\_\_\_\_

Vapor Retarder: Yes \_\_\_\_\_ No \_\_\_\_\_ Type \_\_\_\_\_ Adhesive \_\_\_\_\_

Venting: Yes \_\_\_\_\_ No \_\_\_\_\_ Type \_\_\_\_\_

Flashings:

Type of Base Flashings:

Composition \_\_\_\_\_ Kind \_\_\_\_\_

Cant Strip: Yes \_\_\_\_\_ No \_\_\_\_\_ Describe \_\_\_\_\_

Other Flashings: (Describe) \_\_\_\_\_

Counter or Cap Flashings: Yes \_\_\_\_\_ No \_\_\_\_\_

Metal \_\_\_\_\_ Composition \_\_\_\_\_ Kind \_\_\_\_\_

Other \_\_\_\_\_

Edge Details (Describe) \_\_\_\_\_

Gravel Stop \_\_\_\_\_ Parapet Walls \_\_\_\_\_

Reglet (Describe) \_\_\_\_\_

Drainage System (Describe): \_\_\_\_\_

Roof Drains \_\_\_\_\_

Scuppers \_\_\_\_\_

Gutters \_\_\_\_\_

GENERAL CONTRACTOR: Name \_\_\_\_\_ Phone \_\_\_\_\_

Address \_\_\_\_\_ City \_\_\_\_\_ State \_\_\_\_\_

MANUFACTURERS AND SUPPLIERS OF COMPONENTS:

Steel Deck Manufacturer \_\_\_\_\_

Steel Deck Applicator \_\_\_\_\_

Roofing Contractor \_\_\_\_\_

Vapor Retarder Manufacturer \_\_\_\_\_

Adhesive Manufacturer \_\_\_\_\_

Insulation Manufacturer \_\_\_\_\_

Mechanical Fasteners Manufacturer \_\_\_\_\_

Bitumin Supplier \_\_\_\_\_

Felt Manufacturer \_\_\_\_\_

Surfacing Materials Supplier \_\_\_\_\_

Other Collateral Products Manufacturers \_\_\_\_\_

Date \_\_\_\_\_

PREPARED BY \_\_\_\_\_

FIG. 8 Historical Record Form

\* Special consideration should be made in installing and/or removal of asbestos containing materials.

APPENDIXES

(Nonmandatory Information)

X1. DESIGN REFERENCES AND ILLUSTRATIONS

X1.1 The line or joint where roofs meet walls or where roofs terminate can be the most vulnerable areas of the whole structure. Many reports of leaking walls, paint failure, efflorescence and roof failures can be traced back to poor flashing details. Conversely, many leaks or failures attributed to poor flashings or roof edge design can be caused by inadequate wall design or maintenance.

X1.2 Flashings are generally subjected to the worst possible conditions on the roof. They usually join two planes (roof to wall) of different materials with different thermal characteristics. They are exposed to severe weathering and to mechanical damage from traffic over the roof. Many built up roofs do not perform satisfactorily because not enough consideration was given to the flashing or wall design during the planning stages. Often the designer or owner will depend on the mechanical engineer or equipment supplier to devise the flashing details for the design of supports for equipment on the roof of the building. This does not always result in the best conditions for the roof. The equipment supplier or installer is primarily concerned with their equipment and cannot always be expected to be concerned about the roof. An incorrect flashing can result in a great deal of damage to the roof and contents of the building.

X1.3 In developing the details shown in Figs. X1.1-X1.22, taken from the NRCA Roofing & Waterproofing Manual, one of the objectives was to separate the fabric or felt part of the flashing system from the metal part. Another objective was to keep the metal work above the highest water line on the roof wherever possible. Since the metals used in flashing systems have different thermal movement characteristics than the fabric or felt parts, any differential movement of the metal is likely to cause tears or cracks in the fabric or felt or even in the roof membrane, if the metal is tied to the fabric or felt in any way. This can be controlled by nailing or fastening the metal at intervals as close as 76 mm (3 in.) on center. With heavier gage metals or extrusions, the metal should be kept above the water line, or the metal can be attached so that it is free to move without causing damage to the fabric or felt parts of the flashing system.

X1.4 The details shown in this annex indicate the use of wood nailers at eaves and other terminal points of the insulation. The nailers provide protection for the edge of the insulation and also provide anchorage for blow-off protection. The nailers must be anchored securely to the deck system to be effective. Bolting is preferred over nailing to provide anchorage to the deck. Treated wood should be used for nailers, but the type of treatment should be chosen with caution. The oil used as a carrier for many lumber treatments can act as a solvent on the roofing materials and cause bitumen drippage.

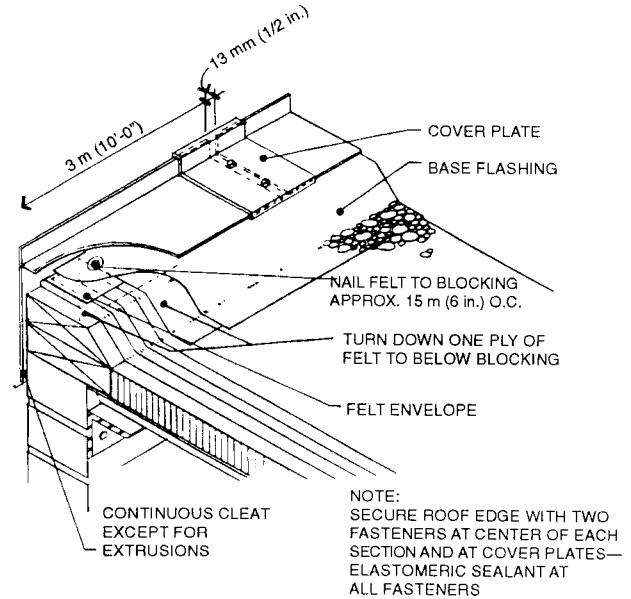

NOTE 1—This detail should be used only where the deck is supported by the outside wall.

NOTE 2—Metals of 22 gage steel, 1.3 mm (0.050 in.) aluminum, 24 gage stainless steel or heavier are appropriate for this detail. Metals of this weight are very rigid when formed, and fastening at the center-line and joint cover will allow thermal expansion and contraction without damaging the base flashing material.

NOTE 3—Attach nailer to masonry wall. Refer to Factory Mutual Data Sheet 1-49.

NOTE 4—Wood blocking may be slotted for venting where required.

FIG. X1.1 Heavy Metal Roof Edge Detail

Water- or gas-borne treatments may be preferred.

X1.5 Pitch pans or pitch pockets have not been shown in these details. Pitch pockets or pans, by their design, do not remain continuously watertight. Their use should not be encouraged since better methods are available to accomplish the same end. Pitch pans or pockets require frequent inspection and maintenance, and usually a great deal of damage can occur before the leak around a pitch pocket or pan is evident.

X1.6 Roof decks are often used as a base for the installation of heating and air conditioning units, thereby causing many problems for the roofing contractor and owner. These problems are generally brought about as a result of poor design and a lack of clearly defined responsibility among all the involved contractors, material suppliers, and manufacturers. Most roofing problems involving rooftop equipment can be attributed to one or more of the following deficiencies:

X1.6.1 Structural steel and roof deck not designed to carry adequately the weight of the unit, causing deflection and consequent ponding of water.

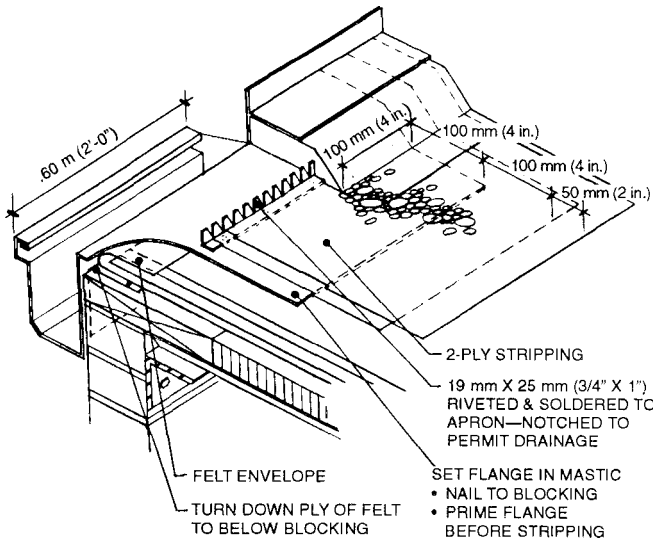

NOTE 1—This detail should be used only where the deck is supported by the outside wall.

NOTE 2—This detail can be adapted to roof edges shown in Figs. X1.8 and X1.16. It is easy to install after the building is completed to relieve standing water in areas along the roof edge. All roof surfaces should be sloped to drain.

NOTE 3—Attach nailer to masonry wall. Refer to Factory Mutual Data Sheet 1-49.

NOTE 4—Wood blocking may be slotted for venting where required.

FIG. X1.2 Scupper Through Roof Edge

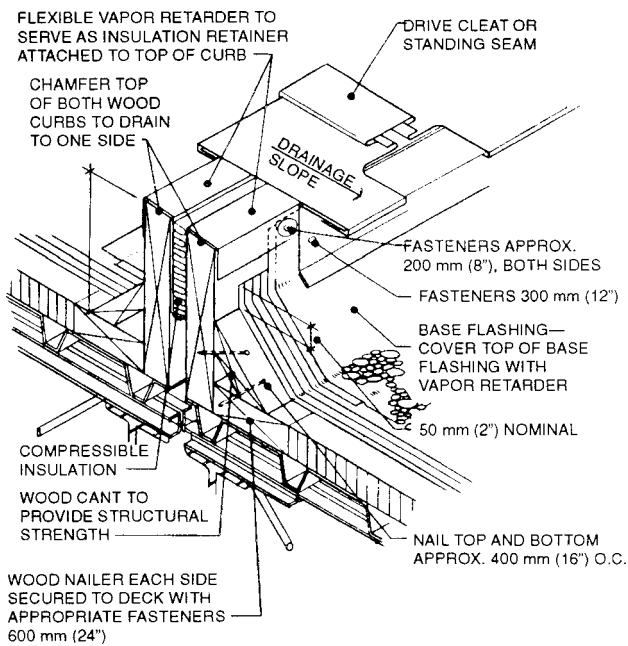

NOTE 1—This detail allows for building movement in both directions. It has proven successful for many years.

FIG. X1.3 Expansion Joint

X1.6.2 Improper flashing of pipes and electrical conduit that extend through the roof to service the unit.

X1.6.3 Improper curb design for the unit.

X1.6.4 No provision made for walkways to service the roof top unit.

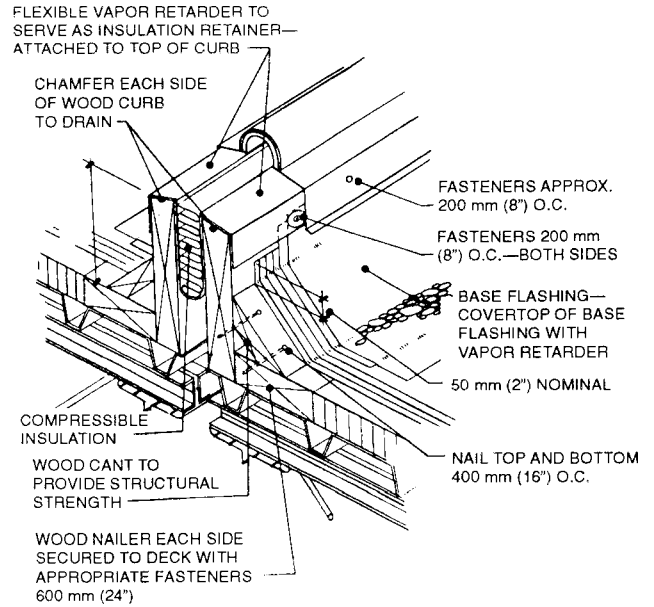
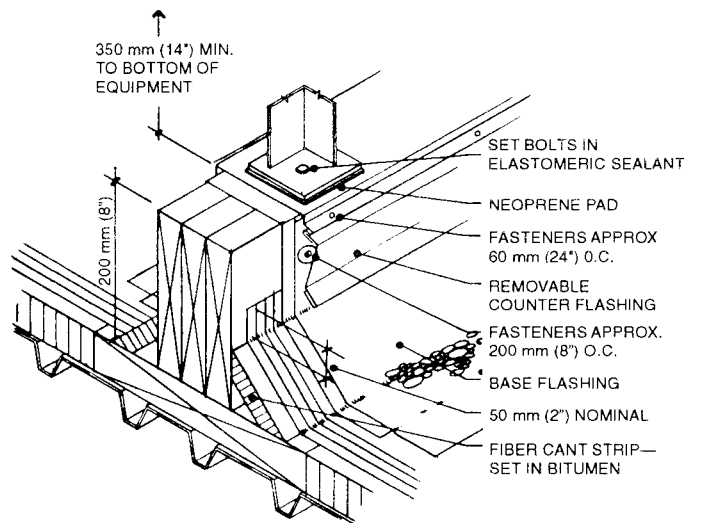

FIG. X1.4 Expansion Joint



NOTE 1—See Factory Mutual Data Sheet 1-49, Perimeter Flashing.

NOTE 2—This detail allows for roof maintenance around the equipment or sign. The continuous support is preferred in lightweight roof systems since the equipment weight can be spread over more supporting members. Where heavy structural systems are used, or where the load can be concentrated over a column, Fig. X1.14 is preferred. Clearance must be provided for removal and replacement of roofing and flashing between parallel supports.

FIG. X1.5 Equipment or Sign Support

X1.6.5 Improper drainage.

X1.7 It is essential that adequate provisions be made for the proper flashing of such units, including their service piping, and that access be provided to both roofing and flashing should future repairs be required. It should be emphasized that the roofing contractor is responsible only for watertight connections to the curb of the roof-top units and cannot be responsible for water entering the building through the unit itself. The unit should be placed on a curb meeting standards (Fig. X1.17).



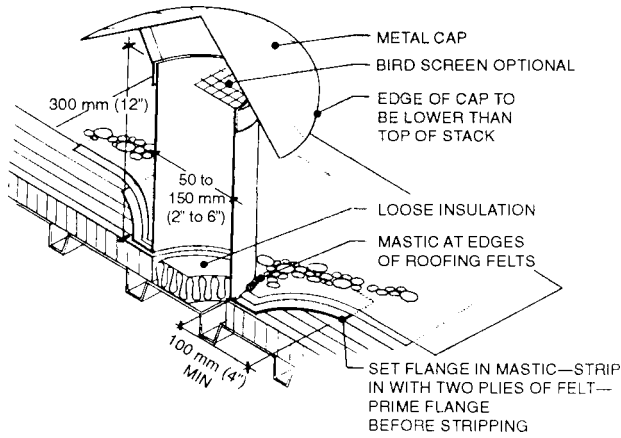

NOTE 1—This detail is used to vent vapor pressure from the roof system. Moisture may have entered the roof system due to leaks, faulty vapor retarders or during construction. The spacing is determined by the type of insulation used. It is sometimes used for new roofs when vapor retarders are used and a venting system is desired. Condensation may be reduced by the use of insulated stacks.

**FIG. X1.6 Roof Relief Vent**

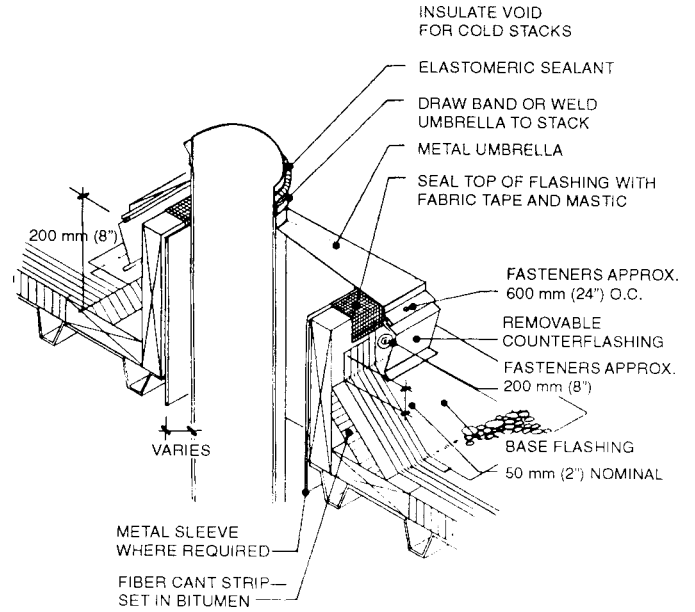

NOTE 1—This detail allows the opening to be completed before the stack is placed. The metal sleeve and the clearance necessary will depend on the temperature of the material handled by the stack.

**FIG. X1.7 Stack Flashing**

These standards are given in the figures in this annex.

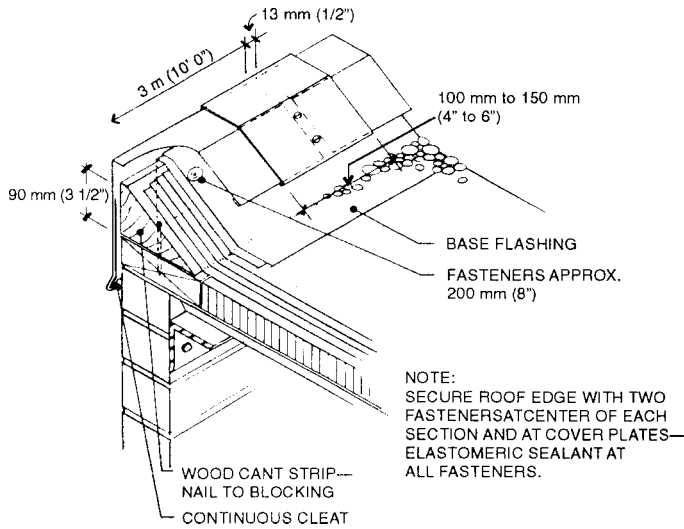

NOTE 1—This detail should be used only where the deck is supported by the outside wall.

NOTE 2—This detail is similar to Figs. X1.1 and X1.16. The cant placed as shown will result in a higher fascia line. The No. 15 felt shown behind the fascia provides protection for the flashing edge and seals the system until the metal work is installed.

NOTE 3—Attach nailer to masonry wall. Refer to Factory Mutual Data Sheet 1-49.

NOTE 4—Wood blocking may be slotted for venting where required.

**FIG. X1.8 Alternative Light Metal Roof Edge Detail**

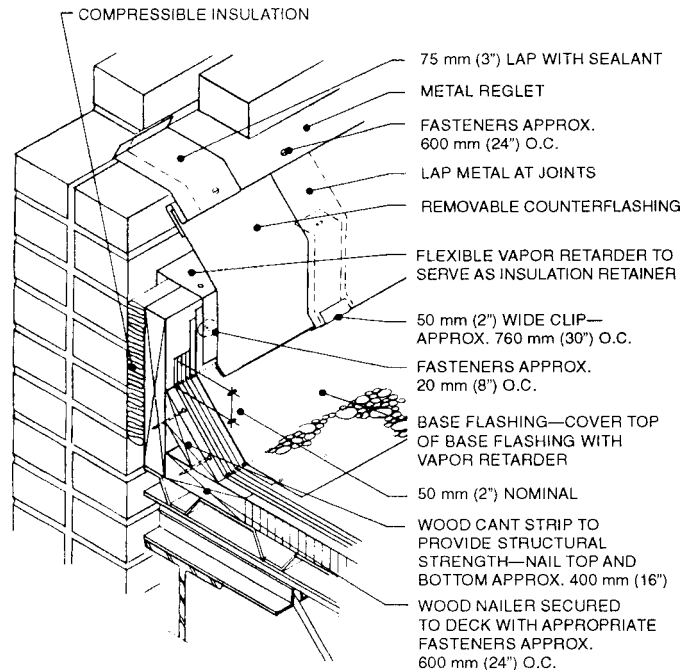

NOTE 1—This detail allows wall and deck to move independently.

NOTE 2—This detail should be used where there is any possibility that differential movement will occur between the deck and vertical surface, such as at a penthouse wall. The vertical wood member should be fastened to the deck only if it is possible to use a different method of joining the two piece flashing system. This is one satisfactory method. Others are possible.

**FIG. X1.9 Base Flashing for Non-Wall Supported Deck**

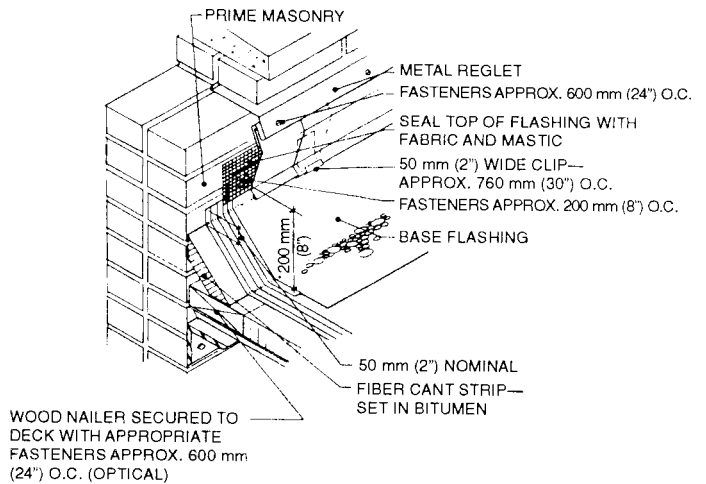

NOTE 1—This detail should be used only where the deck is supported by the wall.

NOTE 2—This detail is similar to Fig. X1.9. The joints in the two pieces of flashing should not be soldered. Breaks in soldered joints could channel water behind the flashing. Clips at the bottom of the flashing are not necessary on flashing with a face dimension of 6 in. or less.

NOTE 3—See Fig. X1.9 for preferred construction.

**FIG. X1.10 Base Flashing for Wall Supported Deck**

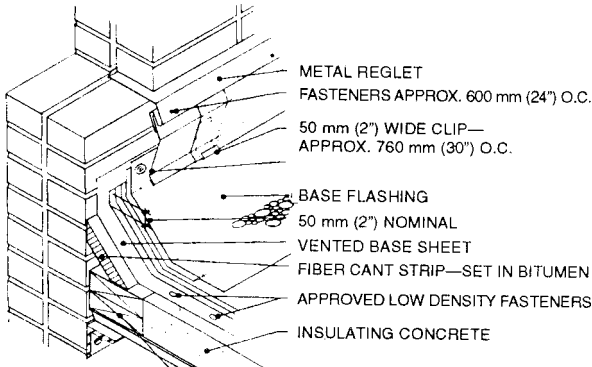

WOOD NAILER SECURED TO DECK WITH APPROPRIATE FASTENERS APPROX. 600 mm (24") O.C.

NOTE 1—This detail should be used when reroofing over existing insulation.

NOTE 2—All plies and flashing to be solidly mopped to base sheet. Care should be used not to seal the base sheet to the parapet.

NOTE 3—See Fig. X1.9 for preferred construction.

**FIG. X1.11 Base Flashing for Vented Base Sheet**

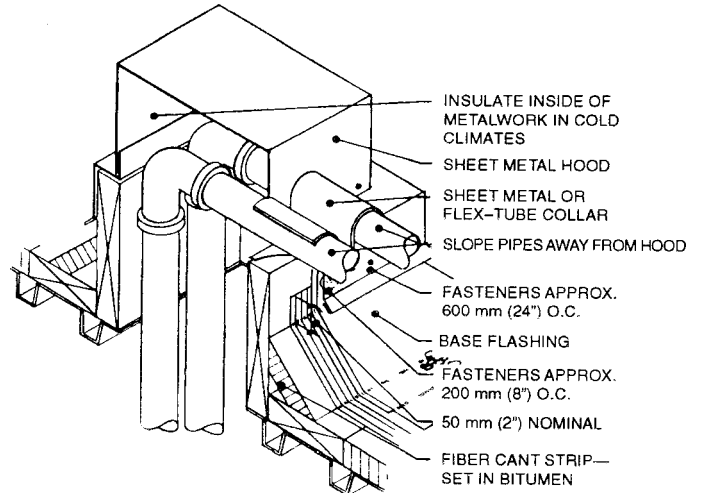

NOTE 1—This detail illustrates another method of eliminating pitch pockets. It is a satisfactory method of grouping piping that must come up above the roof surface.

**FIG. X1.13 Piping Through Roof Deck**

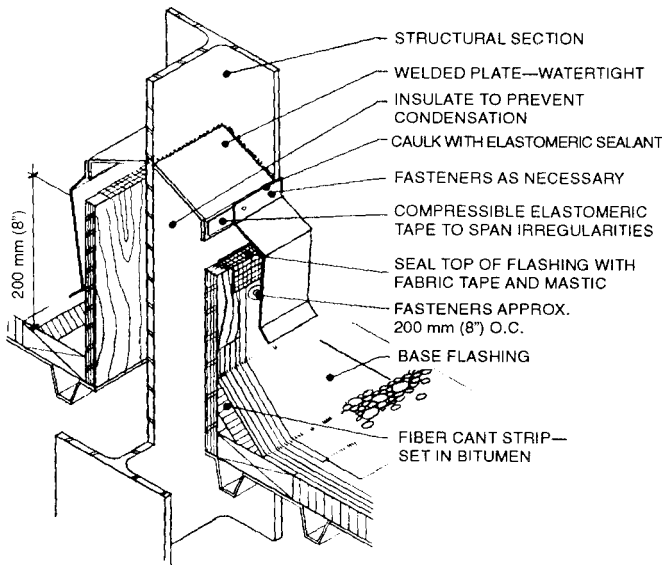

NOTE 1—This detail illustrates one method of eliminating pitch pockets. The curbed system allows for movement in the structural member without disturbing the roofing system.

**FIG. X1.12 Flashing Structural Member Through Roof Deck**

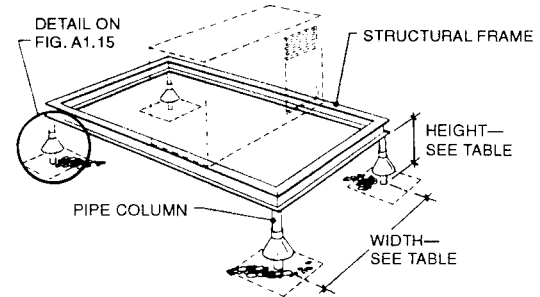

WIDTH OF EQUIPMENT	HEIGHT OF LEGS
UP TO 600 mm (24")	350 mm (14")
600 to 900 mm (24" to 36")	450 mm (16")
900 to 1200 mm (36" to 48")	600 mm (24")
1200 to 1500 mm (48" to 60")	760 mm (36")
1500 (60") AND WIDER	1200 mm (48")

NOTE 1—This detail is preferable to Fig. X1.5 when the concentrated load can be located directly over columns or heavy girders in the structure of the building. This detail can be adapted for other uses such as sign supports.

**FIG. X1.14 Mechanical Equipment Stand**

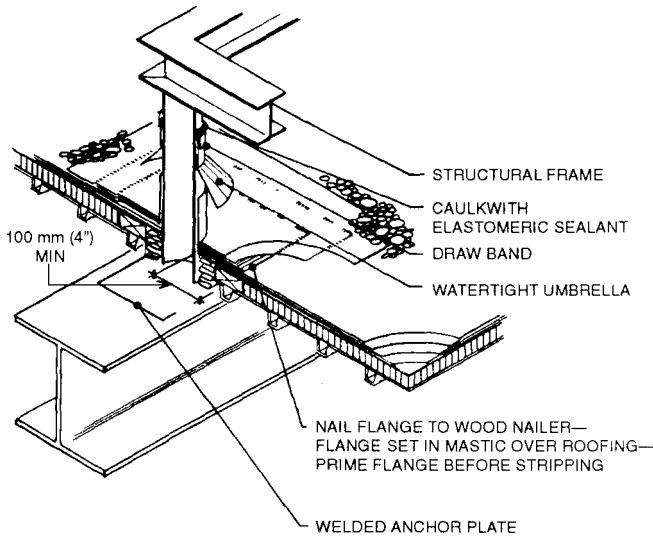

FIG. X1.15 Insulated Deck Steel Frame

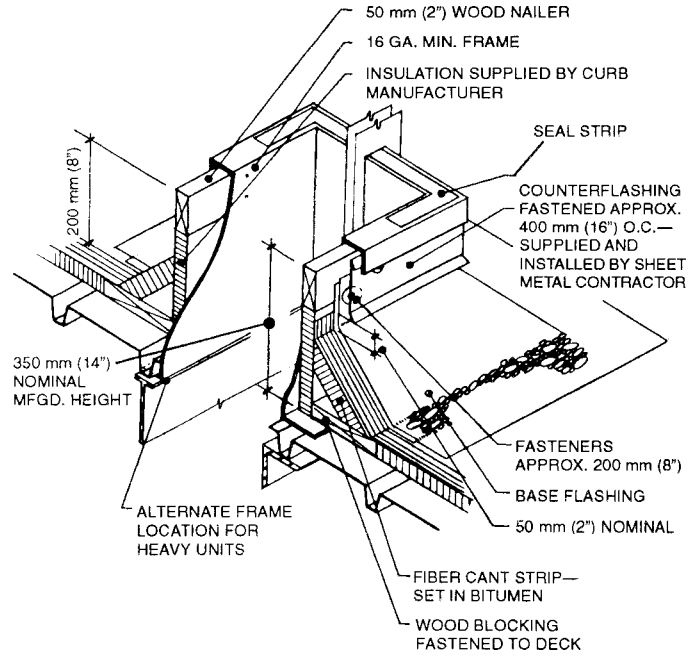
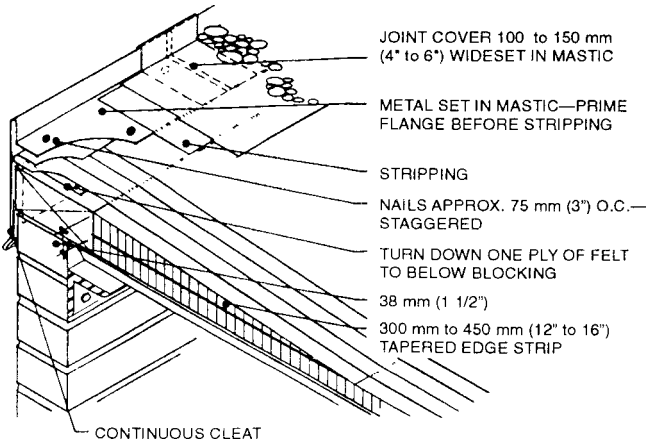

FIG. X1.17 Curb Detail for Rooftop Air-Handling Units



CONTINUOUS CLEAT

NOTE 1—Envelope shown for coal tar pitch and low slope asphalt.

NOTE 2—Attach nailer to masonry wall. Refer to Factory Mutual Data Sheet- 49.

NOTE 3—This detail should be used only where deck is supported by the outside wall.

NOTE 4—This detail should be used with light gage metals such as 16-oz copper, 24 gage galvanized, or 1.0 mm (0.040 in.) aluminum. A tapered edge strip is used to raise the gravel stop. Frequent nailing is necessary to control thermal movement.

NOTE 5—Wood blocking may be slotted for venting when required.

FIG. X1.16 Light Metal Roof Edge Detail

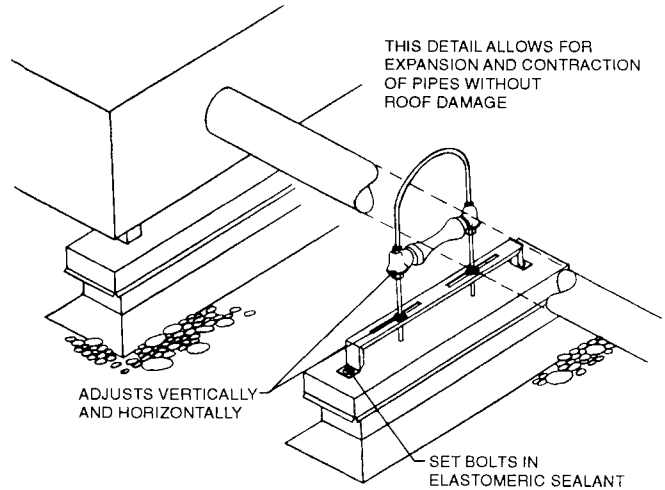

NOTE 1—There is opposition to pipes and conduits being placed on roofs. However, where they are necessary, this type of pipe roller support is recommended.

FIG. X1.18 Pipe Roller Support Detail



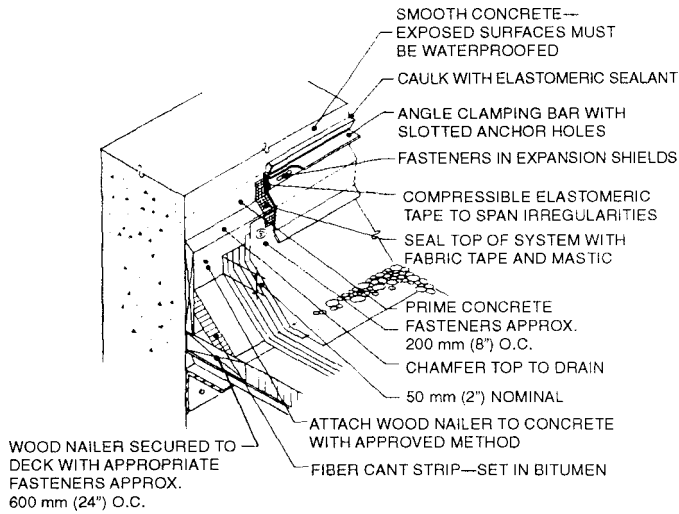

NOTE 1—Where deck is supported by and fastened to the concrete wall, vertical wood nailer should be secured to the wall with suitable fasteners.

**FIG. X1.19 Counter Flashing for Concrete Walls or Parapets**

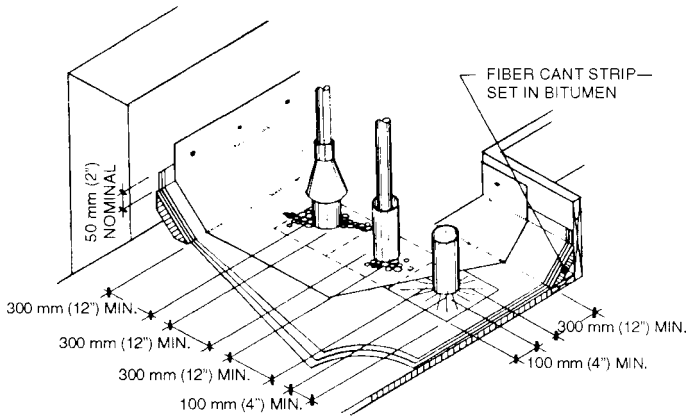

**FIG. X1.20 Clearances for Multiple Pipes and from Walls and Curbs**

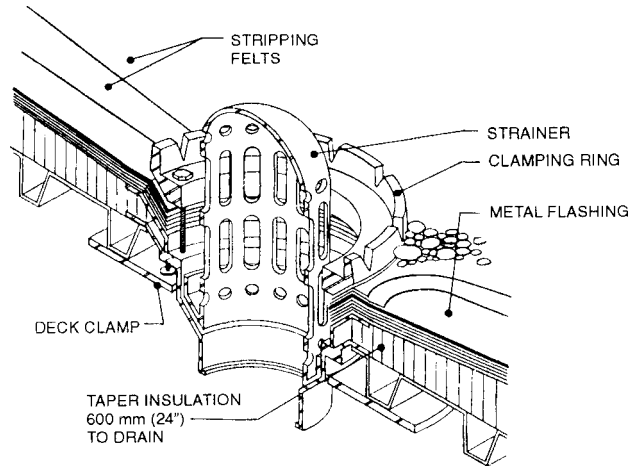

NOTE 1—Metal flashing is minimum 760 mm (30 in.) square, 1 kg to 1.8 kg (2.5 to 4 lb) lead or 0.5 kg (16 oz.) soft copper flashing set on finished roof felts in mastic. Prime top surface before stripping.

NOTE 2—Membrane plies, metal flashing, and flash-in plies extend under clamping ring.

NOTE 3—Stripping felts extend 100 mm (4 in.) and 150 mm (6 in.) beyond the edge of flashing sheet.

**FIG. X1.21 Roof Drain**

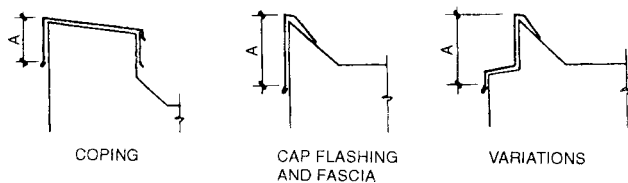

Recommended Minimum Gauges for Fascia Shown Above

Exposed Face Without Brakes "A" Dimension, mm (in.)	Galvanized Iron	Cold Rolled Copper	Aluminum 3003-H14
Up to 150 mm (6) FACE	26 GA.	0.45 kg (16 oz)	1 mm (0.040) 18 GA.
150 mm to 200 mm (6 to 8) FACE	24 GA.	0.45 kg (16 oz)	1.3 mm (0.050) 16 GA.
200 mm to 250 mm (8 to 10) FACE	22 GA.	0.57 kg (20 oz)	1.6 mm (0.064) 14 GA.
250 mm to 350 mm (10 to 15) FACE	20 GA.	ADD BRAKES TO STIFFEN	2.0 mm (0.080) 12 GA.

NOTE 1—When using the table other items should be considered such as the method of fastening. If the metal can only be fastened at 3 m (10 ft) intervals, a heavier gage is required.

**FIG. X1.22 Gage or Thickness for Metal Fascia Exposed to View**

## X2. COMMENTARY

### X2.1 Introduction

X2.1.1 The following appendix is presented for the guidance of those interested in this specification and is for information only. References to specific agencies or organizations include those known to address particular commentary. There may be other agencies or organizations not referenced which may also address the subject of the commentary.

### X2.2 Steel Deck Securement—Attachment of Deck to Supporting Members

X2.2.1 *Welding*—Welds that are calculated to carry design loads should be made in accordance with all the applicable details and techniques contained in the referenced AWS and

AISI specifications (see 6.3.3.1). When welds are not calculated to carry specific design loads, they should meet the following criteria:

X2.2.1.1 Puddle welds shall be at least 13 mm (½ in.) in diameter, or an elongated weld having an equal perimeter. Fillet welds when used shall be at least 25 mm (1 in.) long. Weld metal shall penetrate through all layers of deck material into supporting members at end laps and side joints. Care should be exercised in the selection of electrodes and amperage to provide sound welds and prevent high amperage blowholes. (The welding rod selection and the amperage are usually left to the preference of the individual welder.) Welds are made from the top side of the deck with the welder following directly

behind the placement crew. Welding washers are not necessary for steel deck with design thickness of 0.71 mm (0.028 in.) or heavier.

**X2.2.2 Screws**—The allowable load value per screw used to determine maximum fastener spacing for either self drilling or standard metal type is based on minimum size 12 and structural support thickness of 1.5 mm (0.060 in.).

**X2.2.3 Powder-Actuated or Pneumatically Driven Fasteners**—The allowable load values per fastener used to determine the maximum fastener spacing is based on a minimum structural support thickness of not less than 3.2 mm ( $\frac{1}{8}$  in.) and on the fastener providing an 8-mm ( $\frac{5}{16}$ -in.) diameter minimum bearing surface (fastener head size). Powder-actuated and pneumatically driven fasteners are recognized as viable anchoring methods, provided the type and spacing of said fasteners satisfies the design criteria. Documentation in the form of test data, design calculations, or design charts shall be submitted by the fastener manufacturer as the basis for obtaining approval.

**X2.2.3.1 Fastener Spacing**—Standard-style deck sheets are available in widths of 460, 610, 760, and 915 mm (18, 24, 30, and 36 in.), depending on the manufacturer. The location and number of fasteners required for satisfactory attachment of standard deck to supporting structural members are as follows:

(1) All edge ribs plus a sufficient number of interior ribs to limit the spacing between adjacent points of attachment to 300 mm (12 in.).

(2) Side laps of individual sheets must be fastened together between supports and fasteners must not exceed 1 m (36 in.) on center.

### **X2.3 Water Vapor Retarders**

**X2.3.1** Water vapor will move to and condense in or on materials which are at or below the dew point temperature. A familiar example is the condensation of water on cold glass surfaces during winter and the frosting of cold-drink containers in summer.

**X2.3.2** The underside of the roofing membrane provides a condensing surface, especially in winter. Water vapor can and will migrate from within the building to the underside of the membrane, and may accumulate within the membrane. Blisters may occur when this trapped water is heated by solar radiation. Vapor retarders beneath the insulation are intended to retard the flow of water vapor into the roofing system.

**X2.3.3** Some typical sources of moisture during and after construction are as follows:

**X2.3.3.1** Fresh concrete, 100 mm (4 in.) slab, 8900 N (1 ton) water/92.5 m<sup>2</sup> (1000 ft<sup>2</sup>).

**X2.3.3.2** Gypsum, 50 mm (2 in.) slab, 24 000 N (2.7 ton) water/92.5 m<sup>2</sup> (1000 ft<sup>2</sup>).

**X2.3.3.3** Gypsum plaster, 25 mm (1 in.) slab, 7100 N (0.8 ton) water/92.5 m<sup>2</sup> (1000 ft<sup>2</sup>).

**X2.3.3.4** Temporary heat during construction.

**X2.3.3.5** Wet process manufacturing, such as, papermills, food canneries, textile mills, etc.

**X2.3.3.6** Building usage, such as, auditorium, swimming pools, kitchens, etc.

**X2.3.4** The designer will determine the design and quality of the vapor retarder selected. After the roof has been installed, ventilation should be provided to exhaust excess moisture.

### **X2.4 Roof Insulation: Rigid-Board Type**

**X2.4.1** Insulations are only one component of a roof assembly. They must provide the required control of heat flow in the roof system and also be compatible with all the other elements of the assembly. A function of rigid-board type of roof insulation, when used in conjunction with steel roof decks, is to provide a satisfactory base on which the built-up roof membrane is installed. The insulation must also possess compressive, shear, tensile, flexural, and cohesive strength sufficient to withstand foot traffic and construction loads during and after installation. It must withstand impact loads, and also stresses caused by thermal variations. Insulations must have sufficient strength to prevent failure due to uplift forces, and be capable of accommodating various mechanical fastening methods to assure satisfactory performance. Roof insulation should be protected and kept dry during delivery, storage, application, and installation.

### **X2.5 Insulation Fasteners**

**X2.5.1** Insulation fasteners provide positive mechanical securement of roof insulation to the steel deck. They should always be used to secure insulation near the roof edge where wind uplift forces are greatest. Fastener length should be selected to accommodate the insulation thickness and the depth of stiffening rib, if present in the steel-deck flange. Most fasteners require a steel disk or plate to distribute uplift forces on the insulation surface. The spacing of fasteners is determined by laboratory uplift test procedures. Factory Mutual publishes recommended spacings in the Factory Mutual Approval Guide. Factory Mutual Data Sheet 1-28 shows the recommended patterns graphically for each size and type of insulation board.

### **X2.6 Membrane**

**X2.6.1** The importance of keeping all materials used in the construction of the built-up roof dry prior to and during application cannot be overstressed. Felts and coated rolls will take up moisture if left exposed to the weather for extended periods of time. These products should be stored off the ground and under cover prior to application. Applied felts, unless permitted by the manufacturer, should not be left exposed without the final surfacing or a glaze or seal coat. Should foaming of the hot bitumen occur during application, it is an indication the moisture is present on the surface or in the felts. This condition can lead to serious blistering if the moisture is trapped between the plies. Under these circumstances, roofing should not proceed until material or surfaces to be mopped, or both, do not foam. Ply adhesion is essential to proper roof performance and adequate ply adhesion can only be obtained when surfaces are dry and the bitumen is at the proper application temperature at point of application.

### **X2.7 Application Variances**

**X2.7.1** The application of roofing components is not a science but an art. Most generally they are installed by hand or

sometimes using felt layers, to assist in laying down the roofing felts, or chain mops in applying the bitumen. There is no method yet devised to uniformly control the amount of bitumen used to install roofing, insulation, or vapor retarder. The same holds true in application of gravel as a top surfacing or a mopping of bitumen as a top surfacing. The amount of bitumen applied can vary day by day with the fluctuation of ambient conditions such as temperature and wind. It can and will also vary with the individual using the mop, or operating a chain mop or felt layer, or both, and should be adjusted accordingly to meet the specified quantity.

X2.7.2 Much of the criteria on application of roofing components has been developed under laboratory conditions, of temperature, wind and humidity. Until field conditions are studied and measured under all climatic variations, laboratory criteria can only be used as a guide.

X2.7.3 While voids are undesirable, it must be recognized that it is impossible to build up a roof totally free of voids. Hot bitumen, after being mopped or applied with a felt layer or chain mop, may contain air voids.

X2.7.4 No roofing contractor can guarantee the system installed as to wind uplift or fire ratings, or both. These systems have been designed and tested by others and the roofing contractor should not bear the responsibility if a failure develops, providing the system is installed in accordance with the instructions of the designer and the recommendations of the manufacturers whose products are involved in the roof assembly.

## X2.8 The Pre-Roofing Conference

X2.8.1 The architect, engineer or roofing designer should convene a conference before the roof system assembly work begins.

X2.8.2 This conference should be attended by the owner or representatives, the architect, the general contractor, the deck contractor, the roofing contractor, a representative of the roofing materials manufacturers, the insurance carrier, and if there is a separate mechanical contractor, he should be present also. A record should be made of the meeting, and all decisions made at the meeting should be made a part of the job record. The following items are some of the major points that should be discussed and finalized at the meeting.

X2.8.2.1 Review in detail the architect's specifications, roof plans, and all roof and flashing details. If a manufacturer's specification is specified, it should be reviewed and any deviation or difference from the architect's specification should be resolved and made part of the record. If Factory Mutual or Underwriters' Laboratories requirements are part of the specification, these requirements should be reviewed and understood and any conflicts in the FM or UL specifications and the architect's/manufacturer's specifications should be resolved. If only the architect's specifications are used with no other reference, plans should be reviewed for roof slope deck type, drainage membrane, attachment, etc. If a conflict exists between what is considered good roofing practice and the specification, all objections should be stated immediately. If they cannot be resolved, they should become part of the record. Limitations imposed by weather or other special requirements should be understood by all parties.

X2.8.2.2 Study all plans to determine whether different roof areas receive different roof systems (thickness or type of insulation, changes in roof membrane, vapor retarder, etc.).

X2.8.2.3 Establish which areas on the site will be available for use as storage area and working area.

X2.8.3 The pre-roofing conference and inspection should serve to clarify all specifications, details, application requirements, and what work should be completed before the roofing operation can begin. With the results of this meeting in writing and part of the job record, there should be a minimum of questions arising during the job operation.

## X2.9 Insurance Considerations

X2.9.1 The building owner should consult their property insurance company in order to obtain specifications and recommendations for fire rating and uplift resistance. It should be noted that the insurance recommendations may be different from those set forth in this practice.

## X2.10 Roof Consultants

X2.10.1 *Introduction*—Roofing is recognized as a complex subject, requiring more specialized knowledge than most building designers have. Specialists are available who have the knowledge and experience necessary to provide competent consulting services to architects, engineers, roofing and general contractors, manufacturers of roofing, and building owners.

X2.10.2 *Definition*—The term, "roofing specialist consultant" should mean an individual or firm of established competence having professional qualifications as a roofing consultant and who is engaged in the field of roofing technology. They may also maintain a regular force of professionals and technicians.

X2.10.3 The roofing specialist consultant should be knowledgeable in: (1) field investigations, sampling procedures, and laboratory analysis and testing; (2) design counseling and review, preparing complete contract documents (such as specifications, drawings, and details for new or remedial roofing systems); (3) design of roof decks, and observation of roof construction work for compliance with contract; and (4) specifications and details, report preparation, and life-cycle costing services for roofing systems. They should accept assignments only to the extent that they are fully qualified to carry them out to a successful conclusion, based on education, training, and experience. They may utilize services of other qualified consultants and technicians. The roofing specialist consultant should have a thorough knowledge of the conditions to which the roof will be exposed during construction, as well as during its life and protection for a building. These include construction loads, maintenance loads, design live and dead loads, wind uplift loads, and thermal loads resulting in expansion and contraction. The roofing specialist consultant should know the effect of these loads on the individual components as well as on the system as a whole; should know properties and the limiting level of the properties of the individual materials, and of the assemblies that make up the roof; should be able to apply them to the evaluation of an existing roof, or for the design of the new one; should understand the effects of temperature and moisture on roofing materials and roofing systems; should have thorough knowledge of the history of



roofing methods and materials as well as modern roof construction techniques and roofing equipment; and should possess liability insurance when required. The roofing specialist consultant should actively continue to be informed of current technology on existing roofing and roofing methods as well as new ideas, concepts, roofing materials, and methods.

X2.10.4 *Standards of Ethics*—The roofing specialist consultant’s professional conduct shall be responsible, prudent, honest, and impartial, and should strive for the highest levels of excellence that effort, training, management, and scientific methods will allow.

### X2.11 Testing Laboratories

X2.11.1 Testing laboratories range from a single person to corporations with representatives worldwide. Regardless of their size, the testing laboratory must perform accurate, unbiased investigations.

X2.11.2 See Practice E 699, which pertains to the evaluation of testing agencies.

### X2.12 Owners and Designers

X2.12.1 The building owner is increasingly concerned about the roof of the building. These concerns are largely summed up as follows:

X2.12.1.1 The built-up roof is the most vulnerable part of the building in its role as an environmental separator. As such, in the building industry, it is one of the largest building maintenance cost items.

X2.12.1.2 The damage caused to building and contents by a roof leak is often many times more costly than the cost of repairs to the roof.

X2.12.2 It is the purpose of this practice to provide guidance to the previously stated concerns. Along with these concerns, the owners must recognize their own responsibility for regular preventative maintenance. This should take the form of at least two inspections of the roof annually, one in the spring and one in the fall, to clean the drains and remove any debris that has collected, as well as to watch for developing problems. All such problems should be repaired immediately, using recognized repair methods. During the life of the roof, aging may become apparent with felts becoming exposed or alligatoring appearing on the surface. At these times, a coating may extend the life of a roof. Once the felts have become brittle, they have lost their strength, and it may be too late for preventative maintenance. The design concept included in this practice is recognized as the present state of the art in accordance with consensus among designers, manufacturers and users. It is not the intent of this practice to discourage innovation. New developments will appear from time to time to alter some of the design criteria in this practice. Designers must keep up with new developments in the field of roofing, just as they must in other areas of building design. They must acquaint themselves with properties of the materials used in roofing and also with the properties of the assemblies of these materials. They should also be acquainted with the physics of moisture and thermal transmission. Armed with this kind of information, the designer will be able to evaluate new materials or new systems that appear on the market. They will also thereby provide themselves with the knowledge required to become innovative when

faced with an unusual roofing problem. Some excellent sources of other information for the designer and building scientist are listed Section 2.

### X2.13 Fire Performance

X2.13.1 Since roof coverings are generally composed of combustible materials, most authorities require first test documentation on roof coverings, fire spread, rate of burning, fire penetration, etc. as appropriate, to ascertain that life or property is not unduly jeopardized. The insulated steel deck roof assembly requires three distinctly different fire performance documentations: exposure to external fire, exposure to internal fire, and fire endurance.

X2.13.1.1 *External Fire Exposure*—There has long been concern about conflagration resulting from rapid fire communication across roofs from building to building. Roof coverings are classified as Class A, B, or C in accordance with demonstrated ability when exposed to three levels of fire severity, with Class A being most severe and Class C being the least severe in accordance with Test Methods E 108.

X2.13.1.2 *Internal Fire Exposure*—Comprehensive, large-scale fire research, by the Factory Mutual Research Corporation in its Steel Roof Deck Approval Standard 4450, determined the limitation of the nature and quantity of combustible material at the interface of the insulation with a deck in order to prevent a self-propagating fire. A series of tests were conducted on various roof systems utilizing a 6 m (20 ft) by 30 m (100 ft) test structure with fuel-fired burners at one end, programmed to develop the standard time-temperature relationship within the first 20 ft from the burner end. An assembly utilizing a 1-in. vegetable fiberboard insulation, mechanically fastened to the roof deck with no adhesive at the deck interface, and with a built-up, gravel surface roof covering was considered to be acceptable with respect to fire spread damage.

(1) Factory Mutual Research Corporation and Underwriters’ Laboratories, Inc. have developed and calibrated small scale tests to permit comparative evaluations of roof covering assemblies for the above described.

(2) Underwriters’ Laboratories method of evaluation (as described in Subject 1256 “Outline of the Proposed Investigation for Roof Deck Construction”) established the fire spread and damage correlation to that of an insulated steel-deck roof assembly with mechanically fastened, 1-in. thick, vegetable fiberboard. These criteria are described by Underwriters’ Laboratories as fire classified.

(3) The Factory Mutual classifications are determined in their Construction Materials Calorimeter, Class I Steel Roof Deck Approval Standard 4450, and the criteria for acceptance is that the maximum rate of heat release for any 3-min period during the test duration of 30 min, shall not exceed 2330 W/min m<sup>2</sup> (410 Btu/min ft<sup>2</sup>). Those assemblies that meet the heat release criteria are designated as Class I. Metal deck roof assemblies that have failed the fire test, are designated as Class II.

X2.13.1.3 *Fire Endurance*—Fire endurance should be established where required by the responsible authorities on the basis of Test Methods E 119.

## X2.14 Mediation Services

X2.14.1 In case a problem occurs or technical assistance is required that cannot be readily resolved, an independent mediation service is available through the American Arbitration Association to architects, owners, and contractors to resolve differences of opinion on problems involving roof assemblies.

## X2.15 Moisture Evaluation

X2.15.1 Migration or penetration, or both, of moisture can be the most detrimental factor in the performance of a roof system. Moisture in built-up roofing materials has long been recognized as a major cause of roof deterioration and roof failure. Excessive moisture in the membrane causes loss of tensile strength, along with blisters and delamination. Excessive moisture in insulation causes rot organisms to flourish and also loss of thermal insulating properties. Moisture entry may be the result of membrane puncture, flashing problems, long-term accumulation of water in low nondraining regions resulting in slow penetration and leakage around drains. The obvious result is increased heating, cooling, and maintenance costs and shortened membrane life.

X2.15.2 When the entire roof system is periodically subjected to a moisture detection technique, locations of incipient moisture problems can be readily identified and plans made for correction. Detection techniques include a periodic visual inspection, based on infrared thermography, nuclear, and electrical capacitance techniques. The owners should choose the most practical procedure that meets their requirements and protects the potential performance of the building.

### X2.15.3 *Nondestructive Moisture Detection Techniques Other Than Visual:*

X2.15.3.1 *Infrared Thermography*—Temperature is used as the moisture analog. This method detects wet insulation above a set level. One method of infrared thermography utilizes a handheld camera, another uses a scanner mounted in an aircraft. Different tones or hues on a thermogram denote differences in the apparent surface temperature of all objects in view. The amount of infrared radiation emitted by a surface is not just a function of its temperature, but also of its emissivity,

the ease with which heat is radiated. Although water has a heat capacity very much greater than insulation, it is difficult for the infrared technique to detect low moisture levels, and the technique is best used at night when interference from sunlight is absent.

X2.15.3.2 *Nuclear Method*—Detection of moisture in insulation and the roofing membrane is based on detecting the back scatter of resulting slow-moving neutrons from collisions with hydrogen atoms, a component of water and bitumens, as well as other building components. The hydrogen atoms are an analog of moisture. Typically, measurements are made at points on a grid. A contour map is then produced. Adjustments of data are necessary to compensate for hydrogen containing roofing materials before usable moisture information is obtained. Once the adjustments to the readings have been made, it is possible to determine the area of wet insulation and roofing.

X2.15.3.3 *Capacitance Method*—This method measures changes in the dielectrical properties in the roofing system as they change with moisture content. The apparent change in dielectric constant is the moisture analog for the capacitance system. Materials used in a built-up roof have low and quite uniform dielectric constants, roughly in the range from 2 to 3. Water, on the other hand, has very high dielectric constant of about 81. As a result, even very small quantities of moisture have a great effect on the dielectric properties of the roofing system. This is purported by a franchisor to be the only system that can differentiate moisture in both the membrane and insulation, and to be less likely affected by the substrate, although metals can short circuit the electrical path. With this method, measurements are made at points on a grid which may be made as rapidly as the reading can be taken. A contour map is thus produced.

X2.15.4 All three of the foregoing methods require actual field samples to establish and verify actual moisture content by gravimetric determination.

X2.15.5 Detection of moisture and the location of the source of roof leaks are separate. Moisture evaluation may help to find a leak but only if the leak results in a wet component of the roofing system.

*ASTM International takes no position respecting the validity of any patent rights asserted in connection with any item mentioned in this standard. Users of this standard are expressly advised that determination of the validity of any such patent rights, and the risk of infringement of such rights, are entirely their own responsibility.*

*This standard is subject to revision at any time by the responsible technical committee and must be reviewed every five years and if not revised, either reapproved or withdrawn. Your comments are invited either for revision of this standard or for additional standards and should be addressed to ASTM International Headquarters. Your comments will receive careful consideration at a meeting of the responsible technical committee, which you may attend. If you feel that your comments have not received a fair hearing you should make your views known to the ASTM Committee on Standards, at the address shown below.*

*This standard is copyrighted by ASTM International, 100 Barr Harbor Drive, PO Box C700, West Conshohocken, PA 19428-2959, United States. Individual reprints (single or multiple copies) of this standard may be obtained by contacting ASTM at the above address or at 610-832-9585 (phone), 610-832-9555 (fax), or service@astm.org (e-mail); or through the ASTM website (www.astm.org).*