



## Standard Specification for Rigid Foam for Use in Structural Sandwich Panel Cores<sup>1</sup>

This standard is issued under the fixed designation E 1730; the number immediately following the designation indicates the year of original adoption or, in the case of revision, the year of last revision. A number in parentheses indicates the year of last reappraisal. A superscript epsilon ( $\epsilon$ ) indicates an editorial change since the last revision or reappraisal.

### 1. Scope

1.1 This specification covers rigid, closed cell, polyurethane and polyisocyanurate thermal insulation for sandwich panels used in shelter construction for exposure to ambient temperatures of  $-25^{\circ}$  to  $160^{\circ}\text{F}$  ( $-32^{\circ}$  to  $71^{\circ}\text{C}$ ). Painted surfaces of shelters in actual field use reach temperatures of  $200^{\circ}\text{F}$  ( $93^{\circ}\text{C}$ ). The materials in this specification must be capable of withstanding processing, (laminating) temperatures of  $110^{\circ}\text{C}$  ( $230^{\circ}\text{F}$ ).

1.2 The values stated in either inch-pound or SI units are to be regarded separately as the standard. The values given in parentheses are for information only.

1.3 The following precautionary caveat pertains only to the test method portion, Section 12, of this specification: *This standard does not purport to address all of the safety concerns, if any, associated with its use. It is the responsibility of the user of this standard to establish appropriate safety and health practices and determine the applicability of regulatory limitations prior to use.*

### 2. Referenced Documents

#### 2.1 ASTM Standards:

- C 165 Test Method for Measuring Compressive Properties of Thermal Insulations<sup>2</sup>
- C 168 Terminology Relating to Thermal Insulating Materials<sup>2</sup>
- C 177 Test Method for Steady-State Heat Flux Measurements and Thermal Transmission Properties by Means of the Guarded Hot Plate Apparatus<sup>2</sup>
- C 273 Test Method for Shear Properties in Flatwise Plane of Flat Sandwich Constructions or Sandwich Cores<sup>3</sup>
- C 366 Test Methods for Measurement of Thickness of Sandwich Cores<sup>3</sup>
- C 390 Criteria for Sampling and Acceptance of Preformed Thermal Insulation Lots<sup>2</sup>
- C 518 Test Method for Steady-State Heat Flux Measurements and Thermal Transmission Properties by Means of the Heat Flow Meter Apparatus<sup>2</sup>

<sup>1</sup> This specification is under the jurisdiction of ASTM Committee E-6 on Performance of Buildings and is under the direct responsibility of Subcommittee E06.53 on Materials and Processes for Durable Rigidwall Relocatable Structures. Current edition approved Oct. 10, 1999. Published November 1999. Originally published as E 1730-95. Last previous edition E 1730-95.

<sup>2</sup> Annual Book of ASTM Standards, Vol 04.06.

<sup>3</sup> Annual Book of ASTM Standards, Vol 15.03.

- C 550 Practice for Measuring Trueness and Squareness of Rigid Block Thermal Insulation<sup>2</sup>
- D 883 Terminology Relating to Plastics<sup>4</sup>
- D 1621 Test Method for Compressive Properties of Rigid Cellular Plastics<sup>4</sup>
- D 1622 Test Method for Apparent Density of Rigid Cellular Plastics<sup>4</sup>
- D 1623 Test Method for Tensile and Tensile Adhesion Properties of Rigid Cellular Plastics<sup>4</sup>
- D 2126 Test Method for Response of Rigid Cellular Plastics to Thermal and Humid Aging<sup>4</sup>
- D 2856 Test Method for Open Cell Content of Rigid Cellular Plastics by the Air Pycnometer<sup>5</sup>
- E 864 Practice for Surface Preparation of Aluminum Alloys to Be Adhesively Bonded in Honeycomb Shelter Panels<sup>6</sup>
- F 501 Test Method for Aerospace Materials Response to Flame with Vertical Test Specimen (for Aerospace Vehicles Standard Conditions)<sup>7</sup>
- 2.2 Code of Federal Regulations Aeronautics and Space: 14 CFR 25.853 (Federal Air Regulation 25.853) Compartment Interior (Amend. 25-72)<sup>8</sup>
- 2.3 Federal Standard:
  - QQ-A-25011 Aluminum Alloy 6061-T6 Plate and Sheet<sup>9</sup>
  - QQ-A-260/11 Aluminum Alloy 6081, Plate and Sheet<sup>9</sup>
- 2.4 Military Standards:
  - MIL STD 105 Sampling Procedures and Tables for Inspection by Attributes<sup>9</sup>

### 3. Terminology

3.1 *Definitions*—The terms used in this specification are defined in Terminologies C 168 and D 883.

### 4. Classification

4.1 The unfaced foam thermal insulation boards covered by this specification are classified as follows:

- 4.1.1 *Type 1*—Nominal density:  $32\text{ kg/m}^3$  ( $2.0\text{ lb/ft}^3$ ).
- 4.1.2 *Type 2*—Nominal density:  $48\text{ kg/m}^3$  ( $3.0\text{ lb/ft}^3$ ).
- 4.1.3 *Type 3*—Nominal density:  $64\text{ kg/m}^3$  ( $4.0\text{ lb/ft}^3$ ).

<sup>4</sup> Annual Book of ASTM Standards, Vol 08.01.

<sup>5</sup> Annual Book of ASTM Standards, Vol 08.02.

<sup>6</sup> Annual Book of ASTM Standards, Vol 04.11.

<sup>7</sup> Discontinued: see 1998 Annual Book of ASTM Standards, Vol 04.07.

<sup>8</sup> Available from Superintendent of Documents, U.S. Government Printing Office, Washington, DC 20402.

<sup>9</sup> Available from Standardization Documents Order Desk, Bldg. 4 Section D, 700 Robbins Ave., Philadelphia, PA 19111-5094, Attn: NPODS.

4.1.4 *Type 4*—Nominal density: 192 kg/m<sup>3</sup> (12.0 lb/ft<sup>3</sup>).

## 5. Ordering Information

5.1 Orders for materials purchased under this specification shall include the following:

- 5.1.1 Designation of this specification,
- 5.1.2 Product name and type, or both,
- 5.1.3 Dimensions and tolerances,
- 5.1.4 Impact resistance test specimen preparation,
- 5.1.5 Material marking requirements, and
- 5.1.6 Packaging requirements.

## 6. Foam

6.1 The morphology of the insulation shall consist of a multitude of individual cells of uniform size and dimension, essentially closed off from each other, homogeneous throughout, free of voids, accumulations of unexpanded material, foreign inclusions, or seams (see Table 1).

## 7. Dimensions and Tolerances

7.1 The dimensions, squareness, and tolerances shall be specified by the purchaser.

## 8. Qualification

8.1 When required by the purchaser, materials supplied under this specification must be tested for and meet the properties listed in Table 2. Having a qualified product does not obviate the supplier from continued, on-going product compliance with all requirements to this specification.

8.2 In addition to meeting the requirements of the tests stipulated in Table 2 as manufactured, the compressive, tensile, and shear properties must also meet these requirements after having been preconditioned for 4 h at 110°C (230°F), and allowed to equilibrate in accordance with 11.2.

8.3 Unless otherwise specified by the purchaser, qualified materials remain qualified as long as there are no changes in product formulation, critical raw materials, that is, isocyanates and polyols, basic methods of manufacture, or plant location.

## 9. Acceptance

9.1 *Lot Size for Acceptance Testing*—For the purpose of acceptance testing a lot is defined as a single, identifiable, production run using raw materials from a single batch.

9.2 *Acceptance Testing (Physical Properties)*—A representative sample shall be selected from each foam lot and tested for the following physical properties:

**TABLE 1 Classification of Characteristics**

Characteristic	Major		Method of Inspection
	Major	Minor	
Length, width, and thickness	X	...	9.4.3
Edge squareness	X	...	9.4.3
Holes through board exceeding 40 mm <sup>2</sup> for each 92900 mm <sup>2</sup> (0.0625 in. <sup>2</sup> for each square foot) of area	X	...	9.4.2
Crushed foam	X	...	9.4.2
Voids larger than 40 mm (0.0625 in. <sup>2</sup> )	X	...	9.4.2
Unexpanded material	...	X	9.4.2
Foreign inclusions	...	X	9.4.2
Contaminants	...	X	9.4.2
Seams	X	...	9.4.5

Property	Requirement	Method
Density	Table 2	12.1
Compressive strength	Table 2	12.3
Shear strength	Table 2	12.5
Flame resistance	Table 2	12.8

### 9.3 Sampling for Acceptance (Examination):

9.3.1 Samples for quality conformance examination shall be selected in accordance with Inspection Level II of MIL STD 105.

9.3.2 When the conditions for reduced inspection specified in MIL-STD-105 have been complied with, a reduced sampling in lieu of full sampling shall be instituted. Sampling for reduced inspection shall be in accordance with Criteria C 390 (Inspection Level S-2 of MIL STD 105).

### 9.4 Examination:

9.4.1 Samples selected in accordance with 9.3 shall be examined for characteristics listed in Table 1.

9.4.2 Visual examination shall consist of scanning for surface characteristics.

9.4.3 Dimensional measurements shall be made with calipers, rules, and tape rules as appropriate to the specified tolerances. In cases of dispute or when specifically invoked by the purchaser, the methodology and procedures of Method C 336 or Practice C 550 shall be utilized.

9.4.4 The Acceptable Quality Level (AQL) for major characteristics shall be 1.0 % and for minor characteristics shall be 2.5 %.

9.4.5 Seams (see Table 1) are defined as: a plane of undermixed material, or a fold which developed within the rising foam mass that reduces the tensile strength of the foam. When viewed normal to a cut sheet, a seam appears as a line on the foam surface. This condition must be differentiated from simple discoloration (arising from the same causes but not as pronounced) that have no appreciable effect on foam strength. This condition shall be evaluated by taking a sample, (not to exceed 51 mm (2 in.) thick from the sheet and bending it over a 305 mm (12 in.) cylinder to failure. If the failure plane follows the discontinuity then the discontinuity shall be considered a seam.

## 10. Physical Property Requirements

10.1 The rigid, cellular polyurethane or polyisocyanurate foam shall have limiting property values as shown in Table 2.

## 11. Test Preconditioning

11.1 A period of at least 72 h must elapse from the time of foam manufacture until the cutting of any test specimens.

11.2 Unless otherwise specified, by the purchaser, the test specimens shall be conditioned at 24 ± 2°C (75 ± 9°F) and at relative humidity of less than 60 % for at least 12 h prior to testing.

## 12. Test Methods

12.1 *Density*—Determine the density in accordance with Test Method D 1622.

12.2 *Thermal Conductivity*—Determine the thermal conductivity in accordance with Test Method C 177 or Test Method C 518 at mean temperatures of 5°, 24°, and 52°C (41°, 75°, 120°F) after conditioning for 7 ± 1 days at 24 ± 2°C (75

**TABLE 2 Physical and Mechanical Properties**

Requirement Procedure	Type 1	Type 2	Type 3	Type 4	Paragraph
Density, kg/m <sup>3</sup> (lb/ft <sup>3</sup> ), max	38.4 (2.4)	56.1 (3.5)	72 (4.5)	192 (13)	12.1
Thermal conductivity, W/m-K (Btu-in./hr- <sup>2</sup> ·°F), max					12.2
at approximately 5°C (41°F) mean	0.036 (0.250)	0.037 (0.257)	0.037 (0.257)	not required	
at approximately 24°C (79°F) mean	0.036 (0.250)	0.037 (0.257)	0.037 (0.257)	not required	
at approximately 52°C (120°F) mean	0.036 (0.250)	0.037 (0.257)	0.037 (0.257)	not required	
Compressive strength at 10 % deflection or at yield, kPa (psi), min	137.9 (20)	275.8 (40)	448.2 (65)	2758 (400)	12.3
Tensile strength, kPa (psi), min	206.8 (30)	344.7 (50)	517.1 (75)	1896 (275)	12.4
Shear strength, kPa (psi), min	172.4 (25)	241.2 (35)	275.8 (40)	1034 (150)	12.5
Closed cell (%), min	95	95	95	95	12.6
Dimensional stability					
Linear Δ%	±1.5	±1.5	±1.5	±1.5	12.7
Volumetric Δ%	±2.5	±2.5	±2.5	±2.5	
Flame resistance					
Extinguish time: max, s	15	15	15	15	12.8
Burn distance: mm (in.), max	152 (6)	152 (6)	152 (6)	152 (6)	
Impact resistance, paragraph	12.9	12.9	12.9	12.9	12.9.1

± 3°F) and less than 60 % relative humidity from time of manufacture. The heat flow is to be measured parallel to the rise of the foam. Requirements for thermal conductivity are given in Table 2.

**12.3 Compressive Strength**—Determine the compressive strength in accordance with Procedure A of Test Method D 1621, or by Test Method C 165. The compressive force is to be applied parallel to the rise direction of the foam.

**12.4 Tensile Strength**—Determine the tensile strength in accordance with Test Method D 1623. The tensile force is to be applied parallel to the rise direction of the foam.

**12.5 Shear Strength**—Determine the shear strength in accordance with Test Method C 273. Apply the shear force perpendicular to the rise direction of the foam. Specimen thickness shall be 13 mm (0.5 in.).

**12.6 Closed Cell**—Determine the percent closed cell in accordance with Procedure A or B of Test Method D 2856.

**12.7 Dimensional Stability**—Determine the dimensional stability in accordance with Test Method D 2126, at approximately 70 ± 2°C (158 ± 4°F) and ambient humidity. The test duration shall be 836 h (two weeks).

**12.8 Flame Resistance**—Determine the flame resistance in accordance with Test Method F 501 using a flame application time of 60 s. Extinguishment time and burn distance requirements are those used for compartment interiors on transport category airplanes: FAR 25.853 App. F Part-1(a)(1)(ii). Report the average extinguishment time and burn distance of three determinations.

**NOTE 1—Precaution:** This test should be used to measure and describe the properties of materials, products, or assemblies in response to heat and flame under controlled laboratory conditions and should not be used to describe or appraise the fire hazard or fire risk of materials, products, or assemblies under actual fire conditions. However, results of this test may be used as elements of a fire risk assessment that takes into account all of the factors that are pertinent to an assessment of the fire hazard of a particular end use.

#### 12.9 Impact Resistance:

**12.9.1 Specimen Preparation**—The foam specimen shall be 610 ± 1.6 mm (24.0 ± 0.082 in.) long by 610 ± 1.6 mm wide by 50 by 0.4 mm (2.0 ± 0.015 in.) thick. Bond each 610 mm face of the foam specimen to a 0.8 mm (0.032 in.) thick 6061-T6 aluminum sheet, (QQ-A-250/11). Cleaning, adhesive,

and bonding method will be as specified or approved by the customer (see 5.1.4).

**12.9.2 Testing**—Determine impact resistance as follows: Drop a 31.7 kg (70 lb) steel cylinder 3 in. in diameter and hemispherical at one end vertically 406 mm (16 in.) for Type 1 foam and 762 mm (30 in.) for Types 2, 3, and 4 foams, so that the hemispherical end of the weight strikes the center of the outer skin of the specimen on a horizontal plane. The cylinder shall not be permitted to re-impact the specimen after the first impact. Support the specimen along its four edges by a framework backed by concrete. The frame shall be made of four pieces of 2 by 4 (nominal) lumber, rigidly bolted together to form a square 610 mm (24 in.) on a side (outside dimension), 100 mm (4 in. nominal) high, so that the frame rests on the 50 mm (2 in. nominal) faces. The panel specimen shall have the four edge surfaces bound with a 25 mm (1 in.) flange channel frame of skin material attached through flanges by 1/8 in. blind rivets on 100 mm (4 in.) centers and shall be bolted to the frame with a minimum of two 1/4 in. diameter bolts per edge (see Fig. 1). Tighten the bolts against the specimen and then back off so that there is a nominal gap of 0.25 mm (0.010 in.) between the bolt head and the panel.

**12.9.3 Evaluation**—After the test, cross section the specimen through the impact area and examine. Impact shall not result in rupture to either skin. No delamination between skins and core or crushing of core is allowed outside a 3 in. radius from the center of the impact.

## 13. Packaging

13.1 Cleaning, preservation, marking, and packaging shall be in accordance with the applicable packaging standard or packaging data sheet for the level of protection specified by the procuring agency (see 5.1.6, section 5.1.7).

## 14. Keywords

14.1 impact resistance; polyisocyanurate foam; polyurethane foam; relocatable shelters; rigid foam; sandwich panel; sandwich panel core; thermal insulation

**ASTM E 1730**

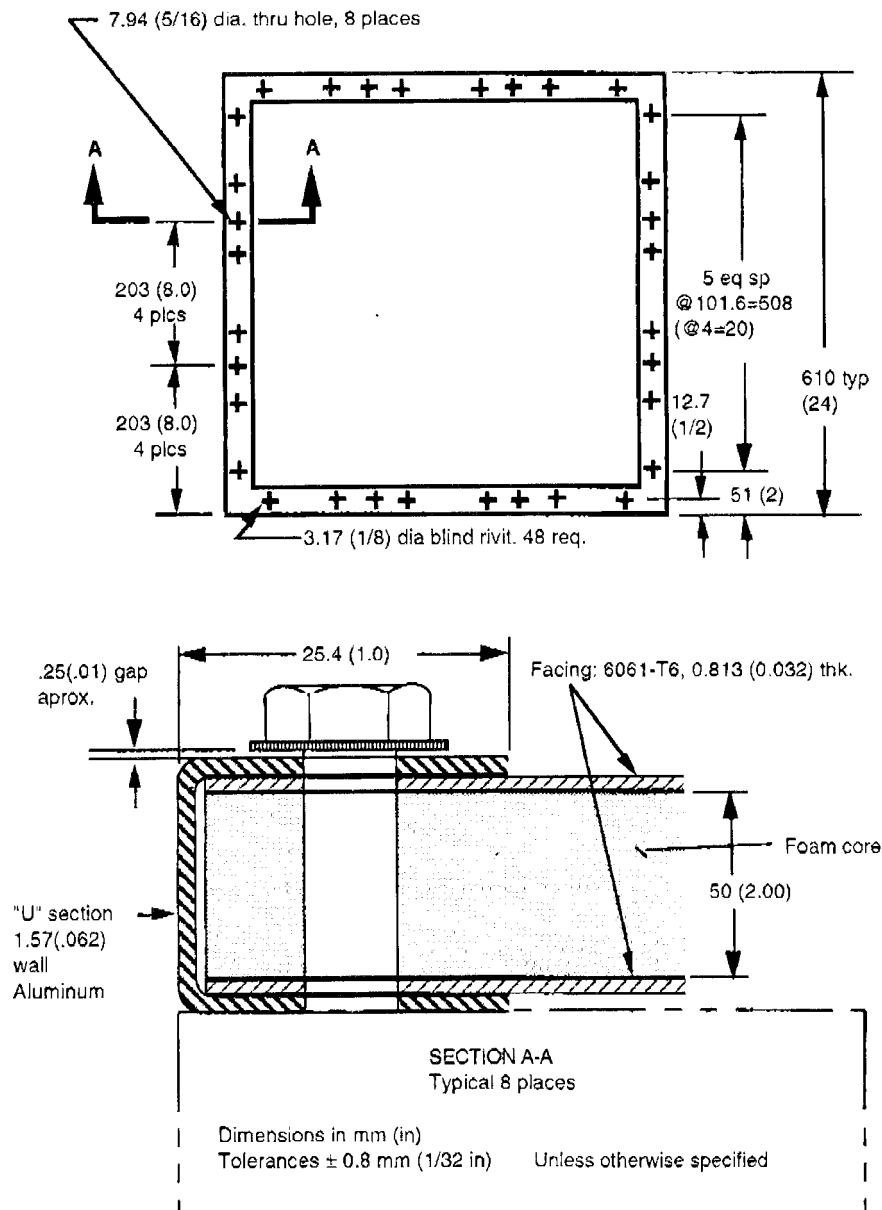

**FIG. 1 Panel Specimen for Testing**

The American Society for Testing and Materials takes no position respecting the validity of any patent rights asserted in connection with any item mentioned in this standard. Users of this standard are expressly advised that determination of the validity of any such patent rights, and the risk of infringement of such rights, are entirely their own responsibility.

This standard is subject to revision at any time by the responsible technical committee and must be reviewed every five years and if not revised, either reapproved or withdrawn. Your comments are invited either for revision of this standard or for additional standards and should be addressed to ASTM Headquarters. Your comments will receive careful consideration at a meeting of the responsible technical committee, which you may attend. If you feel that your comments have not received a fair hearing you should make your views known to the ASTM Committee on Standards, 100 Barr Harbor Drive, West Conshohocken, PA 19428.

This standard is copyrighted by ASTM, 100 Barr Harbor Drive, West Conshohocken, PA 19428-2959, United States. Individual reprints (single or multiple copies) of this standard may be obtained by contacting ASTM at the above address or at 610-832-9585 (phone), 610-832-9555 (fax), or [service@astm.org](mailto:service@astm.org) (e-mail); or through the ASTM website (<http://www.astm.org>).