



Specification for Engineering and Design Criteria for Rigid Wall Relocatable Structures¹

This standard is issued under the fixed designation E 1925; the number immediately following the designation indicates the year of original adoption or, in the case of revision, the year of last revision. A number in parentheses indicates the year of last reapproval. A superscript epsilon (ϵ) indicates an editorial change since the last revision or reapproval.

1. Scope

1.1 This specification covers engineering and design criteria required for the development of rigid wall relocatable structures (RWRS) and shall be applied to the design of expandable and nonexpandable RWRSs. This specification applies to present engineering and design requirements for effective RWRSs that are operable in a variety of environments without degradation and are capable of all specified transport modes. This specification shall be applied to the design of expandable and nonexpandable RWRSs. This specification is a conversion of a military standard that was approved by all departments and agencies of the Department of Defense.

1.2 The values stated in inch-pound units are to be regarded as the standard. The values given in parenthesis are for information only.

1.3 The following safety hazards caveat pertains only to the test required portion, Section 10, of this specification. *This specification does not purport to address all of the safety concerns, if any, associated with its use. It is the responsibility of the user of this specification to establish appropriate safety and health practices and determine the applicability of regulatory limitations prior to use.*

2. Referenced Documents

2.1 ASTM Standards:

E 1851 Test Method for Electromagnetic Shielding Effectiveness of Durable Rigid Wall Relocatable Structures²

G 21 Practice for Determining Resistance of Synthetic Polymeric Materials to Fungi³

2.2 ISO Standards:

ISO 668-1995, Series 1 Freight Containers - Classification, Dimensions and Ratings, 5th Edition⁴

ISO 1161-1990, Series 1 Freight Containers - Corner Fittings⁴

ISO 1496-1, Series 1 Freight Containers Specification and Testing Document - Part 1, 1993⁴

¹ This specification is under the jurisdiction of ASTM Committee E-6 on Performance of Buildings and is under the direct responsibility of Subcommittee E06.53 on Materials and Processes for Durable Rigid Wall Relocatable Structures.

Current edition approved Oct. 10, 1999. Published December 1999. Originally published as E 1925 – 97. Last previous edition E 1925 – 97.

² Annual Book of ASTM Standards, Vol 04.11.

³ Annual Book of ASTM Standards, Vol 14.02.

⁴ Available from American National Standards Institute, W 42nd St., 13th Floor, New York, NY 10036.

ISO 1496-2, Series 1 Freight Containers Specification and Testing Document - Part 2, 1993⁴

2.3 Military Standards:

MIL-STD-1472D, Notice 3, Human Engineering Design Criteria for Military Systems, Equipment and Facilities⁵

MIL-M-8090F, General Requirements for Towed Aerospace Ground Equipment Mobility⁵

MIL-F-14072D, Finishes for Ground Electronic Equipment⁵

MIL-C-22992E, Amend 5, Connector, Plugs and Receptacles, Electrical, Waterproof, Quick Disconnect, Heavy Duty Type General Specification for ⁵

MIL-STD-810E, Notice 3, Environmental Test Methods and Engineering Guidelines⁵

MIL-STD-1791, Notice 1, Designing for Internal Aerial Delivery in Fixed Wing Aircraft⁵

3. Terminology

3.1 Definitions:

3.1.1 *degradation*—damage by the weakening or loss of some property, quality, or capability.

3.1.2 *delamination*—separation into constituent layers.

3.1.3 *galvanic corrosion*—the corrosion of metallic objects in the presence of moisture, caused by electrolytic action.

3.1.4 *special tools*—tools other than common hand tools or those designed specifically for use with a delivered product.

4. Materials and Manufacture

4.1 *Materials and Workmanship*—All materials and workmanship shall be in accordance with good commercial practice. All materials shall be recovered materials to the maximum extent possible consistent with quality and performance. All materials shall be free of defects that would affect the performance or maintainability of individual components or the overall assembly adversely.

4.2 *Dissimilar Materials*—The intimate contact of dissimilar materials, which can be expected to cause galvanic corrosion, shall be prevented. When such contact cannot be prevented, an insulating material shall be provided to minimize the corrosive effect.

4.3 *Corrosion*—All RWRS components shall be adequately

⁵ Available from Standardization Documents Order Desk, Bldg. 4, Section D, 700 Robbins Ave., Philadelphia, PA 19111-5094, Attn: NPODS.

protected from corrosion per MIL-F-14072D. The use of dissimilar metal combinations shall be avoided whenever possible. The selection of permissible couples shall be in accordance with the compatible couples table of MIL-F-14072D. If, due to special conditions of service or design, the contractor considers that finishes, processes, or materials other than those specified herein are necessary or more suitable, such finishes, processes, or materials may be used.

4.4 *Toxicity*—The materials (in their cured state) used shall cause no skin irritations or other injury to personnel handling the material during transportation, operation, or maintenance of the equipment. Exposure of personnel to toxic substances shall not be in excess of the threshold values contained in the American Conference of Government Industrial Hygienists Threshold Limit Values.

5. General Requirements

5.1 *Objectives*—The RWRS shall be designed and built to withstand a variety of environments while providing an effective and reliable facility for system equipment. The design shall also be directed toward minimizing the man-hours required to strike or erect RWRSs using common hand tools.

5.2 *Standardization*—The design and engineering requirements specified herein are designed to encourage standardization of RWRSs. Existing performance and test criteria have been used to the maximum extent possible.

5.3 *Simplicity of Design*—The RWRS shall represent the simplest design consistent with functional and performance requirements, expected service conditions, and structure life.

5.4 *RWRS Life, Reliability and Maintainability*—The design life for a typical structure shall be 15 years.

6. Physical Properties Requirements

6.1 *Interchangeability of Parts*—Like units, assemblies, sub-assemblies, and replaceable parts shall be physically and functionally interchangeable without modification of either such items or the unit. Demonstration of the interchangeability of selected panels and hardware shall be conducted.

6.2 *Special Tools*—There shall be no special tools or equipment required to erect or strike RWRSs. Standard hand tools may be provided as required.

6.3 *Physical Security*—A means shall be provided to secure all openings, folding panels, and removable components in order to prevent unauthorized entry.

6.4 *Lighting Provision*—If lighting is installed as part of the basic RWRS, all RWRS tests shall be conducted with such provisions installed.

6.5 *Electrical Grounding*—The RWRS electrical system shall be grounded through electrical input cable back to the power source ground.

6.6 *Input-Output Panels and Openings*—All RWRS tests shall be conducted with the panels and openings installed if input-output panels and openings are installed as part of the basic RWRS.

6.7 *Electrical Power Connector*—When an electrical power connector is provided as part of the basic design of a nonexpandable or expandable RWRS, that connector shall be a class L connector in accordance with MIL-C-22992E.

6.8 *Lightning Protection*—A separate grounding system for

lightning protection shall be designed for the RWRS.

6.9 *Human Engineering and Safety*—The provisions of MIL-STD-1472D applicable to RWRSs shall be implemented.

7. Performance Requirements

7.1 *Air Transportability*—The air transportability of all RWRS shall comply with the guidelines of MIL-STD-1791. See 10.2 for verification test.

7.2 *Ground Mobility*—The RWRS shall be capable of withstanding the shocks and vibrations induced by ground transport equipment over the mobility courses described for Type V mobility in MIL-M-8090F. See 10.3 for verification test.

7.3 *Rail Transportability*—The RWRS shall be capable of withstanding the shocks induced by rail transport without damage. See 10.4 for verification test.

7.4 *Forklift Handling*—The RWRS shall be capable of withstanding the stresses of forklift movements or shall be marked “DO NOT FORKLIFT.” See 10.5 for verification test.

7.5 *Erecting and Striking*—Erecting and striking expandable and nonexpandable RWRS shall be accomplished within two man-hours per 150 square feet (ft²) (14 m²) of floor space. The RWRS shall be capable of being erected and struck on a surface that has up to a 24-in. (610-mm) differential in grade to the diagonal dimension of the RWRS floor. See 10.6 for verification test.

7.6 *Weather Seals*—Weather seals shall be designed to be an integral part of the RWRS and shall be designed to be readily replaceable by user in the field without the use of special tools. This requirement shall be verified by demonstration.

7.7 *Airtightness*—The RWRS shall not permit air leakage in either the shipping or operational configuration, as specified in 10.7 and 10.8 verification test.

7.8 *Blackout*—The RWRS shall not permit light emission with the doors closed, in an operational mode. See 10.9 for verification test.

7.9 *Ice*—The RWRS design shall not permit water accumulation in pockets, creases, fissures, etc., which could cause structural damage upon freezing. The operation of moveable RWRS components shall not be impaired unduly by the formation of ice anywhere on the RWRS structure. This requirement shall be validated by analysis.

7.10 *Wind Velocities (Load)*—When tied down, the RWRS shall withstand winds up to 100 mph (160 km/h) steady state, with gusts up to 120 mph (190 km/h). This requirement shall be validated by analysis.

7.11 *Altitude (Low Pressure)*—The RWRS shall use devices permitting air passage and allowing pressure equalization to preclude damage to the RWRS. At least a total of 12 in.² of vent area for each 10 ft length (2500 mm² of vent area for each metre length), or fraction thereof, or RWRS shall be provided. This requirement shall be verified by analysis.

7.12 *Humidity Resistance*—The RWRS shall withstand daily exposure of up to 97 % relative humidity for 20 h and exposure of 100 % relative humidity (with condensation) for 4 h. See 10.10 for verification test.

7.13 *Marine Corrosion Resistance*—The RWRS shall be fully serviceable when exposed to a salt environment as specified in 10.11. All hardware including fasteners, jacks, and

seals shall show no evidence of corrosion or degradation following 96 h of exposure to this simulated environment. See 10.11 for verification test.

7.14 Temperature Range—In storage, the RWRSs shall be capable of withstanding exposure to temperatures of -70 to 160°F (-57 to 71°C). In transit, the RWRSs shall be capable of withstanding exposure to temperatures of -65 to 160°F (-54 to 71°C) with personnel access at low end of range. Operational temperature of RWRS shall be -40 to 120°F (-40 to 49°C). See 10.12 for verification test.

7.15 Solar Loads Assembled RWRS—The RWRS shall withstand a simulated solar load outer skin temperature of 205°F (96°C) while internal temperature is maintained at 85°F (29°C). See 10.13 for verification test.

7.16 Temperature Shock—RWRS panels, windows, and other components shall withstand a temperature shock from 160 to -70°F (71 to -57°C) without separation, delamination cracks, or degradation. See 10.14 for verification test.

7.17 Heat Transfer—The RWRS shall have an overall heat transfer coefficient less than or equal to 0.35 $\text{Btu}/(\text{h}\cdot\text{ft}^2\cdot^{\circ}\text{F})$ ($2.0\text{W}/(\text{m}^2\cdot^{\circ}\text{K})$), in the operational configuration. Heat transfer coefficient for nonexpandable shelters shall be less than or equal to 0.35 $\text{Btu}/\text{hr}\cdot\text{ft}^2\cdot^{\circ}\text{F}$ in the transport configuration. See 10.15 for verification test.

7.18 Blowing Sand—The external moving parts of the RWRS in transport or operational mode shall be designed to resist the effects of blowing sand. External moving parts shall be designed to operate and withstand particle concentrations of 1.32×10^{-4} lb/ft^3 (2.19 g/m^3) with a wind velocity of 1750 ± 250 ft/min (8.9 ± 1.3 m/sec) without degradation. Such particles shall range in size from 6×10^{-3} in. (150 μm) to 4×10^{-2} in. (1000 μm). Relative humidity shall be less than 23 %. See 10.16 for verification test.

7.19 Sunshine (Ultraviolet Effects)—Ultraviolet effects shall neither significantly degrade nor affect the serviceability of RWRS components or materials for the service life of the RWRS. See 10.17 for verification test.

7.20 Fire Resistance—The RWRS shall be designed to be fire resistant. See 10.18 for verification test.

7.21 Fungus—There shall be no degradation of RWRS components due to fungus growth. Materials shall be selected to minimize fungal growth. See 10.19 for verification test.

7.22 RWRS Squareness—The RWRS must be squared so that in any two intersecting fixed RWRS wall, floor, or roof panels, the inside panel surface in one panel shall be mutually perpendicular to the inside surface of the adjacent panel within $1/16$ in. (2 mm) when measured with a 36-in. (900 mm) square whose two edges are perpendicular to each other within 0.005 in. (0.1 mm). This requirement does not apply to curved wall shelter designs. Outside and inside skin temperatures shall be within 5°F (3°C) of the same temperature when this is verified. See 10.20 for verification test.

7.23 Panel Flatness—Panel surfaces shall not be cupped or bowed in excess of 0.125 in. (3 mm) when measured with a 48-in. (1300 -mm) long straight edge. Outside and inside skin temperatures shall be within 5°F (3°C) of the same temperature when this is verified. This requirement does not apply to curved wall shelter designs. See 10.21 for verification test.

7.24 Roof Loads—The roof assembly of the RWRS shall withstand a snow load of 40 lb/ft^2 (200 kg/m^2) and a personnel load of 660 lb (300 kg) static over 2 ft^2 (0.2 m^2). See 10.22 for verification test.

7.25 Floor Loads—The RWRS floor shall be capable of supporting a uniform load of 65 lb/ft^2 (320 kg/m^2). The RWRS floor shall be capable of supporting a concentrated load of $2,000$ lb (900 kg) over a 4 - ft^2 (0.4 - m^2) area at the center of the floor. The floor shall also be capable of supporting a point load of 125 lb over a 1 in. square area (57 kg over a 650 - mm^2 area). The loads shall not cause any permanent deformation of the floors or cause any deflection that interferes with proper RWRS operation. See 10.23 for verification test.

7.26 Door Loads—Doors shall be tested to withstand the following loads without deformation or impairment of function. These requirements are for vertically hinged doors. See 10.24 for verification test.

7.26.1 Static Door (Hinge) Load—The doors, frames, and hardware shall be capable of supporting 200 lb (90 kg) applied to the door at the edge opposite the hinge pivot line with the door open to approximately 90 degrees. See 10.24.1 for verification test.

7.26.2 Wind Gust Door (Stop) Load—The door frames and hardware shall withstand a wind gust of 60 mph (100 km/h) in any direction when the door is secured in its open position(s) by its door stop device(s). See 10.24.2 for verification test.

7.27 Panel Attachment Points—Panel attachment points shall have a minimum torque of 100 in.-lb and a minimum pull-out resistance (tension) of $2,000$ lb (900 kg) for panel thickness equal to or greater than 2 in. (50 mm) and $1,000$ lb (450 kg) for panel thickness under 2 in. (50 mm). Panel attachment points of less than $1/4$ in. (6 mm) thread size shall withstand a minimum torque of 100 in.-lb (11 Nm) and shall have a minimum pullout strength of 800 lb (360 kg). See 10.25 for verification test.

7.28 Leveling Device—All RWRSs shall have leveling capabilities of at least 24 in. (610 mm) over uneven terrain, without the use of shims. See 10.26 for verification test.

7.29 Lifting and Towing Eye Strength—All lifting and towing eyes shall withstand a tensile load of 2.26 times the gross weight of the RWRS. See 10.27 for verification test.

7.30 Towing and Dragging (for RWRSs with Skids)—The RWRS with attached skids shall be capable of withstanding a towing and dragging force applied to the plane of the skid attachment equal to one-half the RWRS gross weight without damage to any part of the RWRS, skid assemblies, or skid mounting brackets. See 10.28 for verification test.

7.31 Drop Shock (All RWRS without skids)—RWRSs without skids shall be capable of withstanding flat and rotational drops of 6 in. (150 mm) onto concrete. There shall be no permanent deformation, buckling, delamination, sealer separation, or structural failures of any part of the RWRS after each test, and the doors and covers shall open and close to their full extent without binding. See 10.29 for verification test.

7.32 Drop Shock (RWRS with skids)—RWRS with shock attenuating skids shall be capable of withstanding flat and rotational drops of 18 in. (460 mm) onto concrete. There shall be no permanent deformation, buckling, delamination, sealer

separation, or structural failures of any part of the RWRS after each test, and the doors and covers shall open and close to their full extent without binding. See 10.30 for verification test.

7.33 *Panel Impact*—All floor and roof shelter panels shall withstand a blow from a 70 lb (30 kg) steel cylinder as specified in 10.31. See 10.31 for verification test.

7.34 *EMI Provisions*—RWRSs requiring electromagnetic interference (EMI) shielding shall provide a minimum attenuation of radiated and induced EMI fields as shown in Fig. 1 within the frequency range of 100 kHz to 10 GHz. See 10.32 for verification test.

7.35 *Watertightness*—The RWRS, including panels and louvers, shall be made watertight without the use of additional external sealing, caulking, taping, etc. See 10.33 for verification test.

7.36 *Lift Test*—The RWRS shall incur no structural damage when subjected to a 3.2-G lift test. See 10.34 for verification test.

7.37 *ISO RWRS Compatibility Requirements*—RWRS designated ISO shelters shall meet the requirements for the following: all modes of transport (marine, highway, rail, and fixed and rotary wing aircraft), stacking requirements of marine modes, and dimensional requirements. They shall be provided with four forklift pockets. ISO standard payload ratings shall not apply to RWRS. Performance shall conform to the following specifications: ISO 668, ISO 1161, ISO 1496-1, and ISO 1496-2. See 10.1 for verification test.

8. Dimensions

8.1 *Dimension*—The external dimensions of the RWRS in shipping configuration shall not exceed 8-ft high by 8-ft wide. ISO shelter dimensions shall comply with ISO 668.

8.2 *Door Sizes*—Door sizes shall be as indicated in Table 1.

9. Sampling

9.1 *Samples*—Samples for testing shall be taken from the finished product whenever possible. When the thickness or shape of the finished product makes it impossible to obtain the type of samples specified in the various test methods, the manufacturer shall, upon request by the purchaser at the time of ordering, furnish a sufficient number of test articles, prepared in accordance with good testing practices for the proper performance of the required tests.

10. Tests Required

10.1 *ISO RWRS Compatibility Test*—The RWRS designated ISO shelters shall be examined according to ISO 668 and ISO 1161 and shall be tested in accordance with ISO 1496-1 and ISO 1496-2.

10.2 *Air Transportability Test*—The air transportability test for the RWRS of each size and type shall be tested in accordance with MIL-STD-1791. The RWRS developer may require the application of alternative equipment restraint test instead of an analytical equipment restraint test.

10.3 *Ground Mobility Test*—The ground mobility test for the RWRS using the appropriate mobilizer (dolly set) or vehicle as the transport means shall be tested as prescribed in MIL-M-8090F, Type V Mobility.

10.4 *Rail Transportability Test*—The RWRS rail transportability shall be tested in accordance with MIL-STD-810E, Method 516.4, Procedure VIII. Payload will be distributed to simulate the weight, center of gravity, and mounting profile of mounted equipment. Rail Transportability Tests shall be performed for impacts at 4, 6, and 8 mph (6, 10, and 13 km/h) and

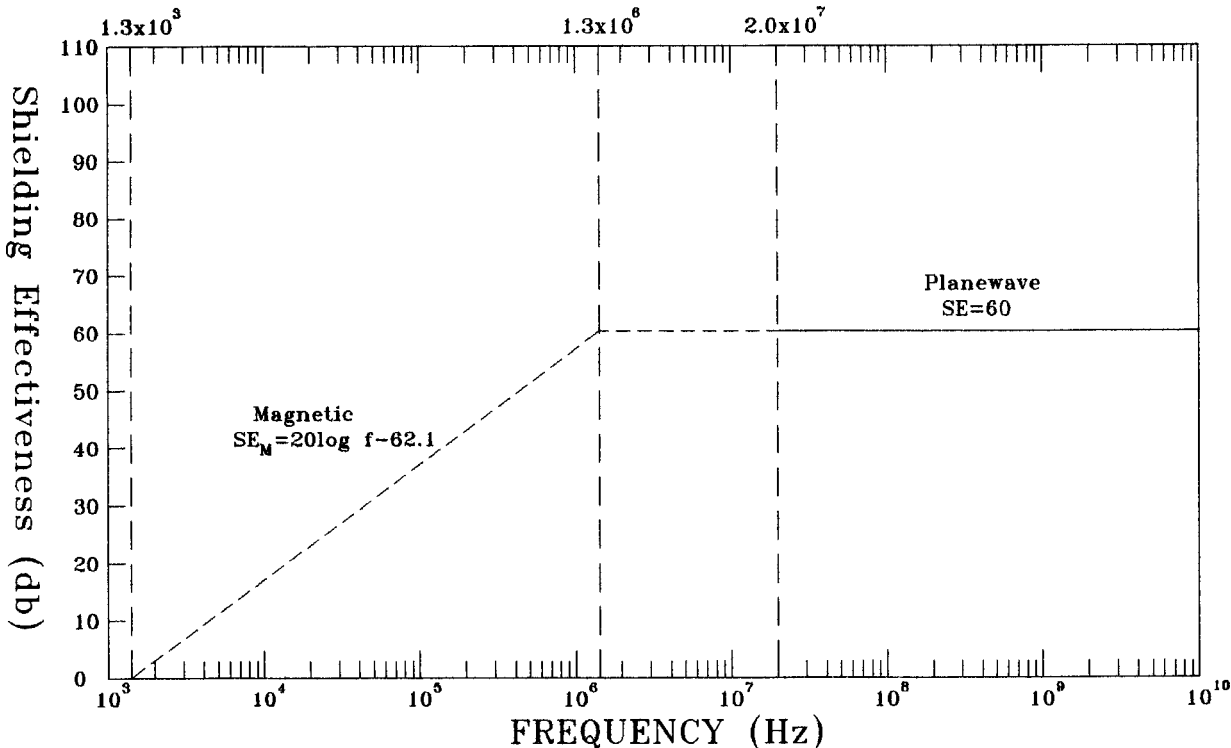

FIG. 1 Minimum Shielding Effectiveness Requirements

TABLE 1 Door Sizes

ISO	Dimension, in. (mm)	NON-ISO
Fixed Walls		
76 ^A × 36 (1930 × 910)		65 × 35 (1650 × 890)
76 ^A × 48 (1930 × 1220)		55 × 30 (1400 × 760)
76 ^A × 72 (1930 × 1830) (double doors)		
Expandable Walls		
76 ^A × 30 (1930 × 760)		65 × 35 (1650 × 890)

^AThis is a minimum value.

8 mph (13 km/h) reversed.

10.5 *Forklift Handling Test*—Loaded with payload distributed to simulate the weight, center of gravity, and mounting profile, the RWRS shall be picked up, transported over a paved surface for 500 yards (460 m) at 8 ± 1 mph (13 ± 1.6 km/h), complete two 90° right turns and two 90° left turns at a reduced safe speed (approximately 5 ± 1 mph (8 ± 1.6 km/h)), and then be lowered to the ground. Tiedown cables or chains shall be required to secure RWRSs without forklift pockets. The test shall be performed using a forklift capable of lifting a fully loaded RWRS and shall be performed once for each insertion point on the RWRS. The forklift tines shall be inserted completely under the RWRS and into the forklift pockets, if applicable, and the RWRS shall be raised off the ground upon contact with the tip of the forklift tines. There shall be no permanent deformation, delamination, or sealer separation within the RWRS structure except for minor abrasions from the forklift tines.

10.6 *Erecting and Striking Test*—The RWRS under test shall be placed on the surface that has a 24-in. (610-mm) differential in grade across the diagonal dimension of the floor of the erected RWRS (by using blocks, etc.). If appropriate, the RWRS shall be leveled and expanded, and made ready for use within a period equal to two man-hours for each 150 ft² (14 m²) of erected RWRS floor space. Striking shall be accomplished in a similar or shorter time period. Consideration must be given in RWRS design to allow for erection and striking in winds up to 30 mph (50 km/h).

10.7 *Airtightness Test for Expandable RWRSs*—Airtightness test, shipping, and operational configuration for expandable RWRSs are as follows:

10.7.1 *Shipping Configuration*—The maximum allowable internal air leakage is 200 standard cubic feet per minute (scfm) (0.10 m³/s) at 0.3 in. of H₂O (75 Pa). Test: An air supply to the RWRS (with all openings closed) and an internal pressure of 0.3 in. of H₂O (water gauge) (75 Pa) shall be obtained and maintained. The air flow shall be stabilized. Any additional air supplied to maintain specified internal pressure shall be recorded to determine compliance with above.

10.7.2 *Operational Configuration*—The maximum allowable internal air leakage is 100 scfm (0.05 m³/s) at 0.3 in. of H₂O (75 Pa). Test: same as 10.7.1

10.8 *Airtightness Test for Nonexpandable RWRSs*—The airtightness test, shipping and operational configuration for non-expandable RWRSs is as follows:

10.8.1 *Shipping and Operational Configurations*—The maximum allowable air leakage is 200 scfm (0.10 m³/s) at 1.2 in. of H₂O (300 Pa). For the test, an air supply to the RWRS (with all appropriate openings closed) and a internal pressure of 1.2 in. of H₂O (water gauge) (300 Pa) shall be obtained and maintained in both the shipping and operational configurations. The air pressure and air flow shall be stabilized. Any additional air supplied to maintain specified internal pressure shall be recorded to determine compliance with the above.

10.9 *Blackout Test*—The RWRS shall be tested in the operational mode for light tightness with a bare 100 W incandescent lamp operating at rated voltage and held anywhere in a plane 1 ft (0.3 m) from the outside wall and roof surfaces. No direct rays of light shall be seen by an observer stationed inside the darkened closed RWRS as the lamp is moved outside.

10.10 *Humidity Resistance Test*—With the doors open, the RWRS shall be subjected to MIL-STD-810E, the moisture resistance test, Method 507.3, Procedure II, for hot-humid conditions. There shall be no evidence of delamination, cracking, corrosion, or deterioration of any part of the RWRS after cycling has been completed.

10.11 *Marine Atmosphere Test*—One representative sample of all fasteners, jacks, seals, and other hardware that will be exposed to the atmosphere in the operational or storage mode and finished in accordance with MIL-STD-810E, Method 509.3, except that the salt solution shall have a concentration of 10 % and the exposure period shall be 96 h. The test items shall display no evidence of corrosion or degradation upon completion of the test.

10.12 *Temperature Test*—The RWRS shall be tested for both high temperature and low temperature storage and operating temperatures as described below. Upon completion of the temperature test, the RWRS shall sustain no delamination nor shall there be damage to seals or other components and all hardware shall operate during and after completion of temperature testing.

10.12.1 *High Temperature Test*—The RWRS shall be tested in accordance with MIL-STD-810E, Method 501.3. Storage temperature shall be maintained at a constant temperature of 160°F (71°C) for 4 h. Personnel shall be capable of erecting and striking the shelters and the doors shall be fully operable. Operational temperature shall be 120°F (49°C). The RWRS shall be fully operable. The solar load test is identified in 10.13.

10.12.2 *Low Temperature Test*—The RWRS shall be tested in accordance with MIL-STD-810E, Method 502.3. The storage temperature shall be maintained at a constant temperature of -70°F (-57°C) 4 h. Personnel shall be capable of erecting and striking the shelters and the doors shall be fully operable. Operational temperature shall be -40°F (-40°C). The RWRS shall be fully operable.

10.13 *Solar Load Test, Assembled RWRSs*—With the RWRS in operational mode, a simulated solar load sufficient to raise the outer skin temperature to 205°F (96°C) shall be applied uniformly to the fixed roof and one folding or expanded roof. A uniform solar load temperature should be attained gradually within 4 h and shall be maintained for an additional 4 h. As a minimum, one thermocouple per 10 ft² (1

m²) of roof shall be uniformly distributed on the entire area of the roof. All of the thermocouples should read 205 ± 15°F (96 ± 8°C) throughout the 4-h period that the solar load shall be maintained. During this test, the ambient temperature within the RWRS will be maintained at a maximum of 85°F (29°C). The roof panels shall be examined upon completion of the solar load test, and any evidence of delamination or deformation will constitute failure of this test.

10.14 *Temperature Shock Test*—A representative RWRS panel specimen measuring 4 by 8 ft (1.2 by 2.4 m) shall be tested in accordance with MIL-STD-810E, Method 503.3. The high temperature chamber shall be at 160°F (71°C) and the low temperature shall be set at -70°F (-57°C). The sample will be checked for evidence of degradation of physical properties. Windows and other components shall also be tested.

10.15 *Heat Transfer Test*—The RWRS shall be erected inside a chamber with an automatic control system for maintaining a constant minimum temperature of -25°F (-32°C) when the temperature inside the RWRS is maintained at 75°F (23°C). The volume of the test chamber shall be such that the bulk of the RWRS will not interfere with the generation and maintenance of test conditions. The minimum distance from any RWRS panel to adjacent chamber wall shall be 24 in. (610 mm). The conditioned air flow shall be suitably baffled to provide free circulation between the RWRS and the chamber walls and ceiling and to provide uniform air flow around the RWRS with the maximum velocity on the RWRS surface of 5 mph (8 km/h). The chamber temperature shall be measured by placing one thermocouple 6 in. (150 mm) away from each corner fitting, and one thermocouple centrally located 6 in. (150 mm) away from each wall and ceiling panel. For ISO-type RWRS, internal temperature shall be measured with a total of 16 thermocouples, with each located 6 in. (150 mm) away from the panel surface, each shielded from the heat source and positioned as shown in Fig. 2. For non-ISO RWRS, internal temperature shall be measured with a minimum total of ten thermocouples. An electrical resistance heat source, with sufficient power to maintain a stabilized temperature of not less than 100°F (56°C) above the outside temperature, shall be used. A heater providing air discharge radially in a 360° pattern, with adjustable louvers around the circumference and

discharge louvers in the top, is the preferred item for providing uniform heat. Additional fans may be used to ensure that the difference between any two thermocouples is a maximum of 5°F (3°C), thereby providing a uniform temperature within the RWRS. Also, the heater resistance elements shall be completely shielded from any interior RWRS surfaces. Temperature conditions shall be considered stable when, for 30 min, internal thermocouple readings remain within 5°F (3°C) of one another while the average external temperature remains at -25° ± 5°F (-32 ± 3°C) and the average internal temperature remains a minimum of 100°F (56°C) above the average external temperature. Thermocouple readings shall be recorded every 15 min. After the temperature conditions have stabilized and while maintaining stability, the electrical power to the internal apparatus shall also be recorded every 15 min during which time the power shall not be changed and all apparatus shall operate continuously. Four sets of power readings shall be recorded with an allowable variation of 5%. The overall coefficient of heat transfer shall be calculated using the average internal and external temperatures, amount of electrical power consumed, and nominal internal surface area.

$$U = \frac{\text{total power consumed - Btu/hr (watts)}}{SA \times \Delta T} \quad (1)$$

where:

SA = Nominal inside surface area - ft²(m²), and

ΔT = Temperature Difference - °F (°K).

The calculated values of the overall heat transfer coefficient shall then be averaged to determine the final average value for the overall heat transfer coefficient.

10.16 *Blowing Sand Test*—The external moving components of the RWRS shall be installed in the sand test chamber. The air velocity and performance shall be as described in MIL-STD-810E, Method 510.3, Procedure II, except the sand particle size shall be as follows:

1000 μm	100% passing mesh screen
500 μm	98% ± 2% passing mesh screen
150 μm	90% ± 2% passing mesh screen

10.17 *Sunshine (Ultraviolet Effects) Test*—A sunshine (ultraviolet effects) test shall be conducted on all external components subject to solar degradation, in accordance with MIL-STD-810E, Method 505.3, Procedure II.

10.18 *Fire Resistance Test*—Two specimens of a production sandwich panel 12 by 12 in. (300 by 300 mm) shall be tested for flammability. The specimens shall be prepared and tested in the following manner:

10.18.1 Drill a 1/4-in. (6 mm) hole in the center of the panel through both skins.

10.18.2 Using a 1-in. (25 mm) diameter hole saw with a 1/4-in. (6 mm) pilot, remove the skin only on each side within a 1-in. (25 mm) diameter area.

10.18.3 Mount the panel in any appropriate holding fixture in a horizontal position.

10.18.4 Adjust the height of the panel so that the lower skin is approximately 2-1/2 in. (64 mm) above the top of a standard barrel Bunsen burner.

10.18.5 Adjust the flame height to approximately 5 in. (125 mm) with an inner core of approximately 3 in. (75 mm).

10.18.6 Apply the flame to the center of the hole in the skin,

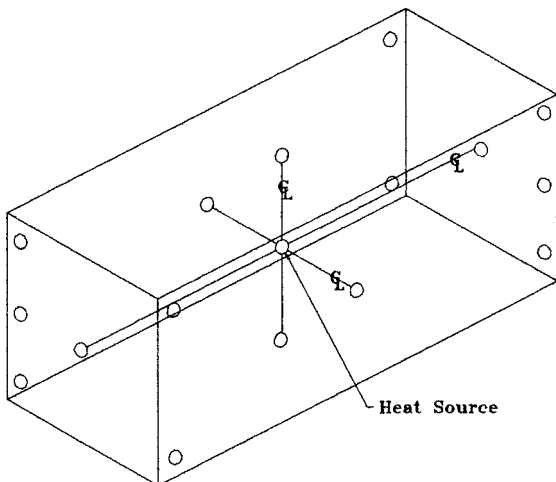

FIG. 2 Thermocouple Locations

impinging on the core, for 30 s.

10.18.7 At the end of the 30-s period, remove the flame and record the time, in seconds, for burning or glowing to cease, if ignition occurs. The specimen shall be nonburning or self-extinguishing within 30 s and shall exhibit no degradation (charring) of material outside a 1.25-in. (32-mm) radius from the center point of the drilled hole.

NOTE 1—Tests shall be conducted from each side of the panel when the panel cross-section is not symmetrical.

10.19 *Fungus Test*—All material components shall be certified for resistance to fungal growth. Where certification does not exist, the material shall be plate tested per Practice G 21 to verify fungus resistance.

10.20 *RWRS Squareness Test*—The RWRS squareness shall be tested. Measurements shall be taken at the top, middle, and bottom of each of the four vertical corners. Using a 36-in. (900-mm) square, measurements shall be taken at the mounting members or at 24-in. (610-mm) intervals for intersecting RWRS wall, floor, and roof panels containing mounting members. Ten or more gaps, in the lot of measurements taken, in excess of $\frac{1}{16}$ in. (2 mm) shall be cause for rejection of the unit.

10.21 *Panel Flatness Test*—The flatness of the panel shall be inspected using a 48-in. (1200-mm) long straight edge that is flat within 0.005-in. (0.1-mm) total. Two $\frac{1}{16}$ -in. (2-mm) shims shall be used along the straight edge, located at the extremes of the edge. Measurements will be taken in both horizontal and vertical directions on the RWRS walls. Panels found to be bowed or cupped, greater than 0.125 in. (3 mm) per each 4-ft (1.3-m) length measured across the RWRS walls both horizontally and vertically shall be rejected.

10.22 *Roof Loads Test*—A roof loads test shall subject the RWRS to a uniform loading of 40 lb/ft² (200 kg/m²) over the fixed and folding roof surface. After removal of the uniform load, place a 660 lb (300 kg) load over 2 ft² (0.2 m²) at the weakest area of the fixed roof and an identical load on the folding roof. Each test shall be for a duration of 5 min. The RWRS will be visually inspected for any evidence of structural damage, delamination, permanently popped seals, panel separation, etc., both during and subsequent to removal of the load.

10.23 *Floor Loads Test*—With RWRS in operational configuration, the expanded floor shall be uniformly loaded to 65 lb/ft² (320 kg/m²) and left in position for 30 min. Prior to removal of the uniform load, all moveable parts shall be operated to ensure that no interference exists between components. After completion of the above test, the uniform load shall be removed and a concentrated 2,000-lb (900 kg) load shall be applied over a 4 ft² (0.4 m²) area centered on the floor and left in position for 30 min. Prior to removal of the concentrated load, all moveable parts shall be operated to ensure that no interference exists between the components. After completing both of the above tests, the concentrated load shall be removed and a point load of 125 lb (57 kg) balanced atop a 1 in² (650 mm²) block shall be applied for a 5-min test to the center of the fixed and expanded floor. A thorough inspection shall be made after each test to observe that there is no evidence of structural damage, delamination, or permanent deformation.

10.24 *Door Loads Test*—Doors shall be tested to withstand the following tests without deformation or impairment of function:

10.24.1 *Door Loads Test-Static Load*—Each door shall have a vertical 200-lb (90-kg) load applied at the edge opposite from the hinge pivot as applicable with door open to 90°. The load shall be removed and the door examined after 30 min. Any evidence of unbonded components, damage to hardware, or improper door operation shall constitute failure of this test.

10.24.2 *Wind Gust Door Loads Test*—A wind gust load test shall be performed with the door in the open position(s), held by the door stop device(s). A fixture shall be attached to the midpoint of the locking edge of the door that shall permit application of the following horizontal forces, using free running pulleys to transmit the forces from weights and a $\frac{1}{4}$ -in. (6-mm) diameter steel cable (the RWRSs and pulley frames shall be rigidly held in place):

- (1) A static load of 10 lb/ft² (50 kg/m²) times door area in ft².
- (2) A dynamic load of 50 lb (20 kg).

The weight shall be dropped five times from a height of 12 in. (300 mm). This test shall be performed from both sides of the open door. The door and its associated RWRS mountings and parts shall show no evidence of deformation after the test.

10.25 *Panel Attachment Points Test*—A panel attachment points test shall be conducted where a tensile load, which is panel thickness dependent, shall be applied to panel attachment points as follows: 2,000 lb (900 kg) for panel thickness equal to or greater than 2 in. (50 mm) and 1,000 lb (450 kg) for panels less than 2 in. (50 mm) thick.

(1) For panel designs containing mounting members, a $\frac{5}{16}$ -18 (M8 \times 1.25) threaded insert⁶ shall be used.

(2) For panel designs not containing mounting members, a $\frac{1}{4}$ -28 (M6 \times 1.00) potted insert⁷ shall be used.

This shall be followed by a torque load of 100 inch-pounds (11 Nm) applied to the insert. There shall be no distortion of the panel, mounting member if contained, or insert and the insert shall not have rotated from its original position after the loads have been removed.

10.26 *Leveling Devices Test*—RWRSs with leveling devices (jacks) shall be subjected to the following tests. While carrying no vertical load, the device shall be attached to the RWRS, and four successive 2,000-lb (900 kg) pulls shall be applied to the same device, with the RWRS securely fixed, at a given distance from the lower attachment point. This distance is defined as the maximum height that the leveling devices must be raised under the different modes of operation, with a minimum distance of 24 in. (610 mm). The four pulls shall be perpendicular to the device and 90° apart in line with the wall and ends. The leveling device attachment provisions for the RWRSs and the RWRS itself shall sustain no damages as a result of the above test.

10.27 *Lifting and Towing Provision Strength Test*—Each lifting and towing eye provision on the RWRS shall be subjected to a tensile load applied in each of three mutually perpendicular directions that are described by the line of

⁶ B.F. Goodrich Rivnut available from B.F. Goodrich.

⁷ Shur-loc SL601-4-11-C available from Shur-Lok Corp., Irvine, CA 92714.

intersection of two adjacent panels. The test shall be performed by outward pulls between each adjacent pair of eye provisions. All pulls shall be equal to 2.26 times the gross weight of the RWRS. The lifting and towing eye provision assemblies shall be subjected to a tensile load equal to 2.26 times the gross weight of the RWRS applied in each of the three mutually perpendicular directions described above. Each lifting and towing eye assembly installed on the RWRS shall be capable of withstanding the above specified loads with no cracking or permanent deformation to the eye provision assembly or RWRS and no sealer separation or cracking around the assembly.

10.28 Tow and Dragging Simulator (for RWRS with Skids) Test—The RWRS, with attached skids and with the maximum payload, shall be placed so that the outer face of the roadside skid is flush against a rigidly secured restraining beam that runs the full length of the skid. A force equal to one-half the RWRS gross weight shall be applied separately to each roadside towing eye, in a direction parallel to the ground and perpendicular to the side of the RWRS. The skid restraining beam shall be of a height that prevents the RWRS from moving under the applied force and that will allow loads to be imparted through all components of the skid assembly and skid mounting bracket. The test shall be repeated on the curbside skid and towing eyes. In all cases, the RWRS shall be supported to prevent sliding.

10.29 Drop Shock Test (All RWRS Without Skids)—RWRSs without skids shall be capable of withstanding flat and rotational drop tests as follows: There shall be no permanent deformation, buckling, delamination, sealer separation, or structural failures of any part of the RWRS after each test, and the doors and covers shall open and close to their full extent without binding.

10.29.1 Flat Drop Test without Skids—The RWRS loaded with its maximum payload uniformly distributed shall be lifted $6 \pm \frac{1}{4}$ in. (150 ± 6 mm) from the ground and allowed to fall freely with the bottom impacting onto a concrete surface. The RWRS shall exhibit no longitudinal or transverse swing in excess of 0.5 in. (13 mm) while in the raised position, prior to dropping. This test shall be performed once.

10.29.2 Rotational Drop Test without Skids—With the RWRS loaded with its maximum payload uniformly distributed, place one edge of the RWRS on a nominal 4-in. (nominal 100-mm) high block. Raise the opposite edge of the RWRS $6 \pm \frac{1}{4}$ in. (150 ± 6 mm) and then allow the unit to fall freely onto a concrete surface using the 4-in. (100-mm) block as a pivot. Perform this test once on each of the four bottom edges of the RWRS.

10.30 Drop Shock Test (RWRS With Skids)—RWRSs with shock attenuating skids shall be capable of withstanding flat and rotational drop tests as follows: There shall be no permanent deformation, buckling, delamination, sealer separation, or structural failures of any part of the RWRS after each test, and the doors and covers shall open and close to their full extent without binding.

10.30.1 Flat Drop Test with Skids—The RWRS loaded with its maximum payload uniformly distributed shall be lifted $18 \pm \frac{1}{4}$ in. (460 ± 6 mm) from the ground, as measured from the

bottom of the skids, and allowed to fall freely with the skids impacting into a flat concrete surface. The RWRS shall exhibit no longitudinal or transverse swing in excess of 0.5 in. (13 mm) while in the raised position, prior to dropping. This test shall be performed once.

10.30.2 Rotational Drop Test with Skids—With the RWRS loaded with its maximum payload uniformly distributed, a 4-in. (100-mm) high nominal board shall be placed under the skid(s) at one edge of the RWRS. The opposite edge of the RWRS shall be raised $18 \pm \frac{1}{4}$ in. (460 ± 6 mm) from the ground at the two raised corners, as measured at the bottom of the skids, and allowed to fall freely so that the skid(s) impact(s) onto the concrete surface. This rotational drop test shall be performed on each bottom edge of the RWRS.

10.31 Impact Resistance Test—A 24-in. (610-mm) sample of all floor and roof RWRS panels shall withstand a blow from a 70-lb (30-kg) steel cylinder 3 in. (80 mm) in diameter with a hemispherical end, dropped from a height of 30 in. (800 mm). Samples of all other exterior panels shall withstand a blow from the same steel cylinder dropped from a height of 16 in. (410 mm). Impact shall not result in rupture of the impacting or opposite skin, or both. No delamination of the opposite skin to core is allowed. Outside a 3-in. (80-mm) radius (except $3\frac{1}{2}$ in. (90 mm) radius for fixed floor panel) from the “center of impact” (which shall coincide with the approximate center of the test panel specimen), no delamination of impacting skin to core shall be allowed and crushing or collapsing of the core shall not be allowed. Outside a five inch radius from the “center of impact” (which shall coincide with the approximate center of the test panel specimen), core shear failure shall not be allowed.

10.31.1 All panel surfaces that are exterior surfaces in the RWRS transportation mode or floor or roof surfaces in the RWRS operational mode shall be impact resistance tested. A specimen of a panel requiring testing shall receive a blow from a 70-lb (30-kg) steel cylinder dropped from a specified height onto the appropriate panel surface. Floor and roof surfaces shall be tested at a drop height of 30 in. (800 mm). Panel surfaces that are exterior surfaces in the RWRS transportation mode shall be tested at a drop height of 16 in. (410 mm). If a panel surface fits both categories then the 30-in. (800-mm) drop height test will be applied. If a panel bears a floor or roof surface on one side and an exterior surface on the other side, then a specimen shall receive a floor/roof-side impact from 30 in. (800 mm) and a second specimen shall receive an impact to the opposite side from 16 in. (410 mm). The impact resistance specimen shall be fabricated in accordance with Fig. 3. The specimen shall contain only one continuous piece of core material (without structural members or core splices) bonded with the same adhesive as that used in the RWRS panel (without voids or delaminations to the facings). The specimen shall be supported along its four edges by a framework backed by concrete. The framework shall be made of four pieces of 2 by 4-in. (50×100 -mm) nominal softwood lumber. The frame shall be rigidly bolted together to form a square 24 in. (610 mm) on a side (outside dimensions) and 4-in. (100-mm) nominal high. The frame shall rest on the 24-in. (610-mm) nominal wide face. The specimen shall be bolted to the frame

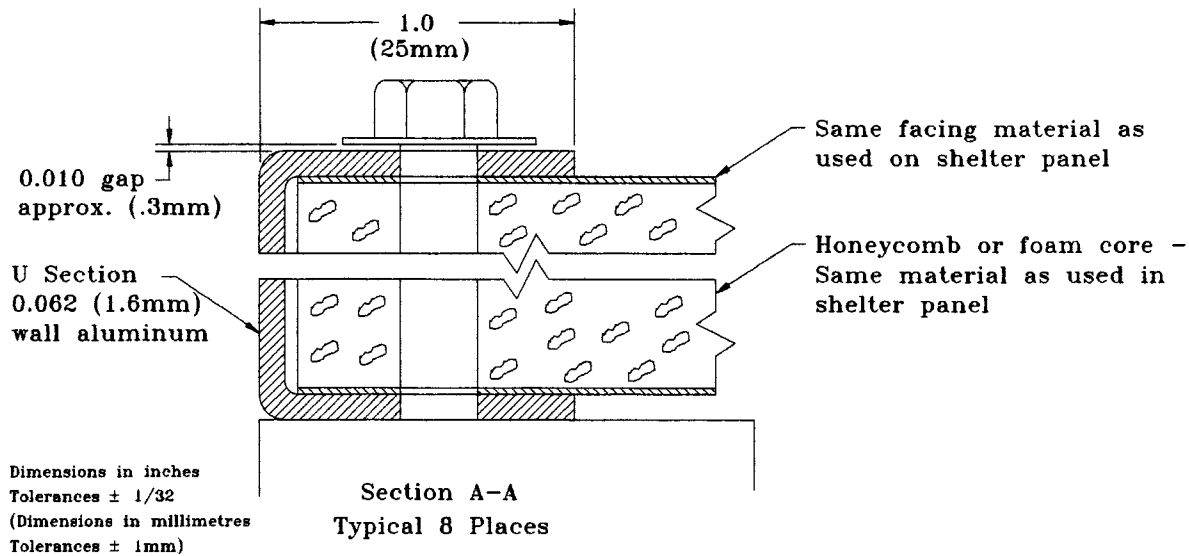
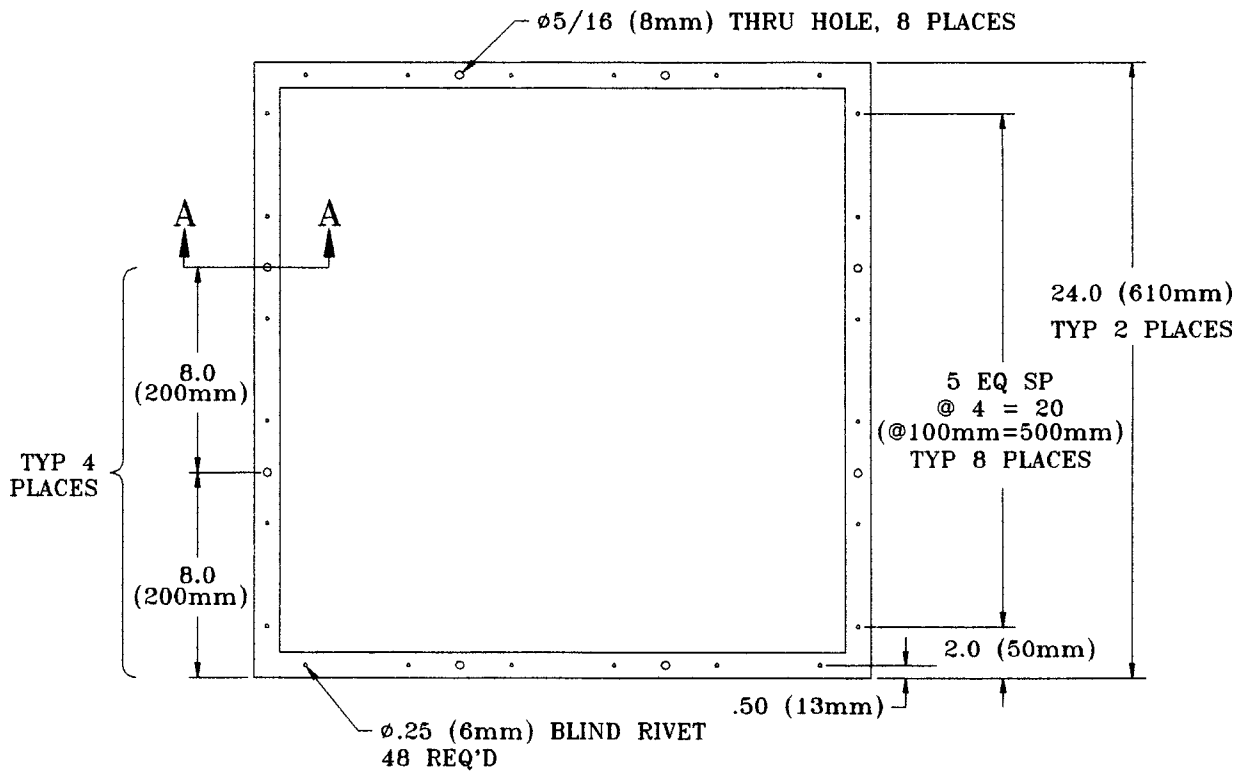

FIG. 3 Impact Resistance Specimen

with two 1/4-in. (6-mm) diameter bolts per edge. Care should be taken that the appropriate surface of the specimen faces the impact. The bolts shall be tightened against the specimen and then backed off so that there is a gap of 0.010-in. (0.3-mm) nominal between the bolt head and the panel. The specimen shall be impacted with a steel cylinder 3 in. (80 mm) in diameter and hemispherical at one end. The cylinder shall be oriented and dropped vertically so that the center of the hemispherical end of the cylinder strikes the center of the specimen on a horizontal plane. The cylinder shall not be permitted to re-impact the specimen after the first impact. The

test specimen shall be cross-sectioned through the impact area and visually examined for conformance with the specified requirements.

10.32 *EMI Provisions Test*—To verify conformance to this specification, the RWRS shall be tested in accordance with Test Method E 1851. The test shall be conducted at the following fields and frequency ranges.

10.32.1 Magnetic field: A minimum of two frequencies in the range of 100 kHz to 20 MHz in accordance with the Test Method E 1851.

10.32.2 Plane wave field: A minimum of three frequencies

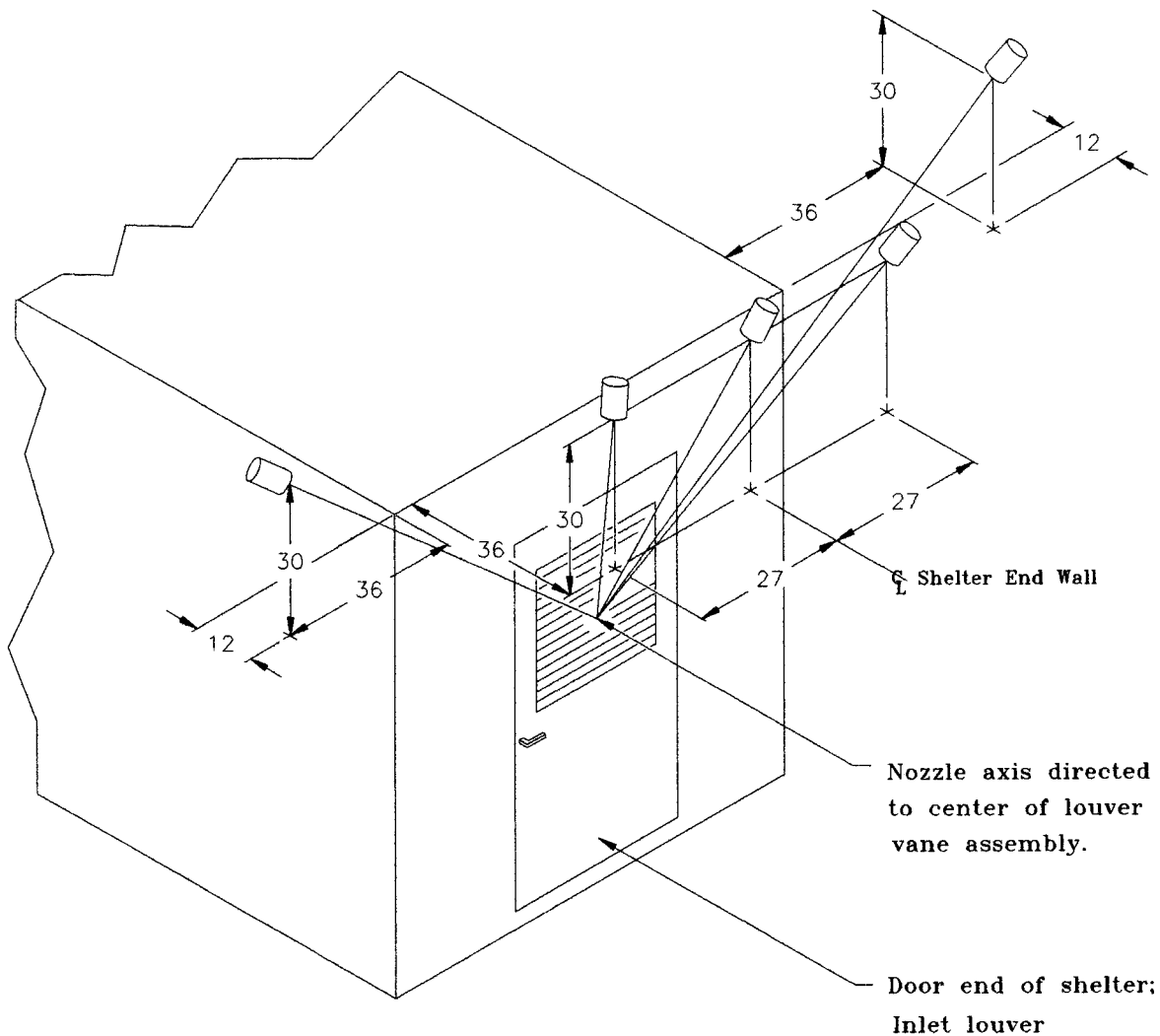

NOTES:

1. Gages shall be permanently installed to indicate pressure at remote nozzles.
2. Air inlet cover shall be fully open.
3. Dimensions shown are in inches.

FIG. 4 Nozzle Locations for the Watertightness Test Louvers

in the range of 300 MHz to 10 GHz in accordance with the Test Method E 1851.

10.32.3 Electric field: None.

10.32.4 Additional shielding effectiveness tests may be performed in the range of 100 kHz to 10 GHz. For specific applications, the frequency range may be extended from 50 Hz to 40 GHz. The shielding effectiveness test shall be considered passed if the RWRS provides the required minimum shielding effectiveness specified in Fig. 1 in the range of 100 kHz to 10 GHz. Likewise the shielding effectiveness test shall be considered failed if the RWRS failed to provide the required minimum shielding effectiveness specified in Fig. 1 at each frequency and test point when tested in accordance with Test Method E 1851.

10.33 *Watertightness Test*—The RWRS, without the use of any external sealing, caulking, taping, etc., shall be subjected

to the following two-part test when required. For compliance, the test item shall be weighed before and after each of the following tests. Weight differential shall not exceed 1 lb.

10.33.1 *Panels*—Each exposed surface of the RWRS, with doors and covers closed, shall be sprayed with water from nozzles.⁸ Nozzles shall be symmetrically distributed across each side, roof, and end panel tested. Side and end panels shall be tested using one nozzle per 6 ft²(0.5 m²) surface area. Nozzles shall be located perpendicular to and 19 in. (500 mm) from the panel surface. Roof panels shall be tested using one nozzle per 14 ft²(1.5 m²) surface area. Nozzles shall be located perpendicular to and 32 in. (800 mm) from the panel surface.

⁸ Model G29SQ or GG29SQ available from Spraying Systems Co., Bellwood, IL.

In all cases, panels shall be sprayed continuously for a period of 40 min and nozzle input gage pressure shall be 40 psi (2.8 kg/cm²). Prior to the performance of the spraying, the door of the RWRS shall be fully opened and closed so that the latching mechanism is completely engaged for a total of ten operations. There shall be no evidence of leakage into the RWRS.

10.33.2 *Louvers*—The inlet louver shall be tested with the door closed and the louver cover fully open, by spraying water at the door and end panel. Five nozzles, as used above, shall be used; they shall be located in accordance with Fig. 4. Each nozzle shall operate at a gage pressure of 15 psi (1.1 kg/cm²) at the nozzle. The panel shall be sprayed continuously for a period of 20 min. After both parts of this test, there shall be no evidence of leakage into the RWRS or into the walls, floor, roof, or door. For all RWRSs except the honeycomb type, to determine that no water has entered the space between the skins, holes shall be made (not less than four nor more than ten) at points to be determined by the procuring organization at the time of testing and the RWRS tilted to allow the water to run towards the holes. There shall be no evidence of water. After this determination, the holes shall be sealed with rivets and sealer.

10.34 *Lift Test 3.2G*—The RWRS shall be prepared and tested in the following manner:

10.34.1 *ISO RWRS:*

10.34.1.1 The RWRS shall be prepared such that the total weight is 3.2 times the gross weight. The payload may be in any convenient form that may be uniformly distributed over the floor. If solid weights are used, the floor will be protected from sharp objects by ½ to ¾-in. (13 to 19-mm) thick plywood covering the floor. (The RWRS must be located on a flat, solid surface while the loads are installed.)

10.34.1.2 Close all doors and panels securely.

10.34.1.3 Connect a four-legged sling to the upper ISO fittings maintaining a 60° minimum angle with the roof (see Fig. 5).

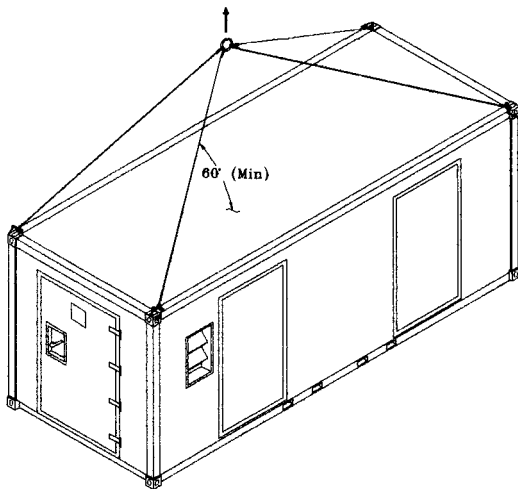

NOTE - The payload is equal to 3.2 times the gross weight minus shelter tare weight.

FIG. 5 Lifting Upper Fittings

10.34.1.4 Applying minimal acceleration forces, raise the RWRS from the ground and allow to remain suspended for 5 min.

10.34.1.5 Slowly lower the RWRS to the ground and inspect for signs of damage.

10.34.1.6 Repeat the test by lifting the RWRS from the lower ISO fittings as shown in Fig. 6.

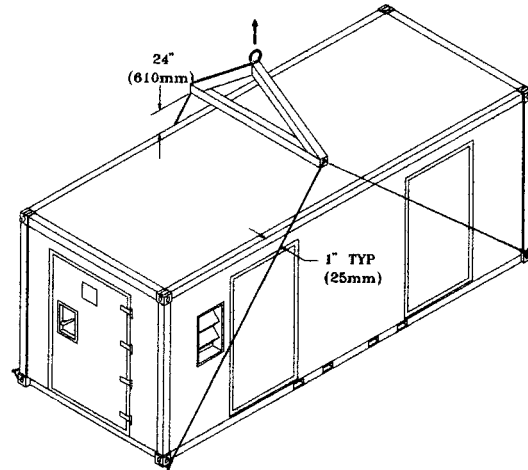

NOTE - The payload is equal to 3.2 times the gross weight minus shelter tare weight.

FIG. 6 Lifting from Bottom

10.34.1.7 Remove the payload.

10.34.1.8 Erect the RWRS and thoroughly inspect the RWRS for damage. Any evidence of permanent deformation, cracking, unbonded components, or loosening of structural components shall constitute failure of this test.

10.34.2 *Non-ISO RWRS:*

10.34.2.1 The RWRS shall be prepared such that the total weight is 3.2 times the gross weight. The payload may be in any convenient form that may be uniformly distributed over the floor. If solid weights are used, the floor will be protected from sharp objects by ½ to ¾-in. (13 to 19-mm) thick plywood covering the floor. (The RWRS must be located on a flat solid surface while the loads are installed.)

10.34.2.2 Close all doors and panels securely.

10.34.2.3 Connect a combination lift and tie down device if specified for and normally shipped with this perpendicular RWRS or a four-legged sling to each RWRS lifting eye and to the hook of the hoist.

10.34.2.4 Applying minimal acceleration forces, raise the RWRS from the ground and allow it to remain suspended for 5 min.

10.34.2.5 Slowly lower the RWRS to the ground and inspect for signs of damage.

10.34.2.6 Remove the payload.

10.34.2.7 Erect the RWRS and thoroughly inspect it for damage. Particular attention shall be given to the area around the four lifting eyes. Any evidence of permanent deformation, cracking, unbonded components, or loosening of structural components shall constitute failure of this test.

11. Keywords

11.1 adhesive bonded; aluminum; bonding; expandable; honeycomb sandwich panels; non-expandable, foam and beam panels; relocatable buildings; relocatable structures; rigid wall shelters

APPENDIX

(Nonmandatory Information)

X1. LIST OF ACRONYMS AND ABBREVIATIONS

ASTM	American Society for Testing Materials	km	kilometre
Btu/h	British thermal units per hour	kHz	kilohertz
C	Centigrade	lb	pound
dB	decibels	m	metre
EMI	electromagnetic interference	m ²	square metre
F	Fahrenheit	m ³	cubic metre
ft	feet	mm	millimetre
ft ²	square feet	mph	miles per hour
ft ³	cubic feet	min	minutes
G	gravity	MHz	megahertz
GHz	gigahertz	psig	pounds per square inch gage
g/m ²	grams per square metre	RWRS	Rigid Wall Relocatable Structure
h	hour	scfm	standard cubic feet per minute
H ₂ O	water	SA	Surface Area
Hz	Hertz	ΔT	Temperature Difference
in-lb	inch pound	yr	year
ISO	International Organization for Standardization		
kg	kilogram		

The American Society for Testing and Materials takes no position respecting the validity of any patent rights asserted in connection with any item mentioned in this standard. Users of this standard are expressly advised that determination of the validity of any such patent rights, and the risk of infringement of such rights, are entirely their own responsibility.

This standard is subject to revision at any time by the responsible technical committee and must be reviewed every five years and if not revised, either reapproved or withdrawn. Your comments are invited either for revision of this standard or for additional standards and should be addressed to ASTM Headquarters. Your comments will receive careful consideration at a meeting of the responsible technical committee, which you may attend. If you feel that your comments have not received a fair hearing you should make your views known to the ASTM Committee on Standards, at the address shown below.

This standard is copyrighted by ASTM, 100 Barr Harbor Drive, PO Box C700, West Conshohocken, PA 19428-2959, United States. Individual reprints (single or multiple copies) of this standard may be obtained by contacting ASTM at the above address or at 610-832-9585 (phone), 610-832-9555 (fax), or service@astm.org (e-mail); or through the ASTM website (www.astm.org).