



## Standard Specification for Shelter, Electrical, Equipment S-280/G<sup>1</sup>

This standard is issued under the fixed designation E 1975; the number immediately following the designation indicates the year of original adoption or, in the case of revision, the year of last revision. A number in parentheses indicates the year of last reappraisal. A superscript epsilon ( $\epsilon$ ) indicates an editorial change since the last revision or reappraisal.

### 1. Scope

1.1 This specification covers one type of lightweight field and mobile shelter designed for transport by cargo truck, fixed or rotary winged aircraft, by rail, and ship, as Shelter, Electrical Equipment S-280/G (see 15.5).

1.2 The values stated in inch-pound units are to be regarded as the standard. The values given in parentheses are for information only.

1.3 The following safety hazards caveat refers only to the test methods described in this specification. *This standard does not purport to address the safety concerns, if any, associated with its use. It is the responsibility of the user of the standard to establish appropriate safety and health practices and determine the applicability of regulatory limitations prior to use.*

### 2. Referenced Documents

#### 2.1 ASTM Standards:

- C 272 Test Method for Water Absorption of Core Materials for Structural Sandwich Constructions<sup>2</sup>
- C 273 Test Method for Shear in Flatwise Plane of Flat Sandwich Constructions or Sandwich Cores<sup>2</sup>
- D 1621 Test Method for Compressive Strength of Rigid Cellular Plastics<sup>3</sup>
- D 1622 Test Method for Apparent Density of Rigid Cellular Plastics<sup>3</sup>
- D 2842 Test Method for Water Absorption of Rigid Cellular Plastics<sup>4</sup>
- E 864 Practice for Preparation of Aluminum Alloys to be Adhesively Bonded in Honeycomb Shelter Panels<sup>5</sup>
- E 1730 Specification for Rigid Foam for Use in Shelter Sandwich Panel Cores<sup>5</sup>
- E 1749 Terminology Relating to Rigid Wall Relocatable Shelters<sup>5</sup>
- E 1773 Practice for Sealing Rigid Wall Tactical Shelters with Polysulfide Based Sealants<sup>5</sup>
- E 1794 Specification for Adhesive for Bonding Foam Cored

Sandwich Panels (200°F Elevated Humidity Service), Type II Panels<sup>5</sup>

E 1801 Practice for Adhesive Bonding of Aluminum Facings in Foam and Beam Type Shelters<sup>5</sup>

E 1851 Test Method for Electromagnetic Shielding Effectiveness of Durable Rigid Wall Relocatable Structures<sup>5</sup>

E 1925 Specification for Engineering and Design Criteria for Rigid Wall Relocatable Structures<sup>5</sup>

#### 2.2 Federal Air Regulation (FAR):

FAR 25.853 Compartment Interior<sup>6</sup>

#### 2.3 Military Standards:

MIL-W-6858 Welding Resistance: Aluminum, Magnesium, Non-Hardening Steels or Alloys, Nickel Alloys, Nickel Alloys, Heat-Resisting Alloys and Titanium Alloys; Spot and Seam<sup>7</sup>

MIL-M-13231 Marking of Electronic Items<sup>7</sup>

MIL-F-14072 Finishes for Ground Electronic Equipment<sup>7</sup>

MIL-DTL-55507 Shelter, Electrical Equipment, (With or Without Equipment), Packaging of<sup>7</sup>

MIL-STD-105 Sampling Procedures and Tables for Inspection by Attributes<sup>7</sup>

MIL-STD-202 Test Methods for Electronic and Electrical Component Parts<sup>7</sup>

MIL-STD-252 Classification of Visual and Mechanical Defects for Equipment, Electronic, Wired, and Other Devices<sup>7</sup>

MIL-STD-810 Environmental Test Methods<sup>7</sup>

MIL-STD-1235 Single and Multilevel Continuous Sampling Procedures and Tables for Inspection by Attributes<sup>7</sup>

MIL-STD-1595 Qualification of Aircraft, Missile and Aerospace Fusion Welders<sup>7</sup>

#### 2.4 Drawings:

SC-D-36423 Hold Down Assembly<sup>8</sup>

SC-C-36424 Cable Assembly<sup>8</sup>

SC-C-200154 Keeper<sup>8</sup>

SM-D-450462 Panel Assembly, Emergency Exit<sup>8</sup>

SM-C-450466 Air Filter<sup>8</sup>

SM-C-555515 Shock Mount<sup>8</sup>

SM-B-563756 Sealer<sup>8</sup>

<sup>1</sup> This specification is under the jurisdiction of ASTM Committee E-16 on Performance of Buildings and is the direct responsibility of Subcommittee E06.53 on Materials and Processes for Durable Rigid Wall Relocatable Structures.

Current edition approved Sept. 10, 1998. Published March 1999.

<sup>2</sup> Annual Book of ASTM Standards, Vol 15.03.

<sup>3</sup> Annual Book of ASTM Standards, Vol 08.01.

<sup>4</sup> Annual Book of ASTM Standards, Vol 08.02.

<sup>5</sup> Annual Book of ASTM Standards, Vol 04.11.

<sup>6</sup> Available from Flight Standards Service, Federal Aviation Administration, 800 Independence Ave., SW, Washington, DC 20591.

<sup>7</sup> Available from Standardization Documents Order Desk, Bldg. 4 Section D, 700 Robbins Ave., Philadelphia, PA 19111-5094, Attn: NPODS.

<sup>8</sup> Available from U.S. Army Natick Research, Development, and Engineering Center, Attn: SSCNC-WST, Natick, MA 01760-5018.

- SC-D-595509 Cover, Emergency Exit<sup>8</sup>
- SC-B-595564 Core Material-Urethane, Light<sup>8</sup>
- SC-B-595565 Core Material-Urethane, Heavy<sup>8</sup>
- SM-D-615264 Intake Louver Assembly<sup>8</sup>
- DL-SC-A-621051 Modification Kit, Radio Frequency Interference, MK-1079/G<sup>8</sup>
- SM-D-781242 Door Fixture (S-280) Construction Tightness Test<sup>8</sup>
- SM-D-781243 Drain Fixture (S-280) Construction Tightness Test<sup>8</sup>
- SM-D-781244 S-280 Construction Tightness Test<sup>8</sup>
- DL-SM-D-947080 Shelter, Electrical Equipment S-280C/G<sup>8</sup>
- SM-D-947080 Shelter, Electrical Equipment S-280C/G<sup>8</sup>
- SM-D-947081 Panel Assembly, Front<sup>8</sup>
- SM-D-947082 Panel Assembly, Rear<sup>8</sup>
- SM-D-947083 Panel Assembly, Roof<sup>8</sup>
- SM-D-947084 Panel Assembly, Floor<sup>8</sup>
- SM-D-947085 Panel Assembly, Side<sup>8</sup>
- SM-D-947141 Corner, Lifting Eye (Machining)<sup>8</sup>
- SM-D-947142 Corner, Towing Eye (Machining)<sup>8</sup>
- SM-D-947143 Casting, Lifting and Towing Eye<sup>8</sup>
- SM-D-947160 Door Jamb Assembly<sup>8</sup>
- SM-D-947166 Door Assembly<sup>8</sup>
- SM-D-947235 Mounting Bracket, Skid<sup>8</sup>
- SM-C-947237 Shock Mount<sup>8</sup>
- SM-D-947238 Skid Assembly<sup>8</sup>
- SM-B-947179 Bonding Procedure<sup>8</sup>
- SM-B-947180 Cleaning Procedure<sup>8</sup>
- SM-D-947181 Flatness and Squareness Measurements<sup>8</sup>
- SM-B-947184 Adhesive<sup>8</sup>
- SM-D-947186 Test Weight Installation<sup>8</sup>
- SM-C-947230 Shock Mount<sup>8</sup>
- 17-1-3274 Shelter, Electrical Equipment, S-280C/G (Shielded)<sup>8</sup>

**3. Terminology**

3.1 *Definitions:*

3.1.1 *delaminations*—for the purpose of this specification, a delamination is defined as the condition that exists within a shelter section or panel when two surfaces that once were bonded together are no longer bonded together. Delaminations may occur between any two bonded surfaces, examples include: separations between thermal barriers and members, between thermal barriers and skins, between members and core, or between skins and core. They may be the result of a poor quality bond or they could occur due to misuse or severe handling of the panels or the shelter after bonding. Test requirements of this specification shall not be construed as misuse or severe handling as these terms apply to the definition of delaminations (see 5.4).

3.1.2 *examination*—examination consists of simple, generally nondestructive determinations of compliance, without the use of special testing equipment.

3.1.3 *inspection*—inspection is the examination or testing, or both, of supplies to determine compliance with the applicable requirements. Sampling is an element of inspection.

3.1.4 *testing*—testing consists of determinations of compliance, using technical means.

3.1.5 *voids*—for the purpose of this specification, a void is defined as any unauthorized separation or space within a shelter panel or section, that is, any separation or space that is in conflict with the drawings or other contractual requirements. Voids range from gaps as wide as the space created by a missing piece of core material to as thin as a break in the continuity of material. Voids may be located solely within one type of material, such as a core material separation; they may exist between adjacent materials, such as unbonded core material; or they may be located between other parts within a panel, such as where a piece of material is missing, damaged, or undersized. Voids may have been created at the time of construction, such as where a part was omitted; or may be created at a later time, such as a core separation or delaminated skin (see 5.4).

NOTE 1—All other terminology related to this specification is defined in Terminology E 1749.

**4. Material Requirements**

4.1 *General*—Materials used in the construction of this item shall be in accordance with the following requirements:

4.2 *Core Material*—Core material density, compressive strength, shear strength, flammability, and water absorption properties shall be in accordance with Specification E 1730 and Drawings SC-B-595564 and SC-B-595565, as applicable (see 12.2.1, 10.1, Table 1, and Table 2).

4.3 *Adhesive*—The shear strength of the cured adhesive and its bond to aluminum shall be in accordance with requirements of Specification E 1794 and the Drawing SM-B-947184. This requirement shall apply to the low temperature, room temperature, and high temperature conditions and after the humidity exposure and salt spray exposure conditions required by SM-B-947184 (see 12.2.2, 12.2.3, 10.2, 10.2.2, Table 1, and Table 2).

4.4 *Sealer*—The shear strength of the cured sealer and its bond to aluminum shall be in accordance with the following (see 10.2, 10.2.2, Table 1, and Table 2):

4.4.1 *Low Temperature*—200 psi (1.4 MPa) when tested at  $-65 \pm 5^\circ\text{F}$  ( $-54 \pm 3^\circ\text{C}$ ) (see 12.2.2 and Table 2),

4.4.2 *Room Temperature*—200 psi (1.4 MPa) when tested at  $80 \pm 10^\circ\text{F}$  ( $27 \pm 6^\circ\text{C}$ ) (see 12.2.3 and Table 2),

**TABLE 1 First Article Specimens**

Inspection	Quantity	Requirements Subsection	Test Subsection
Core material:		4.2	10.1
Density	5 for every grade or type	4.2	10.1.1
Compressive strength	5 for every grade or type	4.2	10.1.2
Shear strength	5 for every grade or type	4.2	10.1.3
Flammability	5 for every grade or type	4.2	10.1.4
Water absorption	3 for every grade or type of urethane	4.2	10.1.5
Adhesive	50 coupons	4.3	10.2
Sealer	50 coupons	4.4	10.2
Shock mounts	SM-C-555515: 3 per -3 SM-C-947237: 3 each SM-C-947230: 3 each	4.5	10.3.1
Impact panel	1 from wall, 1 from floor	5.4.1	10.7
Hold down assembly	1 complete	9.2	10.32
Eye casting hardness	1 casting per SM-D-947143	7.5.2	10.24.2

**TABLE 2 In-Process Inspection**

Inspection	Requirements Subsection	Sampling Subsection	Test Subsection
Core material:	4.2	...	10.1
Density	4.2	12.2.1	10.1.1
Compressive strength	4.2	12.2.1	10.1.2
Shear strength	4.2	12.2.1	10.1.3
Adhesive:	4.3	...	10.2
Low temperature	4.3	12.2.2	10.2
Room temperature	4.3	12.2.3	10.2
High temperature	4.3	12.2.2	10.2
Sealer:	4.4	...	10.2
Low temperature	4.4.1	12.2.2	10.2
Room temperature	4.4.2	12.2.3	10.2
High temperature	4.4.3	12.2.2	10.2
Shock mounts	4.5	12.2.4	10.3.2
Cleaning	5.2	12.2.5	10.4
Welding	5.3	12.2.6	10.5
Lamination	5.4	12.2.7	10.6
Interchangeability	5.6	12.2.8	10.8
Riveting	5.7	12.2.9	10.9
Eye casting hardness	7.5.2	12.2.10	10.24.2
Construction tightness, shelter	8.2	12.2.11	10.10.1

**TABLE 3 Sequence of First Article Inspection**

Inspection	Requirements Subsection	Test Subsection
Cleaning	5.2	10.4
Welding	5.3	10.5
Lamination	5.4	10.6
Interchangeability	5.6	10.8
Riveting	5.7	10.9
Construction tightness	8.2	10.10
Finish	5.8	10.11
Marking	5.9	10.12
Dimensional	5.1	10.13
Visual and mechanical	9.3	10.14
Shelter weight	5.10	10.15
Door latch torque	8.3	10.16
Moisture resistance <sup>A</sup>	6.2	10.17
Temperature	6.3	10.18
Thermal differential	6.4	10.19
Rail transport	7.2.1	10.21
Drops	7.3	10.22
Construction tightness <sup>B,C</sup>	8.2	10.10.1
Towing, simulated	7.4	10.23
Eye pulls	7.5.1	10.24.1
Air transport, simulated	7.2.2	10.25
Static door load	7.6	10.26
Roof access steps	7.7	10.27
Light tightness	8.4	10.28
Electromagnetic interference suppression	8.5	10.29
Watertightness	8.6	10.30
Fording	8.7	10.31
Door latch torque (second time)	8.3	10.16

<sup>A</sup>First article specimen testing shall be completed no later than the end of this test (see 11.1.1).

<sup>B</sup>For correlation data purposes only. CTT test results are not to be used as accept/reject criteria for the drop test.

<sup>C</sup>Door portion and gasket portion only.

cleaned as required therein. After assembly the shelter shall be free from particles or scale, flux, excess adhesive, excess sealer, and other foreign material. The shelter shall be cleaned prior to application of finish.

**5.3 Welding**—All welds shall have thorough penetration and good fusion and shall be free from splatter, scabs, blisters, abnormal pock marks, cracks, voids, slag inclusions, and other defects. Welders shall be certified in accordance with MIL-STD-1595. Inert gas shielded arc welding shall be used for welding of aluminum in accordance with the drawings, except where resistance welding is specified (see 12.2.6, 10.5, Table 2, and Table 3).

**5.3.1 Arc Welding**—Except where required on the shelter drawings, welded joints shall not require grinding of the finished weld and shall not be ground. Welding to repair castings shall not be permitted.

**5.3.2 Resistance Welding**—Resistance welding shall be in accordance with Class B MIL-W-6858. Qualification of welding machines and certification of welding schedules in accordance with MIL-W-6858 is required prior to first article and production welding. Failure of any production specimen or any production part to meet the requirements of MIL-W-6858 shall be cause for rejection of the production quantity represented by that specimen or part.

**5.4 Lamination**—The roof, floor, door, and each wall of the shelter shall be bonded without voids or delaminations (see 3.1.1 and 3.1.5) to the inner and outer skins and other adjacent surfaces. No voids shall exist between the inner and outer surfaces of the panels due to foam breaks, misfits, or lack of adhesive. Bonding shall be in accordance with Practice E 1801

**4.4.3 High Temperature**—75 psi (75 KPa) when tested at  $200 + 0 - 5^{\circ}\text{F}$  ( $93 + 0 - 3^{\circ}\text{C}$ ) (see 12.2.2 and Table 2),

**4.4.4 Sealer Shear, Humidity Exposure**—The sealer and its bond to the aluminum shall withstand exposure to 95 % relative humidity  $\pm 5\%$  at  $160 \pm 5^{\circ}\text{F}$  ( $71 \pm 3^{\circ}\text{C}$ ) for fourteen days. After exposure the sealer shall have a minimum average shear strength of 75 psi (520 KPa) when tested at  $160 \pm 5^{\circ}\text{F}$  ( $71 \pm 3^{\circ}\text{C}$ ).

**4.4.5 Sealer Shear, Salt Spray Exposure**—The sealer and its bond to the aluminum shall withstand exposure to the salt spray test. Method 509.3 of MIL-STD-810E using a 20 % NaCl solution at  $95 \pm 5^{\circ}\text{F}$  ( $35 \pm 3^{\circ}\text{C}$ ) for fourteen days. After exposure the sealer shall have a minimum average shear strength of 200 psi (1.4 MPa) when tested at  $180 \pm 10^{\circ}\text{F}$  ( $27 \pm 6^{\circ}\text{C}$ ).

**4.5 Shock Mounts**—Shelter skid shock mounts shall be in accordance with Drawing SM-C-555515, SM-C-947237, and SM-C-947230 (see 12.2.4, 10.3, 10.3.1, 10.3.2, Table 1, and Table 3).

## 5. Construction Requirements

**5.1 General**—The electromagnetic protected shelter shall be constructed in accordance with Drawing 17-1-3274 and all subsidiary drawings and parts lists pertaining thereto and as specified herein.

**5.2 Cleaning**—See 12.2.5, 10.4, Table 2, and Table 3.

**5.2.1 Welding and Bonding**—All aluminum parts to be welded or bonded shall be cleaned in accordance with Practice E 864 and Drawing SM-B-947180. The inspection and records maintenance requirements of Practice E 864 and SM-B-947180 shall be met. Arc welded assemblies shall be cleaned to remove any scale, oxidation products, and excess flux. Any acid used in cleaning shall be completely neutralized and removed.

**5.2.2 Other**—All aluminum parts to be sealed at a sub-assembly or at final assembly shall be cleaned in accordance with Practice E 864 and SM-B-947180. Part drawings which cite a specific finish in accordance with MIL-F-14072 shall be

and SM-B-947179 (see 12.2.7, 10.6, Table 2, and Table 3).

**5.4.1 Impact Resistance**—The floor, door, and each wall of the shelter shall be capable of withstanding impact by a foreign object. To determine compliance with this requirement, specimens shall be fabricated and tested in accordance with 10.7. Each specimen shall not suffer rupture or fracture of either of the skins and shall not result in denting of the lower skin (see Table 1 and Table 4).

**5.5 Vapor Seal**—Except for the breather holes required for the construction tightness test, and in accordance with the shelter drawings, the inner and outer skins and all joints shall be sealed to provide a vapor barrier against the entrance of moisture to the core material and to the interior of the shelter

**TABLE 4 Group C Inspection**

Inspection	Requirements Subsection	Sampling Subsection	Test Subsection
Drops	7.3	12.3.3.1	10.22
Construction tightness <sup>A,B</sup>	8.2	...	10.10
Watertightness <sup>C</sup>	8.6	...	10.30
Fording <sup>C</sup>	8.7	...	10.31
Door latch torque <sup>C</sup>	8.3	...	10.16
EMI suppression	8.5	12.3.3.2	10.29
Watertightness <sup>D,E,F</sup>	8.6	...	10.30
Fording <sup>D,E</sup>	8.7	...	10.31
Door latch torque <sup>D,E</sup>	8.3	...	10.16
Hold down assembly	9.2	12.3.3.3	10.32
Core material:	...	...	...
Flammability	4.2	12.3.3.4	10.1.4
Water absorption	4.2	12.3.3.4	10.1.5
Adhesive	...	...	...
Humidity exposure	4.3	12.3.3.4	10.2
Salt spray exposure	4.3	12.3.3.4	10.2
Sealer	...	...	...
Humidity exposure	4.4.4	12.3.3.4	10.2
Salt spray exposure	4.4.5	12.3.3.4	10.2
Shock mounts, complete	4.5	12.3.3.4	10.3.1
Impact panel	5.4.1	12.3.3.4	10.7
Environmentals: <sup>A</sup>	...	12.3.3.4	...
Moisture resistance <sup>E</sup>	6.2	...	10.17
Temperature <sup>E</sup>	6.3	...	10.18
Thermal differential <sup>F</sup>	6.4	...	10.19
EMI suppression <sup>G,H</sup>	8.5	...	10.29
Watertightness <sup>E,G</sup>	8.6	...	10.30
Fording <sup>E,G</sup>	8.7	...	10.31
Door latch torque <sup>E,G</sup>	8.3	...	10.16
Rail transport <sup>E</sup>	7.2.1	...	10.21
Drops <sup>E,I</sup>	7.3	...	10.22
Construction tightness <sup>D,E,J</sup>	8.2	...	10.10
EMI suppression <sup>E,J</sup>	8.5	...	10.29
Watertightness <sup>E</sup>	8.6	...	10.30
Fording <sup>E</sup>	8.7	...	10.31
Door latch torque <sup>E</sup>	8.3	...	10.16
Towing, simulated	7.4	12.3.3.4	10.23
Air transport, simulated	7.2.2	12.3.3.4	10.25

<sup>A</sup>These inspections shall be performed on the same (serial number) shelter.

<sup>B</sup>Door portion and gasket portion only.

<sup>C</sup>If the EMI suppression test is to follow the drop test on the same shelter, these tests shall be done after EMI.

<sup>D</sup>To be performed only if EMI test followed drop test on the same shelter or if adjustment to gasket compression was necessary to satisfy EMI suppression requirements.

<sup>E</sup>Modification Kit MK-1079/G to remain installed during these tests.

<sup>F</sup>If shelter was not drop tested prior to EMI testing, this watertightness test shall use only the nine nozzles located at the door end of the shelter.

<sup>G</sup>If the transport test is to follow the environmental tests on the same shelter these tests shall be done after the drop test.

<sup>H</sup>This inspection may also satisfy sampling for EMI suppression in accordance with 12.3.3.2.

<sup>I</sup>This inspection may also satisfy sampling for drop test in accordance with 12.3.3.1.

<sup>J</sup>For correlation data purposes only. CTT test results are not to be used as accept/reject criteria for the drop test.

(see 5.11, 10.30, and 10.31). (See Practice E 1773).

**5.6 Interchangeability**—Like units, subassemblies, assemblies, and replaceable parts shall be physically and functionally interchangeable without modification of the items or the shelter. Individual items shall not be hand-picked for fit or performance. Reliance shall not be placed on any dimension, rating, characteristic, etc. not specified on the drawings. To determine compliance with this requirement, the items listed in 10.8 shall be measured and shall be in accordance with the dimensions and tolerances specified on the applicable drawing (see 12.2.8, Table 2, and Table 3).

**5.7 Riveting**—No more than one rivet or rivnut in ten and no more than two adjacent rivets or rivnuts shall exhibit any of the defects specified below (see 12.2.9, 10.9, Table 2, and Table 3).

**5.7.1 Looseness**—There shall be no evidence of looseness parallel to the plane of the mating surfaces due to oversized holes or looseness perpendicular to the plane of the mating surfaces due to rivets or rivnuts not being tightly sealed.

**5.7.2 Heads**—Rivet and rivnut heads shall not be cut, marred, chipped, eccentric, distorted, or otherwise mutilated. Countersunk rivets and rivnuts shall not project above or below the mating surface more than 15 % of the mating material thickness (see 10.9).

**5.7.3 Mating Surface and Materials**—The mating surface shall not be marred or indented due to rivet or rivnut installation, nor shall there be any distortion or warpage of the mating materials. There shall be no foreign material between riveted surfaces. The term foreign material does not include material required by and allied in accordance with the shelter drawings.

**5.8 Finish**—The shelter shall be finished in accordance with the drawings and the paint finishes requirements of MIL-F-14072 (see 10.11, 10.14, and Table 3).

**5.9 Marking**—Marking shall be in accordance with the drawings and MIL-M-13231. Classification of defects in MIL-M-13231 is applicable. Serial numbers shall be marked in accordance with the drawings on the shelter and on the nameplate in the space provided (see 10.12, 10.14, and Table 3).

**5.9.1 Facsimiles**—When specified (see 15.1.4), the contractor shall provide facsimiles of the nameplate and all data and instruction plates required by DL-SM-D-947080 (see 15.1.3). Each facsimile shall be in accordance with its drawing and shall include any and all information required to be inserted, except shelter serial number. Artwork shall be of a quality at least comparable to the drawing (see 10.14).

**5.10 Shelter Weight**—The gross weight of the shelter, excluding the hold down assembly, SC-D-36423, shall be as follows (see 10.15, Table 2, and Table 5):

5.10.1 1400 ± 30 lb (636 ± 14 kg) without MK-1079( )/G installed, and

5.10.2 1410 ± 30 lb (640 ± 14 kg) with MK-1079( )/G installed.

**5.11 Service Integrity**—Unless otherwise specified, all inspections required herein shall not result in any of the defects listed below. This service integrity requirement shall apply to the shelter both with and without Modification Kit, RFI, MK-1079( )/G installed, as required by the individual inspections specified herein, (see 6.1, 7.1, 8.1, 10.0, 10.17, 10.18,

**TABLE 5 Group A Inspection**

Inspection	Requirements Subsection	Test Subsection	AQL %	
			Major	Minor
Construction tightness	8.2	10.10	...	...
Shelter portion (audit only)	8.2	10.10.1	1.00	...
Door portion	8.2	10.10.2	1.00	...
Gasket portion	8.2	10.10.3	1.00	...
Visual and mechanical	9.3	10.14	1.00	4.00
Dimensional	5.1	10.13	1.00	...
Door latch torque <sup>A</sup>	8.3	10.16	1.00	...
Shelter weight	5.10	10.15	1.00	...

<sup>A</sup>Door latch torque to be repeated during the final cursory visual mechanical inspection.

10.19.1, 10.21, 10.21.1, 10.22.2, 10.23, 10.24.1, 10.25, 10.26, and 10.27).

5.11.1 There shall be no delamination, buckling, splitting, or other deformation or structural weakening of the shelter.

5.11.2 The vapor seal of 5.5 shall remain intact at all cross-sectional openings of the shelter and at all fillets and fasteners.

5.11.3 Brackets, lugs, flanges, inserts, bolts and any other mounting arrangement shall securely retain test loads, the door, and all hardware.

5.11.4 There shall be no corrosion of any parts.

5.11.5 There shall be no growth of the core material.

5.11.6 Unless otherwise specified, all shelter dimensions shall remain in accordance with the drawings.

5.11.7 Any deformation of any mounting arrangement shall be within drawing tolerances and shall not cause degradation of its retaining ability or of specified shelter performance.

5.11.8 The door and the emergency exit cover shall open and close to their full extent without binding in the hinge(s) or interfering against any portion of the door or cover jamb or gasket bearing areas.

5.11.9 There shall be no malfunction of the door latch mechanism.

5.11.10 There shall be no binding in the door brace pivot points or interference between brace components.

5.11.11 When a tiedown is required, it shall not be damaged as a result of the test.

5.12 *Construction Tightness Preconditioning*—Prior to submission for the specified qualification inspection, each shelter shall show no evidence of air leakage through sealed seams, joints, rivets, mounting bolts, etc., when tested and corrected in accordance with 10.10.1.

## 6. Environmental Requirements

6.1 *General*—The shelter shall meet the following environmental service conditions. Where a test is referenced, meeting the test shall be considered as compliance with the requirement (see 5.11).

6.2 *Moisture Resistance*—Daily exposure up to 97 % relative humidity for 20 h and exposure at 100 % relative humidity with condensation for 4 h (see 10.17 and Table 3).

6.3 *Temperature*—The shelter shall withstand rapid temperature changes and exposure to the following (see 10.18 and Table 3):

6.3.1 *Operating*—Ambient temperature in the range of  $-65$  to  $+125^{\circ}\text{F}$  ( $-54$  to  $52^{\circ}\text{C}$ ) plus a solar load such that the outside

skin reaches a minimum temperature of  $200^{\circ}\text{F}$  ( $93^{\circ}\text{C}$ ). Exposure at the high extreme is not to exceed 4 h and at the low temperature extreme is not to exceed 72 h at any one time.

6.3.2 *Nonoperating*—Exposure in the range of  $-80$  to  $+160^{\circ}\text{F}$  ( $-62$  to  $+71^{\circ}\text{C}$ ). Exposure at the high temperature extreme is not to exceed 4 h and at the low temperature extreme is not to exceed 24 h at any one time.

6.4 *Thermal Differential*—See 10.19 and Table 2.

6.4.1 *Thermal Deformation*—The shelter shall withstand exposure to a temperature differential of  $100^{\circ}\text{F}$  between the inside and outside of the shelter (see 10.19.1).

6.4.2 *Heat Transfer*—When specified (see 15.1.5), the overall coefficient of heat transfer of the shelter shall not exceed 0.28 British Thermal Units (BTUs) per hour per square foot per degree Fahrenheit (1.6 Watts per square metre per degree Kelvin). This overall coefficient shall apply to the shelter with the door and the emergency exit cover closed and with no additional thermal sealing (see 10.19.2).

## 7. Structural Integrity Requirements

7.1 *General*—The shelter shall be capable of complying with the following requirements. Unless otherwise specified when a payload is required, the shelter shall be loaded with 5000 lb in accordance with DL-SM-B-947186. Where a test is referenced, meeting the test shall be considered as compliance with the requirement (see 5.11, 10.21, 10.22, and 10.23).

7.2 *Transportability*—The shelter, with payload, shall be capable of being picked up by a crane using the hold down assembly, SC-D-36423, transported while suspended from the crane, and lowered to any predetermined point on the ground. The shelter shall also be capable of being transported as follows:

7.2.1 *Rail Transport*—The shelter, with payload, shall be capable of being loaded and braced on a flatcar for shipment by rail (see 10.21, Table 2, and Table 5).

7.2.2 *Air Transport*—The shelter shall have adequate strength to secure 5000 lb of equipment mounted in the shelter when exposed to 3.0 G's acceleration with the shelter suspended by its lifting eyes (see 10.25, Table 3, and Table 5).

7.3 *Drops, Flat and Rotational*—The shelter, with a 5000 lb (2270 kg) payload, shall be capable of withstanding drops of 18 in. (460 mm) onto concrete during handling. After all drops of 10.22, the inside dimensions of the shelter shall remain in accordance with Drawing SM-D-947080. There shall be no permanent deformation, buckling, delamination (see 3.1.5), sealer separation, or structural weakness to any part of the shelter, except that deformation in the skids and skid mounting brackets shall not exceed  $\frac{1}{4}$  in. (6 mm), and a quarter moon shaped (3 by 13 in. (75 by 330 mm)) delamination (bulge) that appears on the interior front panel along the floor between the two center members shall not be considered cause for failure. The door and cover shall open and close to the full extent specified on the applicable drawing on DL-SM-D-947080 without binding in the hinge(s) or interfering against any portion of the jamb or bearing areas, or both, (see 12.3.3.1, 10.22.1, 10.22.2, Table 3, and Table 6).

7.4 *Towing, Simulated*—The shelter shall be capable of withstanding a 3000 lb (1360 kg) shear force applied to the plane of the skid attachment without damage to any part of the

**TABLE 6 Group B Inspection**

Inspection	Requirements Subsection	Test Subsection	AQL %
Finish	5.8	10.11	6.5
Eye pulls	7.5.1	10.24.1	6.5
Static door load	7.6	10.26	6.5
Roof access steps	7.7	10.27	6.5
Construction tightness <sup>A</sup>	8.2	10.10	1.0
Light tightness	8.4	10.28	6.5

<sup>A</sup>Door portion and gasket portion only.

shelter, skid assemblies or skid mounting brackets (see 13.23, Table 3, and Table 5).

7.5 *Lifting and Towing Eyes*—See 13.24.

7.5.1 *Eye Pulls*—Each lifting and towing eye assembly, installed on the shelter, shall be capable of withstanding loads in accordance with 13.24.1 with no damage to the eye assemblies, or shelter (see Table 3 and Table 6).

7.5.2 *Eye Casting Hardness*—Each lifting and towing eye casting in accordance with SM-D-947143 shall be properly aged and hardened to a hardness of 75 Brinell Standard Type (10 mm ball, 500 kg load) prior to machining (see 12.2.10, 10.24.2, Table 1, and Table 3).

7.6 *Static Door Load*—The door, door frame, and door hardware shall be capable of supporting a vertical load of 200 lb (90 kg) applied in accordance with 10.26. There shall be no damage and the door shall seal properly, as determined by inspecting in accordance with 10.10.3 (see Table 3 and Table 6).

7.7 *Roof Access Steps*—Each roof access step installed on the shelter shall be capable of supporting a vertical load of 400 lb (180 kg) applied in accordance with 10.27. There shall be no damage and the step shall open and close without binding (see Table 3 and Table 6).

## 8. Tightness Requirements

8.1 *General*—The shelter shall be capable of meeting the following tightness requirements. Except for 8.5, these requirements apply both with and without MK-1079/G installed (see 5.11).

8.2 *Construction Tightness*—The shelter shall be airtight to the extent that it shall be capable of achieving and maintaining a pressurized state without leakage when tested in accordance with 10.10 (see 12.2.11, Table 2, Table 3, Table 4, and Table 4).

8.3 *Door Latch Torque*—When tested in accordance with 10.16, the door latch torque shall not exceed the following (see Table 3, Table 5, and Table 6):

8.3.1 15 ft-lbf maximum when MK-1079/G is not installed, and

8.3.2 30 ft-lbf maximum when MK-1079/G is installed.

8.4 *Light Tightness*—No direct rays of light shall be visible through the intake louver assembly when tested in accordance with 10.28 and viewed by an observer from the darkened shelter interior (see Table 3 and Table 6).

8.5 *Electromagnetic Interference (EMI) Suppression*—The shelter shall be capable of being shielded from electromagnetic interference by the installation of Modification Kit, Radio Frequency Interference, MK-1079/G in accordance with DL-SC-A-621051 and with no other modification. Shielding shall provide a minimum attenuation of radiated and induced EMI

fields as specified in Specification E 1925 within the frequency range of 100 kHz to 10 GHz when tested in accordance with 10.29. Should a shelter subjected to the EMI test fail to pass, another shelter from the same lot shall be subjected to the EMI test (see 12.3.3.2, 10.29, Table 3, and Table 5).

8.6 *Water Tightness*—The shelter shall be watertight when tested and inspected in accordance with 10.30. This requirement shall be met without the use of any external or internal sealing, caulking, taping, etc., not specified on the drawings (see Table 3 and Table 5).

8.7 *Fording*—The shelter shall be capable of being immersed in water to a depth of 21 in. (530 mm) measured from the bottom of the shelter skids. There shall be no leakage or damage to the structure or finish when tested and inspected in accordance with 10.31. This requirement shall be met without the use of any external or internal sealing, caulking, taping, etc. not specified on the drawings and without the use of a special fording kit (see Table 3 and Table 4).

## 9. Other Requirements

9.1 *First Article*—When specified (see 15.1.2), the contractor shall furnish sample items for first article inspection and approval (see 11.1).

9.2 *Hold Down Assembly*—A combination lift and tiedown device shall be provided as part of each shelter. This device will be used for lifting the shelter and for tying down the shelter in military trucks. The device shall be in accordance with Drawing SC-D-36423, Hold Down Assembly. Each cable assembly in accordance with Drawing SC-C-36424 shall be capable of withstanding a tensile load of 14000 lb (6350 kg) as specified on SC-C-36424 (see 12.3.3.3, 10.25, 10.32, Table 3, and Table 4).

9.3 *Workmanship*—The shelter shall be manufactured with the degree of workmanship normally considered appropriate for each of the areas listed under Section 5 (see 10.14, Table 3, and Table 5).

## 10. Tests Required

10.1 *Core Material*—Subject core material specimens to the following tests. For each test a set of five specimens is required for each type or grade of core material used in the shelter. Fabricate specimens from actual shelter core material pieces randomly selected from production core material parts. Specimen dimensions shall be within  $\pm 0.015$  in ( $\pm 0.4$  mm). Except for flammability, the requirements of 4.2 shall be met by the average of the specimen results, with the lowest result no less than 90 % of the required value (see 12.2.1, Table 1, and Table 2).

10.1.1 *Density*—Test five specimens, each 2 by 3 by 3 in. (50 by 75 by 75 mm), in accordance with Test Method D 1622 (see Table 1 and Table 2).

10.1.2 *Compressive Strength*—Test five specimens, each 2 by 3 by 3 in. (50 by 75 by 75 mm), in accordance with Test Method D 1621, Procedure A (see Table 1 and Table 2).

10.1.3 *Shear Strength*—Test five specimens, each ½ by 1½ by 6 in. (13 by 38 by 152 mm), in accordance with Test Method C 273, except apply the load at a constant rate such that the maximum load will occur in 1 min or more (see Table 1 and Table 2).

10.1.4 *Flammability*—Determine flame resistance of the five specimens, each ½ by 1½ by 7 in. (13 by 38 by 178 mm), (see Table 1) in accordance with FAR 25.853, Appendix F. The average extinguish time shall not exceed 15 s, and the average burn distance shall not exceed 6 in. (150 mm).

10.1.5 *Water Absorption*—Test three specimens, each 6 by 6 by 3 in. (150 by 150 by 75 mm), in accordance with Test Method D 2842 with the following changes: weigh each specimen as it is first submerged; also weigh the weighing jig shall at this time; for the final weight, weigh the specimens and remove from the water in reverse order; calculate the water absorption as follows:

10.2 *Coupon Specimens*—Coupon specimens for both adhesive and sealer tests shall be lap joints fabricated in accordance with SM-B-947184. Five coupons are required for each of the five test conditions. For first article inspection, ten coupons are required for each of the five test conditions (see 4.3, 4.4, 12.2.2, 12.2.3, Table 1, Table 2, and Table 4).

10.2.1 *Compatibility of Fabrication and Cure*—Verify two or more part mixes of adhesive as being in accordance with SM-B-947184 before coupons are fabricated. Verify two or more part mixes of sealer as being in accordance with SM-B-947184 before coupons are fabricated. Calibrate automatic dispensing machines, when used to mix and deliver two or more part adhesive or sealer, at least once every 4 h. Fabricate coupon specimens and cure using materials, processes, and conditioners compatible with those used on panels and shelters, including:

10.2.1.1 Same batch and type of material,

10.2.1.2 Surface conditions of and method of preparing materials to be bonded or sealed,

10.2.1.3 Time elapsed between application of adhesive to the first panel in a lot of panels and application of temperature and pressure to the lot of panels,

10.2.1.4 Time, temperature, and pressure of cure. Cure sealer coupons at a pressure of  $5 \pm \frac{1}{2}$  psi ( $34 \pm 3$  KPa), and

10.2.1.5 Minimum cure time before handling.

10.2.2 *Shear Tests*—Test coupons at the specified temperature after being subjected to the specified exposure, if applicable. Stabilize the temperature of the coupons at the specified level and measure by a thermocouple attached to the coupon over the lap joint. The thermocouple shall not be attached on that side of the lap joint closest to the heat or cold source nor shall the method of attachment impair the application or measurement of the shear force in any way. Apply the shear force to destruction. Set rate of application of force under no-load conditions and be constant at 1 in./min  $\pm$  2 s (25 mm/min  $\pm$  2 s). Meet the requirements of 4.3 for adhesive and 4.4, with subparagraphs, for sealer by the average of the coupon results, with the lowest result no less than 90 % of the required value for adhesive and 70 % of the required value for sealer. Failure to meet these requirements shall be cause for rejection of all panels and shelters fabricated using that production quantity of adhesive or sealer represented by that failed coupon or average.

10.3 *Shock Mounts*—Determine compliance with 4.5 by the following inspections:

10.3.1 *Complete Inspection*—Inspect the shock mount ma-

terial by subjecting it to all tests specified on Drawing SM-C-555515, SM-C-947237, or SM-C-947230. Fabricate where possible, test specimens from actual shock mounts furnished for the shelter. Subject three shock mounts in accordance with each shock mount drawing to the depression-deflection test of its respective drawing. The requirements of 4.5 shall be met (see Table 1).

10.3.2 *Abbreviated Inspection*—Inspect the shock mounts by subjecting them to the hardness, resilience, and depression-deflection tests in accordance with SM-C-555515, SM-C-947237, and SM-C-947230. The requirements of 4.5 shall be met (see 12.2.4 and Table 2).

10.4 *Cleaning*—Inspection of the cleaning process shall be in accordance with Practice E 864 and SM-B-947180. Any noncompliance shall require recleaning of the parts processed since the last acceptable inspection. The requirements of 5.2, with subsections, shall be met (see 12.2.5, Table 2, and Table 3).

10.5 *Welding*—Visually inspect arc welding in accordance with the requirements of maintenance sampling for production of MIL-W-8604. For resistance welding, fabrication and inspection of production specimens and inspection of production parts shall be in accordance with MIL-W-6858. The requirements of 5.3, with subsections, shall be met (see 12.2.6, Table 2, and Table 3).

10.6 *Lamination*—Inspect panels and shelters for lamination using a tap hammer in accordance with Fig. 1. Accomplish inspection by tapping the panel skins with the spherical end of the hammer. Use the flat end of the hammer for tapping into corners. Tapping force shall be approximately equal to that produced when the head is raised approximately 1 in. (25 mm) above the panel and allowed to fall against the panel and with the center of arc 12 in. (300 mm) from the head. A hammer blow on a laminated area produces a “solid” or “firm” or “ringing” sound whereas a delaminated area produces a “deadened” or “hollow” or “metallic slap” sound. The extent of interrogation of each side of each panel shall be at least four hammer impacts per square foot of panel area between members and at least four hammer impacts per square foot over members on the interior side of the panel. Once a suspect area has been located, interrogate said area in detail by at least one hammer impact per inch in all directions. Mark the delamination boundaries as the point of acoustic change (“deadening”) plus ½ in. (6 mm). The requirements of 5.4 shall be met (see 12.2.7, Table 2, and Table 3).

10.7 *Impact Resistance*—Fabricate an impact resistance specimen in accordance with Fig. 2. The specimen shall contain only one continuous piece of core material bonded with adhesive, without voids or delaminations, to two aluminum skins. For testing, support the specimen along its four edges by a framework backed by concrete. The framework shall be made of four pieces of 2 by 4 in. (50 by 100 mm) (nominal) lumber. Rigidly bolt the frame together to form a square 24 in. (610 mm) on a side (outside dimension) and 4 in. (100 mm) high. Rest the frame on the 2 in. (50 mm) face. Bolt the specimen to the frame with two ¼ in. (6 mm) diameter bolts per edge. Leave a gap of 0.010 in. (0.3 mm) under each bolt. Then impact the specimen with a 70 lb (32 kg) steel cylinder 3 in.

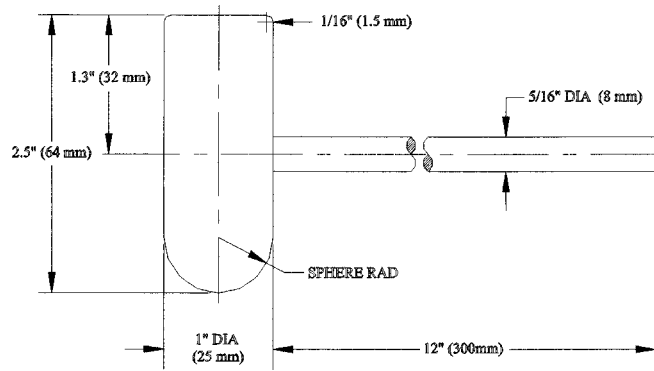

NOTE 1—Material—Aluminum 6061-T6 or equivalent.  
 NOTE 2—Tolerance— $\pm 1/32$  in (1 mm).

FIG. 1 Tap Hammer

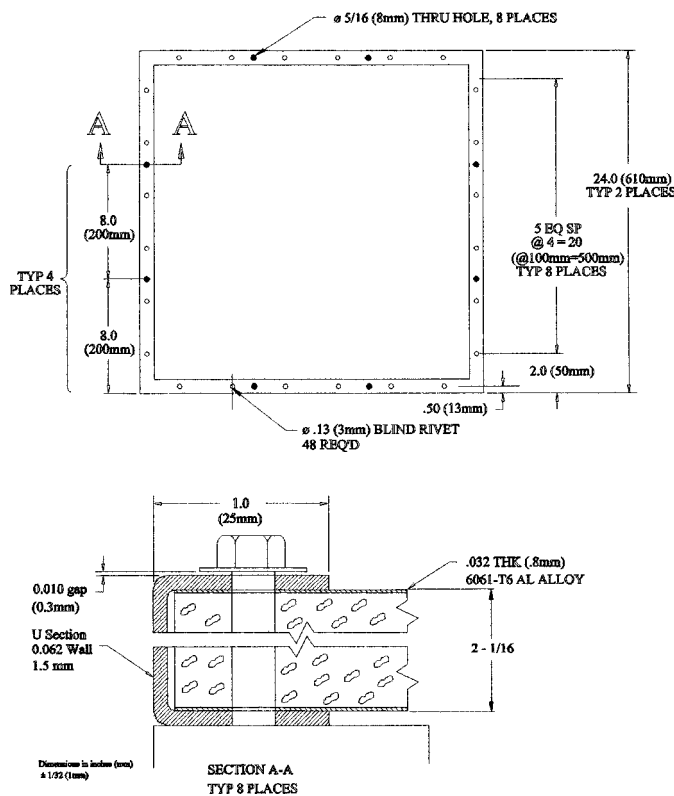

FIG. 2 Impact Resistance Specimen

(75 mm) in diameter and hemispherical at one end. Vertically drop the cylinder 30 in. (762 mm) so that the hemispherical end of the cylinder strikes the center of one skin of the specimen on a horizontal plane. After impact, the specimen shall meet the requirements of 5.4.1. Then cut open the specimen and examine for conformance with Fig. 2 and the requirements specified herein (see Table 1).

10.8 *Interchangeability*—To determine compliance with the interchangeability requirement of 5.6, measure the following dimensions and characteristics and check in process (see 12.2.8, Table 2, and Table 3):

10.8.1 Overall dimensions, squareness, parallelism, flushness of the corner miter joints, and flatness at the gasket seating and contact surfaces of the items listed below. Inspect flatness

by measuring the flatness of the four sides and the flatness at the corners along the diagonals using a straight edge with a center rest point.

10.8.1.1 Door in accordance with SM-D-947166,

10.8.1.2 Emergency exit opening in the door in accordance with SM-D-947166,

10.8.1.3 Emergency exit panel in accordance with SM-D-450462, and

10.8.1.4 Emergency exit cover in accordance with SM-D-595509.

10.8.2 Overall dimensions, squareness, parallelism, and location of mounting holes of the louver assembly in accordance with SM-D-615264.



10.8.3 Dimensions of air filter in accordance with SM-C-450466.

10.8.4 Locations of center marks for mounting members in accordance with SM-D-947083, SM-D-947084, SM-D-947085, SM-D-947081, and SM-D-947082.

10.8.5 Mounting dimensions of hinges in accordance with SM-D-947080 and of latches in accordance with SM-D-947166.

10.8.6 Overall dimensions of skids and location of mounting holes in accordance with SM-D-947238, SM-D-947080, and SM-D-947235.

10.8.7 Overall dimensions and location of mounting holes of the lifting eyes in accordance with SM-D-947141 and of the towing eyes in accordance with SM-D-947142.

10.8.8 Check padlocks and keys for proper operation. Check four keys against three different padlocks.

10.9 *Riveting*—Visually examine rivets and rivnuts to determine compliance with 5.7. Remove countersunk rivet and rivnut heads that appear to project above or below the mating surface and replace after the noncompliance has been recorded. All replacement rivets or rivnuts shall be subjected to this inspection (see 12.2.9, Table 2, and Table 3).

10.10 *Construction Tightness*—Perform this test in three portions as follows: shelter, door, and gasket. Conduct all portions indoors and in still air. Correct any leaks found during any portion of this test before proceeding with the next portion of this test (see 8.2, Table 3, Table 4, and Table 5).

10.10.1 *Shelter Portion*—Place the shelter in a position that allows access to all exterior joints and fasteners on all surfaces and test as follows (see 12.2.11, Table 2, and Table 5).

10.10.1.1 *Assembled Condition*—Use no sealant, caulking, tape, etc., on the shelter except as detailed on the drawings. Complete the shelter except the skid mounting bracket (SM-D-947235) and related shims and the latch keepers (SC-C-200154) and related shims shall not be installed. The door assembly (SM-D-947166) need not be installed. Install the rivnuts used to connect these parts, however, in the shelter. The shelter exterior need not be painted before the test. For Group A Audit testing, completely assemble and finish the shelter.

10.10.1.2 *Test Fixtures and Equipment*—This test requires the use of the following:

10.10.1.3 Door fixture in accordance with drawing SM-D-781242,

10.10.1.4 Drain fixture in accordance with drawing SM-D-781243,

10.10.1.5 U-tube manometer with graduations of 0.1 in. of water or less,

10.10.1.6 Air flow regulating device,

10.10.1.7 Temperature potentiometer and two thermocouples, with a combined accuracy of  $\pm 0.2^\circ\text{F}$  ( $\pm 0.1^\circ\text{C}$ ) or less,

10.10.1.8 Air flow measuring device with graduations of 0.05 SCFM (25  $\text{cm}^3/\text{s}$ ) (standard cubic feet per minute) (SCMM) or less and with an accuracy of 0.05 SCFM (25  $\text{cm}^3/\text{s}$ ) or less, and

10.10.1.9 Miscellaneous rubber tubing and fittings, as required.

10.10.1.10 *Performance of Test*—Install or assemble, or

both, test fixtures and equipment as required by drawing SM-D-781244. Testing shall then proceed as follows:

10.10.1.11 Introduce clean, dry air into the shelter through the drain fixture. The temperature differential between the pressurized air inside the shelter and the air outside the shelter shall not exceed  $2.0^\circ\text{F}$  ( $1.0^\circ\text{C}$ ). Testing shall not proceed until the temperatures have stabilized within that limit. Achieve and maintain an interior differential pressure of  $12.0 \pm 0.3$  in. of water (3KPa  $\pm$  75 Pa). The airflow required to maintain this pressure shall not exceed 1.5 SCFM (700  $\text{cm}^3/\text{s}$ ). If the flow exceeds this limit the shelter shall be considered as having failed this test. Perform the inspection of 10.10.1.4, regardless of the pressure and SCFM achieved, to locate the leak(s). Rework shall be accomplished. Then reinspect the reworked area(s) in accordance with 10.10.

10.10.1.12 While the interior differential pressure is maintained, paint every joint, rivet, rivnut, bolt and any other area on the shelter exterior where two places interface with a soap and water solution. There shall be no leaks, as evidenced by bubbling or spurting. If there is a leak(s), rework shall be accomplished. Detection and rework of leak(s) at this stage shall not be considered as a failure of the construction tightness test unless said test was being performed in compliance with the Group A Audit requirement of Table 5. In any event, reinspect the reworked area(s) in accordance with 10.10 after rework.

10.10.1.13 Do not perform inspection of the skid attachment areas on Group A Audit units. Also, do not remove latch keepers.

10.10.2 *Door Portion*—After successful completion of the shelter portion in accordance with 10.10.1, test the shelter as follows (see Table 5):

10.10.2.1 *Assembled Conditions*—Use no sealant caulking, tape, etc., on the doors except as detailed on the drawings. Completely assemble the doors and louver cover with all hardware and gaskets, install on the shelter, close, and latch. Meet the requirements of Note 7 on Drawing SM-D-947080 and the tightening instruction on Sheet 2 of Drawing SM-D-450462 before proceeding with this test.

10.10.2.2 *Test Fixtures and Equipment*—This test requires the use of the items in 10.10.1.4-10.10.1.8.

10.10.2.3 *Performance of Test*—Install or assemble, or both, the test fixture and equipment as required by Drawing SM-D-781244. Testing shall then proceed as follows:

10.10.2.4 Introduce clean, dry air into the shelter through the drain fixture. The temperature differential between the pressurized air inside the shelter and the air outside the shelter shall not exceed  $2.0^\circ\text{F}$  ( $1.0^\circ\text{C}$ ). Do not proceed testing until the temperatures have stabilized within that limit. Achieve and maintain an interior differential pressure of  $6.0 \pm 0.3$  in. of water (1.5 KPa  $\pm$  75 Pa). If the shelter is unable to achieve and maintain that pressure consider the shelter as having failed this test. Perform the inspection of 10.10.2.5 regardless of the pressure achieved, to locate the leak(s). Rework shall be accomplished. Then reinspect the reworked area(s) in accordance with 10.10.2.

10.10.2.5 While the interior differential pressure is maintained, paint every joint, rivet, rivnut, bolt, hinge assembly, and

any other area on the exterior of the doors and louver cover where two pieces interface with a soap solution, except the gaskets and their bearing surface where air will be allowed to blow through. There shall be no leaks as evidenced by bubbling or spurting. If there is a leak(s), rework shall be accomplished. Detection and rework of leak(s) at this stage shall not be considered as a failure of the construction tightness test unless said test was being performed in compliance with the Group A Audit requirement of Table 5. In any event, reinspect the reworked area(s) in accordance with 10.10.2 after rework.

10.10.3 *Gasket Portion*—After successful completion of the door portion in accordance with 10.10.2, test the gasket sealing on the door and the emergency exit cover as follows (see 7.6 and Table 5):

10.10.3.1 *Assembled Condition*—As required in 10.10.2.1.

10.10.3.2 *Test Equipment*—This test requires the use of a piece of paper 0.0035 in. (0.09 mm) maximum thickness by 2½ in. (64 mm) wide.

10.10.3.3 *Performance of Test*—Inspect the entire horizontal portion of the top and bottom of the door and louver cover (except for the top of the louver cover), near each corner (position paper edge ½ in. (13 mm) from each corner) and two places along each side at approximately ⅓ and ⅔ the height of the door, as follows.

NOTE 2—Total inspection locations are 14 for the door and 11 for the louver cover.

10.10.3.4 Close the door or cover so that the paper is between the weather gasket and its bearing surface (but not under the RFI gasket if so equipped). Withdraw the paper while the door or cover is closed. The absence of any resistance to the withdrawal indicates that the gasket is not touching its bearing surface. If this condition is found, increase the gasket compression in the appropriate manner and repeat this inspection. If a gasket(s) is unable to meet this inspection requirement without exceeding the requirements stated in 10.10.3.1 consider the shelter as having failed this test. Rework shall be accomplished. Then reinspect the reworked area(s) in accordance with 10.10.2 and 10.10.3.

10.10.4 *Construction Tightness Test Records*—The contractor shall maintain records of all construction tightness tests performed, including any reinspections and tests performed in compliance with Group A Audit requirement of 12.3.1. Records shall contain, as a minimum, the shelter serial number and the following:

10.10.4.1 *Shelter Portion:*

10.10.4.2 An indication of compliance with 10.10.1.1 and Drawing SM-D-781244,

10.10.4.3 Temperature differential, interior differential pressure, and airflow in accordance with 10.10.1.11,

10.10.4.4 If any leak was found,

10.10.4.5 Date inspection was performed,

10.10.4.6 A statement that rework was performed, if applicable, and

10.10.4.7 Date reinspection was performed, if applicable.

10.10.4.8 *Door Portion:*

10.10.4.9 An indication of compliance with 10.10.2.1 and Drawing SM-D-781244,

10.10.4.10 Temperature differential and interior differential

pressure in accordance with 10.10.1.11,

10.10.4.11 If any leak was found,

10.10.4.12 Date inspection was performed,

10.10.4.13 A statement that rework was performed, if applicable, and

10.10.4.14 Date reinspection was performed, if applicable.

10.10.4.15 *Gasket Portion:*

10.10.4.16 An indication of compliance with 10.10.3.1 and the 13 inspection location points in accordance with 10.10.3.3,

10.10.4.17 If the shelter was equipped with RFI gaskets,

10.10.4.18 If an inadequate gasket bearing was found and at what location,

10.10.4.19 Date inspection was performed,

10.10.4.20 A statement that rework was performed, if applicable, and

10.10.4.21 Date reinspection was performed, if applicable.

10.10.4.22 *Availability of Records*—The contractor shall make the above records available to the purchaser for review upon request.

10.11 *Finish*—Inspect finish in accordance with the quality assurance provisions of MIL-F-14072, including paint adhesion, and 10.14 of this specification (see 5.8, Table 3, and Table 6).

10.12 *Marking*—Visually inspect marking to determine compliance with 5.9 (see 10.14 and Table 3).

10.13 *Dimensional*—To determine compliance with the drawings (see 5.1), measure the shelter and check in the following areas (see Table 3 and Table 5):

10.13.1 Overall dimensions, squareness, parallelism, flushness of the corner miter joints, and flatness of the gasket contact surface of the door opening in accordance with SM-D-947160 and Note 38 in accordance with SM-D-947080. Inspect flatness by measuring the flatness of the four sides and the flatness at the corners along the diagonals using a straight edge with a center rest point.

10.13.2 Overall interior dimensions in accordance with SM-D-947080.

10.13.3 *Flatness*—106 measurements in accordance with SM-D-947181: four deviations are acceptable, five deviations are cause for rejection of the shelter.

10.13.4 *Squareness*—64 measurements in accordance with SM-D-947181: seven deviations are acceptable, eight deviations are cause for rejection of the shelter.

10.13.5 Visibility of center marks for mounting members.

10.14 *Visual and Mechanical*—Visually inspect the shelter for Type 4, 5, 7, 8, 9, and 11 defects in accordance with MIL-STD-252 and to determine compliance with the requirements of 5.8, 5.9, 5.9.1, and 9.3 (see 10.11, 10.12, Table 3, and Table 5).

10.15 *Shelter Weight*—Weigh the shelter on a scale with an accuracy of ±1 lb (± 0.5 kg) or ⅒ of 1 %, whichever is smaller. Calibrate the scale, at least once every two weeks, using standard weights traceable to the National Institute of Standards and Technology. Meet the requirements of 5.10 (see Table 3 and Table 5).

10.16 *Door Latch Torque*—Make torque measurements using a torque wrench fitted with an adapter that seats over the outside door handle and in line with the shaft centerline. Then

open and close the door using the torque wrench. Make measurements over the entire working range of the latch in both cases. Record both maximum readings and meet the requirements of 8.3 (see Table 3, Table 4, and Table 5).

10.17 *Moisture Resistance Test*—Subject the shelter with the door closed and the emergency exit fully open to the moisture resistance test of MIL-STD-810E, Method 507.3, Procedure II. After cycling has been completed, there shall be no evidence of delamination, cracking, corrosion, or deterioration to any part of the shelter and there shall be no malfunction of doors, latches, hinges, or any other hardware. Failure to meet the requirements of 5.11 and 6.2 shall constitute failure of this test.

10.18 *Temperature*—Subject the shelter, with door and cover closed, to the following tests (see 6.3 and Table 3):

10.18.1 Place the shelter, in the upright position, in a chamber in accordance with 10.20. The velocity of the ambient air outside the shelter shall not exceed 15 miles per hour (24 km/h) near the shelter surfaces. Stabilize the ambient temperature inside and outside the shelter at 120 to 125°F (49 to 52°C) as measured by eight thermocouples. Measure the inside shelter temperature by four thermocouples: two in each of two diagonally opposite corners, 6 in. (150 mm) from the shelter walls, and at levels 12 (300 mm) and 60 in. (1.5 m) above the shelter floor. Measure the outside temperature by four thermocouples: one at each side and end panel, approximately midway along the panel, with each thermocouple located 44 in. (1.1 m) above the bottom of the skids and between 9 and 24 in.

(230 and 610 mm) from the panel. No thermocouple shall be within 9 in. (230 mm) of a chamber wall. After ambient stabilization is achieved, apply a solar load to the shelter roof as rapidly as possible. Apply the solar load using at least 28 lamps, Type 1000 T3, 230 V.<sup>9</sup> Arrange the lamps in four rows of seven each (or more) and operate with 10 % of rated voltage. There shall be no obstruction between the lamps and the shelter panel. Measure the temperature of the roof outer skin by 15 thermocouples arranged as shown in Fig. 3 and mounted in contact with the painted skin surface. Apply the solar load to produce a temperature of 200 to 230°F (93 to 110°C) as measured by the 15 thermocouples. The following are permissible and may be required in order to meet this temperature requirement: vertical movement of lamp(s), geometric projection of lamp(s) is beyond the shelter panel, variation of voltage to lamp(s) within 10 %. Maintain the solar load for 4 h, during which time maintain the ambient temperature outside the shelter between 120 and 130°F (49 to 54°C). After the 4 h period, remove the solar load and increase the ambient temperature, both inside and outside the shelter, to between 160 and 166°F (71 to 74°C), as indicated by all 23 thermocouples described. Use an electrical resistance heat source inside the shelter to assist in achieving this temperature distribution. Do not use the solar lamps to achieve or assist in achieving this rise in temperature. Then open the shelter door and reduce the

<sup>9</sup> Commercially available from several sources.

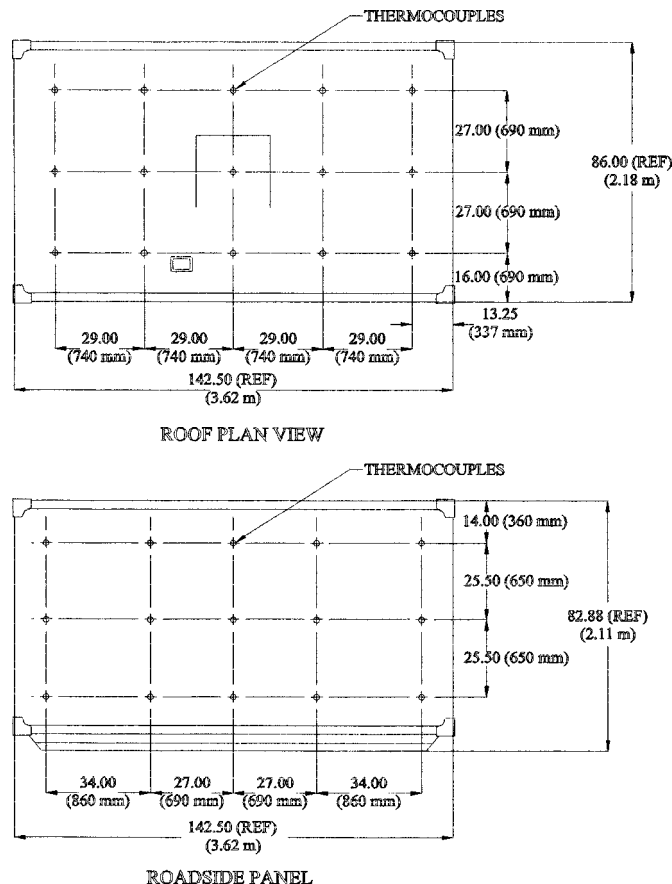

FIG. 3 Thermocouple Locations for Solar Load Tests

ambient temperatures as rapidly as possible to 65 to 95°F (18 to 35°C). After this test the requirements of 5.11 shall be met.

10.18.2 *Storage Test*—Subject the shelter alternately to Method 501.3 Section II-3.1 and Method 502.3 Section II-3.1 of MIL-STD-810E, except perform three cycles of each test (high temperature and low temperature). The cycles shall range from 160°F (71°C) for the high temperature tests and -80°F (-62°C) for low temperature tests (as measured by the thermocouples). In addition, all doors and latches shall operate freely without binding at either temperature extreme.

10.19 *Thermal Differential*—(See 6.4 and Table 2). Place the shelter in a chamber in accordance with 10.20 and that maintains a constant temperature environment of -40°F (-40°C) outside the shelter. Place an electrical resistance heat source inside the shelter. The heat source shall have sufficient power to maintain a stabilized temperature inside the shelter of not less than 100°F (38°C) above the outside temperature. Air circulation shall be sufficient to provide temperature uniformities inside and outside the shelter within 5°F (3°C) as measured by twelve thermocouples placed 6 in. (150 mm) from the shelter walls at two diagonally opposite corners. Place six thermocouples, three in each corner, inside, two at 6 in. (150 mm), two at 38 in. (970 mm), and two at 67 in. (1.7 m) above the shelter floor. Place six thermocouples, three in each corner, outside, two at 12 in. (300 mm), two at 49 in. (1.2 m), and two at 94 in. (2.4 m) above the bottom of the skids. Consider the temperature conditions stable when, for 30 min the six inside and the six outside thermocouple readings remain within 5°F (3°C) each and the average inside temperature remains not less than 100°F (38°C) above the average outside temperature. To minimize any pressure differential between the inside and outside of the shelter, incorporate a form of pressure relief into the drain hole. Avoid rapid changes in temperature during and after the test.

10.19.1 *Thermal Deformation*—After exposure to the environmental conditions of 10.19, the shelter shall meet the requirements of 5.11 and 6.4.1.

10.19.2 *Heat Transfer*—Under the conditions of 10.19, consider the electrical power input stabilized. Consider all electrical power supplied to apparatus within the shelter (heaters, fans, lights, etc.) during this test in the calculation of the overall coefficient of heat transfer. Do not use voltmeters and ammeters in place of a wattmeter for computing power inputs. Record four sets of temperature and power readings during the 30 min period. Do not change the power. Power readings may vary as much as 5 % to allow for normal fluctuations during this period. Operate all electrical apparatus inside the shelter continuously during this period and not cycled off and on. Calculate the overall coefficient of heat transfer using the electrical power input, the average inside and outside temperatures, and the nominal inside surface area. Meet the requirements of 6.4.2.

10.20 *Test Chamber*—The test chamber used for environmental testing of the shelter shall be in accordance with the following (see 10.17-10.19):

10.20.1 The volume of the test chamber shall be such that the bulk of the shelter will not interfere with the generation and maintenance or the test conditions. The minimum distance

from any shelter panel to the adjacent wall of the chamber shall be 24 in. (610 mm).

10.20.2 Suitably baffle the conditioned airflow to provide free circulation between the shelter and the chamber walls and ceiling and to provide uniform airflow around the shelter. Air velocity near the shelter surfaces shall be in accordance with the specific test paragraph.

10.20.3 Locate the heat or cold source of the chamber so that the heat or cold from the source will not fall directly on the shelter, except where application of radiant heat is one of the test conditions.

10.20.4 Baffle or otherwise protect thermocouples against radiation effects.

10.20.5 For moisture resistance testing: construct the chamber and accessories and arrange in such a manner as to avoid condensate dripping on the shelter. Trap-vent the chamber to the atmosphere to prevent the buildup of total pressure. Determine relative humidity from the dry bulb-wet bulb thermometer comparison method or an equivalent method approved by the purchaser. When readout charts are used, they shall be capable of being read with a resolution with 1°F (0.6°C). When the wet bulb control method is used, clean the wet bulb and tank and a new wick installed before starting the test. The air velocity flowing across the wet bulb shall be not less than 900 ft/min (275 m/min). Make provisions for controlling the flow of air throughout the internal chamber test space where the velocity of air shall not exceed 150 ft/min (46 m/min). Use steam or distilled, demineralized, or deionized water having a pH value between 6.0 and 7.2 at 73°F (23°C) to obtain the specified humidity. Impose no rust or corrosive contaminants on the shelter by the test facility.

10.21 *Rail Transport, Impact Test*—Load the shelter with a 5000 lb (2270 kg) load in accordance with DL-SM-B-947186 per section 7.1 and load on a railroad flat car, with standard (draft gear) couplings, in accordance with Fig. 4. Perform the test in accordance with MIL-STD-810E, Method 516.4, Procedure VIII. Rail Transportability Tests shall be performed for impacts at 4, 6, and 8 mph (6, 10, and 13 km/hr) and 8 mph (13 km/hr) reversed. Make a damage survey after each impact. The shelter shall have sustained no deformation and shall meet the requirements of 7.2.1 and 5.11. Failure to meet the requirements of 7.2.1 and 5.13 shall constitute a failure of this test.

10.21.1 *Test Flatcar*—The wooden planking of the test flatcar bed shall be in good condition. Secure all 6 by 6 in. (150 by 150 mm) and 8 by 8 in. (200 by 200 mm) blocking to the bed of the flatcar using 10 in. (250 mm) spikes on 12 in. (300 mm) centers minimum. Contact the 8 by 8 in. (200 by 200 mm) blocking along the door end and front end of the shelter against the towing eye caps and against the full width of the shelter between the caps as necessary to clear the towing shackles and rivet heads. Accomplish this by means of sawed notches. Install oak wedges between the towing eyes and the lumber to ensure rigid support at these points. Contact the blocking along the other sides of the shelter against the towing eye caps and along the full length of the shelter between the caps. Nail the 4 by 4 in. (100 by 100 mm) and 2 by 4 in. (50 by 100 mm) blocking to the bed of the flatcar as shown in Fig. 4. Firmly nail all other blocking as shown in the figure. The four tiedowns

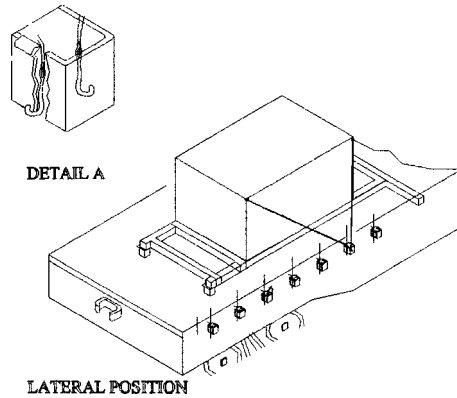

FIG. 4 Shelter Secured on Flatcar

shall each consist of  $\frac{3}{8}$  in. (10 mm) diameter 6 by 19, flexible steel, preformed wire rope (having a breakdown strength of 10 600 lb (4800 kg) minimum), a turnbuckle, two hooks, and thimbles and fasteners, as required. The breaking strength of each tiedown shall be 9000 lb (4100 kg) minimum. Before each impact, each tiedown shall be taut (600 to 800 lb (270 to 360 kg) tension).

10.22 *Drops*—Subject the shelter, with payload (see 7.1), to one flat drop and four rotational drops as described. All drops shall be in an environment with a temperature between 50 and 95°F (10 and 35°C). Perform the drops in the following order: flat drop, impact at rear (door) end, impact at front end, impact at roadside, and impact at curbside (see 7.3, 12.3.3.1, Table 3, and Table 4).

10.22.1 *Flat Drop*—Lift the shelter  $18 \pm \frac{1}{4}$  in. ( $460 \pm 6$  mm) from the ground. Take measurements from the bottom of the skids at the four corners of the shelter. The range of the four measurements shall not exceed  $\frac{1}{4}$  in. (6 mm). Release the shelter and allow to fall freely such that the skids impact onto a hard concrete surface. Meet the requirements of 5.11 and 7.3.

10.22.2 *Rotational Drops*—Place a 4 in. (100 mm) high (nominal) board under the skid(s) at one edge of the shelter. Lift the opposite edge of the shelter  $18 \pm \frac{1}{4}$  in. ( $460 \pm 6$  mm) from the ground. Take measurements from the center of the bottom of the skid(s) at the two raised corners of the shelter. The range of the two measurements shall not exceed  $\frac{1}{4}$  in. (6 mm). Release the shelter and allow to fall freely such that the skid(s) impacts onto a hard concrete surface. After all four rotational drops the requirements of 5.11 and 7.3 shall be met.

10.23 *Towing Simulated*—Place the shelter so that the outboard vertical face of the roadside skid is flush against a  $1 \frac{1}{4} \pm \frac{1}{8}$  in. ( $32 \pm 3$  mm) high face that is rigidly secured to the ground and that runs the full length of the skid. Apply a 3000 lb force (1360 kg) to each roadside towing eye. Each force shall be in a direction parallel to the ground and perpendicular to the side of the shelter. Restrain the shelter from sliding or rotating. Repeat the test on the curbside skid and towing eyes. In both cases, meet the requirements of 5.11 and 7.4 (see Table 3 and Table 4).

10.24 *Lifting and Towing Eyes*—Perform all lifting and towing eye tests in an environment with a temperature between 50 and 95°F (10 and 35°C) (see 7.5).

10.24.1 *Eye Pulls*—Subject each lifting and towing eye on the shelter to a tensile load applied in each of three mutually

perpendicular directions that are described by the line of intersection of two adjacent panels. Perform the test by outward pulls between each adjacent pair of eyes. All pulls shall be to 14 400 lb (6500 kg). After all pulls the requirements of 5.11 and 7.5.1 shall be met (see Table 3 and Table 6).

10.24.2 *Eye Casting Hardness*—Prepare the lifting and towing eye casting for test by obtaining the proper surface finish in a localized area near the center of the 2.50 in. (64 mm) as required for performing the Brinell Hardness Test. Test the casting hardness utilizing a 10 mm ball and a 500 kg load. The requirements of 7.5.2 shall be met (see 12.2.10, Table 1, and Table 2).

10.25 *Air Transport, Simulated*—Load the shelter with 17 500 lb (7950 kg) of water in a waterproof bag. Rest the bag against the floor and sides of the shelter and against boards placed across the door opening. Then suspend the shelter by the four lifting eyes using the hold down assembly of 9.2 for a period of 30 min. Examine the shelter within 1 h after removal of the load. The requirements of 5.11 and 7.2.2 shall be met (see Table 3 and Table 4).

10.26 *Static Door Load*—Open the shelter door to 90°. Apply a vertical load of 200 lb (90 kg) to the door at 36 in. (510 mm) from the hinge pivot line for 30 min. The requirements of 5.11 and 7.6 shall be met (see Table 3 and Table 6).

10.27 *Roof Access*—Randomly select one of the roof access steps on the shelter. Apply a vertical load of 400 lb (180 kg) at the center of the opened outer section for a period of 30 s. The requirements of 5.11 and 7.7 shall be met (see Table 3 and Table 6).

10.28 *Light Tightness*—Test the intake louver assembly, as installed in the shelter, with the emergency exit cover fully open, but with the air filter, SM-C-450466 removed, for light tightness as follows: place a bare, lighted 100 W incandescent lamp in a plate 1 ft (300 mm) from the outside louver surface. Regardless of the position of the lamp in the plane relative to the louver and the position of an observer in the darkened shelter interior, the requirement of 8.4 shall be met (see Table 3 and Table 6).

10.29 *Electromagnetic Interference (EMI) Suppression*—Test the shelter for shielding in accordance with methods of Test Method E 1851 and Specification E 1925 and the requirements of 8.5. Install the EMI shields and EMI filter in accordance with drawings as listed in 17-1-3274 for the test. No other modification will be made. Perform tests at the

following frequencies with air louver cover secured in the full open position. Failure to meet the requirements of 8.5 shall constitute failure of this test: (see 12.3.3.2, Table 3, and Table 4):

- 10.29.1 150 kHz and 18.0 MHz for magnetic field,
- 10.29.2 400 MHz, 1.0 GHz, and 10.0 GHz for plane waves.

10.30 *Watertightness*—Subject the shelter, without the use of any external sealing, caulking, taping, etc., except as called for on the drawing, to the following two-part test (see 5.5, 8.6, Table 2, and Table 6).

10.30.1 Spray each of the five exposed surfaces of the shelter, with door and covers closed, with water from nozzles.<sup>10</sup> Test each end panel using nine nozzles, each side panel using 15 nozzles and the roof panel using six nozzles; nozzle locations in accordance with Fig. 5. Operate each nozzle at a pressure of 40 psig (280 KPa) at the nozzle. Spray each panel continuously for a period of 40 min, (if the watertightness test is followed by the fording test of 10.31, the bottom row of nozzles can be eliminated with the exception of the nozzles facing the door end panel). Prior to the performance of the spraying, fully open and close the door of the shelter so that the latching mechanism is completely engaged for a total of ten operations.

10.30.2 Test the inlet louver with the door closed and the louver cover fully open, by spraying water at the door end panel. Use five nozzles, as used above, located in accordance with Fig. 6. Operate each nozzle at a pressure of 15 psig (100 KPa) at the nozzle. Spray the panel continuously for a period of 20 min. After both parts of this test, there shall be no evidence of leakage into the shelter or into the walls, floor, roof, or door. To determine that no water has entered space between the skids, make holes (not less than four, not more

than ten) at points to be determined by the purchaser at the time of testing, and tilt the shelter to allow the water to run towards the hole. There shall be no evidence of water. After this determination, seal the holes with rivets and sealer.

10.31 *Fording*—Immerse the shelter, as prepared for transportation on a military cargo truck, in water to a depth of 21 in. (530 mm) measured from the bottom of the shelter skids. Use no special fording kits in the performance of this test. Use no external caulking, taping, etc., except as called for on the drawings. Immerse the shelter and remain submerged for 1 h, and restrained by external tiedown. There shall be no evidence of leakage into the shelter, or into the walls, floor, or door. To determine that no water has entered space between the skin, make holes (not less than four, not more than ten) at points determined by the purchaser at the time of testing, and tilt the shelter to allow the water to run towards the holes. There shall be no evidence of water. After this determination, seal the holes with rivets and sealer (see 5.5, 8.7, 10.30, Table 3, and Table 4).

10.32 *Hold Down Assembly*—Subject each of the four cable assemblies of the hold down assembly to a destructive tensile load. Fail the cable before slippage occurs at the sleeves. Fail each sling leg at a load higher than 14000 lb (6350 kg). Failure to meet the requirements of 9.2 (see 12.3.3.3, Table 1, and Table 4) shall constitute failure of this test.

**11. First Article Inspection**

11.1 *First Article Inspection*—Unless otherwise specified (see 15.1.2, and 15.2), all first article test and inspections shall be performed by the contractor and shall consist of the following (see 9.1):

11.1.1 *First Article Specimens*—The contractor shall provide and test the first article specimens listed in Table 1. All specimens shall reflect materials and conditions that will be used in production (see 15.2 and Table 2).

11.1.2 *First Article Shelter*—The contractor shall provide and test a first article shelter which shall reflect material and conditions that will be used in production. Inspection shall consist of the inspections listed in Table 2. Inspection shall be

<sup>10</sup> The sole source of supply of the apparatus, Model G2950 (or GC2950), known to the committee at this time is Spraying Systems Company, Bellwood, IL. If you are aware of alternative suppliers, please provide this information to ASTM Headquarters. Your comments will receive careful consideration at a meeting of the responsible technical committee, that you may attend.

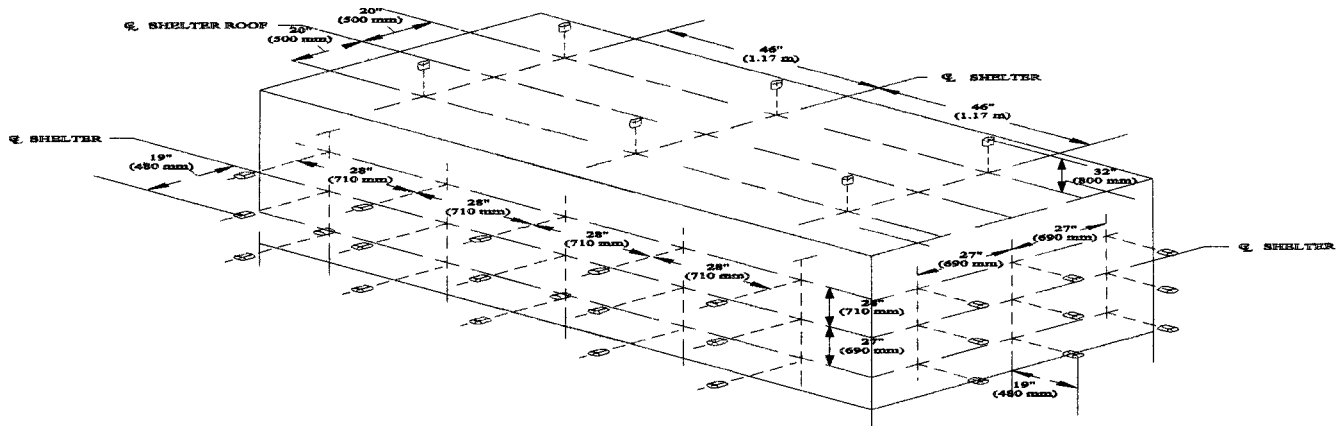

- NOTE 1—Tolerance = 1/2 in (13 mm).
- NOTE 2—Nozzle locations for the rear and roadside panels are the same as for the front end and curbside panels, respectively, shown above.
- NOTE 3—Nozzle axis perpendicular to shelter surface in all cases.
- NOTE 4—Gages shall be permanently installed to indicate pressure at remote nozzles.

**FIG. 5 Nozzle Locations for Watertightness Test**

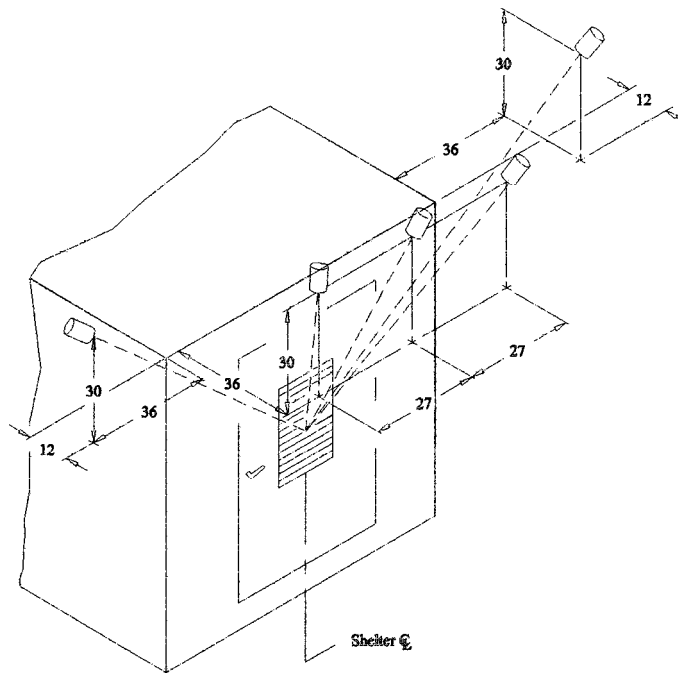

NOTE 1—Gages shall be permanently installed to indicate pressure at remote nozzles.

NOTE 2—Air inlet cover shall be fully open.

FIG. 6 Nozzle Locations for Watertightness Test

in the sequence listed in Table 2.

## 12. Quality Conformance Inspection

12.1 *Quality Conformance Inspection*—The contractor shall perform the inspections specified under this subsection. This does not relieve the contractor of his responsibility for performing any additional inspection which is necessary to control the quality of the product and to assure compliance with all specification and drawing requirements.

12.2 *In-Process*—The inspections specified in Table 3 shall be performed during the shelter manufacturing process and at the frequency specified below.

12.2.1 *Sampling for Core Material Properties*—Inspection of specimens for core material density, compressive strength, and shear strength properties shall be made once from the core material used in the first 50 shelters and once from the core material used in each additional 50 shelters or fraction thereof (see 4.2, 13.1, and Table 2).

12.2.2 *Sampling for Adhesive and Sealer, Low and High Temperature*—Inspection of adhesive and sealer coupons at the low and high temperature conditions shall be at the following frequencies (see 4.3, 4.4.1, 4.4.3, 10.2, and Table 2).

12.2.2.1 When automatic mixing and dispensing processes are used: once each calendar week.

12.2.2.2 When hand mixing and dispensing processes are used: once for each 15 batches.

12.2.3 *Sampling for Adhesive and Sealer, Room Temperature*—Inspection of adhesive and sealer coupons at the room temperature condition shall be at the following frequencies (see 4.3, 4.4.2, 10.2, and Table 2):

12.2.3.1 When automatic mixing and dispensing processes are used: once at the start of the process, once at the end of a

shift, and once at the end of a continuous run longer than one shift.

12.2.3.2 When hand mixing and dispensing processes are used: once at the start of the process, once each whenever there is a change in batch, operating personnel and shift.

12.2.4 *Sampling for Shock Mounts*—Three shock mounts shall be randomly selected from the first 300 mounts produced, three from the next 900 mounts produced and three from each additional 1200 mounts or fraction thereof produced (see 4.5, 10.3.2, and Table 2).

12.2.5 *Sampling for Cleaning*—Frequency of process inspections for cleaning shall be in accordance with SM-B-947180 (see 5.2, 10.4, and Table 3).

12.2.6 *Sampling for Welding*—Frequency of visual inspection of arc welding shall be in accordance with the requirements of maintenance sampling for production of MIL-W-8604. For resistance welding, frequency of fabrication and inspection of production specimens and frequency of inspection of production parts shall be in accordance with MIL-W-6858 (see 5.3, 10.5, and Table 2).

12.2.7 *Sampling for Lamination*—All roof, floor, wall, and door panels shall be inspected for delaminations and unbond type voids prior to their assembly into a shelter (see 5.4, 10.6, and Table 2).

12.2.8 *Sampling for Interchangeability*—Each shelter shall comply with the inspection of 10.8 and meet the requirement of 5.6.

12.2.9 *Sampling for Riveting*—One shelter shall be randomly selected from each ten shelters produced. Selection and inspection shall be prior to application of paint finish (see 5.7, 10.9, and Table 2).

12.2.10 *Sampling for Eye Casting Hardness*—Lifting and

towing eye castings shall be inspected utilizing special inspection level S-4, AQL 6.5 % in accordance with MIL-STD-105 (see 7.5.2, 10.24.2, and Table 2).

12.2.11 *Sampling for Construction Tightness, Shelter Portion*—All shelters shall be preconditioned in accordance with 10.10.1 (see 5.12).

12.3 *Completed Items*—Completed items (see 14.3) shall be inspected in accordance with the following subsections. When AQL percents are specified, inspection shall be performed utilizing the multilevel continuous sampling procedure, CSP-T, of MIL-STD-1235. The sampling frequency code letter used shall be “A”. The production interval shall be the entire contract quantity of shelters.

12.3.1 *Group A Inspection*—Except for the shelter portion of the construction tightness test, that shall be performed on Group A Audit units only, the inspection specified in Table 5 shall be performed on each shelter. Conforming shelters shall then be verified by a Group A audit utilizing the AQL percents specified (see 10.10.4).

12.3.2 *Group B Inspection*—The inspections specified in Table 6 shall be performed on shelters that have been subjected to and satisfied Group A inspection. Inspection shall be in the order listed and in accordance with the footnote to Table 6. The provision in MIL-STD-1235 that requires that sampling inspection be terminated and 100 % inspection be resumed if the production process is interrupted for more than three operating days shall not apply.

12.3.3 *Group C Inspection*—Group C inspection shall consist of the inspections specified in Table 4. Shelter tests shall be performed on shelters that have been subjected to and satisfied Group A and Group B inspection. Unless otherwise specified, tests shall be in the order listed (see 3.1.1).

12.3.3.1 *Sampling for Drop*—One shelter shall be randomly selected from first 50 shelters produced. In the event that the first delivery quantity is less than 50 units, the sample shall be selected from the first delivery quantity but shall be considered the sample for the first 50 units. Thereafter one sample shall be selected from each additional 150 shelters or fraction thereof (see 7.3, 10.22, and Table 4).

12.3.3.2 *Sampling for Electromagnetic Interference Suppression*—One shelter shall be randomly selected from the first ten shelters produced, one shelter from the next 40 shelters produced, and one shelter from each additional 50 shelters or fraction thereof (see 8.5, 10.29, and Table 4).

12.3.3.3 *Sampling for Hold Down Assembly*—Two complete hold down assemblies in accordance with Drawing SC-D-36423 shall be randomly selected from the first 50 assemblies produced. In the event that the first delivery quantity is less than 50 units, the sample shall be selected from the first delivery quantity but shall be considered the sample for the first 50 units. Thereafter, one assembly shall be selected from each additional 100 assemblies or fraction thereof (see 9.2, 10.32, and Table 4).

12.3.3.4 *Sampling for Remainder of Group C Inspection*—These inspections shall be performed once during production on a shelter/specimen randomly selected from the first 50 shelters produced. In the event that the first delivery is less than 50 units, the sample shall be selected from the first delivery

quantity but shall be considered the sample for the first 50 units (see Table 4).

### 13. Packaging

13.1 *Quality Conformance of Packaging*—Packaging shall be inspected in accordance with MIL-S-55507. The requirements of 13.2 shall be met.

13.2 *Packaging Requirements*—The packaging requirements shall be in accordance with MIL-S-55507 (see 13.1).

### 14. Quality Assurance

14.1 *Responsibility for Inspection*—Unless otherwise specified in the contract, the contractor is responsible for the performance of all inspection requirements as specified herein. Except as otherwise specified in the contract, the contractor may use his own or any other facilities suitable for the performance of the inspection requirements specified herein, unless disapproved by the purchaser. The purchaser reserves the right to perform any of the inspections set forth in the specification where such inspections are deemed necessary to assure supplies and services conform to prescribed requirements.

14.2 *Classification of Inspections*—The inspection requirements specified herein are classified as follows:

14.2.1 First article inspection (see Section 11),

14.2.2 Quality conformance inspection (see Section 12),

14.2.2.1 In-process (see 12.2),

14.2.2.2 Completed items (see 12.3), and

14.2.3 Methods of examination and test (see Section 10).

14.2.4 Quality conformance inspection of packaging (see 14.1).

14.3 *Inspection Conditions*—Unless otherwise specified, all shelters submitted for quality conformance inspection shall be completely assembled. The final finish need not be applied until after the Group A, Group B, and Group C inspections have been performed on that shelter. If the final finish is applied prior to performance of the Group A, Group B, and Group C inspection, the final finish on the floor shall not be applied until prior to final inspection. If the final finish is not applied until after the Group A, Group B, and Group C inspections, then those inspections related to the finish and marking shall be performed at final inspection. Unless otherwise specified, no other adjustment, additions or modifications shall be made before or during test and inspection (see 12.3).

### 15. Notes

15.1 *Ordering Data*—Procurement documents should specify the following:

15.1.1 Title, number and date of this specification and any amendment thereto,

15.1.2 When a first article is required for inspection and approval (see 9.1, 15.2, and Section 11),

15.1.3 When electromagnetic interference suppression capability is required on all delivered shelters (see 5.1, 5.9.1, and 15.3),

15.1.4 If facsimiles are required (see 5.9.1),

15.1.5 If the overall coefficient of heat transfer is required (see 6.4.2),

15.1.6 Marking and shipping of sample shelters,



15.1.7 Place of final inspection of production shelters, and

15.1.8 Actions required relative to Group C failures and reinspection of conforming Group C samples units (see 3.1).

15.2 *First Article*—First article inspection shall be in accordance with Section 11 and shall consist of specimens (see 11.1) and one complete shelter with MK-1079/G installed. The purchaser should include specific instructions in all procurement instruments regarding arrangements for examinations, test, and approval of the first article, including test plan and test report requirements, if any (see 15.1.2).

15.3 *Noncompliance*—In the event of a Group C failure, approval to ship may be withheld, at the discretion of the purchaser, pending his decision on the adequacy of corrective action (see 12.3.3 and 15.1.8).

15.4 *Nomenclature*—The parentheses in the nomenclature will be deleted or replaced by a letter identifying the particular

design; for example: S-280X/G (see 1.1). The contractor should apply for nomenclature in accordance with the applicable clause in the contract.

15.5 *Verification Inspection*—Verification by the purchaser will be limited to the amount deemed necessary to determine compliance with the contract and will be limited in severity to the definitive quality assurance provisions established in this specification and the contract. The amount of verification inspection by the purchaser will be adjusted to make maximum utilization of the contractor's quality control system and the quality history of the product.

## 16. Keywords

16.1 adhesive bonded; aluminum; bonding; foam sandwich panels; non-expandable; relocatable structures; rigid wall

*The American Society for Testing and Materials takes no position respecting the validity of any patent rights asserted in connection with any item mentioned in this standard. Users of this standard are expressly advised that determination of the validity of any such patent rights, and the risk of infringement of such rights, are entirely their own responsibility.*

*This standard is subject to revision at any time by the responsible technical committee and must be reviewed every five years and if not revised, either reapproved or withdrawn. Your comments are invited either for revision of this standard or for additional standards and should be addressed to ASTM Headquarters. Your comments will receive careful consideration at a meeting of the responsible technical committee, which you may attend. If you feel that your comments have not received a fair hearing you should make your views known to the ASTM Committee on Standards, 100 Barr Harbor Drive, West Conshohocken, PA 19428.*