



Standard Test Method for Distillation of Petroleum Products at Reduced Pressure¹

This standard is issued under the fixed designation D 1160; the number immediately following the designation indicates the year of original adoption or, in the case of revision, the year of last revision. A number in parentheses indicates the year of last reapproval. A superscript epsilon (ϵ) indicates an editorial change since the last revision or reapproval.

This standard has been approved for use by agencies of the Department of Defense.

1. Scope *

1.1 This test method covers the determination, at reduced pressures, of the range of boiling points for petroleum products that can be partially or completely vaporized at a maximum liquid temperature of 400°C. Both a manual method and an automatic method are specified.

1.2 In cases of dispute, the referee test method is the manual test method at a mutually agreed upon pressure.

1.3 The values stated in SI units are to be regarded as the standard. The values in parentheses are for information only.

1.4 *This standard does not purport to address all of the safety concerns, if any, associated with its use. It is the responsibility of the user of this standard to establish appropriate safety and health practices and determine the applicability of regulatory limitations prior to use.* For specific hazard statements, see 6.1.4, 6.1.8.1, 10.11, and A3.2.1.

2. Referenced Documents

2.1 ASTM Standards:

D 613 Test Method for Cetane Number of Diesel Fuel Oil²

D 1193 Specification for Reagent Water³

D 1250 Guide for Petroleum Measurement Tables²

D 1298 Practice for Density, Relative Density (Specific Gravity), or API Gravity of Crude Petroleum and Liquid Petroleum Products by Hydrometer Method²

D 4052 Test Method for Density and Relative Density of Liquids by Digital Density Meter⁴

D 4057 Practice for Manual Sampling of Petroleum and Petroleum Products⁴

D 4177 Practice for Automatic Sampling of Petroleum and Petroleum Products⁴

3. Terminology

3.1 Definitions of Terms Specific to This Standard:

¹ This test method is under the jurisdiction of ASTM Committee D02 on Petroleum Products and Lubricants and is the direct responsibility of Subcommittee D02.08 on Volatility.

Current edition approved April 10, 2002. Published July 2002. Originally published as D 1160–51T. Last previous edition D 1160–02.

² Annual Book of ASTM Standards, Vol 05.01.

³ Annual Book of ASTM Standards, Vol 11.01.

⁴ Annual Book of ASTM Standards, Vol 05.02.

3.1.1 *atmospheric equivalent temperature (AET)*—the temperature converted from the measured vapor temperature using Eq A7.1. The AET is the expected distillate temperature if the distillation was performed at atmospheric pressure and there was no thermal decomposition.

3.1.2 *end point (EP) or final boiling point (FBP)*—the maximum vapor temperature reached during the test.

3.1.3 *initial boiling point (IBP)*—the vapor temperature that is measured at the instant the first drop of condensate falls from the lower end of the condenser section drip tip.

3.1.3.1 *Discussion*—When a chain is attached to the drip tip the first drop will form and run down the chain. In automatic apparatus, the first drop detection device shall be located as near to the lower end of the drip tip as practical.

3.1.4 *spillover point*—the highest point of the lower internal junction of the distillation column and the condensing section of the vacuum-jacketed column assembly.

4. Summary of Test Method

4.1 The sample is distilled at an accurately controlled pressure between 0.13 and 6.7 kPa (1 and 50 mm Hg) under conditions that are designed to provide approximately one theoretical plate fractionation. Data are obtained from which the initial boiling point, the final boiling point, and a distillation curve relating volume percent distilled and atmospheric equivalent boiling point temperature can be prepared.

5. Significance and Use

5.1 This test method is used for the determination of the distillation characteristics of petroleum products and fractions that may decompose if distilled at atmospheric pressure. This boiling range, obtained at conditions designed to obtain approximately one theoretical plate fractionation, can be used in engineering calculations to design distillation equipment, to prepare appropriate blends for industrial purposes, to determine compliance with regulatory rules, to determine the suitability of the product as feed to a refining process, or for a host of other purposes.

5.2 The boiling range is directly related to viscosity, vapor pressure, heating value, average molecular weight, and many other chemical, physical, and mechanical properties. Any of

*A Summary of Changes section appears at the end of this standard.

these properties can be the determining factor in the suitability of the product in its intended application.

5.3 Petroleum product specifications often include distillation limits based on data by this test method.

5.4 Many engineering design correlations have been developed on data by this test method. These correlative methods are used extensively in current engineering practice.

6. Apparatus

6.1 The vacuum distillation apparatus, shown schematically in Fig. 1, consists in part of the components described below plus others that appear in Fig. 1 but are not specified, either as to design or performance. Some of these parts are not essential for obtaining satisfactory results from the tests but are desirable components of the assembly for the purpose of promoting the efficient use of the apparatus and ease of its operation. Both manual and automatic versions of the apparatus must conform to the following requirements. Additional requirements for the automatic apparatus can be found in Annex A9.

6.1.1 *Distillation Flask*, of 500-mL capacity, made of borosilicate glass or of quartz conforming to the dimensions given in Fig. 2 or Fig. 3, and having a heating mantle with insulating top. These dimensions can vary slightly by manufacturer, and are not considered critical dimensions, with the exception of the position of the end of the temperature sensing probe, and the inner diameter of the connection to the distillation column not being less than the inner diameter of the distillation column. The use of the thermowell can be replaced by an encased temperature probe and the second side neck is present on commercially available flasks used in this test method.

6.1.2 *Vacuum-Jacketed Column Assembly*, of borosilicate glass, consisting of a distilling head and an associated condenser section as illustrated in the lettered drawing, Fig. 4 and Table 1. The head shall be enclosed in a completely silvered glass vacuum jacket with a permanent vacuum of less than 10^{-5} Pa (10^{-7} mm Hg) (Note 1). The attached condenser section shall be enclosed in water jackets as illustrated and have an adapter at the top for connection to the vacuum source. A light drip-chain shall hang from the drip tip of the condenser to a point 5 mm below the 10-mL mark of the receiver as shown in Fig. 5. Alternatively, instead of the metal drip-chain, a metal trough may be used to channel the distillate to the wall of the receiver. This trough may either be attached to the condenser drip tip as shown in Fig. 5 or it may also be located in the neck of the receiver.

NOTE 1—There is no simple method to determine the vacuum in the jacket once it is completely sealed. A Tesla coil can be used, but the spark can actually create a pinhole in a weak spot in the jacket. Even the slightest pinhole or crack not readily detectable by sight alone will negate the vacuum in the jacket.

6.1.3 *Vapor Temperature Measuring Device* and associated signal conditioning and processing instruments (Annex A1) for the measurement of the vapor temperature. The system must produce readings with an accuracy of $\pm 0.5^{\circ}\text{C}$ over the range 0 to 400°C and have a response time of less than 200 s as described in Annex A2. The location of the vapor temperature sensor is extremely critical. As shown in Fig. 6, the vapor temperature measuring device shall be centered in the upper portion of the distillation column with the top of the sensing tip 3 ± 1 mm below the spillover point (see 3.1). The vapor

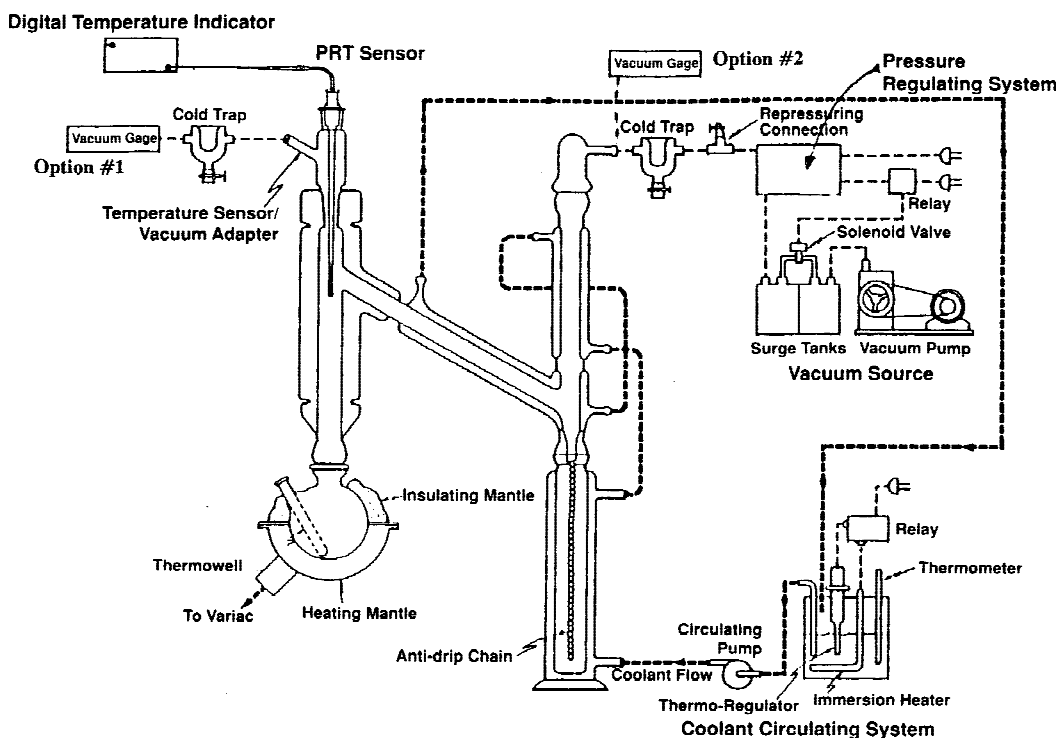

NOTE 1—A cold trap can be inserted before the pressure transducer in Option No. 2, if desired, or if the design of the transducer, such as a mercury McCleod gage, would require vapor protection.

FIG. 1 Assembly of Vacuum Distillation Apparatus

ASTM D 1160 - 02a

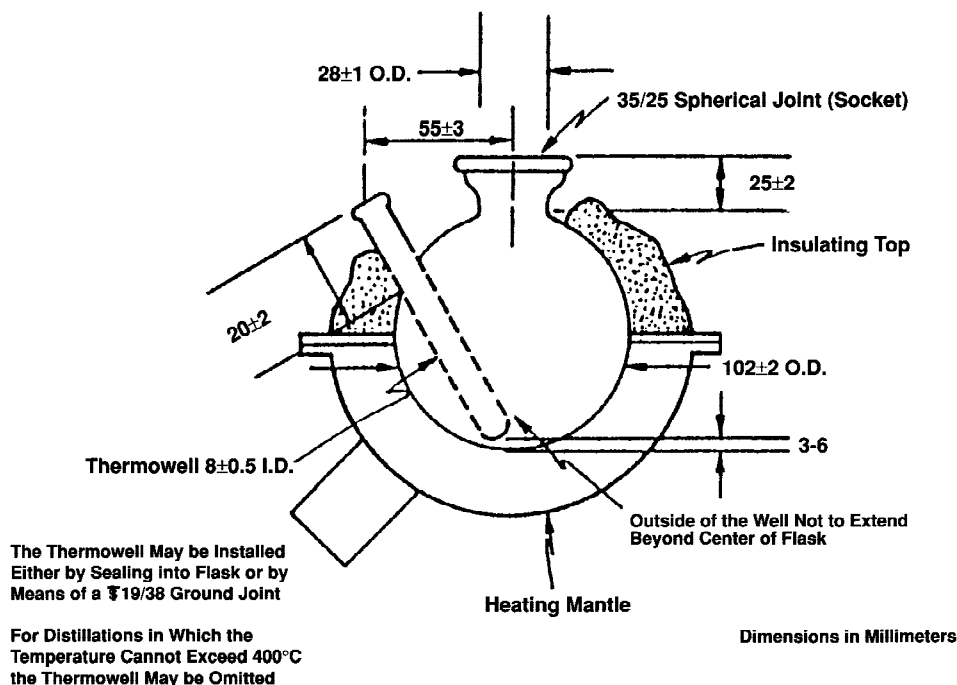

FIG. 2 Distillation Flask and Heating Mantle

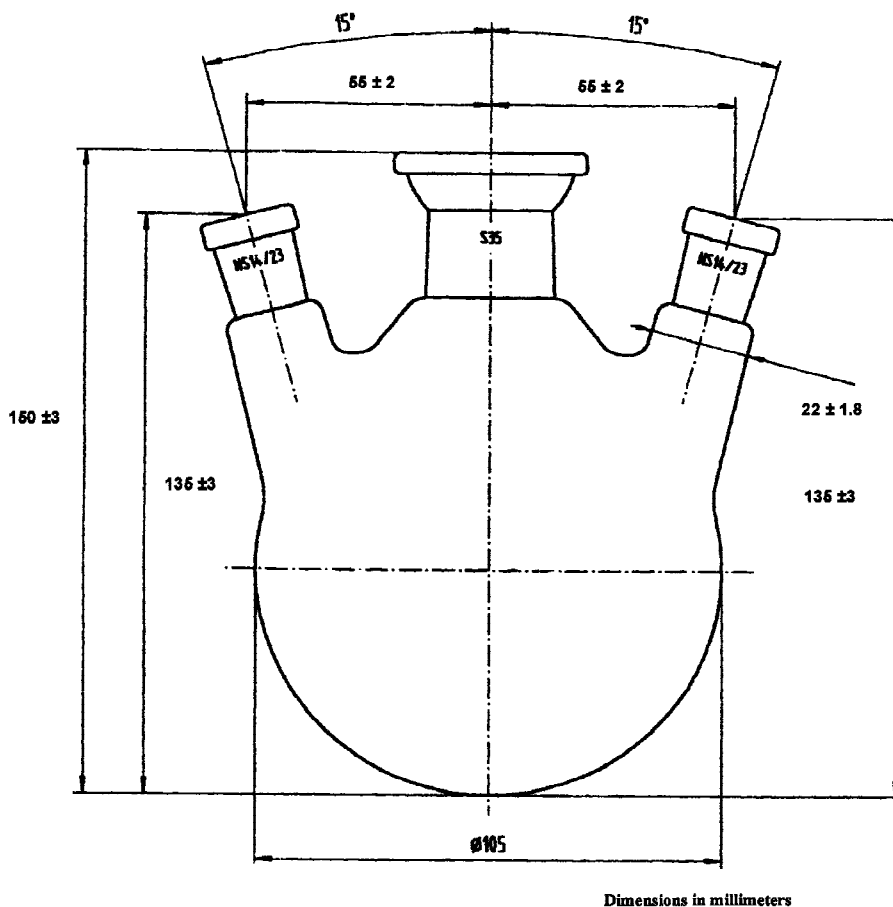

FIG. 3 Distillation Flask 500ML

temperature measuring device can consist of different configurations depending if it is a platinum resistance in glass or metal,

or if it is a thermocouple in glass or metal. Figs. 7 and 8 show the proper positioning of these two types in relation to the

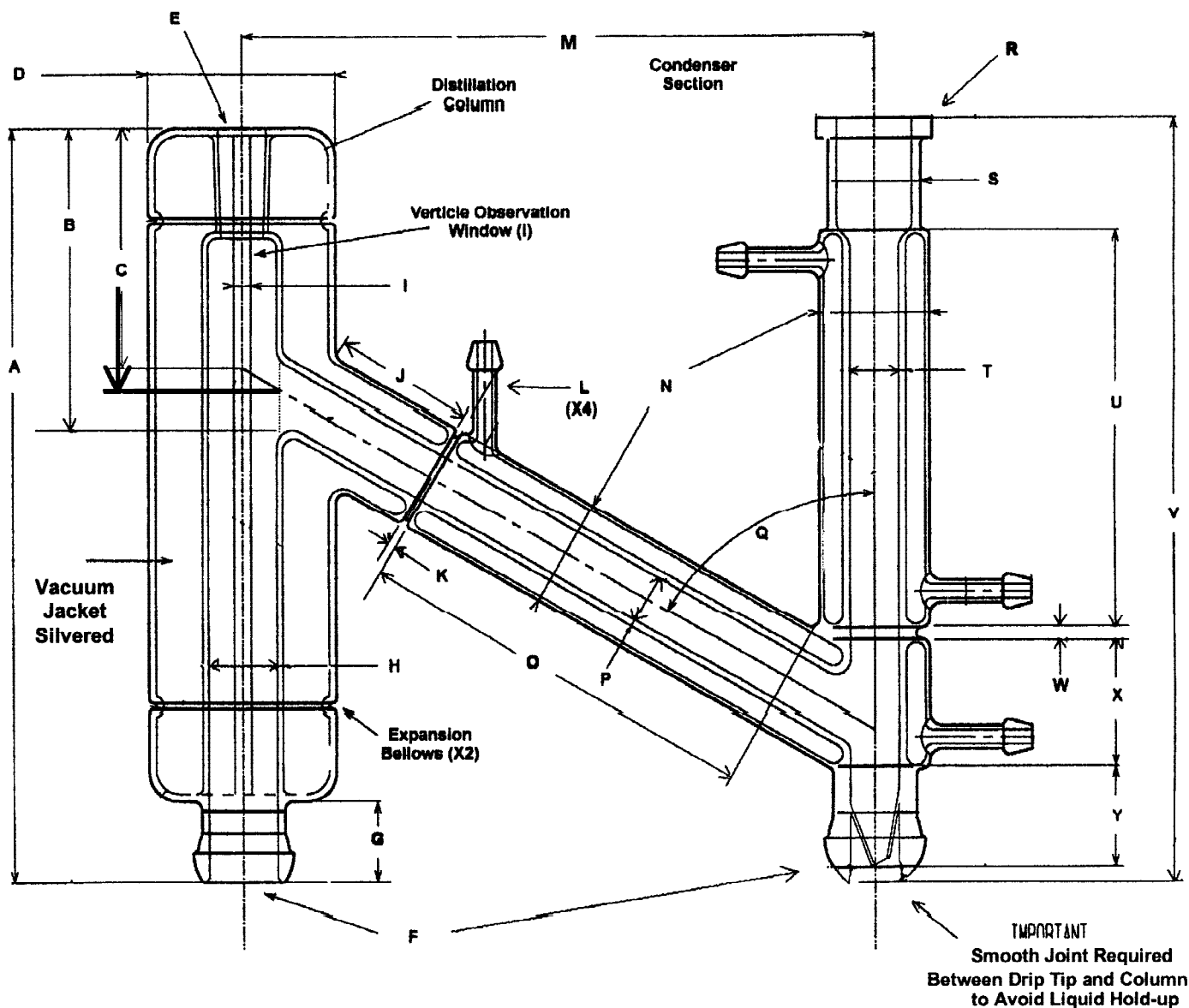

FIG. 4 Vacuum-Jacketed Column

spillover point. In glass platinum resistance devices the top of the spiral winding is the top of the sensing tip, in thermocouples it is the top of the thermocouple junction, in metal jacketed devices it is 1 ± 1 mm above the bottom of the device. An alignment procedure is described in Appendix X1. The vapor temperature measuring device shall be mounted through a compression ring type seal mounted on the top of the glass temperature sensor/vacuum adapter or fused into a ground taper joint matched to the distillation column. In some distillation apparatus configurations, the vacuum adapter at the top of the distillation column can be omitted. In these cases, the position of the vapor temperature measuring device shall be adjusted accordingly. The boiler temperature measuring device may be either a thermocouple or PRT and shall also be calibrated as above.

6.1.4 *Receiver* of borosilicate glass, conforming to the dimensions shown in Fig. 9. If the receiver is part of an automatic unit and is mounted in a thermostated chamber, the jacket is

not required. (**Warning**—The glass parts of the apparatus are subjected to severe thermal conditions and, to lessen the chances of failure during a test, only equipment shown to be strain-free under polarized light should be used.)

6.1.5 *Vacuum Gage*, capable of measuring absolute pressures with an accuracy of 0.01 kPa in the range below 1 kPa absolute and with an accuracy of 1 % above this pressure. The McLeod gage can achieve this accuracy when properly used, but a mercury manometer will permit this accuracy only down to a pressure of about 1 kPa and then only when read with a good cathetometer (an instrument based on a telescope mounted on a vernier scale to determine levels very accurately). An electronic gage such as the Baratron is satisfactory when calibrated from a McLeod gage but must be rechecked periodically as described in Annex A3. A suitable pressure calibration setup is illustrated in Fig. A3.1. Vacuum gages based on hot wires, radiation, or conductivity detectors are not recommended.

TABLE 1 Vacuum-Jacketed Column Assembly Dimensions

NOTE 1—These dimensions are for guidance for verifying the appropriate construction of the assembly. The actual dimensions used by glassmakers vary to some extent, and the dimensions they use to construct the assembly are not easily obtained after the assembly is fused together. Those dimensions noted as critical shall be adhered to within the tolerance listed. The dimensions listed in this chart have been gathered from users of the various manufactured manual and automatic apparatus who participated in the interlaboratory program to produce the precision for this test method.

NOTE 2—**Important**—Further study will progress to produce a set of dimensions which will be more restrictive in range of dimension, since it is believed that the current wide variance in dimensions has resulted in precision for this test method to be significantly high. The target dimensions for this assembly and other components of the apparatus are expected to be available within the next year, with implementation expected to occur after five years of initial revised test method publication date.

Component	Critical	Dimensions ^A	Notes
A	no	265 ± 10	...
B	yes	99 ± 4	Spillover point
C	yes	85 ± 3	Internal measurement difficult, used by manufacturer for assembly. Dimension is where center of angled inner tube intersects with the inner wall of the vertical column
D (OD)	no	64.5 ± 2	...
E	no	14/23 or 19/38	Tapered ground joint – female ^B
F	no	35/25	Spherical ground joint – male ^B
G	no	35 ± 10	This area to be covered by the insulating top of the heating mantle
H (ID)	yes	24.7 ± 1.2	Use of 28 mm OD tubing achieves this dimension
I	no	2 – 12	Window allows observation of boil-up rate and column cleanliness, but also allows detrimental heat loss
J	no	60 ± 20	...
K	no	12 ± 7	...
L (OD)	no	8	Minimum, cooling medium connections
M	yes	230 ± 13	This dimension determines condensed vapor run down time and affects temperature/recovery results
N (OD)	no	38 ± 2	...
O	yes	140 ± 20	This dimension affects vapor condensing efficiency which influences temperature/recovery results
P (ID)	yes	18.7 ± 1.1	Use of 22 mm OD tubing achieves this dimension
Q	yes	60 ± 2°	...
R	no	not applicable	Connection to vacuum system; any suitable means is allowed
S	no	not applicable	Extension above condensing section; must maintain minimum or greater internal diameter of condensing section
T (ID)	yes	18.7 ± 1.1	Use of 22 mm OD tubing achieves this dimension
U	yes	140 ± 5	This dimension affects vapor condensing efficiency which influences temperature/recovery results
V	no	not applicable	Extensions on the upper and lower portions of the condensing section vary by manufacturer and have no influence on the test
W	no	12 ± 7	...
X	yes	50 ± 8	...
Y	yes	30 ± 7	Distance to end of drip tip

^A All dimensions are in millimetres.

^B Ground glass joints from different sources may have one of a number of diameter to length ratios. For purposes of this test method, any are suitable, and in some instances, the diameter itself is not critical. However, it is critical that the male and female parts of each joint are from the same series to avoid recession or protuberance.

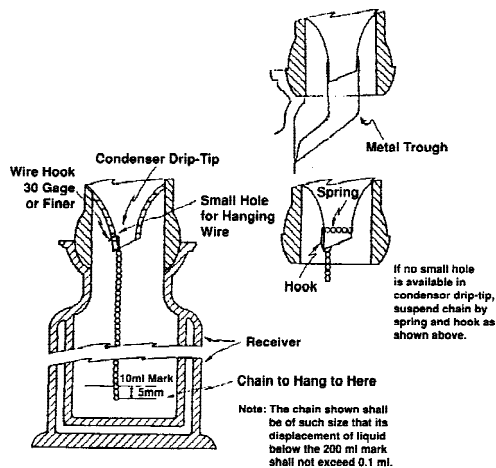

FIG. 5 Detail of Drip-Chain or Trough Attachment to Condenser

NOTE 2—Suitable instruments for measuring the pressure of the system during the test are the tensimeter or an electronic pressure gage, provided the output is traceable to a primary gage, such as the non-tilting McLeod gage.

6.1.5.1 Connect the vacuum gage to the side tube of the temperature sensor/vacuum adapter of the distillation column (preferred location) or to the side tube of the sensor/vacuum adapter of the condenser when assembling the apparatus. Connections shall be as short in length as possible and have an inside diameter not less than 8 mm.

6.1.6 *Pressure Regulating System*, capable of maintaining the pressure of the system constant within 0.01 kPa at pressures of 1 kPa absolute and below and within 1 % of the absolute pressure at 1 kPa or higher. Suitable equipment for this purpose is described in Annex A4. Connect the pressure regulating system to the tube at the top of the condenser when assembling the apparatus. Connections shall be as short in length as possible and have an inside diameter not less than 8 mm.

6.1.7 *Vacuum Source*, consisting of, for example, one or more vacuum pumps and several surge tanks, capable of maintaining the pressure constant within 1 % over the full range of operating pressures. A vacuum adapter is used to connect the source to the top of the condenser (Fig. 1) with tubing of 8 mm ID or larger and as short as practical. A single stage pump of at least 850 L/min (30 cfm) capacity at 100 kPa

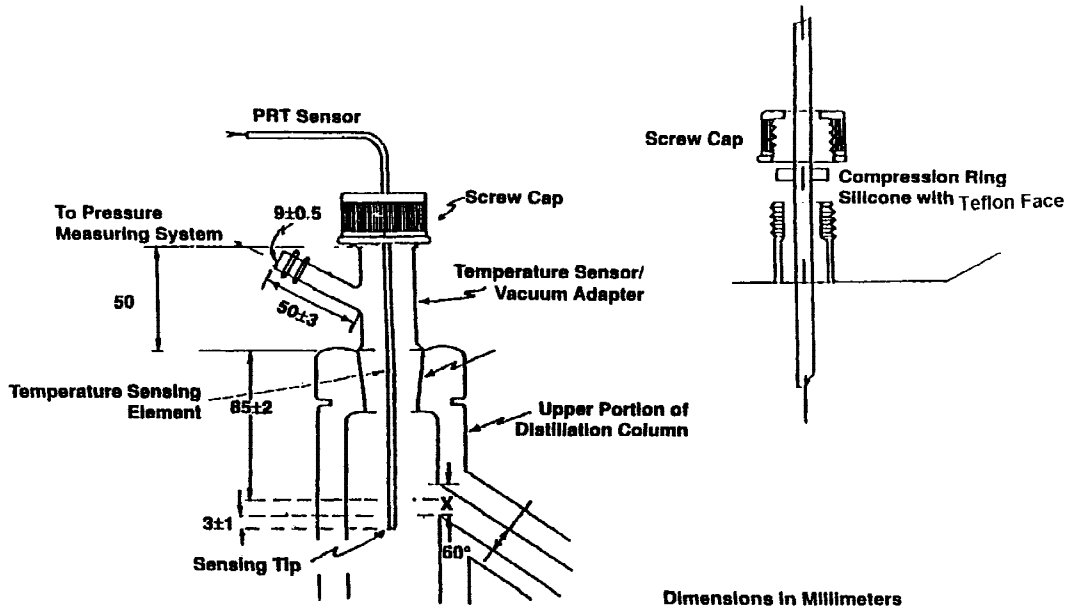

NOTE 1—Dimensions are in millimetres.
FIG. 6 Location of Temperature Sensor

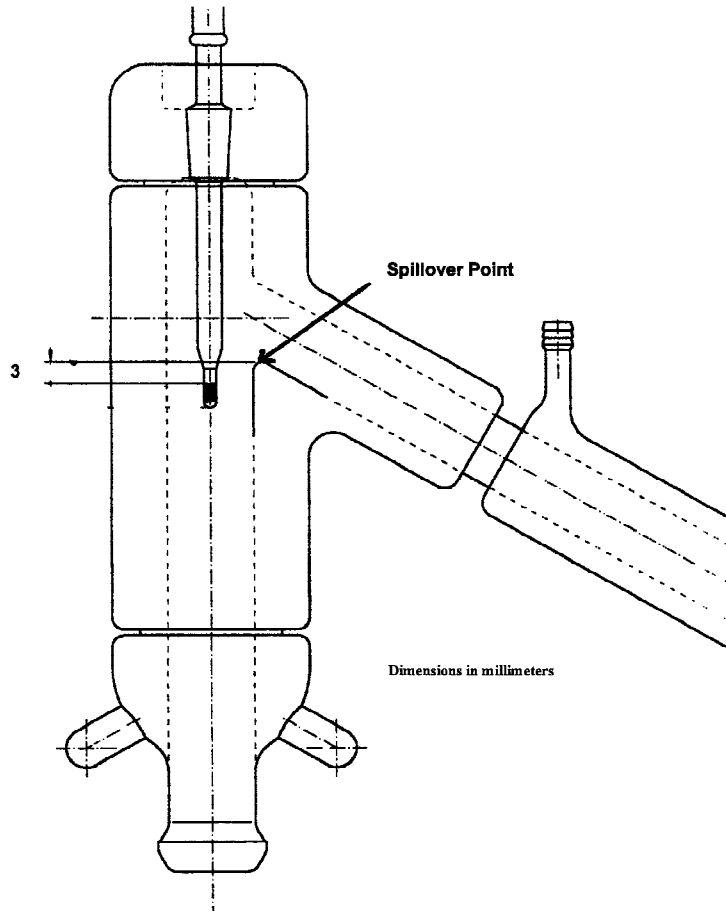

FIG. 7 Platinum Resistance Temperature Measuring Device

is suitable as a vacuum source, but a double stage pump of similar or better capacity is recommended if distillations are to

be performed below 0.5 kPa. Surge tanks of at least 5 L capacity are recommended to reduce pressure fluctuations.

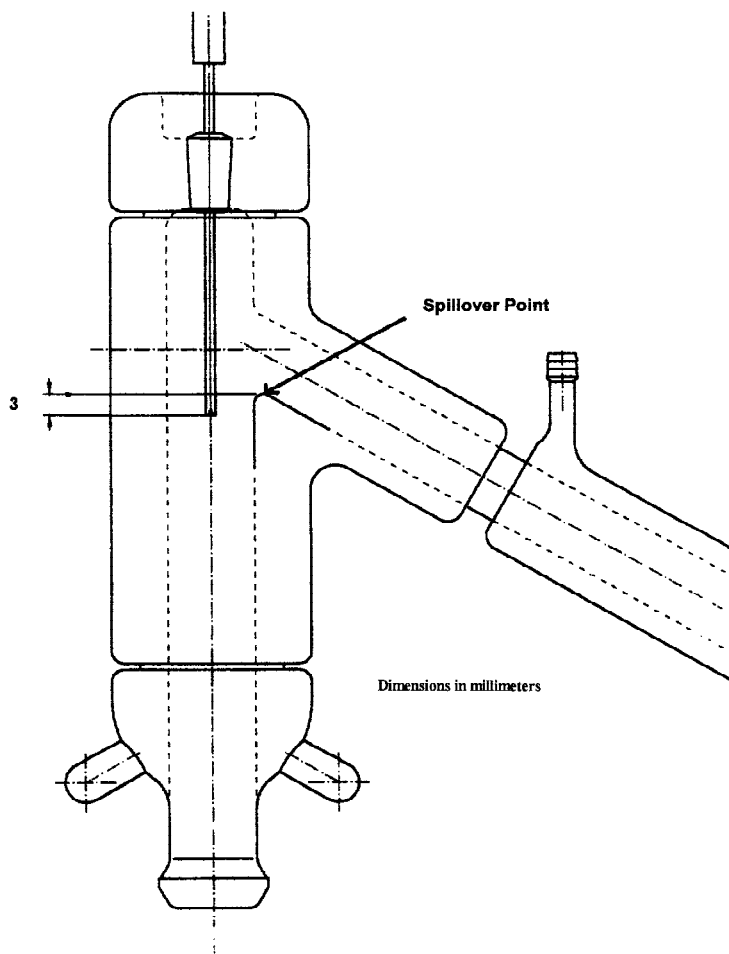

FIG. 8 Thermocouple Temperature Measuring Device

6.1.8 Cold Traps:

6.1.8.1 Cold trap mounted between the top of the condenser and the vacuum source to recover the light boiling components in the distillate that are not condensed in the condenser section. This trap shall be cooled with a coolant capable of maintaining the temperature of the trap below -40°C . Liquid nitrogen is commonly used for this purpose. (**Warning**—If there is a large air leak in the system and liquid nitrogen is used as the coolant, it is possible to condense air (oxygen) in the trap. If hydrocarbons are also present in the trap, a fire or explosion can result when the trap is warmed up in step 10.12.)

6.1.8.2 Cold trap mounted between the temperature sensor/vacuum adapter and the vacuum gage to protect the gage from contamination by low boiling components in the distillate.

6.1.9 Low Pressure Air or Carbon Dioxide Source to cool the flask and heater at the end of the distillation.

6.1.10 Low Pressure Nitrogen Source to release the vacuum in the system.

6.1.11 Safety Screen or Safety Enclosure that adequately shields the operator from the distillation apparatus in the event of mishap. Reinforced glass, 6 mm thick clear plexiglass, or a clear material of equivalent strength is recommended.

6.1.12 Coolant Circulating System, capable of supplying coolant to the receiver and condenser system, at a temperature controlled within $\pm 3^{\circ}\text{C}$ in the range between 30 and 80°C . For

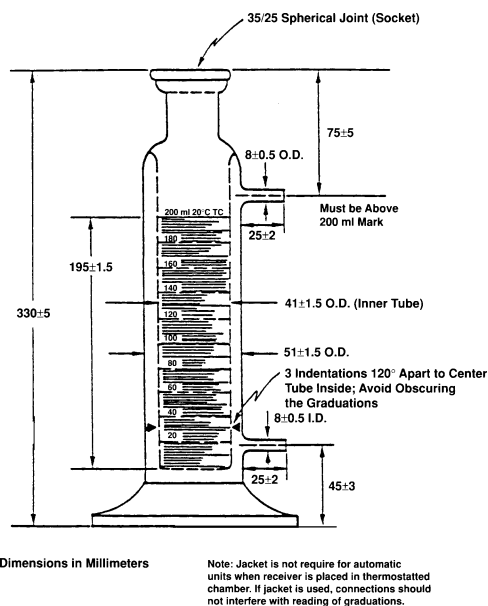

Dimensions in Millimeters

Note: Jacket is not required for automatic units when receiver is placed in thermostatted chamber. If jacket is used, connections should not interfere with reading of graduations.

NOTE 1—Jacket is not required for automatic units when receiver is placed in thermostatted chamber. If jacket is used, connections should not interfere with reading of graduations.

FIG. 9 Receiver

automatic units where the receiver is mounted in a thermostated chamber, the coolant circulating system has to be capable of supplying coolant to the condenser system only.

7. Reagents and Materials

7.1 *n-Tetradecane*—Reagent grade conforming to the specifications of the Committee on Analytical Reagents of the American Chemical Society.⁵

7.2 *ASTM Cetane Reference Fuel (n-Hexadecane)*, conforming to the specification in Test Method D 613.

7.3 *Silicone Grease*—High vacuum silicone grease specially manufactured for the use in high vacuum applications.

7.4 *Silicone Oil*, certified by the manufacturer to be applicable for prolonged use at temperatures above 350°C.

7.5 *Toluene*—Technical grade.

7.6 *Cyclohexane*—Technical grade.

8. Sample and Sampling Requirements

8.1 Sampling shall be done in accordance with Practices D 4057 or D 4177. It is assumed that a 4- to 8-L sample, representative of a shipment or of a plant operation, is received by the laboratory and that this sample is to be used for a series of tests and analyses. An aliquot portion slightly in excess of 200 mL will be required for this test method.

8.2 The aliquot used for this test shall be moisture-free. If there is evidence of moisture (drops on the vessel wall, a liquid layer on the bottom of the container, etc.) use the procedure given in Annex A6, paragraph A6.1, to dehydrate a sufficient quantity of sample to provide the 200-mL charge to the distillation flask.

8.3 Determine the density of the oil sample at the temperature of the receiver by means of a hydrometer by Practice D 1298, by means of a digital density meter by Test Method D 4052, and by using either the mathematical subroutines or tables of Guide D 1250, or a combination thereof.

8.4 If the sample is not to be tested immediately upon receipt, store at ambient temperature or below. If the sample is received in a plastic container, it shall be transferred to a container made out of glass or of metal prior to storage.

8.5 The sample shall be completely liquid before charging. If crystals are visible, the sample shall be heated to a temperature that permits the crystals to dissolve. The sample must then be stirred vigorously for 5 to 15 min, depending on the sample size, viscosity, and other factors, to ensure uniformity. If solids are still visible above 70°C, these particles are probably inorganic in nature and not part of the distillable portion of the sample. Remove most of these solids by filtering or decanting the sample.

8.5.1 There are several substances, such as visbroken residues and high melting point waxes, that will not be completely fluid at 70°C. These solids and semi-solids should not be removed since they are part of the hydrocarbon feed.

9. Preparation, Calibration, and Quantification of Apparatus

9.1 Calibrate the temperature sensors and associated signal conditioning and processing device as a unit in accordance with Annex A1.

9.2 Check the operation of the pressure regulating system as described in Annex A4.

9.3 Clean and dry the glass parts and relubricate the joints. Silicone high-vacuum grease can be used but no more than is necessary to give a uniform film on the ground glass surfaces. An excess of grease can cause leaks and can contribute to foaming at startup.

9.4 Assemble the empty apparatus and conduct a leak test as described in A3.3.2.

9.5 Check the total apparatus using either of the two reagents described in 7.1 and 7.2 and in accordance with Annex A5.

10. Procedure

10.1 Determine when the temperature sensor was last calibrated. Recalibrate according to Annex A1 if more time has elapsed than that specified in Annex A1.

10.2 Set the temperature of the condenser coolant to at least 30°C below the lowest vapor temperature to be observed in the test.

NOTE 3—A suitable coolant temperature for distillation of many materials is 60°C.

10.3 From the density of the sample determine the weight, to the nearest 0.1 g, equivalent to 200 mL of the sample at the temperature of the receiver. Weigh this quantity of oil into the distillation flask.

10.4 Lubricate the spherical joints of the distillation apparatus with a suitable grease (Note 4). Make certain that the surfaces of the joints are clean before applying the grease, and use only the minimum quantity required. Connect the flask to the lower spherical joint of the distilling head, place the heater under the flask, put the top mantle in place and connect the rest of the apparatus using spring clamps to secure the joints.

NOTE 4—Silicone high-vacuum grease has been used for this purpose. An excess of this lubricant applied to the flask joint can cause the sample to foam during distillation.

10.5 Place a few drops of silicone oil in the bottom of the thermowell of the flask and insert the temperature sensor to the bottom. The sensor can be secured with a wad of glass wool at the top of the thermowell.

10.6 Start the vacuum pump and observe the flask contents for signs of foaming. If the sample foams, allow the pressure on the apparatus to increase slightly until the foaming subsides. Apply gentle heat to assist the removal of dissolved gas. For general directions for suppression of excessive foaming of the sample, see A6.2.

10.7 Evacuate the apparatus until the pressure reaches the level prescribed for the distillation (Note 5). Failure to reach the distillation pressure, or the presence of a steady increase in pressure in the apparatus with the pump blocked off, is evidence of significant leakage into the system. Bring the system to atmospheric condition using a nitrogen bleed and

⁵ *Reagent Chemicals, American Chemical Society Specifications*, American Chemical Society, Washington, DC. For suggestions on the testing of reagents not listed by the American Chemical Society, see *Analar Standards for Laboratory Chemicals*, BDH Ltd., Poole, Dorset, U.K., and the *United States Pharmacopeia and National Formulary*, U.S. Pharmacopeial Convention, Inc. (USPC), Rockville, MD.

relubricate all joints. If this does not result in a vacuum-tight system, examine other parts of the system for leaks.

NOTE 5—The most commonly prescribed pressure is 1.3 kPa (10 mm Hg). For heavy products with a substantial fraction boiling above 500°C, an operating pressure of 0.13 kPa (1 mm Hg) or 0.26 kPa (2 mm Hg) is generally specified.

10.8 After the desired pressure level has been attained, turn on the heater and apply heat as rapidly as possible to the flask, without causing undue foaming of the sample. As soon as vapor or refluxing liquid appears at the neck of the flask, adjust the rate of heating so that the distillate is recovered at a uniform rate of 6 to 8 mL/min (Note 6).

NOTE 6—It is extremely difficult to achieve the desired rate at the very beginning of the distillation, but this rate should be attainable after the first 10 % of the distillate has been recovered.

10.9 Record the vapor temperature, time, and the pressure at each of the following volume percentage fractions of the charge collected in the receiver: IBP, 5, 10, 20, 30, 40, 50, 60, 70, 80, 90, 95, and at the end point. If the liquid temperature reaches 400°C, or if the vapor reaches a maximum temperature before the end point is observed, record the vapor temperature reading and the total volume recovered at the time the distillation is discontinued. When a product is tested for conformity with a given specification, record all requested observations, whether or not they are listed above.

NOTE 7—The maximum vapor temperature will result either from complete distillation of the oil or from the onset of cracking.

10.10 If a sudden increase in pressure is observed, coupled with the formation of white vapors and a drop in the vapor temperature, the material being distilled is showing significant cracking. Discontinue the distillation immediately and record the fact on the run sheet. If necessary, rerun the distillation with a fresh sample at lower operating pressure.

10.11 Lower the flask heater 5 to 10 cm and cool the flask and heater with a gentle stream of air or, preferably, with a stream of carbon dioxide (Note 8). Repressure the contents of the still with dry nitrogen (**Warning**—Repressuring the contents of the still with air while it contains hot oil vapors can result in fire or explosion.) if it is necessary to dismantle the apparatus before it has cooled below 200°C. Carbon dioxide can also be used for repressuring, provided liquid nitrogen traps are not in use. (**Warning**—In addition to other precautions, it is recommended to discontinue the distillation at a maximum vapor temperature of 350°C. Operating the distillation flask at temperatures above 350°C for prolonged periods at pressures below 1 kPa may also result in thermal deformation of the flask. In this case, discard the flask after use. Alternatively, use a quartz flask.)

NOTE 8—A gentle stream of carbon dioxide is preferred to cool the flask to prevent fire in the event the flask cracks during the test or during the cooling cycle.

10.12 Bring the temperature of the cold trap mounted before the vacuum source back to ambient temperature. Recover, measure, and record the volume of the light products collected in the trap.

10.13 Remove the receiver and replace with another. Remove the flask and replace with another flask filled with a

cleaning solvent (Note 9). Run a distillation at atmospheric pressure to clean the unit. At the end of this cleaning run, remove the flask and receiver and blow a gentle stream of air or nitrogen to dry the unit.

NOTE 9—Toluene or cyclohexane can be used as cleaning solvent.

11. Calculations and Report

11.1 Convert the recorded vapor temperature readings to Atmospheric Equivalent Temperatures (AET) using the equations in Annex A7.

11.2 Report the AET to the nearest degree Celsius corresponding to the volumetric percentages of liquid recovered in the receiver. Report also the identity of the sample, the density (measured in 8.3), the total amount of liquid distillate recovered in the receiver and in the cold trap before the vacuum source, any unusual occurrence such as foaming or burping, together with the measures that were taken to correct the problem.

12. Precision and Bias ⁶

12.1 *Precision*—The precision of this test method was generated from data obtained in a 1983 cooperative interlaboratory program with nine laboratories participating and eight samples being run. In this program, one laboratory used an automatic vacuum distillation analyzer and the results obtained with this equipment have been included in the data used to generate this precision statement. The precision of this test method is as follows:

12.1.1 *Repeatability*—The difference between two test results, in degrees Celsius, obtained by the same operator with the same apparatus under constant operating conditions on identical test materials would, in the long run, in the normal and correct operation of this test method, exceed the values indicated in Table 2 in only 1 case in 20.

12.1.2 *Reproducibility*—The difference between two single and independent results in degrees Celsius, obtained by different operators working in different laboratories on identical test material would, in the long run, in the normal and correct operation of this test method, exceed the values indicated in Table 2 in only 1 case in 20.

12.1.3 In Table 2, the rate of change in degrees Celsius (AET) per percentage of liquid volume recovered is shown as C/V %. At any point between the 10 and the 90 % point this value is assumed to be equal to the average value of C/V % of the two data points that bracket the point in question. In no case shall the span of these two points be more than 20 % recovered. An exception is the 5 % point where the span shall be not more than 10 %. See Annex A8 for an example.

12.2 The precision data in Table 2 have been computed from the following equations, which can be used to calculate precision data for C/V % values not listed.

12.2.1 Repeatability (r) can be calculated using the following equation:

$$r = M[e \exp\{a + b \ln(1.8 S)\}]/1.8 \quad (1)$$

⁶ Supporting data are available from ASTM International Headquarters. Request RR:D02-1206.



TABLE 2 Precision

NOTE 1—The body of this table is in degrees Celsius atmospheric equivalent temperature.

Criteria Pressure	Repeatability				Reproducibility			
	0.13 kPa (1 mm Hg)		1.3 kPa (10 mm Hg)		0.13 kPa (1 mm Hg)		1.3 kPa (10 mm Hg)	
IBP	17		15		56		49	
FBP	3.3		7.1		31		27	
Volume Recovered	5–50 %	60–90 %	5–50 %	60–90 %	5–50 %	60–90 %	5–50 %	60–90 %
	<i>C/V %</i>							
0.5	2.4	2.5	1.9	2.0	6.5	3.9	7.0	5.4
1.0	2.9	3.0	2.4	2.5	10	6.0	9.3	7.2
1.5	3.2	3.3	2.8	2.9	13	7.8	11	8.5
2.0	3.4	3.5	3.1	3.2	16	9.4	12	9.6
2.5	3.6	3.7	3.3	3.5	18	11	14	11
3.0	3.8	3.9	3.6	3.7	21	12	15	11
3.5	3.9	4.0	3.8	3.9	23	13	16	12
4.0	4.0	4.2	3.9	4.1	25	15	16	13
4.5	4.1	4.3	4.1	4.3	27	16	17	13
5.0	4.2	4.4	4.3	4.4	29	17	18	14
5.5	4.3	4.5	4.4	4.6	30	18	19	15
6.0	4.4	4.6	4.5	4.7	32	19	19	15
6.5	4.5	4.7	4.7	4.8	34	20	20	16
7.0	4.6	4.8	4.8	5.0	35	23	21	16
7.5	4.7	4.8	4.9	5.1	37	22	21	16
8.0	4.8	4.9	5.0	5.2	38	23	22	17
8.5	4.8	5.0	5.1	5.3	40	24	22	17
9.0	4.9	5.1	5.2	5.4	41	25	23	18
9.5	5.0	5.1	5.3	5.5	43	25	23	18
10.0	5.0	5.2	5.4	5.6	44	26	24	19
10.5	5.1	5.2	5.5	5.7	46	27	24	19
11.0	5.1	5.3	5.6	5.8	47	28	25	19
11.5	5.2	5.4	5.7	5.9	48	29	25	20
12.0	5.2	5.4	5.8	6.0	50	30	26	20
12.5	5.3	5.5	5.9	6.1	51	30	26	20
13.0	5.3	5.5	6.0	6.2	52	31	27	21
13.5	5.4	5.6	6.0	6.3	54	32	27	21
14.0	5.4	5.6	6.1	6.3	55	33	27	21
14.5	5.5	5.7	6.2	6.4	56	33	28	22
15.0	5.5	5.7	6.3	6.5	57	34	28	22

where:

- r = repeatability, °C (AET),
- e = base of natural logarithmic function, approximately 2.718281828,
- $a, b,$ and M = constants from 12.5.1, and
- S = rate of temperature change (°C, AET) per volume percent recovered.

12.2.2 Reproducibility (R) can be calculated using the following equation:

$$R = M'[e \exp\{a' + b' \ln(1.8 S)\}]/1.8 \quad (2)$$

where:

- R = reproducibility, °C (AET),
- $a', b',$ and M' = constants from 12.5.2, and
- S = rate of temperature change (°C, AET) per volume percent recovered.

12.2.3 See Annex A8 for an example.

12.3 To calculate precision data for pressures between 0.13 and 1.3 kPa (1 and 10 mm Hg), use constants calculated by linear interpolation from data given in 12.5.1 and 12.5.2.

12.4 *Bias*—Since there is no accepted reference material suitable for determining the bias for the procedure in this test method, no statement is being made.

12.5 *Constants for Calculating:* See Table 2.

12.5.1 Constants for calculating repeatability (r):

		IBP	Volume Recovered		FBP
			5–50 %	60–95 %	
At 0.13 kPa (1 mm Hg)	a	2.372	0.439	0.439	0.718
	b	0	0.241	0.241	0
	M	2.9	2.9	3.0	2.9
At 1.3 kPa (10 mm Hg)	a	2.246	0.240	0.240	1.521
	b	0	0.350	0.350	0
	M	2.8	2.8	2.9	2.8

12.5.2 Constants for calculating reproducibility (R):

		IBP	Volume Recovered		FBP
			5–50 %	60–95 %	
At 0.13 kPa (1 mm Hg)	a'	3.512	1.338	0.815	2.931
	b'	0	0.639	0.639	0
	M'	3.0	3.3	3.3	3.0
At 1.3 kPa (10 mm Hg)	a'	3.424	1.415	1.190	2.815
	b'	0	0.409	0.409	0
	M'	2.9	3.2	3.1	2.9

13. Keywords

13.1 atmospheric equivalent temperature (AET); boiling range; distillation; vacuum distillation

ANNEXES

(Mandatory Information)

A1. PRACTICE FOR CALIBRATION OF TEMPERATURE SENSORS

A1.1 *Principle*—This section of the annex deals with the basic calibration of the vapor temperature sensor against primary temperature standards as recommended by the National Institute for Science and Technology (NIST) in order to avoid the problems associated with the use of secondary temperature references. It can also be used for the calibration of other temperature sensors.

A1.2 Sensors should be calibrated over the full range of temperatures at the time of first use and whenever the sensor or its associated instrument is repaired or serviced. Sensors used in vapor temperature service should be checked monthly at one or more temperatures.

A1.3 Calibrate the sensors with their associated instruments by recording the temperatures of the freezing points of water and of the selected pure metals and metal blends listed in A1.6.

A1.4 *Apparatus*—A suitable apparatus is shown in Fig. A1.1. For the freezing point of water, a Dewar flask filled with at least 50 % crushed ice in water may be substituted.

A1.5 Procedure:

A1.5.1 For sensors that are mounted loosely in a thermowell, place enough silicone oil or other inert liquid in the bottom of the well so as to make good physical contact between the sensor and the tip of the well. Those sensors that are fused into good contact with the tip of the well may be calibrated as is.

A1.5.2 Place about 0.3 mL of silicone oil in the bottom of the thermowell of the melting point bath and insert the sensors to be calibrated. The oil must cover the tips.

A1.5.3 Heat the melting point bath to a temperature 5 to 10°C above the melting point of the metal inside and hold at this temperature for 5 min to ensure that all the metal inside is melted.

A1.5.4 Discontinue heat to the melting point bath and observe and record the cooling curve. A paper strip chart recorder is recommended. When the cooling curve shows a plateau of constant temperature for at least 1 min, the temperature of the recorded plateau is accepted as the calibration temperature.

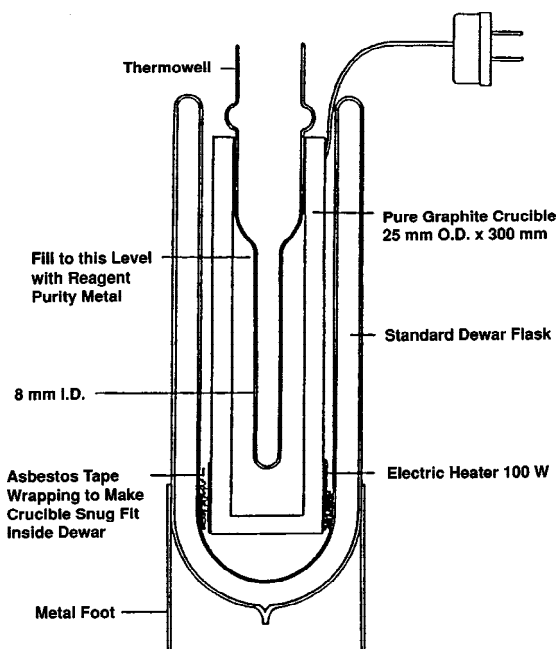

FIG. A1.1 Melting Point Bath for Temperature Standards

A1.5.5 Apply a correction to be added to the reading, if necessary, to give the correct temperature. A chart may be drawn of correction versus temperature for interpolation. In the case of automated instruments, the correction must be built into the record and must be adjustable.

A1.5.6 If the freezing plateau is too short, it can be increased by applying some heat during the cooling cycle. Be aware of the possibility that the metal bath can become contaminated or too oxidized. In this case, replace the metal.

A1.6 Reagents and Materials:

A1.6.1 *Distilled Water*—Reagent grade as defined by Type III of Specification D 1193, freezing point 0.0°C.

A1.6.2 *Metals Blend of Sn 50 wt %, Pb 32 wt %, Cd 18 wt %*—Freezing point 145.0°C.

A1.6.3 *Sn*—100 %, freezing point 231.9°C.

A1.6.4 *Pb*—100 %, freezing point 327.4°C.

A2. PRACTICE FOR DETERMINATION OF TEMPERATURE RESPONSE TIME

A2.1 *Scope*—This practice is for the determination of the temperature response time based on the rate of cooling of the sensor under prescribed conditions.

A2.2 *Significance and Use*—This practice is performed to

ensure that the sensor is able to respond sufficiently rapidly to changes in temperature that no significant error due to lag is introduced in a rapidly rising temperature curve.

A2.2.1 The importance of this test is greatest under the lowest pressure conditions when the heat content of the vapors is minimal.

A2.3 Procedure:

A2.3.1 Arrange a 1-L beaker of water on a hot plate with a glass thermowell supported vertically in the water. Maintain the temperature of the water at $90 \pm 5^\circ\text{C}$.

A2.3.2 Connect the sensor to a suitable instrument preferably having a digital readout with a readability to 0.1°C . Alternatively, connect the sensor to a strip chart recorder of suitable range that will allow interpolation to 0.1°C . Set the chart speed to at least 30 cm/h for ease of reading.

A2.3.3 Insert the sensor into a hole in the center of one side of a cardboard cube box of about 30 cm in each dimension. The sensor should be held in place by friction fit of the joint in the hole. Record the temperature in the box when it becomes stable.

A2.3.4 Remove the sensor and insert it into the thermowell in the beaker of water. After the sensor has reached a temperature of 80°C , remove it and immediately insert it into the hole in the box.

A2.3.5 Observe with a stopwatch, or record on the strip-chart, the time interval required by the sensor to cool from 30°C above to 5°C above the temperature recorded in A2.3.3.

A2.3.6 A time interval in excess of 200 s is not acceptable.

A3. PRACTICE FOR CALIBRATION OF VACUUM GAGES

A3.1 *Principle*—The calibration of vacuum sensors is based upon the use of the McLeod gage, which is the only practical primary gage suitable for this pressure range.

NOTE A3.1—The general principles of construction of McLeod gages are well-established. The dimensions and tolerances of a gage that, when properly employed, fulfills the requirements of 6.1.5 for the pressure range from 0.1 to 5 kPa are: capillary length of 200 ± 5 mm, capillary diameter of 2.7 mm (known to 0.002 mm), bulk volume + capillary volume, 10.5 ± 0.5 mL (known to 0.05 mL). This gage is best used by adjusting the mercury level in the system pressure arm to a point opposite the closed end of the capillary tube. The system pressure is calculated by means of the following equation:

$$P = Kbh^2 / (V - bh) \quad (A3.1)$$

where:

K = 133.32. This is a dimensioned conversion factor to convert mm to N/m^2 ,

P = system pressure, Pa,

b = volume of capillary per unit of length expressed as mL/mm,

h = length of capillary left unfilled by mercury, mm, and

V = combined volume of bulb and capillary, mL.

This equation includes the correction term required when the system pressure is an appreciable fraction of the length of the capillary left unfilled with mercury. A requirement for the successful operation of this gage to measure system pressures in the range from 100 Pa to 200 Pa (0.75 mm Hg to 1.5 mm Hg) is the determination of the length of capillary left unfilled with mercury with an accuracy of 0.2 mm. At pressures from 0.2 to 2 kPa (1.5 to 15 mm Hg), a precision in this measurement of 0.5 mm is sufficient.

A3.2 *Apparatus*—A suitable test setup is shown in Fig. A3.1. It must be capable of maintaining pressures that are steady within 1 % of the required pressure at pressures of 1 kPa and higher and within 0.01 kPa at pressures below 1 kPa.

A3.2.1 The McLeod gage, when used as the standard, must have been baked out hot and empty at a pressure below 0.01 kPa before refilling with clean mercury and thereafter be protected from exposure to moisture such as that from atmospheric air. The use of two McLeod gages of different pressure

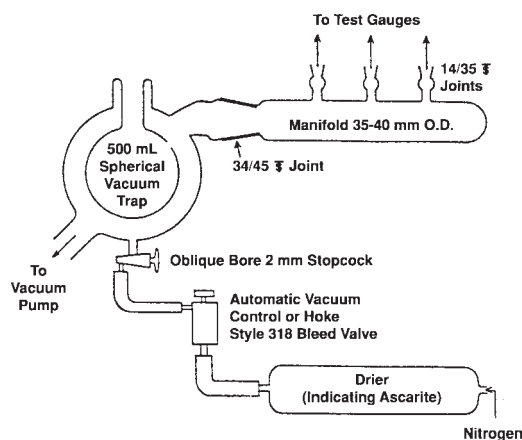

FIG. A3.1 Calibration of Vacuum Gages

ranges is recommended as a precaution. If they agree at the test pressure, it is an indication that the system is free of moisture and other condensibles. (**Warning**—Hg is a poison. Harmful or fatal if inhaled or ingested.)

A3.3 Procedure:

A3.3.1 Set up a test manifold such as that shown in Fig. A3.1.

A3.3.2 Ensure that the test manifold is leak-free and can be maintained at a steady pressure at the required level. A suitable leak test is to pump down to a pressure below 0.1 kPa and isolate the pump. Observe the pressure inside the unit for at least 1 min. If the pressure rises no more than 0.01 kPa in that period, the apparatus is considered acceptable.

A3.3.3 Connect the primary vacuum gage(s) and the gage(s) to be calibrated. Adjust the pressure to the required level for the test and run a final leak test as above.

A3.3.4 Read and record the pressures indicated by all the gages as nearly simultaneously as possible.

A3.3.5 Repeat the above procedure at the pressure levels 0.13, 1.3, and 6.7 kPa (1, 10, and 50 mm Hg).

A3.3.6 Make up a chart of corrections to be added at each pressure level for each gage tested. This can be used for interpolation when necessary.

A4. PRESSURE REGULATING SYSTEM

A4.1 The following is suggested as a satisfactory example of a pressure regulating system: A low-efficiency, high-capacity vacuum pump is connected to one of two surge tanks, each having a capacity of 10 to 20 L and arranged in series. A solenoid valve or other type regulator is installed in the connection between the tanks so that the first tank is maintained at pump pressure and the second one at the pressure of the distillation apparatus.

A4.1.1 With some apparatus it is desirable to have a slight bleed to the second tank that will cause the controls to operate at regular intervals in order to provide smooth operation. However, experience has shown that the bleed shall be held at an absolute minimum in order to prevent loss of vapors through the manometer connection at the top of the column.

A4.1.2 Connecting lines from the second tank to the vacuum distillation apparatus shall be as short in length and as large in diameter as possible. A minimum internal diameter of 12 mm is suggested.

A4.1.3 For multiple still arrangements, it is possible to use a large pump and a large low-pressure surge tank. Several smaller tanks operating at the pressures of the various distillations can be attached to the large low-pressure surge tank with individual pressure regulators. Other arrangements can be used, provided the pressure is maintained constant within the limits specified in 6.1.7.

NOTE A4.1—If a solenoid valve or other electrically operated regulator is used, a suitable manostat is required for activation of the regulating device. Many such manostats are described in the literature or are available from laboratory supply houses. As an alternative for the separate manostat and solenoid, a Cartesian Manostat can be used. This device is capable of maintaining the system pressure within the specified limits down to a pressure of about 1 kPa.

A5. APPARATUS CHECK WITH REAGENT FUEL

A5.1 Check the assembled apparatus, including the previously calibrated pressure measuring and temperature sensor and associated instrumentation, to indicate proper assembly and operating control. Conduct the test procedure as described at the test pressure in connection with a specific sample or at two or more pressures in connection with general checks of the equipment, using *n*-hexadecane or *n*-tetradecane.

A5.1.1 If *n*-hexadecane is used, the average of distillation temperatures obtained in the 10 % to 90 % range, inclusive, should conform with the data in Table A5.1.

A5.1.2 For pressures over 0.1 kPa not given in Table A5.1, the range of average temperatures shall not deviate by more than 1.5°C from a temperature, *t*, given by:

$$t = [1831.316/(6.14438 - \log P)] - 154.53 \quad (\text{A5.1})$$

where *P* is in kPa, and *t* is in °C, or

$$t = [1831.316/(7.01944 - \log P)] - 154.53 \quad (\text{A5.2})$$

where *P* is in mm Hg, and *t* is in °C.

A5.1.3 If *n*-tetradecane is used, the average of distillation temperatures obtained in the 10 % to 90 % range, inclusive, should conform with the data in Table A5.1.

A5.1.4 For pressures over 0.1 kPa not given in Table A5.1, and if *n*-tetradecane is used, the range of average temperatures shall not deviate by more than 1.5°C from a temperature, *t*₁₄, given by:

$$t_{14} = [1747.452/(6.1471 - \log P)] - 168.44 \quad (\text{A5.3})$$

where *P* is in kPa, and *t* is in °C, or

$$t_{14} = [1747.452/(7.02216 - \log P)] - 168.44 \quad (\text{A5.4})$$

where *P* is in mm Hg, and *t* is in °C.

TABLE A5.1 Distillation Temperatures of Reference Compounds

Pressure		Range of Temperatures, °C	
kPa	mm Hg	<i>n</i> -tetradecane	<i>n</i> -hexadecane
0.13	1.0	78.9 to 81.9	104.3 to 107.6
0.67	5.0	106.4 to 109.4	133.1 to 136.4
1.34	10.0	120.2 to 123.2	147.5 to 150.8
2.7	20.0	135.5 to 138.5	163.3 to 166.7
5.3	40.0	152.5 to 155.5	181.1 to 184.4
6.7	50.0	158.3 to 161.3	187.2 to 190.6

A6. SAMPLE DEHYDRATION AND FOAMING SUPPRESSION

A6.1 *Dehydration of Sample*—The following is suggested as a convenient means of dehydrating samples to be subjected to this distillation test. Heat 300 mL of the sample to 80°C, add 10 to 15 g of 8- to 12-mesh fused calcium chloride (CaCl₂), and stir vigorously for 10 to 15 min. Allow the mixture to cool without stirring, and remove the oil layer by decantation.

A6.2 *Suppression of Foaming and Bumping of the Sample:*

A6.2.1 The tendency of samples to bump or foam excessively is frequently a serious obstacle to the successful distillation of petroleum products under vacuum. In some cases, this is due to the presence of water or dissolved gases, but many samples foam even when apparently free from these contaminants. There is no unanimity of opinion concerning the best way to reduce excessive foaming to manageable proportions. The following methods are offered solely as examples of means that have been employed successfully for that purpose.

A6.2.2 *Degassing*—The procedure described in 10.6 is intended to promote degassing. Slow rates of pressure reduction or temperature increase, or both, for the oil in the flask are important factors in achieving success by this means. Another technique for degassing is to filter the sample under vacuum before weighing.

A6.2.3 *Application of Steel Wool*—Separate about 10 g of a folded pad of median-grade steel wool. Unfold, and separate into 8 to 10 long, loose strands. Push each strand separately into the bulk of the flask. Avoid packing tightly or forming large void spaces. Fill the upper half of the bulb with steel

wool, but do not allow any strand to protrude more than 6 mm into the neck of the flask. Alternatively, take 0.5 to 0.6 g of Grade 2 steel wool, roll into five balls, each approximately 8 to 10 mm in diameter, and drop into the flask.

A6.2.4 *Boiling Chips*—These consist of broken pieces of porcelain drying plates or broken alundum thimbles that are dropped into the flask before starting a distillation. Hengar granules of the plain type, as used in Kjeldahl nitrogen determinations, are also used in the same way (Note A6.1).

NOTE A6.1—The use of anti-bumping aids can affect the distillation curve. Their use should therefore be limited to cases where they are absolutely needed to perform the distillation.

A6.2.5 *Silicone Fluids*—The addition of one or two drops of silicone fluid⁷ (350 cSt) to the sample in the flask is effective in the suppression of foam in many cases. However, analytical tests run on the products from this test method can be biased by the presence of these fluids, so the report shall make note of their use.

A6.2.6 *Flask Preparation*—Some laboratories have treated the inside of the flask, prior to use for distillation, in order to provide an active ebullition surface. Methods used for this purpose include: boiling 100 mL of 33 % sodium hydroxide solution for 15 to 20 min, etching of the inside of the flask bottom with hydrofluoric acid fumes, and the infusion of fine carborundum or fritted glass to the inside of the flask bottom.

⁷ Dow Corning Silicone Fluid No. 200, available from Dow Corning, has been found satisfactory for this purpose.

A7. PRACTICE FOR CONVERTING OBSERVED VAPOR TEMPERATURES TO ATMOSPHERIC EQUIVALENT TEMPERATURES (AET)

A7.1 Scope

A7.1.1 This practice is for conversion of the actual distillation temperature obtained at sub-ambient pressure to atmospheric equivalent temperature (AET) corresponding to the equivalent boiling point at atmospheric pressure, 101.3 kPa (760 mm Hg), by means of equations derived by Maxwell and Bonnell.⁸

A7.2 Significance and Use

A7.2.1 Final data on atmospheric equivalent temperatures are to be obtained by computation.

A7.3 Calculation

A7.3.1 Convert observed vapor temperature to atmospheric equivalent temperature using Eq A7.1:

$$AET = \frac{748.1A}{[1/(T + 273.1)] + 0.3861A - 0.00051606} - 273.1 \quad (A7.1)$$

where:

AET = atmospheric equivalent temperature, °C, and

T = observed vapor temperature, °C.

A7.3.1.1 Calculate A using Eq A7.2 or Eq A7.3:

$$A = \frac{5.143222 - 0.972546 \log_{10} P}{2579.329 - 95.76 \log_{10} P} \quad (A7.2)$$

where:

P = operating pressure, kPa, (operating pressure ≥ 0.266 kPa), or

$$A = \frac{5.994295 - 0.972546 \log_{10} P}{2663.129 - 95.76 \log_{10} P} \quad (A7.3)$$

where:

P = operating pressure, mm Hg (operating pressure ≥ 2 mm Hg).

A7.3.1.2 If the operating pressure < 0.266 kPa (< 2 mm Hg), calculate A using Eq A7.4 or Eq A7.5:

$$A = \frac{5.897249 - 0.987672 \log_{10} P}{2962.909 - 43.00 \log_{10} P} \quad (A7.4)$$

where:

⁸ Maxwell and Bonnell, *Industrial Engineering Chemistry*, Vol 49, 1957, p. 1187.

ASTM D 1160 – 02a

P = operating pressure, kPa, or

$$A = \frac{6.761559 - 0.987672 \log_{10} P}{3000.538 - 43.00 \log_{10} P} \quad (A7.5)$$

where:

P = operating pressure, mm Hg.

A7.3.2 The equations are correct only for specimens that have a Watson K -factor of 12.0 ± 0.2 . The K -factor shall be assumed to be 12 and any effect of K -factor ignored unless there is mutual agreement to the contrary.

A7.3.3 If correction is required, calculate the K -factor using Eq A7.6:

$$K = \frac{\sqrt[3]{1.8(B + 273.1)}}{D} \quad (A7.6)$$

where:

B = mean average boiling point, °C, and

D = density at 15°C.

A7.3.3.1 By custom, either the mid-point vapor temperature of the specimen or the mid-point of a gas chromatographic distillation of the specimen can be used for the mean average boiling point. In either case the method must be specified.

A7.3.3.2 An estimate of the K -factor can be made using Fig. A7.1.

A7.3.4 Calculate the correction to be applied to the AET using Eq A7.7:

$$t = -1.4[K - 12] \left[\log_{10} \left(\frac{P_a}{P_o} \right) \right] \quad (A7.7)$$

where:

t = correction, °C,

P_a = atmospheric pressure, kPa (mm Hg), and

P_o = observed pressure, kPa (mm Hg).

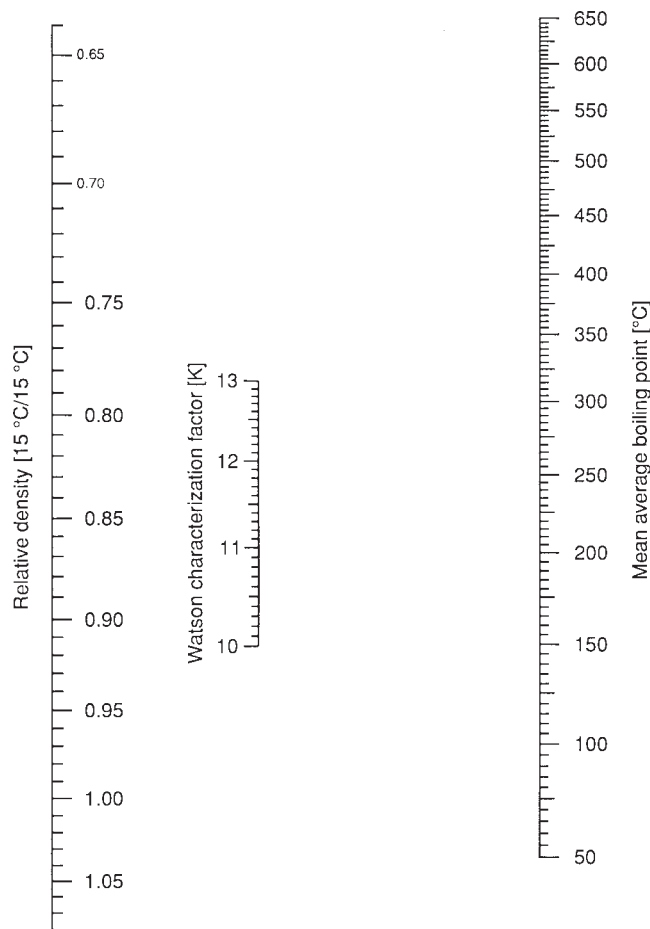

FIG. A7.1 Watson Characterization Factor of Petroleum Fractions

A7.3.4.1 An estimate of the correction can be made using Fig. A7.2.

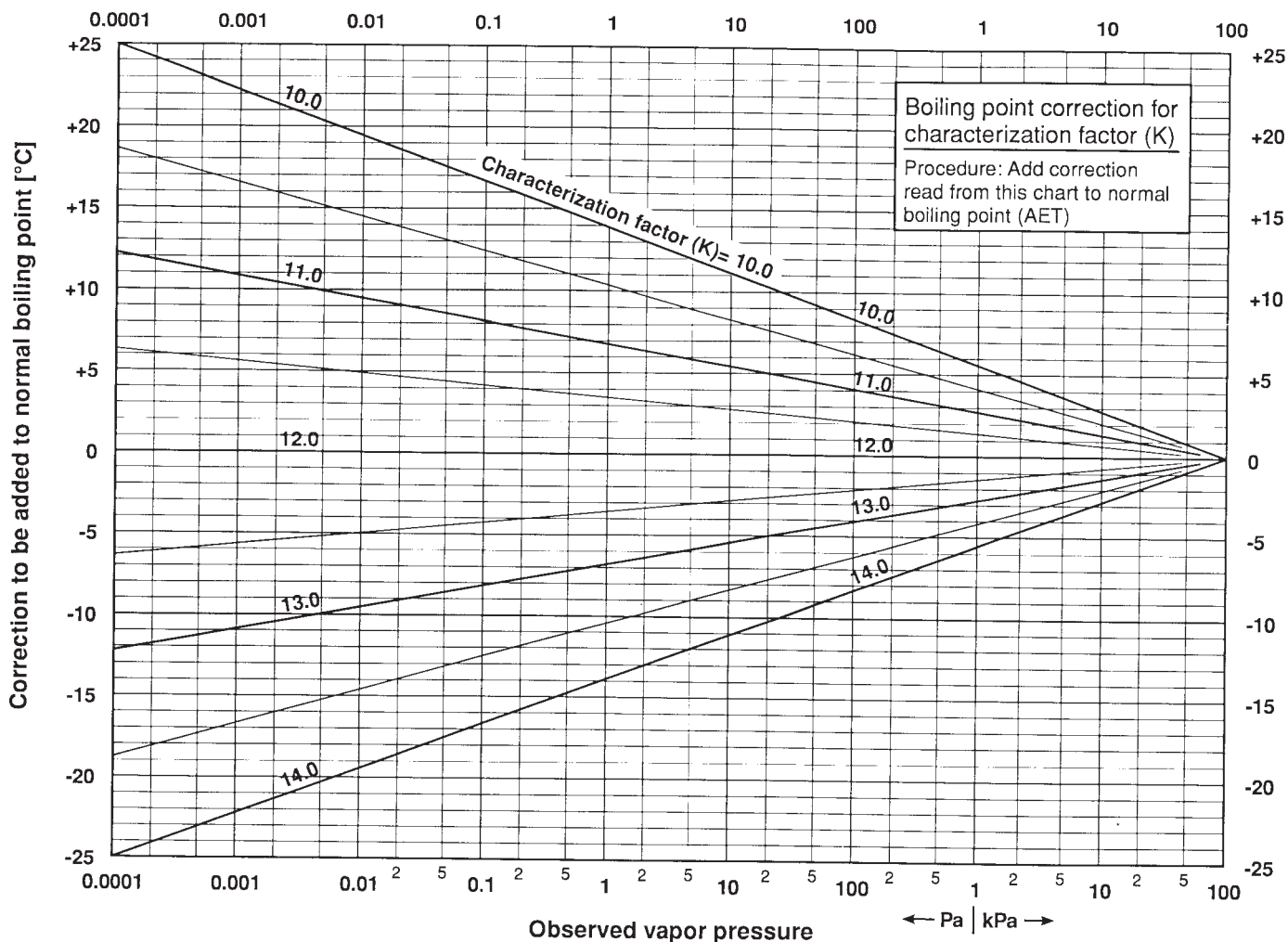

FIG. A7.2 Boiling Point Corrections for K-Factor

A8. EXAMPLE OF PRECISION CALCULATIONS

A8.1 Procedure:

A8.1.1 For a given percentage recovered from a distillation at a given pressure (0.13 or 1.3 kPa), calculate the change in temperature per volume percent recovered {°C(AET)/V %}.

A8.1.2 Look up the desired precision (repeatability or reproducibility) from Table 2. Use linear interpolation to find the precision when °C(AET)/V % is not a whole number.

A8.2 Example—Desired result: reproducibility of 30 % recovered, 0.13 kPa (1 mm Hg), °C:

AET (°C) 40 % 443

AET (°C) 30 % 427

AET (°C) 20 % 409

$$^{\circ}\text{C}/\text{V} \% = (443 - 409)/(40 - 20) = 34/20 = 1.7$$

From Table 2, Reproducibility, 0.13 kPa (1 mm Hg); recovery between 5 and 50 % (inclusive):

°C/V % of 1.5 = 13

°C/V % of 2.0 = 16

Therefore: $13 + (0.2/0.5)(16 - 13) = 14.2$, rounded = 14°C.

A9. DISTILLATION OF PETROLEUM PRODUCTS AT REDUCED PRESSURE (AUTOMATIC)

A9.1 *Scope*—This test method covers the determination by automatic equipment, at reduced pressures, of the range of boiling points for petroleum products that can be partially or completely vaporized at a maximum liquid temperature of 400°C.

A9.2 *Summary of Test Method*—The sample is distilled in an automatic distillation apparatus that duplicates the distillation conditions described in the manual procedure. Data are obtained from which the initial boiling point (IBP), the final boiling point (FBP), and a distillation curve of atmospheric equivalent temperature (AET) versus volume can be obtained.

A9.3 *Apparatus*—The automatic apparatus should be designed to include the components as described in 6.1. Additional parts not specified can be included by the manufacturer that are not essential for obtaining satisfactory results but are desirable components to the assembly for the purpose of promoting efficient use of the apparatus and ease of operation.

A9.3.1 *Level Follower/Recording Mechanism* for the measurement of the volume of liquid recovered in the receiver. The system shall have a resolution of 0.1 mL with an accuracy of ± 1 mL. The calibration of the assembly should be confirmed according to the manufacturer's instructions.

A9.3.2 *Vacuum Gage*, capable of measuring the absolute pressure with an accuracy of ± 10 Pa (± 0.08 mm Hg) at 1 kPa (7.5 mm) and below. The vacuum gage is usually an electronic pressure measuring system. An accuracy of ± 1 % of the observed reading is required in the range above 1 kPa. Electronic diaphragm gages are capable of achieving this level of accuracy, but they must be properly calibrated and rechecked periodically, as described in Annex A3.

A9.3.3 *Receiver Chamber Temperature Control System*, capable of controlling the receiver temperature between 32°C and 78°C.

A9.4 *Sample and Sample Requirements*—Sample and sampling requirements are described in Section 8.

A9.5 *Preparation of Apparatus*—The instrument is prepared in accordance with the manufacturer's instructions.

A9.6 Procedure:

A9.6.1 Set the temperature of the condenser coolant to at least 30°C below the lowest vapor temperature to be observed in the test. A temperature near 60°C has been found satisfactory for most charges.

A9.6.2 Determine the density of the sample at the temperature of the receiver by means of a hydrometer by Test Method D 1298, by means of a digital density meter using Test Method D 4052, or by using either the mathematical subroutines or tables of Guide D 1250, or a combination thereof.

A9.6.3 From the density of the sample, determine the weight, to the nearest 0.1 g, equivalent to 200 mL of the sample at the temperature of the receiver. Weigh this quantity of oil into the distillation flask.

A9.6.4 Lubricate the spherical joints of the distillation apparatus with a suitable grease. Connect the flask to the lower spherical joint of the distilling head, place the heater under the flask, put the top mantle in place, and connect the rest of the apparatus using spring clamps to secure the joints.

A9.6.5 Insert the temperature sensor into the thermowell of the flask.

A9.6.6 Set the operating pressure to the prescribed value for the distillation (see Note 3). The pressure should be automatically reduced in stages to prevent foaming of the sample.

A9.6.7 Set the initial heat rate to the desired value. The apparatus should have the capability to adjust heat input so that the distillate recovered is at a uniform rate of 6 to 8 mL/min.

A9.6.8 After ensuring that the apparatus controls are set according to the manufacturer's instructions, initiate the distillation.

A9.6.9 The apparatus will automatically record the initial boiling point, final boiling point, percent volumes recovered with corresponding actual temperatures, and distillation rates. Actual temperatures recorded are automatically converted to Atmospheric Equivalent Temperatures (AET) using software supplied by the manufacturer. This conversion should be based on (Eq A7.1).

A9.6.10 If the liquid temperature reaches 400°C, or if the vapor temperature reaches a maximum before the end point is observed, the distillation equipment shall switch off and terminate the distillation. The apparatus shall automatically record the vapor temperature and total volume percent recovered at the time the distillation is discontinued.

A9.6.11 Upon completion of the distillation, the apparatus will automatically enter into a cooling cycle. After the temperature drops below a safe limit, usually 100°C, the pressure in the distillation assembly is gradually increased to atmospheric pressure. The flask and receiver can then be removed for cleaning. If it is necessary to dismantle the apparatus before the contents have cooled below 100°C, use dry nitrogen to bring the system pressure back to atmospheric pressure.

A9.6.12 The unit is cleaned as described in 10.13.

A9.6.13 Any material in the cold trap is recovered as described in 10.12.

A9.7 Precision and Bias:

A9.7.1 The precision of the test method using automatic Test Method D 1160 equipment is being determined.

A9.7.2 The bias between the manual and the automatic test method is being determined.



APPENDIX

(Nonmandatory Information)

X1. VAPOR TEMPERATURE MEASURING DEVICE ALIGNMENT PROCEDURE

X1.1 A tool to help in determining the spillover point was made out of an approximately 3 mm rod approximately 300 mm in length. A 90° bend was made approximately 25 mm from one end. Then a 2 mm inside diameter (ID) flexible plastic tubing was placed over the end to a total distance of about 30 mm. The flexible plastic tubing is used to prevent scratching of the glassware. The length of the bend is dependent upon the ID of the distillation column.

X1.2 This tool is then carefully moved up from the bottom of the distillation column until the end can protrude into the condensing arm. The tip of the bent end of the tool should then be rested on the highest point of the lower internal junction of the distillation column and the condensing section of the vacuum-jacketed column assembly. This is the spillover point. Then with a ballpoint pen make a mark on one side of the outside glass of the distillation column in line with the bottom of the tool. Repeat this step on the opposite side of the distillation column. With two straight edge rulers confirm that the distance from the top of the distillation column down to each of the two marks is equal. If they are both equal, then this is the spillover point. If they are not equal, repeat the steps described above.

X1.3 Once the spillover point has been determined, then make a mark on both sides of the outside glass 3 mm ± 1 mm below the marks determined above. This is where the *top of the sensing tip* should be aligned. (If possible, these two sets of marks should be permanently made on the distillation column since they should not change unless repairs are made to the glassware).

X1.4 While holding the distillation column such that you can see through the distillation column, insert the thermocouple which has been placed in the tapered screw cap down into the distillation column. With the tapered fitting in its normal operating position adjust the thermocouple (up or down) so that the *top of the sensing tip* is aligned with the lower of the two marks made on the outside glass. Once in the proper position tighten the screw cap. Then mark the point where the thermocouple aligns with the top of the screw cap with a permanent marker. This marking will be accurate for this particular distillation column, tapered screw cap, and thermocouple only and can be used to verify proper alignment.

SUMMARY OF CHANGES

Subcommittee D02.08 has identified the location of selected changes to this standard since the last issue (D 1160-99) that may impact the use of this standard.

- (1) Replaced old vacuum-jacketed column figure with a new Fig. 4. (2) Created a new Table 1.

ASTM International takes no position respecting the validity of any patent rights asserted in connection with any item mentioned in this standard. Users of this standard are expressly advised that determination of the validity of any such patent rights, and the risk of infringement of such rights, are entirely their own responsibility.

This standard is subject to revision at any time by the responsible technical committee and must be reviewed every five years and if not revised, either reapproved or withdrawn. Your comments are invited either for revision of this standard or for additional standards and should be addressed to ASTM International Headquarters. Your comments will receive careful consideration at a meeting of the responsible technical committee, which you may attend. If you feel that your comments have not received a fair hearing you should make your views known to the ASTM Committee on Standards, at the address shown below.

This standard is copyrighted by ASTM International, 100 Barr Harbor Drive, PO Box C700, West Conshohocken, PA 19428-2959, United States. Individual reprints (single or multiple copies) of this standard may be obtained by contacting ASTM at the above address or at 610-832-9585 (phone), 610-832-9555 (fax), or service@astm.org (e-mail); or through the ASTM website (www.astm.org).