

This document is not an ASTM standard and is intended only to provide the user of an ASTM standard an indication of what changes have been made to the previous version. Because it may not be technically possible to adequately depict all changes accurately, ASTM recommends that users consult prior editions as appropriate. In all cases only the current version of the standard as published by ASTM is to be considered the official document.



Designation: D 1478 – 91 (Reapproved 1997)

Designation: D 1478 – 02

An American National Standard

Standard Test Method for Low-Temperature Torque of Ball Bearing Grease¹

This standard is issued under the fixed designation D 1478; the number immediately following the designation indicates the year of original adoption or, in the case of revision, the year of last revision. A number in parentheses indicates the year of last reapproval. A superscript epsilon (ϵ) indicates an editorial change since the last revision or reapproval.

This standard has been approved for use by agencies of the Department of Defense.

¹ This test method is under the jurisdiction of ASTM Committee D02 on Petroleum Products and Lubricants and is the direct responsibility of Subcommittee D02.G0 on Lubricating Grease.

Current edition approved Sept. 15, 1991; Nov. 10, 2002. Published November 1991; February 2003. Originally published as D 1478 – 57 T, approved in 1957. Last previous edition D 1478 – 85, approved in 1997 as D 1478–91(1997).

1. Scope *

1.1 This test method covers the determination of the extent to which a grease retards the rotation of a slow-speed ball bearing by measuring starting and running torques at low temperatures (below -20°C (0°F)).

1.1.1 Torque measurements are limited by the capacity of the torque-measuring equipment.

NOTE 1—When initially developed, the original dynamometer scale limited the torque capacity to approximately 30 000 g-cm; the original dynamometer scale is obsolete, however. The suggested replacement scale has not been evaluated; it could extend the limit to approximately 75 000 g-cm.

1.2 The values stated in SI units are to be regarded as the standard in this test method, except for torque values which are given in cgs-metric units, which are universally used in grease specifications. Other units are provided for information only.

1.3 *This standard does not purport to address all of the safety concerns, if any, associated with its use. It is the responsibility of the user of this standard to establish appropriate safety and health practices and determine the applicability of regulatory limitations prior to use.* For specific hazard and warning statements, see Note 2, Note 4, Note 5, Note 6, 6.1.1, 7.2, 7.4, 8.7, and Note 8, 8.11.

2. Referenced Documents

2.1 *ASTM Standards:*

D 235 Specification for Mineral Spirits (Petroleum Spirits) (Hydrocarbon Drycleaning Solvents)²

D 4693 Test Method for Low-Temperature Torque of Grease-Lubricated Wheel Bearings²

² Annual Book of ASTM Standards, Vol 06.04, 05.02.

~~Test Methods for Rating Motor, Diesel, and Aviation Fuels; Motor Fuels (Section I), Reference Materials and Blending Accessories (Annex 2), Reference Materials (A2.7), and Table 32; (Specification for ASTM Knock Test Reference Fuel, n-heptane)³~~

2.2 *ANSI/AFBMA Standard:*

~~Standard 20-1987 Radial Bearings of Ball, Cylindrical, Roller, and Spherical-Roller Type—Metric Designs (AFBMA Code 20BCO2JO)⁴~~

2.3 *ASTM Adjuncts:*

~~Standard ball bearings (set of 5 ball bearings)³~~

Annual Book of

³ The ball bearing has been standardized by Subcommittee D02.G0. Available from ASTM Standards, Vol 05.04: International Headquarters. Order Adjunct No. ADJD3336.

Annual Book of ASTM Standards, Vol 05.02:

⁴ Available from AFBMA (Anti-Friction Bearing Manufacturers' Association), 1101 Connecticut Avenue, N.W., Suite 700, Washington, DC 20036-4303.

3. Terminology

3.1 Definitions of Terms Specific to This Standard:

3.1.1 *low-temperature torque, n*—the torque in g·cm required to restrain the outer ring of a No. 6204 size open ball bearing lubricated with the test grease while the inner ring is rotated at 1 ± 0.05 r/min at the test temperature.

3.1.2 *running torque, n*—the 15-s average value of the torque after rotation for a specified period of time (60 min).

3.1.3 *starting torque, n*—the maximum torque measured at the start of rotation.

4. Summary of Test Method

4.1 A No. 6204 open ball bearing is packed completely full of the test grease and cleaned off flush with the sides. The bearing remains stationary while ambient temperature is lowered to the test temperature and held there for 2 h. At the end of this time, the inner ring of the ball bearing is rotated at 1 ± 0.05 r/min while the restraining force on the outer ring is measured.

4.2 Torque is determined by multiplying the restraining force by the radius of the bearing housing. Both starting torque and torque after 60 min of rotation (running torque) are determined.

5. Significance and Use

5.1 This test method was developed using greases having very low torque characteristics at -54°C (-65°F). Specifications for greases of this type commonly require testing at this temperature. Specifications for greases of other types can require testing at temperatures from -75 to -20°C (-100 to 0°F).

5.2 This test method has proved helpful in the selection of greases for low-powered mechanisms, such as instrument bearings used in aerospace applications. The suitability of this test method for other applications requiring different greases, speeds, and temperatures should be determined on an individual basis.

5.3 Test Method D 4693 may be better suited for applications using larger bearings or greater loads. However, greases having such characteristics that permit torque evaluations by either this test method or Test Method D 4693 will not give the same values in the two test methods (even when converted to the same torque units) because the apparatus and test bearings are different.

6. Apparatus⁵

6.1 Fig. 1 shows a suitable torque test apparatus assembly.

It consists of the components described in 6.1.1-6.1.5.

6.1.1 *Low-Temperature Box*—Any well-insulated box of at least 0.03 m^3 (1 ft^3) interior volume, in which the air temperature can be controlled and maintained within 0.5°C (1°F) of the test temperature.

NOTE 2—Caution: Direct temperature. (Warning—Direct impact on the test bearing by an air stream colder than the test temperature must be avoided to preclude erroneous results. Baffles should be used where necessary to prevent such direct impact. The drive mechanism can be mounted externally as shown in Fig. 2, or the entire drive mechanism can be inserted directly into the box. When the drive is mounted externally, the temperature measured at a point on the surface of the test shaft between the test bearing and wall of the box shall be not more than 0.5°C (1°F) above the test temperature.)

6.1.2 *Drive Assembly*, as shown in Fig. 2, including drive motor, gear reductor, and test shaft. The test shaft shall receive the test bearing against a shoulder having a diameter smaller than the inner race shoulder of the bearing. Use a spacer washer of the same diameter and at least 1.6 mm ($1/16$ in.) thick, along with a test bearing lock nut, to clamp the inner ring of the test bearing to the 1 r/min shaft.

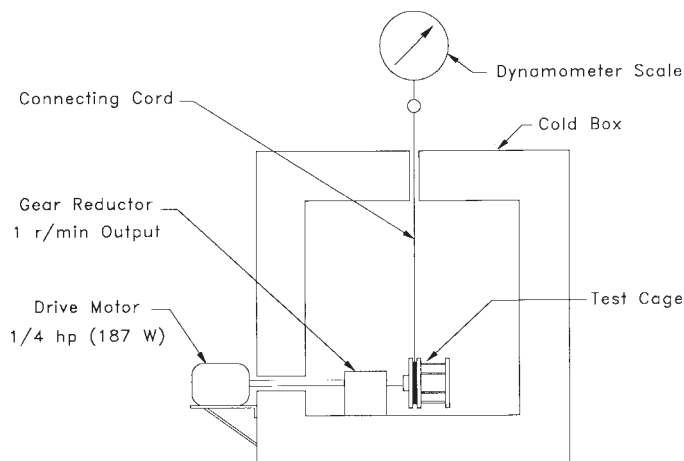

FIG. 1 Torque Test Apparatus Assembly

⁵ Low Temperature Torque Apparatus available from AFBMA (Anti-Friction Bearing Manufacturers' Association), 1101 Connecticut Avenue, N.W., Suite 700, Washington, DC 20036-4303. Koehler Instrument Company, 1595 Sycamore Ave., Bohemia, NY 11716.

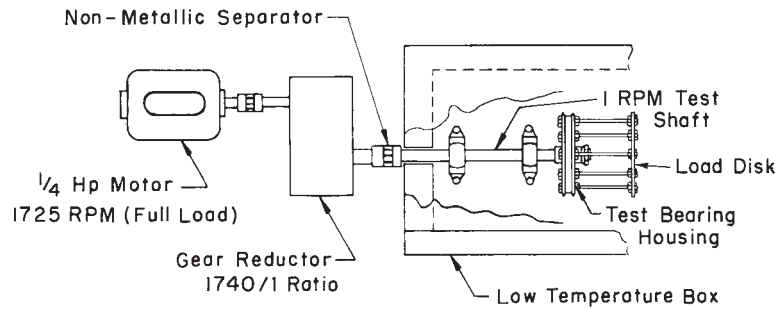

FIG. 2 Drive (Top View)

6.1.3 *Housing (Cage)*—Bearing housing, load disk, load ring, clamp rod, and associated parts made in accordance with Fig. 3. Adjust the housing mass of Part 2A (load disk) to be 454 ± 3 g (1 lb). Alternatively, if Part 2B (load ring) is used, adjust the mass of Part 2B to be 454 ± 3 g (1 lb).

6.1.4 *Torque-Measuring Equipment*—A calibrated dynamometer scale⁶ having a range of approximately 0 to 10 kg, 0 to 100 N, or 0 to 25 lb, with a large face diameter (approximately 200 mm (8 in.), or larger) and a suitable connecting cord.⁷

⁶Low Temperature Torque Apparatus

⁶Dynamometer Scale, QDS-25, available from Koehler Instrument Company, 1595 Sycamore Ave., Bohemia, R. Chatillon & Sons Inc., 83-28 Kew Gardens Rd., Kew Gardens, NY-H746-11415.

⁷Dynamometer Scale, QDS-25, available from R. Chatillon & Sons Inc., 83-28 Kew Gardens Rd., Kew Gardens, NY 11415.

⁷Any suitable cord of sufficient length is acceptable. Braided metallic cable, such as Minneapolis-Honeywell Drive Cable No. 77050-1, fitted with a ring or loop on each end, is recommended. A15-kg (35-lb) test string saturated with silicone oil also has been found satisfactory.

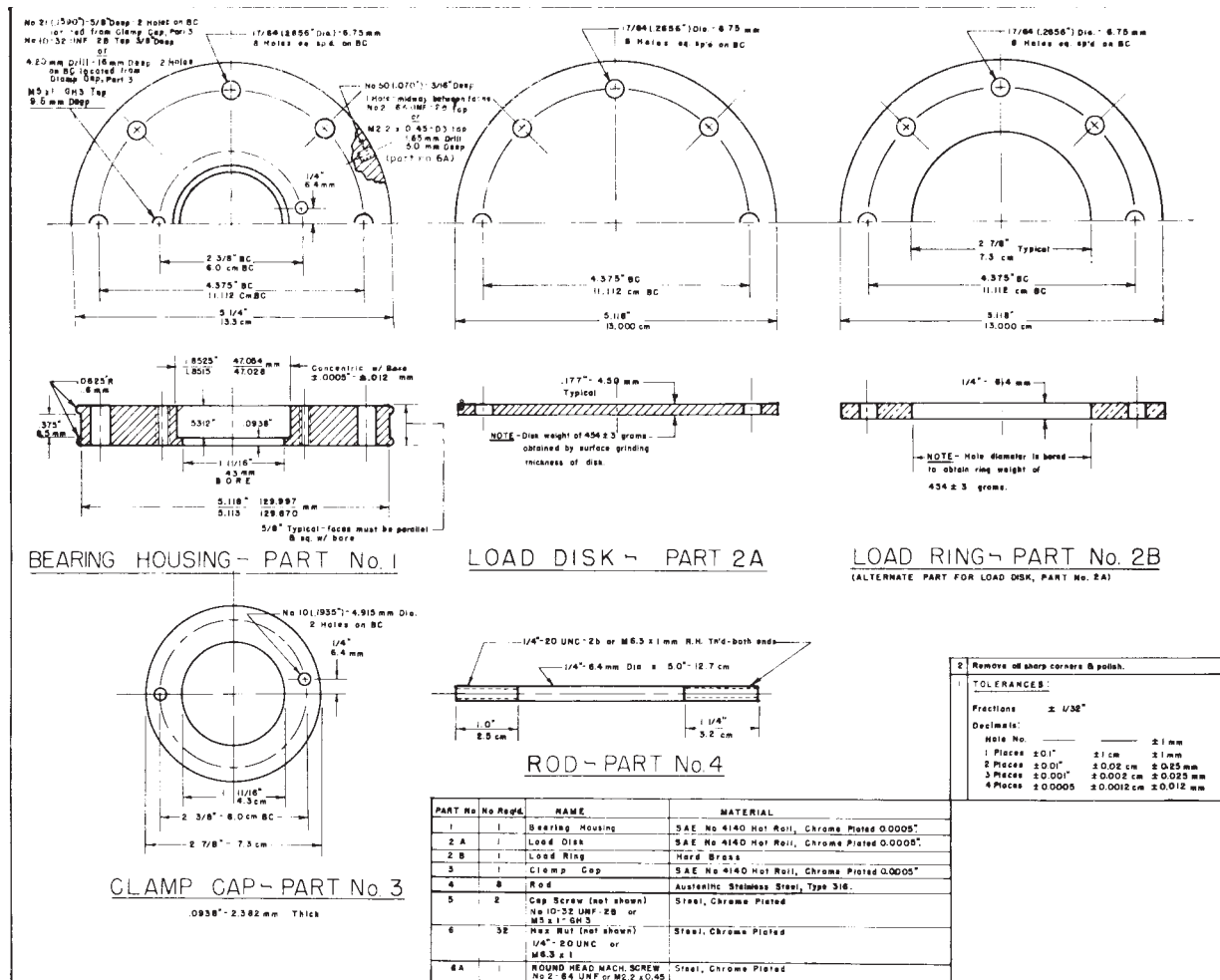

FIG. 3 Cage Parts

NOTE 32—Substitution of other suitable torque-measuring equipment, such as a strain-gage load cell, is permitted.

6.1.5 *Spindle and Grease Cup*, as shown in Fig. 4 and Fig. 5, respectively.

7. Materials

7.1 *Test Bearing*—No. 6204 size open ball bearing (Standard 20-1987, AFBMA Code 20BCO2JO) containing eight 7.9 mm (5/16 in.) balls, separated by a two-piece, pressed steel cage, and manufactured to ABEC-3 (Annular Bearing Engineering Committee) tolerances with the standard radial clearance of 0.021 to 0.028 mm (0.0008 to 0.0011 in.).^{8,4}

7.2 *Stoddard Solvent*, conforming to Specification D 235, Type I.

NOTE 4—**Warning:** Combustible; (also known as Mineral Spirits or White Spirits), Reagent Grade. (**Warning**—Combustible, Health Hazard.)

7.3 *Purity of Reagents*—Reagent grade chemicals shall be used in all tests. Unless otherwise indicated, it is intended that all reagents shall conform to the specifications of the committee on Analytical Reagents of the American Chemical Society, where such specifications are available.⁹

7.4 *n-Heptane*, commercial reagent grade or ASTM Knock Test Reference Fuel, n-heptane.

NOTE 5—**Warning:** Flammable; minimum purity. (**Warning**—Flammable, Health Hazard.)

8. Procedure

8.1 Wash the selected test bearing thoroughly in Stoddard solvent and rinse it in a beaker of n-heptane. Dry the bearing for approximately 20 min in a warm oven (not over 100°C (212°F)). Permit the bearing to cool to room temperature before proceeding.

8.2 Lubricate the bearing with five drops of oil having a viscosity of 28 to 32 cSt at 100°C (135 to 150 SUS at 210°F). The bearing shall then show no roughness or catching when rotated between the fingers while applying light pressure axially and then

⁸ Any suitable cord

⁸ Supporting data (copies of sufficient length is acceptable. Braided metallic cable, such as Minneapolis-Honeywell Drive Cable No. 77050-1, fitted with a ring or loop on each end, is recommended. A 15 kg (35-lb) correspondence and test string saturated with silicone oil also has data regarding the selection of the test bearing) have been filed at ASTM International Headquarters and may be obtained by requesting Research Report RR: D02-1272.

⁹ The ball bearing has been standardized

⁹ Reagent Chemicals, American Chemical Society Specifications, American Chemical Society, Washington, DC. For Suggestions on the testing of reagents not listed by Subcommittee D02.G and is available from ASTM Headquarters the American Chemical Society, see *Annual Standards for a nominal cost by specifying ADJ03336. Copies of correspondence Laboratory Chemicals*, BDH Ltd., Poole, Dorset, U.K., and test data regarding the selection of the test bearing can be obtained from the Information Center at ASTM Headquarters by requesting Research Report RR:D02-1272; *United States Pharmacopeia and National Formulary*, U.S. Pharmacopeial Convention, Inc. (USPC), Rockville, MD.

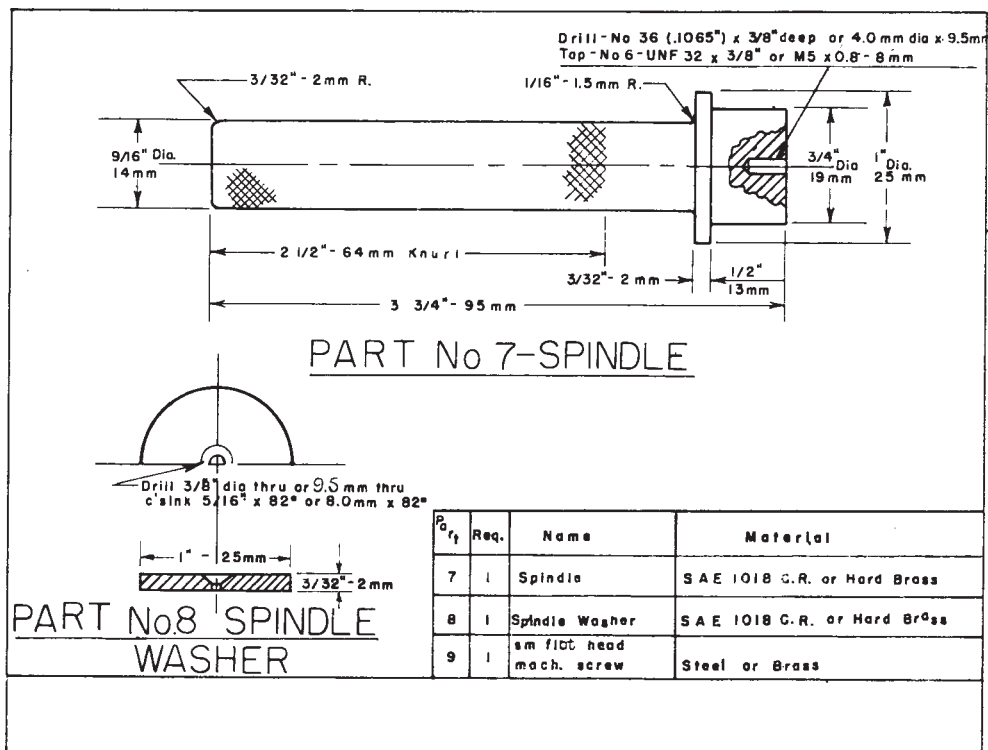

FIG. 4 Spindle

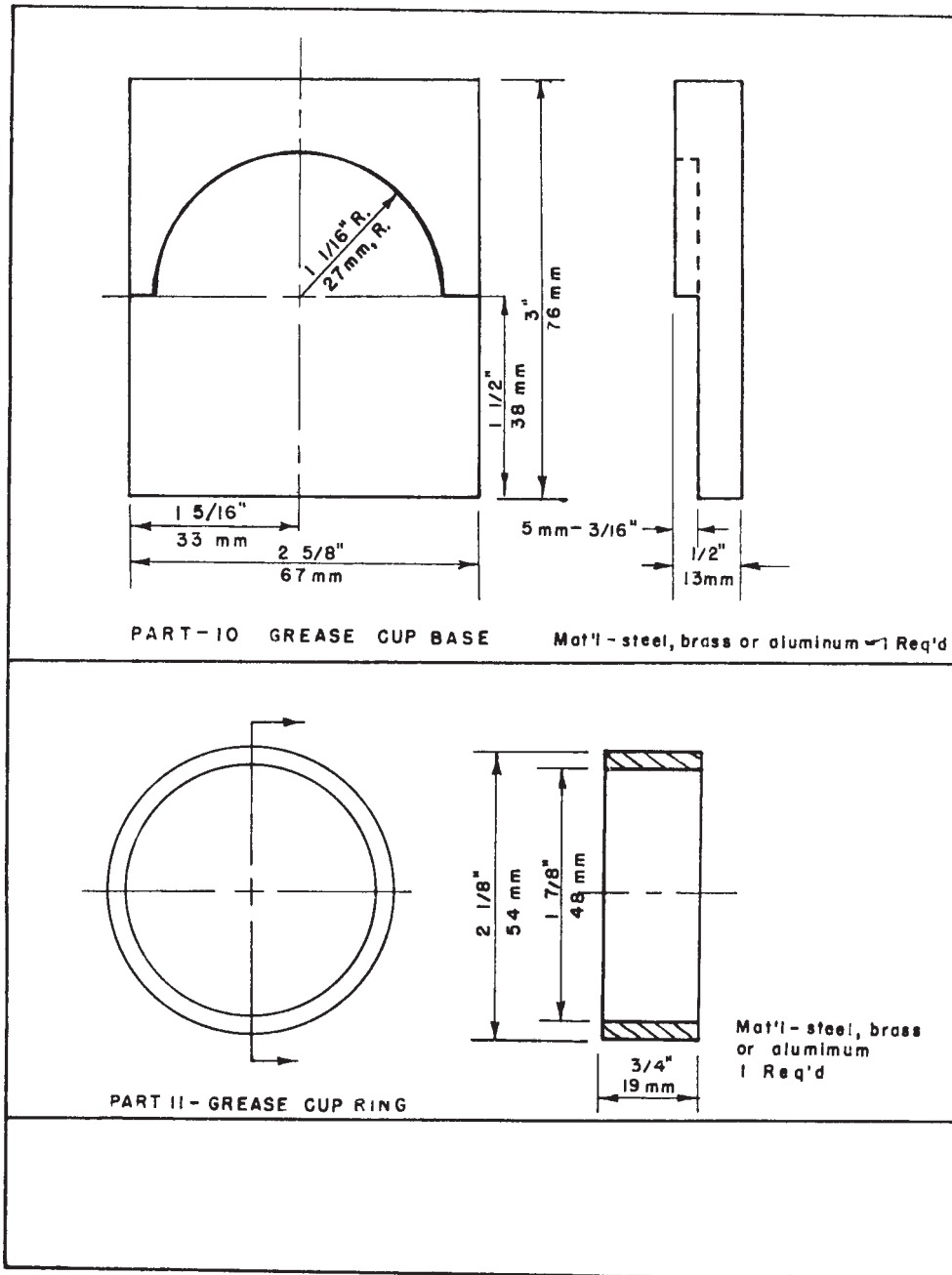

FIG. 5 Grease Cup

radially. Use the dynamometer to determine the running torque at room temperature; note the average and maximum running torque peaks. The average shall not exceed 20 g-cm (2.0 mN-m), and no peak shall exceed 25 g-cm (2.5 mN-m). If torque values fall below these limits, the bearing is suitable for the grease torque test. If torque values exceed these limits, the bearing should be recleaned and retested or discarded.

8.3 Clean and dry a bearing that has been determined to be acceptable (8.2). Mount the bearing on a hand spindle (Fig. 4), fastening the inner race by means of the washer and screw. Fill the grease cup (Fig. 5) at least three-fourths full of the test grease, using a clean steel spatula. Minimize the inclusion of air.

8.4 Force the bearing down into the grease and rotate the spindle-bearing assembly slowly, first in one direction and then the other, to ensure that grease is worked into all parts of the bearing. When the bearing bottoms in the cup, slide the cylindrical cup ring off the plate and remove the spindle-bearing assembly from the cup. (The assembly may be pushed or pulled through the cup.)

8.5 Remove the bearing from the spindle. Turn the bearing end-for-end, and refasten it on the spindle.

8.6 Repack excess grease into the assembled grease cup. Again, force the bearing down into the grease, while rotating the spindle-bearing assembly slowly, first in one direction and then the other, until the bearing bottoms.

8.7 Slide the cup ring off of the plate, and remove the spindle-bearing assembly from the cup ring. Scrape the excess grease

off flush with the sides of the bearing, filling any visible voids, and then remove the ~~spindle~~.

~~NOTE 6—~~**Caution:** Take ~~spindle~~. (**Warning—**Take care not to rotate the bearing at any time after striking the grease flush and prior to the measurement of starting torque.)

8.8 Insert the packed bearing into the test housing and fasten the clamp cap over the bearing.

8.9 With the low-temperature box precooled to the test temperature, open the box and slide the test bearing and housing over the end of the test shaft. Fasten it with the washer and nut tightly enough to prevent slippage.

8.10 Attach the cord under the head of the screw on the periphery of the housing. Rotate the test shaft until the slack in the cord hanging from the hook on the dynamometer scale above is almost taken up. The screw on the periphery must then be at least 90 degrees down from vertical. More than 90 degrees is acceptable, provided that the cord does not slip off the periphery of the housing (Fig. 1).

~~NOTE 73—~~Measurements can also be made from horizontal or other positions if the cord attaching point is at or beyond the point of tangency of the cord while torque is being measured. This will ensure a full 65-mm (2.56-in.) torque radius.

8.11 Close the box, and recool it to the test temperature. Maintain this temperature within $\pm 0.5^{\circ}\text{C}$ (1°F) for 2 h after the box has recovered to the test ~~temperature~~.

~~NOTE 8—~~**Caution:** During ~~temperature~~. (**Warning—**During this time the bearing must not be disturbed or the test will be invalid.)

8.11.1 It is desirable that excessive condensation of moisture from the air in the cold box be prevented, especially during humid weather. To this end and prior to the test, place shallow trays containing a desiccant in the bottom of the low temperature box.

8.12 Check the torque cord to be sure it is free of ice and not stuck to the box. A split rubber stopper can be used to close the hole in the box wall, through which the cord runs, to keep the cord and passage free of ice from moisture-laden air. Remove the stopper before the run.

8.13 To determine starting torque, start the drive motor and observe the dynamometer scale. Record the maximum reading and calculate the starting torque according to Section 9.

8.14 Continue rotation of the test shaft for 60 min while maintaining the test temperature within $\pm 0.5^{\circ}\text{C}$ (1°F). At the end of this time, observe the dynamometer reading for a period of 15 s, and record the average value and calculate the running torque according to Section 9.

8.15 When running repeat tests, the bearing shall be recleaned (see 8.1) and packed with a fresh charge of grease (see 8.3 and 8.4) between tests. Do not force out tested grease with a fresh charge of grease.

~~NOTE 94—~~A pressure sprayer employing Stoddard Solvent can be used to facilitate the removal of grease from the bearing.

9. Calculation and Report

9.1 Depending on the dynamometer scale calibration, calculate and report starting and running torques in g-cm to three significant figures using the appropriate equation, as follows:

9.1.1 For a scale calibrated in grams:

$$\text{torque} = 6.50 \times \text{scale reading} \quad (1)$$

9.1.2 For a scale calibrated in pounds:

$$\text{torque} = 2950 \times \text{scale reading} \quad (2)$$

9.1.3 For a scale calibrated in Newtons:

$$\text{torque} = 663 \times \text{scale reading} \quad (3)$$

9.2 To convert torque in g-cm to torque in mN-m, multiply by 0.0981 and round to three significant figures.

10. Precision and Bias ¹⁰

10.1 *Precision*—The precision of this test method was not obtained in accordance with currently accepted guidelines (for example, Committee ~~D-2~~ D02 Research Report RR: D02-1007, Manual on Determining Precision Data for ASTM Methods on Petroleum Products and Lubricants).¹⁰

10.1.1 *Alternative A:*

10.1.1.1 Low-temperature torque results derived from cooperative testing using this procedure show appreciable scatter. In general, the data were found to conform to Weibull probability distributions, rather than the “normal” distributions around which ASTM statements of repeatability and reproducibility are formulated. Weibull parameters such as Slope, L10, and L50 have been used to describe the test data.

10.1.1.2 Precision may be judged from Fig. 6 and Fig. 7, Weibull plots for starting and running torques, respectively, and from the calculated Weibull parameters in Table 1. Precision may also be judged from the range for the center 50 % of the reported test results.

¹⁰ There is no research report on file because this test method was developed before research report guidelines were instituted, and data are no longer available.

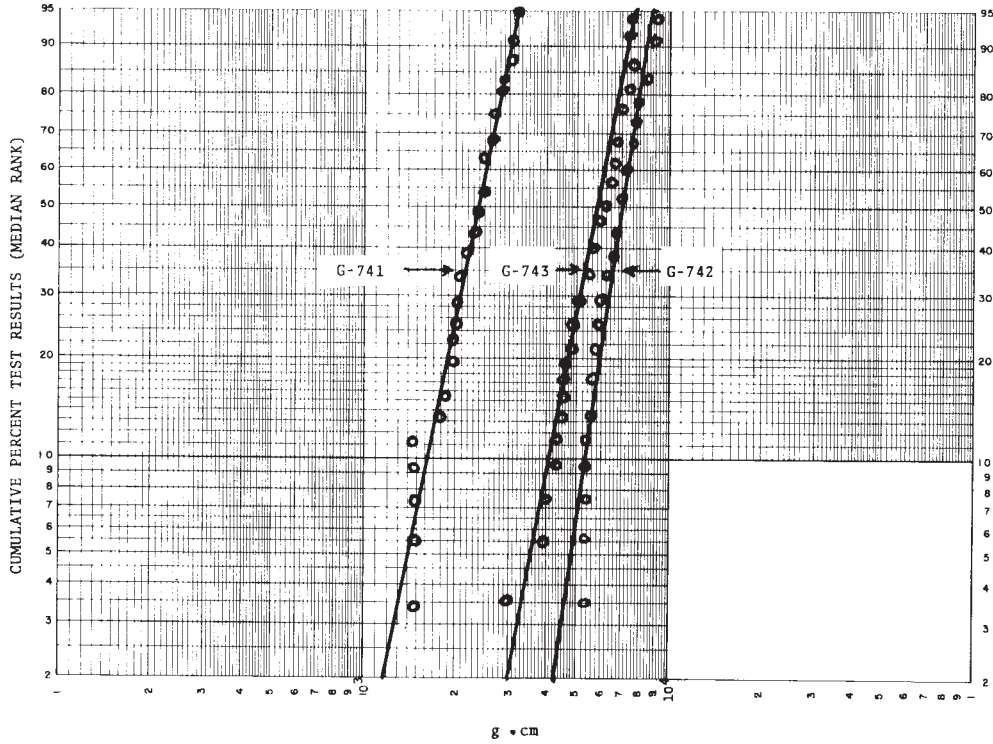

FIG. 6 Weibull Plot Starting Torque

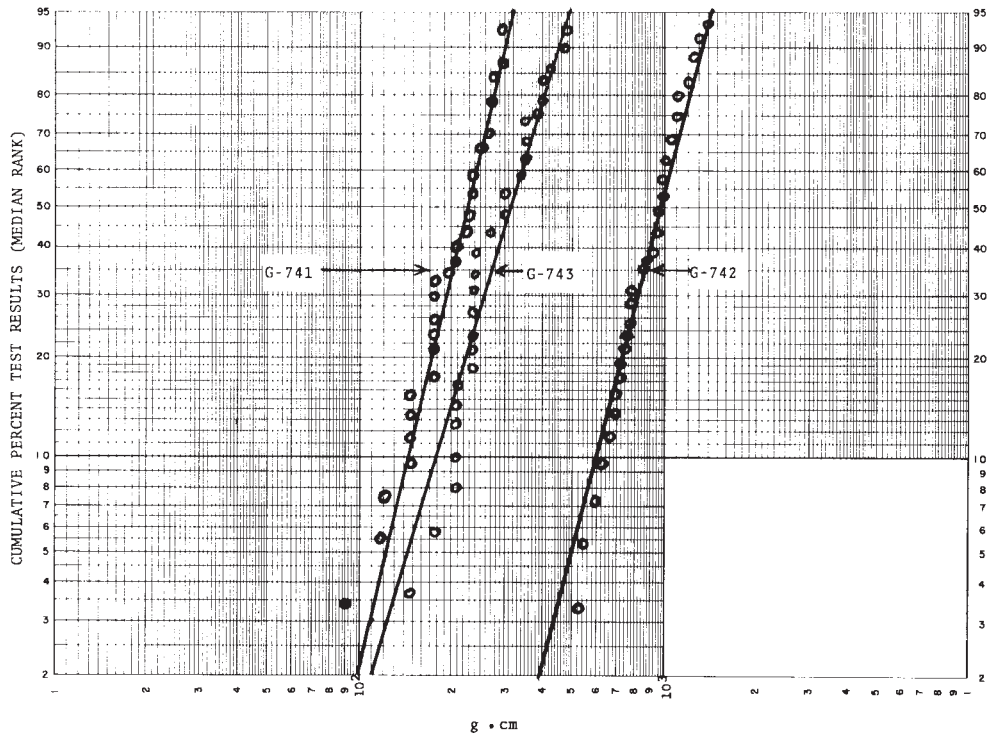

FIG. 7 Weibull Plot Running Torque

10.1.1.3 Replicate testing is essential when using this procedure, since appreciable scatter in test results can be expected.

10.1.2 *Alternative B:*

10.1.2.1 The following criteria should be used in judging the acceptability of results (95 % confidence). These calculations are based on logarithmic data transformations.

10.1.2.2 *Repeatability*—Duplicate results by the same operator should be considered suspect if they differ by more than the following amounts:

TABLE 1 Weibull Parameters

	Starting Torque			Torque After 60 min Running		
	G-741	G-742	G-743	G-741	G-742	G-743
Weibull Slope	4.98	6.10	5.15	4.23	3.93	3.26
90 % confidence limits	4.03 to 5.84	4.91 to 7.18	4.16 to 6.05	3.42 to 4.97	3.75 to 5.43	2.61 to 3.85
L_{10} Level, g·cm	1638	5157	4154	143	594	176
90 % confidence limits	1412 to 1792	4569 to 5549	3597 to 4532	120 to 159	492 to 666	140 to 202
L_{50} Level, g·cm	2391	7022	5988	223	960	315
90 % confidence limits	2255 to 2446	6699 to 7331	5659 to 6305	208 to 242	892 to 1027	288 to 342
Range for center	2006 to 2655	5950 to 7670	4838 to 6785	177 to 266	767 to 1105	236 to 390
50 % of results, g·cm						
<i>SI equivalents:</i>						
L_{10} Level, mN·m	161	506	408	14.0	58.3	17.3
90 % confidence limits	139 to 176	448 to 544	353 to 445	11.8 to 15.6	48.3 to 65.3	13.7 to 19.8
L_{50} Level, mN·m	235	689	587	22.0	94.2	30.9
90 % confidence limits	221 to 240	657 to 719	555 to 619	20.4 to 23.7	87.5 to 101	28.3 to 33.6
Range for center	197 to 260	584 to 752	475 to 666	17.4 to 26.1	75.2 to 108	23.2 to 38.3
50 % of results, mN·m						

Starting torque	34 % of their mean
Torque after 60 min	78 % of their mean

10.1.2.3 *Reproducibility*—The results submitted by each of two laboratories should be considered suspect if they differ by more than the following amounts:

Starting torque	79 % of their mean
Torque after 60 min	132 % of their mean

10.2 *Bias*—Bias cannot be determined in this test method because the value of the torque can be defined only in terms of the test method.

11. Keywords

11.1 ball bearing grease; ball bearing torque; low-temperature torque; lubricating grease; torque

SUMMARY OF CHANGES

Committee D02.G0 has identified the location of selected changes to this standard since the last issue (D 1478-91 (1997)) that may impact the use of this standard.

- (1) Reworded 6.1.3 to clarify that the housing mass is referring to the load disk or ring.
- (2) Changed required quality of Stoddard solvent in 7.2 from “conforming to D 235 specifications” to “reagent grade.” Deleted associated reference and footnote.
- (3) Changed required quality of n-Heptane in 7.4 (formerly 7.3). Deleted associated footnote.
- (4) Moved warnings from notes to section text throughout.

ASTM International takes no position respecting the validity of any patent rights asserted in connection with any item mentioned in this standard. Users of this standard are expressly advised that determination of the validity of any such patent rights, and the risk of infringement of such rights, are entirely their own responsibility.

This standard is subject to revision at any time by the responsible technical committee and must be reviewed every five years and if not revised, either reapproved or withdrawn. Your comments are invited either for revision of this standard or for additional standards and should be addressed to ASTM International Headquarters. Your comments will receive careful consideration at a meeting of the responsible technical committee, which you may attend. If you feel that your comments have not received a fair hearing you should make your views known to the ASTM Committee on Standards, at the address shown below.

This standard is copyrighted by ASTM International, 100 Barr Harbor Drive, PO Box C700, West Conshohocken, PA 19428-2959, United States. Individual reprints (single or multiple copies) of this standard may be obtained by contacting ASTM at the above address or at 610-832-9585 (phone), 610-832-9555 (fax), or service@astm.org (e-mail); or through the ASTM website (www.astm.org).