



Standard Test Method for Characteristic Groups in Rubber Extender and Processing Oils and Other Petroleum-Derived Oils by the Clay-Gel Absorption Chromatographic Method¹

This standard is issued under the fixed designation D 2007; the number immediately following the designation indicates the year of original adoption or, in the case of revision, the year of last revision. A number in parentheses indicates the year of last reapproval. A superscript epsilon (ϵ) indicates an editorial change since the last revision or reapproval.

1. Scope

1.1 This test method covers a procedure for classifying oil samples of initial boiling point of at least 260°C (500°F) into the hydrocarbon types of polar compounds, aromatics and saturates, and recovery of representative fractions of these types. This classification is used for specification purposes in rubber extender and processing oils.

NOTE 1—See Test Method D 2226.

1.2 This test method is not directly applicable to oils of greater than 0.1 mass % pentane insolubles. Such oils can be analyzed after removal of these materials, but precision is degraded (See Appendix X1).

1.3 The values stated in SI units are to be regarded as the standard. The values given in parentheses are for information only.

1.4 *This standard does not purport to address all of the safety concerns, if any, associated with its use. It is the responsibility of the user of this standard to establish appropriate safety and health practices and determine the applicability of regulatory limitations prior to use.* Specific precaution statements are given in 6.1, Section 7, A1.4.1, and A1.5.5.

2. Referenced Documents

2.1 ASTM Standards:

D 86 Test Method for Distillation of Petroleum Products at Atmospheric Pressure²

D 323 Test Method for Vapor Pressure of Petroleum Products (Reid Method)²

D 1159 Test Method for Bromine Number of Petroleum Distillates and Commercial Aliphatic Olefins by Electro-metric Titration²

D 2226 Classification for Various Types of Petroleum Oils for Rubber Compounding Use³

¹ This test method is under the jurisdiction of ASTM Committee D02 on Petroleum Products and Lubricants and is the direct responsibility of Subcommittee D02.04 on Hydrocarbon Analysis.

Current edition approved Nov. 10, 2001. Published January 2002. Originally published as D 2007 – 68T. Last previous edition D 2007 – 01.

² *Annual Book of ASTM Standards*, Vol 05.01.

³ *Annual Book of ASTM Standards*, Vol 09.01.

D 5309 Specification for Cyclohexane 999⁴

E 691 Practice for Conducting an Interlaboratory Study to Determine the Precision of a Test Method⁵

3. Terminology

3.1 Definitions of Terms Specific to This Standard:

3.1.1 The following terms refer to the hydrocarbon types and structural groups as measured by this test method:

3.1.1.1 *asphaltenes*, or *n-pentane insolubles*—insoluble matter that precipitates from a solution of oil in *n-pentane* under the specified conditions.

3.1.1.2 *polar compounds*—material retained on adsorbent clay after percolation of the sample in *n-pentane* eluent under the conditions specified.

3.1.1.3 *polar aromatics*—synonym for polar compounds.

3.1.1.4 *aromatics*—material that, on percolation, passes through a column of adsorbent clay in a *n-pentane* eluent but adsorbs on silica gel under the conditions specified.

3.1.1.5 *saturates*—material that, on percolation in a *n-pentane* eluent, is not adsorbed on either the clay or silica gel under the conditions specified.

4. Summary of Test Method

4.1 The sample is diluted with solvent and charged to a glass percolation column containing clay in the upper section and silica gel plus clay in the lower section. *n-Pentane* is then charged to the double column until a definite quantity of effluent has been collected. The upper (clay) section is removed from the lower section and washed further with *n-pentane*. A toluene-acetone mixture 50 to 50 by volume is then charged to the clay section for desorption and a specified volume of effluent collected. The lower (gel) column may be desorbed by recirculation of toluene.

4.2 The solvents are completely removed from the recovered *n-pentane* and the toluene-acetone fractions and the residues are weighed and calculated as saturate and polar compounds contents. Aromatics may be calculated by difference, or measured following evaporation of the toluene used for desorption of the gel column.

⁴ *Annual Book of ASTM Standards*, Vol 06.04.

⁵ *Annual Book of ASTM Standards*, Vol 14.02.

4.3 When the sample contains more than 0.1 mass % of *n*-pentane insolubles, this test method cannot be used directly. The insoluble matter must be removed from the sample prior to charging to the column. A method for this removal is given as an appendix.

4.4 Alternative methods are provided (a) for recovery of aromatics from the gel column, and (b) for analysis of oil with high-polar content.

5. Significance and Use

5.1 The composition of the oil included in rubber compounds has a large effect on the characteristics and uses of the compounds. The determination of the saturates, aromatics, and polar compounds is a key analysis of this composition.

5.2 The determination of the saturates, aromatics, and polar compounds and further analysis of the fractions produced is often used as a research method to aid understanding of oil effects in rubber and other uses.

6. Apparatus

6.1 *Beakers, Anticreep*, 150-mL capacity, as illustrated in Fig. 1. (**Warning**—Beakers should be examined for sharp edges and fire polished, if necessary.)

6.2 *Clay-Gel Column*, constructed as illustrated in Fig. 2.

6.3 *Conical Flasks*, (Erlenmeyer), 250-mL capacity.

6.4 *Solvent Receiver*, capable of collecting solvent, without splashing or loss of material during the analysis. A wide-mouth, graduated, 500-mL capacity Erlenmeyer flask is one such example that has been found suitable to use.

6.5 *Filter Funnel*, long stem, 125-mm diameter; for use with 185 mm ready folded, fine-texture, rapid filter paper.

6.6 *Separatory Funnel*, 500 mL.

6.7 *Hot Plate*, explosion proof, controlled to a surface

temperature of 100 to 105°C.⁶

6.8 *Round Bottom Flask*, 3-necked, borosilicate, 500-mL capacity (Fig. 3).

6.9 *Condenser*, borosilicate (Fig. 3).

6.10 *Adapter Tube* with Vigreux column (Fig. 3).⁷

6.11 *Flexible Joint*, TFE-fluorocarbon and borosilicate, 24/40 T_S ground glass joints on each end.⁸

7. Reagents and Materials

7.1 *Purity of Reagents*, Reagent grade chemicals shall be used in all tests. Unless otherwise indicated, it is intended that all reagents shall conform to the specifications of the committee on Analytical Reagents of the American Chemical Society, where such specifications are available.⁹ Other grades may be used, provided it is first ascertained that the reagent is of sufficiently high purity to permit its use without lessening the accuracy of the determination.

7.2 *Acetone*, reagent grade, minimum purity. (**Warning**—Acetone is extremely flammable.)

7.3 *Calcium Chloride*, anhydrous granules.

7.4 *Clay Adsorbent*, 500 to 250 μm (30 to 60 mesh)

⁶ Temperatures should be uniform on the top of the hot plate. Some laboratory hot plates benefit by the inclusion of an aluminum plate, approximately 6-mm thick, included under or on top of regular plate top.

⁷ This item can be fabricated at any scientific glassblowing shop. It is also available from Owens Glass Apparatus, Inc., 128 River Road, Channelview, TX 77530.

⁸ Cole Parmer No. 6675-40 has been found suitable for this purpose.

⁹ *Reagent Chemicals, American Chemical Society Specifications*, American Chemical Society, Washington DC. For suggestions on the testing of reagents not listed by the American Chemical Society, see *Analar Standards for Laboratory Chemicals*, BDH Ltd., Poole, Dorset, U.K., and the *United States Pharmacopeia and National Formulary*, U.S. Pharmacopeial Convention, Inc. (USPC), Rockville, MD.

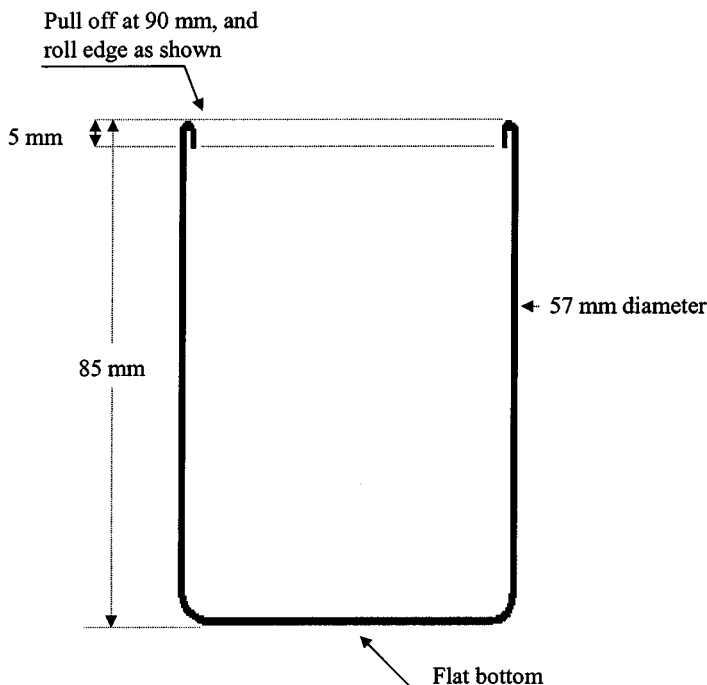
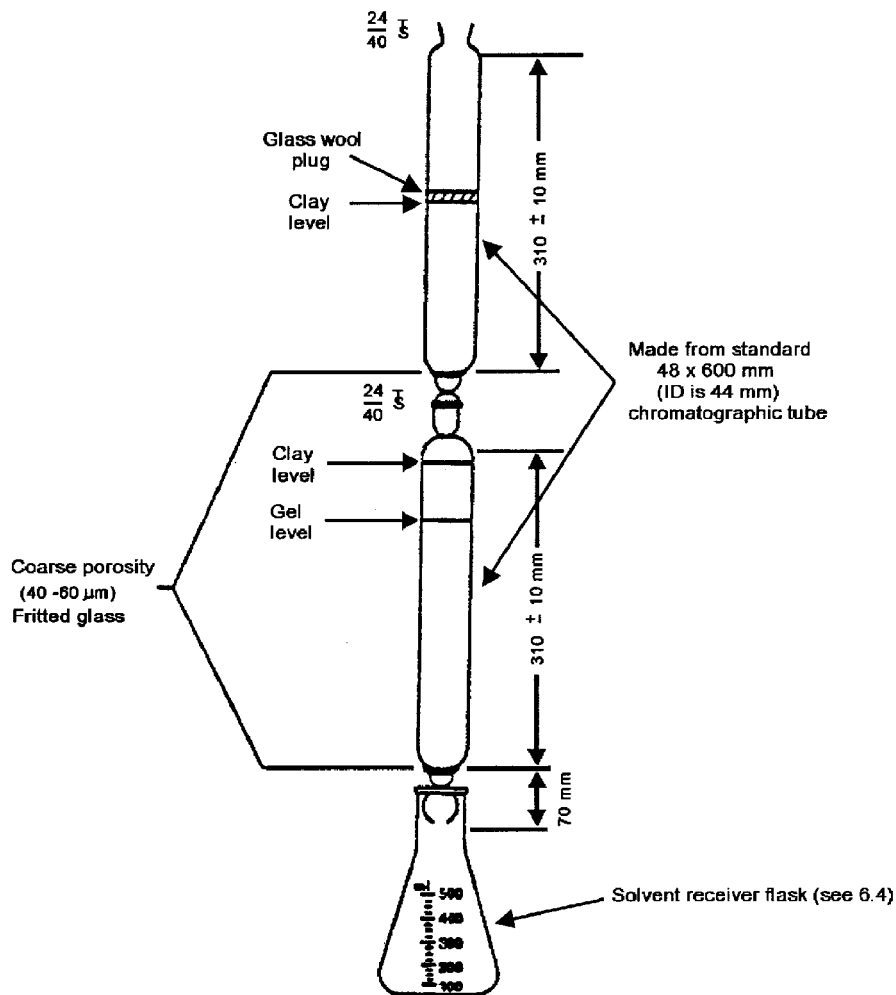

FIG. 1 Anticreep Beaker



NOTE 1—Check to ascertain ID is 44 mm.

FIG. 2 Clay-Gel Percolating Column

Attapulugus.¹⁰ Clay quality may be determined using the azobenzene equivalence test shown in Annex A1. The azobenzene activity test measures the adsorptive characteristics of the clay. Azobenzene equivalence value should be 30 to 35. Clay outside of these limits should be discarded.

7.5 *Cyclohexane*, conforming to Specification D 3055. (Optional, see 8.1.9.) (**Warning**—Cyclohexane is extremely flammable. Harmful if inhaled.)

7.6 *Pentane*,¹¹ reagent grade minimum purity: (**Warning**—*n*-Pentane is extremely flammable. Harmful if inhaled.)

Distillation (Test Method D 86).

Initial boiling point, min	33.4°C (92°F)
Dry point, max	40.5°C (105°F)

Reid vapor pressure (Test Method D 323), max 110 kPa (17 psi); Bromine number (Test Method D 1159), 0.5 maximum; Isopentane, maximum, 10 %; *n*-pentane, minimum, 80 %.

7.7 *Silica Gel*, activated, conforming to the following inspections:¹²

Sieve analysis	> 30 sieve size, 5 % (mass) maximum;
	> 50 sieve size, 45 % (mass) min
	> 100 sieve size, 80 % (mass) min
	> 200 sieve size, 94 % (mass) min

7.7.1 Gel should be activated for 4 h in an air oven at 190°C in a shallow pan.

7.8 *Toluene*, reagent grade minimum purity. (**Warning**—Toluene is flammable. Vapor harmful.)

7.9 *Toluene-Acetone Mixture* (50 to 50 by volume), mix equal volumes of toluene and acetone.

7.10 In order to obtain results that are consistent with those obtained elsewhere, it is very important that only the reagents and materials described in this section be used.

8. Procedure

8.1 Fractionation:

¹² Gel meeting these specifications is available from Forcoven Products, P.O. Box 1556, Humble, TX 77347-1556, packaged in 200 g moisture resistant packets. Sieve analysis should be checked on other sources of gel.

¹⁰ Available from Forcoven Products, P.O. Box 1556, Humble, TX 77347-1556. Packaged in moisture resistant twinned packets of 50 and 100 g (sufficient for one determination). These packets are packed 50 sets per case. It is important that extremes of temperature be avoided on stored clay samples.

¹¹ Available from Special Products Div., Phillips Petroleum Co., Bartlesville, OK.

ASTM D 2007

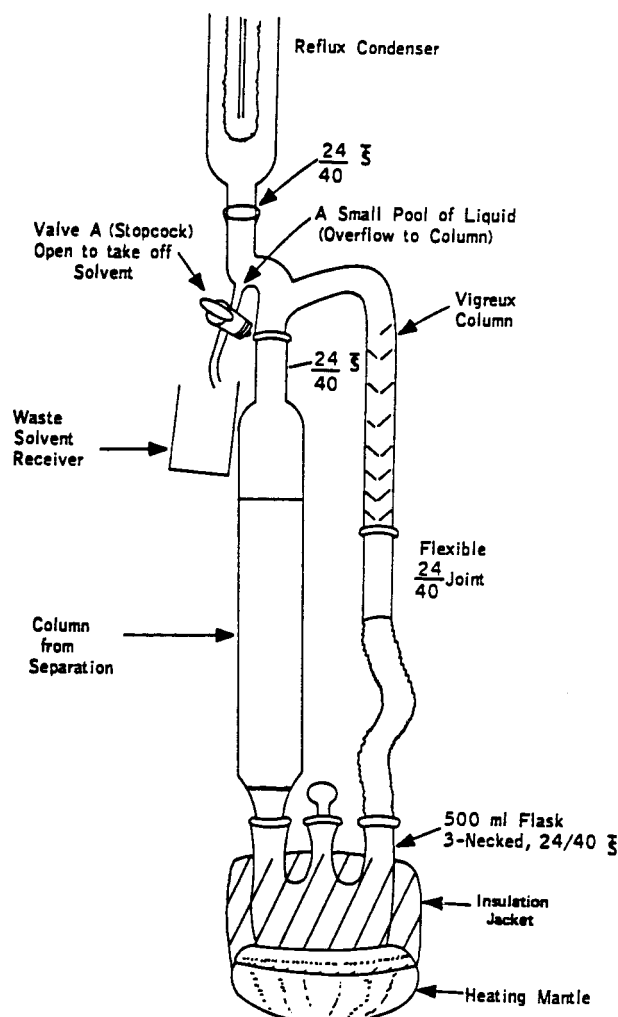

FIG. 3 Extraction Apparatus

8.1.1 Prepare the adsorption column (Fig. 2) by placing 100 g of clay adsorbent in the upper section of the column and 200 g of silica gel plus 50 g of clay on top of the gel in the lower section (Note 4). Place a piece of glass wool (of about 25-mm loose thickness) over the top surface of the clay in the upper column to prevent agitation of the clay while charging the eluent solvents. Join the columns (clay over gel) after lubricating the joint with hydrocarbon-insoluble grease. It is important that the adsorbents in each column be packed to a constant level. A minimum of ten taps with a soft rubber hammer at different points up and down and 25 taps on top of each column should be employed to achieve constant level. A suitable rubber hammer may be assembled by fastening two No. 7 or 8 rubber stoppers on one end of a small rod about 200-mm long. Use fresh adsorbents for each determination.

8.1.2 If *n*-pentane insolubles were not determined, select the appropriate sample size in accordance with the following polar content ranges, if the proper range can be anticipated; otherwise, use a 10 ± 0.5 g sample.

Polar Content Range, mass percent	Sample Size, g
0–20	10 ± 0.5
Above 20	5 ± 0.2

8.1.3 Dilute with 25 mL of *n*-pentane solvent and mix well

to ensure a uniform solution of the sample. The sample should not display precipitate or flocculate at this point. If a precipitate is present *asphaltenes* may be removed by the procedure of Appendix X1, however, the precision statement no longer applies. It is important that the polar content result obtained be not greater than that for the sample size as specified above, since the capacity of the clay for retaining polar constituents becomes limited at these concentrations. If results exceed this specification, repeat the test using a smaller sample. Partitioning between aromatics and polar compounds is affected by sample size. Results using different sample size may not be equivalent.

NOTE 2—For viscous oils, dilutions of the sample with 25 mL of cyclohexane is more convenient and does not affect the results. Cyclohexane used in this manner will not detect small quantities of *asphaltenes*, however.

8.1.4 Add 25 mL of *n*-pentane to the top of the clay portion of the assembled column and allow to percolate into the clay. As soon as nearly all of the *n*-pentane has entered the clay, charge to the column the diluted sample of 8.1.1. Wash the sample beaker (or flask) with *n*-pentane and add the washings to the column. After nearly all of this material has entered the clay, wash the walls of the column above the clay free of

sample with *n*-pentane. The sample and eluent solvent can be added to the column through a 65-mm diameter, wide-stem funnel (the funnel can be left on top of the column). At no time during the run should air be allowed to enter the clay bed.

8.1.5 When nearly all of the washings have entered the clay, charge *n*-pentane to the column and maintain a head level well above the clay beds (Note 3) to wash the saturate portion of the sample from the adsorbents. Recover 280 ± 10 mL of the first *n*-pentane effluent from the column in a graduated, 500-mL wide-mouth conical flask.

NOTE 3—Columns may be briefly separated, if necessary, to give a solvent head 5- to 10-mm deep in the second (lower) column. Loss of the head will give channeling in the lower column, with inaccurate results.

NOTE 4—With long use, the frits in the absorption columns become progressively less porous. If the time for percolation doubles over that for a new column, the slow columns are to be discarded.

8.1.6 Disconnect the two sections. Allow the lower section to drain into a receiver. Continue washing the upper clay section with *n*-pentane. Maintain a moderate liquid head level above the clay during this wash and adjust *n*-pentane additions so that the level is about 25 mm when 150 mL have been collected in the receiver. Discontinue additions at this point and allow the liquid to essentially drain from the column. The quantity in the receiver should then be about 200 mL. The *n*-pentane from this step and from the draining of the lower column should be discarded if aromatics are to be determined by difference. This *n*-pentane should be added to the aromatics solution from the gel column during solvent evaporation (8.3) if aromatics are to be recovered.

NOTE 5—This extra *n*-pentane washing of the clay section is necessary in order to ensure complete removal of aromatics from the clay.

8.1.7 After *n*-pentane effluent has essentially drained from the column, charge a 50 to 50 volume mixture of toluene–acetone. Collect the effluent in a 500-mL separatory funnel. Collect 250 mL of the toluene–acetone (plus *n*-pentane) effluent or until the effluent is practically colorless (only in exceptional cases will more than 300 mL of effluent be required).

8.1.8 Stopper the separatory funnel containing the toluene–acetone fraction and swirl it a few times to aid in settling the water. Then let it stand for about 5 min. Drain off and discard the lower (aqueous) layer. Add approximately 10 g of anhydrous calcium chloride granules to the fraction remaining in the separatory funnel and shake for about 30 s; vent frequently during the shaking period. Allow the mixture to settle for at least 10 min.

8.1.9 Filter the fraction through a rapid folded filter paper catching the filtrate in a 500-mL conical flask. Rinse the separatory funnel with approximately 25 mL of *n*-pentane, filter and collect with the mixed solvent fraction. Wash the filter paper with an additional 10 to 15 mL of *n*-pentane and collect with the mixed solvent fraction. **IMPORTANT**—Make all transfers of organic solvents from the separatory funnels through the top and avoid transferring any water that may have accumulated around the calcium chloride.

8.2 Desorption of Aromatics:

8.2.1 If it is desired to determine the aromatics by isolation rather than by difference, the gel column (lower column of the clay gel adsorption column of 8.1, Fig. 2), after the 280 ± 10

mL of *n*-pentane have been collected, is placed in the extraction assembly of Fig. 3.

8.2.2 Toluene (200 ± 10 mL) is placed in the 500-mL flask and refluxed at such a rate of 10 ± 2 mL/min for 2 h.

NOTE 6—Toluene reflux can be measured by collection for a 1 min period using a graduated cylinder through valve A, Fig. 3.

8.2.3 At the end of this time, the valve (A) is opened and the toluene removed into a waste solvent receiver to a volume of approximately 50-mL in the flask. The solution remaining is then combined with the *n*-pentane from 8.1.6 for recovery of aromatics. Do not go further by distillation, as oil will be lost, giving inaccurate results.

8.3 Solvent Removal:

8.3.1 Label and weigh for tare the anti-creep beakers that are to be used for the evaporation of solvent (one each for polar compounds, saturates, and aromatics desorbed). Fill the anti-creep beakers approximately half full with the respective solutions, (saturates from 8.1.4, aromatics from 8.1.6 and 8.2.3, polars from 8.1.8), then place them on the controlled hot plate at surface temperature of 100 to 105°C, refilling as this volume is reduced to one-quarter full. A gentle sweep may be used over the surface of the liquid. It should not ruffle the surface nor should this nitrogen jet be placed below the surface. The flasks which contained the fractions should be rinsed with *n*-pentane, and this *n*-pentane added to the respective anti-creep beakers. To avoid a potential safety incident, it is recommended that the anti-creep beakers be temporarily removed from the hot plate when transfers are made, such as when the *n*-pentane rinsings are added, before placing the anti-creep beakers back onto the hot plate.

8.3.2 When essentially all the solvent is evaporated, weigh the beakers at 10 min intervals. Solvents are considered removed when the weight loss between weighings is less than 10 mg.

9. Calculation

9.1 Calculate the amount of *n*-pentane insolubles, saturates, aromatics, and polar compounds in the sample as follows:

$$\text{Saturates, mass \%} = (B/A) \times 100 \quad (1)$$

$$\text{Aromatics, mass \%} = (C/A) \times 100 \quad (2)$$

$$\text{Polar compounds (Note 11), for 10 g sample} = (D/A) \times 100 \quad (3)$$

$$\text{Polar compounds, mass \% for 5 g sample} = [(0.88 \times D/A)] \times 100 \quad (4)$$

where:

A = grams of original sample used,

B = grams of residue from *n*-pentane effluent from the clay gel column (8.1.4),

C = grams of residue from the toluene desorption of the lower column and from the last *n*-pentane rinse of the columns (8.1.6 and 8.2.3), and

D = grams of residue from toluene–acetone effluent (8.1.8).

NOTE 7—The factor included in the calculation for the 5 g sample is established experimentally to maintain continuity of results over a wide



range of polar compounds in rubber extender oils.

9.2 The total mass of all the recovered fractions must equal at least 97 % of the sample charged. If this recovery is not obtained, repeat the test.

9.3 If aromatics were not desorbed, use the *n*-pentane insolubles, saturates content, and polar compounds as determined in 9, calculate the amount of aromatics as follows:

$$\text{Aromatics, mass \%} = 100 - (E + F). \quad (5)$$

where:

E = mass % saturates, and

F = mass % polar compounds.

10. Report

10.1 Report the following information:

10.1.1 Sample identification.

10.1.2 Saturate content, aromatic content, and polar content in mass% .

10.1.3 Method of determination of aromatic content: desorption (8.1.9) or difference (9.2).

10.1.4 If aromatics were desorbed, the percent recovery (11.3).

10.1.5 Asphaltene content if the method of Appendix X1 was used.

11. Precision and Bias ¹³

11.1 The precision of this test method as determined by statistical examination of interlaboratory results is as follows:

11.1.1 *Repeatability*—The difference between two test results, obtained by the same operator with the same apparatus

under constant operating conditions on identical test material, would in the long run, in the normal and correct operation of the test method, exceed the following values only in one case in twenty:

Saturate content, mass %	2.1
Aromatic content, mass%	2.3
Polar content, mass %	
at polar contents of less than 1 %	0.24
at polar contents of 1 to 5 %	0.81
at polar contents of greater than 5 %	1.2

11.1.2 *Reproducibility*—The difference between two single and independent results obtained by different operators working in different laboratories on identical test material would, in the long run, in the normal and correct operation of this test method, exceed the following values only in one case in twenty:

Saturate content, mass %	4.0
Aromatic content, mass%	3.3
Polar content, mass %	
at polar contents of less than 1 %	0.4
at polar contents of 1 % to 5 %	1.3
at polar contents of greater than 5 %	1.8

11.1.3 The above precision statements do not include samples that have been prepared by removal of asphaltenes (Appendix X1). The precision on such samples is poorer than the statements above.

11.2 *Bias*—The procedure for measuring saturates, aromatic, and polar contents has no bias because the values are defined only in terms of this test method.

12. Keywords

12.1 clay-gel absorption; elution chromatography; hydrocarbon type; liquid chromatography; petroleum derived oils; rubber extender oils; rubber processing oils

ANNEX

(Mandatory Information)

A1. AZOBENZENE ACTIVITY TEST FOR CLAY

A1.1 Scope

A1.1.1 This test method describes a procedure for measuring the adsorption activity of percolation type clays.

A1.2 Summary of Test Method

A1.2.1 A solution of 1 mass % azobenzene in *isooctane* is percolated through a weighed amount of clay contained in a specified column. The amount of liquid recovered as percolate at the point where the concentration of azobenzene is 0.5 mass % (50 mass % of the original concentration) is a measure of the adsorption activity of the clay.

A1.3 Apparatus

A1.3.1 *Azobenzene Percolation Column*, glass constructed from 12.0-mm outside diameter and 6.0-mm outside diameter standard glass tubing with a reservoir of approximately 125 mL

near the top. The top of the column shall be a female spherical ground-glass joint. The bottom of the column has a stopcock with internal metering valve attached by means of a standard taper joint. The entire percolation assembly is illustrated in Fig. A1.1.

A1.3.2 *Graduated Cylinders*, 5 or 10-mL capacity, 0.1-mL graduation.

A1.3.3 *Gas or Air Pressure System*, regulated.

A1.3.4 *Vibrator*, electric. The type of tungsten carbide tipped vibrating pencil used for marking glass is satisfactory if a rubber stopper is slipped over the tip.

A1.3.5 *Spectrophotometer*, capable of operation at 446-mm wavelength,¹⁴ equipped with a 1-mm (or 0.5-mm) thickness cell.

¹⁴ A Bausch and Lomb Spectronic 20 has been found suitable for this purpose.

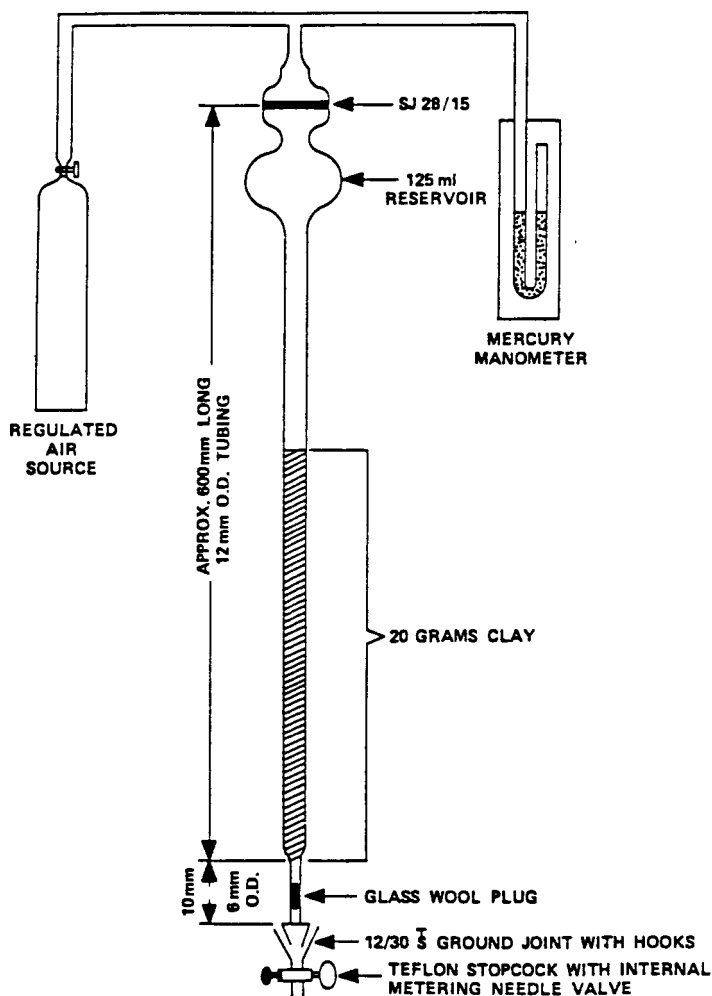

FIG. A1.1 Azobenzene Percolation Assembly

A1.4 Reagents

A1.4.1 *Azobenzene Solution (1 %)*, prepared by dissolving 10 ± 0.001 g of c.p. azobenzene in 990 g of isooctane. (**Warning**—Azobenzene is a suspect carcinogen. *Isooctane* is flammable.)

A1.5 Procedure

A1.5.1 Insert a small piece of glass wool into the bottom of the glass column (6.0-mm outside diameter tubing) and move it up the tubing until top surface is 25 mm (1 in.) from the joint of the two glass sections (see Fig. A1.1).

NOTE A1.1—Insert a sufficient amount of glass wool to hold in place. Fold the glass wool to produce a smooth surface for the top of the plug.

A1.5.2 Weigh 20 ± 0.001 g of clay sample and pour it into the column.

A1.5.3 Pack the clay in the column to a constant level by using an electric vibrator.

NOTE A1.2—A satisfactorily packed column will be achieved by lightly holding the vibrator next to the column and moving it up and down over the clay height. Perform the “up and down” vibrations at 4 points approximately 90° spacings around the column.

A1.5.4 Add 100–115 mL of azobenzene solution to the column.

A1.5.5 Collect percolate in graduated 5 or 10-mL cylinders. Maintain the percolation rate at 1 mL/min. The rate control shall be approximately established after 3 mL have been collected and well established by the time 5 mL of eluent have been collected. Determine additional rate checks periodically throughout the test. If the rate is too fast, adjust the needle valve as necessary to maintain the specified rate. If the rate is found to be below the prescribed limit, connect the pressure line to the top of the column and apply pressure to adjust to the specified rate. (**Warning**—Normally only light pressure will be required; that is 5 to 15 mm Hg. At test termination, the number of minutes required to collect the eluent should not differ from the millilitres of eluent collected by more than two.)

A1.5.6 After 25 mL of effluent has been collected, collect at least 6 samples sequentially of 2 mL each. Measure the azobenzene concentration of these samples using the Spectrometer which has been previously calibrated with known concentrations of azobenzene in *isooctane*, using a wavelength of 446 nm.

A1.5.7 Plot the effluent azobenzene concentration versus the effluent volume, and graphically determine the effluent volume at 0.5 mass % azobenzene concentration (50 % of the starting solution concentration). This is the azobenzene equivalence of the clay.



A1.6 Interpretation of Results

A1.6.1 The average of duplicate determinations of azobenzene equivalence is used to determine the suitability of a clay for use in this test method. If the duplicate azobenzene equivalence values differ by more than 1 mL, make a third determination and use the average of all three.

A1.6.2 A Clay with an average azobenzene equivalence between 30 and 35 meets the activity criterion (see 7.3). Clay

with azobenzene equivalence values outside this range is not suitable for use in this test method.

A1.7 Precision and Bias

A1.7.1 No statement is made about either the precision or the bias of this procedure for determining the azobenzene equivalence of clay since the result merely states whether there is conformance to the criteria specified in this test method.

APPENDIX

(Nonmandatory Information)

X1. PROCEDURE FOR SAMPLES WITH PRECIPITATES OR FLOCCULATE

X1.1 Removal of Asphaltenes

If the diluted sample of 8.1.9 is not free from precipitates or flocculate, an approximation of the characteristic groups can be obtained by the following procedure:

X1.1.1 Weigh 10 ± 0.5 g of the sample to the nearest 0.5 mg in a preweighed 250-mL conical flask, add 100 mL of *n*-pentane and mix well. Warm the mixture in a warm water bath for a few seconds with intermittent swirling to hasten solution. Allow the mixture to stand about 30 min at or near room temperature. Samples containing a high content of insolubles may require more agitation to dissolve the *n*-pentane-soluble portion. In such cases, use a stirring rod, together with intermittent warming and swirling to hasten solution of the sample. Solution should be cooled to room temperature before filtering.

X1.1.2 Set up a filtering assembly, using a 500-mL flask, a 125-mm borosilicate filtering funnel equipped with a folded rapid 15-cm filter paper, and filter the sample. Rinse the conical flask and stirring rod with 60-mL *n*-pentane, and pour the rinse through the paper filter.

X1.1.3 Rinse the filter paper and contents with 60 mL of *n*-pentane in small portions from a dispensing bottle, taking care to rinse down the sides of the filter paper.

X1.1.4 Transfer the solution to an anti-creep beaker in portions and evaporate the *n*-pentane on a hot plate at a temperature of 100–105°C. Rinse the flask with small portions of *n*-pentane, adding these rinsings to the anti-creep beaker. *n*-Pentane shall be considered removed when the change in weight is less than 10 mg in 10 min at this temperature. Slow nitrogen flows over the beaker can be used to assist the evaporation, but rapid stirring by the gas should be avoided.

X1.1.5 Weigh the recovered oil. The weight of sample (7.1) less the weight of the oil is the *asphaltenes* content. This oil can then be diluted for charge to the clay-gel column (6.2).

X1.2 Precision and Bias

X1.2.1 The precision of this test method was determined by a round robin of too few samples to meet the requirements of Practice E 691. However, it can be approximated as:

Repeatability: 1.3 %;
Reproducibility: 7.8 %.

X1.2.2 *Bias*—There is insufficient interlaboratory test data to establish a statistical statement of bias for the procedure in Appendix X1 of Test Method D 2007.

SUMMARY OF CHANGES

Committee D02.04 has identified the location of selected changes to this standard since the last issue of D 2007 – 01 that may impact the use of this standard.

(1) The safe handling of the anti-creep beakers in paragraph 8.3.1 was specified.

(2) Figure 1 (Anti-Creep Beaker) was added.

**NOTICE: This standard has either been superseded and replaced by a new version or discontinued.
Contact ASTM International (www.astm.org) for the latest information.**



ASTM International takes no position respecting the validity of any patent rights asserted in connection with any item mentioned in this standard. Users of this standard are expressly advised that determination of the validity of any such patent rights, and the risk of infringement of such rights, are entirely their own responsibility.

This standard is subject to revision at any time by the responsible technical committee and must be reviewed every five years and if not revised, either reapproved or withdrawn. Your comments are invited either for revision of this standard or for additional standards and should be addressed to ASTM International Headquarters. Your comments will receive careful consideration at a meeting of the responsible technical committee, which you may attend. If you feel that your comments have not received a fair hearing you should make your views known to the ASTM Committee on Standards, at the address shown below.

This standard is copyrighted by ASTM International, 100 Barr Harbor Drive, PO Box C700, West Conshohocken, PA 19428-2959, United States. Individual reprints (single or multiple copies) of this standard may be obtained by contacting ASTM at the above address or at 610-832-9585 (phone), 610-832-9555 (fax), or service@astm.org (e-mail); or through the ASTM website (www.astm.org).