



# Standard Test Method for Oxidation Stability of Steam Turbine Oils by Rotating Pressure Vessel<sup>1</sup>

This standard is issued under the fixed designation D 2272; the number immediately following the designation indicates the year of original adoption or, in the case of revision, the year of last revision. A number in parentheses indicates the year of last reapproval. A superscript epsilon ( $\epsilon$ ) indicates an editorial change since the last revision or reapproval.

*This standard has been approved for use by agencies of the Department of Defense.*

<sup>1</sup> This test method is under the jurisdiction of ASTM Committee ~~D-2~~ D02 on Petroleum Products and Lubricants and is the direct responsibility of Subcommittee D02.09 on Oxidation.

Current edition approved ~~June August 10, 1998; 2002~~. Published ~~November 1998; October 2002~~. Originally published as D 2272-64 T. Last previous edition D 2272-94~~8~~.

## 1. Scope

1.1 This test method<sup>2</sup> utilizes an oxygen-pressured vessel to evaluate the oxidation stability of new and in-service turbine oils having the same composition (base stock and additives) in the presence of water and a copper catalyst coil at 150°C.

1.2 The values stated in ~~acceptable~~ SI units are to be regarded as the standard.

1.3 *This standard does not purport to address all of the safety concerns, if any, associated with its use. It is the responsibility of the user of ~~the~~ this standard to establish appropriate safety and health practices and determine the applicability of regulatory limitations prior to use.* For specific warning statements, see 6.2, 6.4, 6.5, 6.6, 6.10, and 6.11.

## 2. Referenced Documents

### 2.1 ASTM Standards:

B 1 Specification for Hard-Drawn Copper Wire<sup>3</sup>

D 235 Specification for Mineral Spirits (Petroleum Spirits) (Hydrocarbon Dry Cleaning Solvent)<sup>4</sup>

~~D-329 Specification for Acetone<sup>4</sup>~~

~~D-770 Specification for Isopropyl Alcohol<sup>4</sup>~~

~~D 943 Test Method for Oxidation Characteristics of Inhibited Mineral Oils<sup>5</sup>~~

D 1193 Specification for Reagent Water<sup>6</sup>

D 2112 Test Method for Oxidation Stability of Inhibited Mineral Insulating Oil by ~~Rotating Bomb~~ Pressure Vessel<sup>7</sup>

D 4057 Practice for Manual Sampling of Petroleum and Petroleum Products<sup>8</sup>

D 4742 Test Method for Oxidation Stability of Gasoline Automotive Engine Oils by Thin-Film Oxygen Uptake (TFOUT)<sup>8</sup>

~~E 1 Specification for ASTM Thermometers<sup>9</sup>~~

### 2.2 British Standard:<sup>9</sup>

<sup>2</sup> von Fuchs, G. H., Claridge, E. L., and Zuidema, H. H., "The Rotary Bomb Oxidation Test for Inhibited Turbine Oils," *Materials Research and Standards*, MTRSA (formerly ASTM Bulletin), No. 186, December 1952, pp. 43-46; von Fuchs, G. H., "Rotary Bomb Oxidation Test<sup>2</sup>," *Lubrication Engineering*, Vol 16, No. 1, January 1960, pp. 22-31.

<sup>3</sup> *Annual Book of ASTM Standards*, Vol 02.03.

<sup>4</sup> *Annual Book of ASTM Standards*, Vol 06.04.

<sup>5</sup> *Annual Book of ASTM Standards*, Vol 05.01.

<sup>6</sup> *Annual Book of ASTM Standards*, Vol 11.01.

<sup>7</sup> *Annual Book of ASTM Standards*, Vol 10.03.

<sup>8</sup> *Annual Book of ASTM Standards*, Vol 05.02.

*Annual Book of ASTM*

<sup>9</sup> Available from British Standards, ~~Vol 14-03~~. Institute, 389 Chiswick High Rd., London, W4 4AL, United Kingdom.

B2 2000 Part 0: Section 0.1,  
 IP 37C Thermometer  
 2.3 Institute of Petroleum Standard.<sup>10</sup>  
 IP 229

### 3. Summary of Test Method

3.1 The test oil, water, and copper catalyst coil, contained in a covered glass container, are placed in a vessel equipped with a pressure gage. The vessel is charged with oxygen to a gage pressure of 620 kPa (90 psi, 6.2 bar) (see ~~Note Eq 1~~), placed in a constant-temperature oil bath set at 150°C, and rotated axially at 100 rpm at an angel of 30° from the horizontal. The number of minutes required to reach a specific drop in gage pressure is the oxidation stability of the test sample. ~~NOTE 1—100 kPa = 1.00 bar = 14.5 psi.~~

$$100 \text{ kPa} = 1.00 \text{ bar} = 14.5 \text{ psi} \quad (1)$$

### 4. Significance and Use

4.1 The estimate of oxidation stability is useful in controlling the continuity of this property for batch acceptance of production lots having the same operation. It is not intended that this test method be a substitute for Test Method D 943 or be used to compare the service lives of new oils of different compositions.

4.2 This test method is also used to assess the remaining oxidation test life of in-service oils.

~~NOTE 2~~—A modification of the rotating vessel method has been published as Test Method D 2112, which uses a similar procedure and apparatus but a lower (140°C) bath temperature. Test Method D 2112 requires duplicate testing and Test Method D 2272 conducted duplicate testing in the past.

### 5. Apparatus

5.1 *Oxidation Vessel, Glass Sample Container with Four-Hole PTFE Disk, Hold-Down Spring, Catalyst-Coil, Pressure Gage, Thermometer, and Test Bath*, as described in Annex A1. The assembled apparatus is shown schematically in Fig. 1 and Fig. A1.6.

### 6. Reagents and Materials

6.1 *Purity of Reagents*—Reagent grade chemicals shall be used in all tests. Unless otherwise indicated, it is intended that all reagents shall conform to the specifications of the ~~Committee on Analytical Reagent-grads of the American Chemical Society~~ where such specifications are available.<sup>11</sup> Other grades may be used, provided it is first ascertained that the reagent is of sufficiently high purity to permit its use without lessening the accuracy of the determination.

<sup>10</sup> Available from British Standards Institute, 2 Park ~~Institute of Petroleum, 61 New Cavendish St., London, England W1A2B5; W1G 7AR, United Kingdom.~~

<sup>11</sup> Available from ~~Institute~~

<sup>11</sup> ~~Reagent Chemicals, American Chemical Society Specifications, American Chemical Society, Washington, DC. For suggestions on the testing of Petroleum, 61 New Cavendish St., London, W. I., England;~~ reagents not listed by the American Chemical Society, see *Analar Standards for Laboratory Chemicals*, BDH Ltd., Poole, Dorset, U.K., and the *United States Pharmacopeia and National Formulary*, U. S. Pharmacopeial Convention, Inc. (USPC), Rockville, MD.

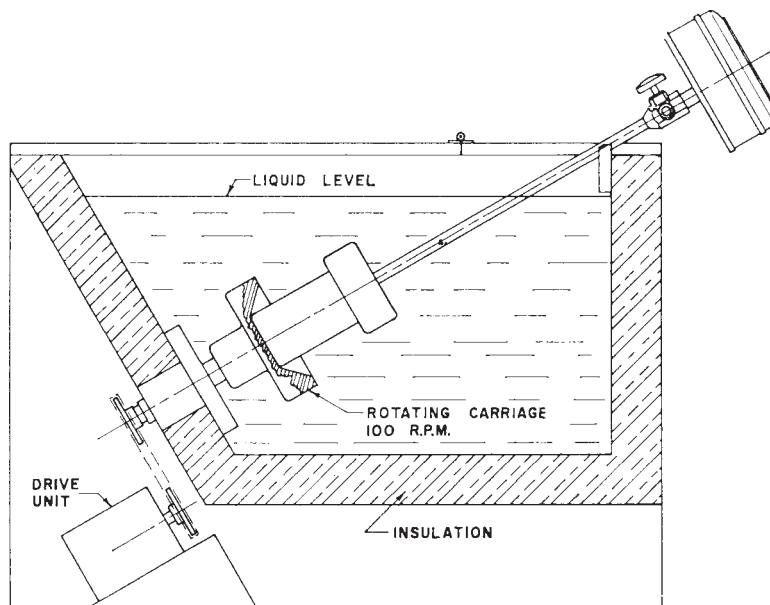

FIG. 1 Schematic Drawing of the Rotary Vessel Test Apparatus

6.2 *Isopropyl Alcohol, reagent grade.* (~~Warning—Flammable. Health hazard.~~), ~~99 % refined, conforming to Specification D 770. hazard.~~

6.3 *Liquid Detergent.*

6.4 *n-Heptane, 99.0 minimum mol % (pure grade).* (~~Warning—Flammable. Health hazard.~~), ~~99.0 minimum mol % (pure grade). hazard.~~

6.5 *Oxygen*, 99.5 %, with pressure regulation to 620 kPa (90 psi, 6.2 bar). (~~Warning—Vigorously accelerates combustion.~~)

6.6 *Potassium Hydroxide, Alcohol Solution (1 %)*—Dissolve 12 g of potassium hydroxide (KOH) pellets in 1 L of the isopropyl alcohol. (~~Warning—Flammable. Health hazard.~~)

6.7 *Silicone Carbide Abrasive Cloth*, 100-grit with cloth backing.

6.8 *Silicone Stopcock Grease.*

6.9 *Wire Catalyst, Electrolytic Copper Wire*,  $1.63 \pm 1 \text{ mm}$  ( $0.064 \pm 1 \text{ in.}$ ) in diameter (No. 16 Imperial Standard Wire Gage or No. 14 American Wire Gage, 99.9 % purity, conforming to Specification B 1. Soft copper wire of an equivalent grade may also be used.

6.10 *Petroleum Spirit*, ~~(, conforming to Specification D 235 for petroleum spirit (mineral spirits). (Warning—Combustible. Health hazard.) Conforming to Specification D 235 for petroleum spirit (mineral spirits). hazard.)~~

6.11 *Acetone*, ~~(, reagent grade. (Warning—Flammable. Health hazard.) Conforming to Specification D 329). hazard.)~~

6.12 *Reagent Water*, conforming to Specification D 1193, Type II.

## 7. Sampling

7.1 Samples for this test method can come from tanks, drums, small containers, or even operating equipment. Therefore, use the applicable apparatus and techniques described in Practice D 4057.

## 8. Preparation of Apparatus

8.1 *Catalyst Preparation*—Before use, polish approximately 3 m of the copper wire with a silicon carbide abrasive cloth and wipe free from abrasives with a clean, dry cloth. Wind the wire into a coil having an outside diameter 44 to 48 mm and weight of  $55.6 \pm 0.3 \text{ g}$  and stretched to a height of 40 to 42 mm. Clean the coil thoroughly with isopropyl alcohol, air-dry, and insert inside the glass sample container by a turning motion, if necessary. A new coil is used for each sample. For extended storage, the prepared coil may be packaged in a dry, inert atmosphere. For overnight storage (less than 24 h), the coils may be stored in *n*-~~h~~Heptane.

NOTE 32—Commercially available and prepackaged coils prepared as described in 8.1 can also be used for the test.<sup>12</sup>

8.2 *Cleaning of Vessel*—Wash the vessel body, cap, and inside of vessel stem with hot detergent solution and rinse thoroughly with water. Rinse the inside of the stem with isopropyl alcohol and blow dry with clean compressed air. If the vessel body, cap, or inside of the stem smells sour after simple cleaning, wash with 1 % alcoholic KOH solution and repeat as ~~before~~.

NOTE 4—~~Caution:~~ **before.** (~~Warning—~~Failure to remove oxidation residue can adversely affect test results.)

8.3 *Cleaning of Glass Container*—Drain and rinse with a suitable solvent (for example, petroleum spirit or acetone). Soak or scrub in an aqueous detergent solution. Brush thoroughly and flush thoroughly with tap water. Rinse with isopropyl alcohol, followed by distilled water and air dry. If any insolubles remain, soak overnight in an acid-type cleaning solution and repeat the above procedure starting from the tap water flush.

8.4 *Cleaning of Polytetrafluoroethylene (PTFE) Disk*—Remove any residual oil with a suitable solvent and clean by brushing with detergent solution. Rinse thoroughly with tap water, followed by distilled water rinse and air dry.

## 9. Procedure

9.1 *Charging*—Weigh the glass sample container with a freshly cleaned catalyst coil. Weigh  $50 \pm 0.5 \text{ g}$  of oil sample into the container; also add 5 mL of reagent water. Add another 5 mL of reagent water to the vessel body and slide ~~and~~ the sample container into the vessel body (see Note ~~5~~; 3). Cover the glass container with a 57.2-mm (2 1/4-in.) PTFE disk and place a hold-down spring<sup>13</sup> on top of the PTFE disk. Apply a thin coating of silicone stopcock grease to the O-ring vessel seal located in the gasket groove of the vessel cap to provide lubrication, and insert the cap into the vessel body.

NOTE 53—The water between the vessel wall and the sample container aids heat transfer.

9.1.1 Tighten the closure ring by hand. Cover the threads of the gage-nipple with a thin coating of stopcock grease (PTFE pipe tape is a suitable alternative to the use of stopcock grease) and screw the gage into the top center of the vessel stem. Attach the

~~Reagent Chemicals, American Chemical Society Specifications, American Chemical Society, Washington, DC. For suggestions on testing of reagents not listed by the American Chemical Society, see *Analar Standards*~~

<sup>12</sup> Prepackaged coils were provided for Laboratory Chemicals, BDH Ltd., Poole, Dorset, U.K., and the *United States Pharmacopeia and National Formulary*, U. S. Pharmacopeial Convention, Inc. (USPC), Rockville, MD; Spring 1995 round robin.

<sup>13</sup> Prepackaged coils

<sup>13</sup> PTFE disk with 4-holes and hold down spring were provided for Spring 1995 round robin.

oxygen line with an inline pressure gage to the inlet valve on the vessel stem. Slowly turn on the oxygen supply valve until the pressure has reached 620 kPa (90 psi, 6.2 bar). Turn off the oxygen supply valve. Slowly release pressure by loosening the fitting or by using an inline bleeder valve. Repeat purging process two more times; purge step should take approximately 3 min. Adjust the regulating valve on the oxygen supply tank to 620 kPa (90 psi, 6.2 bar) at a room temperature of 25°C (77°F). For each 2.0°C (3.6°F) above or below this temperature, 5 kPa (0.7 psi, 0.05 bar) shall be added or subtracted to attain the required initial pressure. Fill the vessel to this required pressure and close the inlet valve securely by hand. If desired, test the vessel for leaks by immersing in water (see Note 6 4).

NOTE 64—If the vessel was immersed in water to check for leaks, dry the outside of the wet vessel by any convenient means such as airblast or a towel. Such drying is advisable to prevent subsequent introduction of free water into the hot oil bath which would cause spluttering.

9.2 Oxidation—Bring the heating bath to the test temperature while the stirrer is in operation. Switch off stirrer, insert the vessel into the carriages, and note the time. Restart the stirrer. If an auxiliary heater is used, keep it on for the first 5 min of the run and then turn it off (see Note 7 5). The bath temperature shall stabilize at the test temperature within 15 min after the vessel is inserted. Maintain the test temperature within  $\pm 0.1^\circ\text{C}$  (see Note 8 6).

NOTE 75—The time for the bath to reach the operating temperature after insertion of the vessel may differ for different apparatus assemblies and should be observed for each unit. The objective is to find a set of conditions that does not permit a drop of more than 2°C after insertion of the vessel and allows the vessel pressure to reach a plateau within 30 min as shown in Curve A of Fig. 2.

NOTE 86—Maintaining the correct temperature within the specified limits of  $\pm 0.1^\circ\text{C}$  during the entire test run is an important factor assuring both repeatability and reproducibility of test results.

9.3 Keep the vessel completely submerged and maintain continuous and uniform rotation throughout the test. A standard rotational speed of  $100 \pm 5$  rpm is required; any appreciable variations in this speed could cause erratic results.

9.4 The test is complete after the pressure drops more than 175 kPa (25.4 psi, 1.75 bar) below the maximum pressure (see Note 9 7). The 175 kPa pressure drop usually, but not always, coincides with an induction-type *period of rapid pressure drop*. When it does not, the operator may question whether he has produced a valid experiment (see Note 10 8).

NOTE 97—While termination of the test at a 175 kPa (25.4 psi, 1.75 bar) pressure drop is the standard procedure, some operators may elect to stop the test at lesser pressure drops or to observe the condition of the oil after a predetermined test period of perhaps 100 min; that is, well within the normal induction period of new inhibited oils.

NOTE 10 8—A typical experiment is shown in Fig. 2 as Curve A. The maximum pressure is expected to be reached within 30 min, a pressure plateau is established, and an induction-type pressure drop is observed. Curve B, in which there is a gradual decrease in pressure before the induction break is recorded, is more difficult to evaluate. The gradual decrease in pressure could be due to a vessel leak, although some synthetic fluids will generate this type of curve. If a leak is suspected, repeat the test in a different vessel. If the same type of curve is derived when the test is repeated, the experiment is likely valid.

9.5 After termination of the test, the vessel shall be removed from the oil bath and cooled to room temperature. The vessel can be briefly dipped into and swirled around in a bath of light mineral oil to wash off the adhering bath oil. The vessel is rinsed off with hot water, then immersed into cold water to quickly bring it to room temperature. Alternately, the vessel can be cooled to room temperature in air. The excess oxygen pressure is bled off and the vessel opened.

## 10. Report

### 10.1 Interpretation of Results:

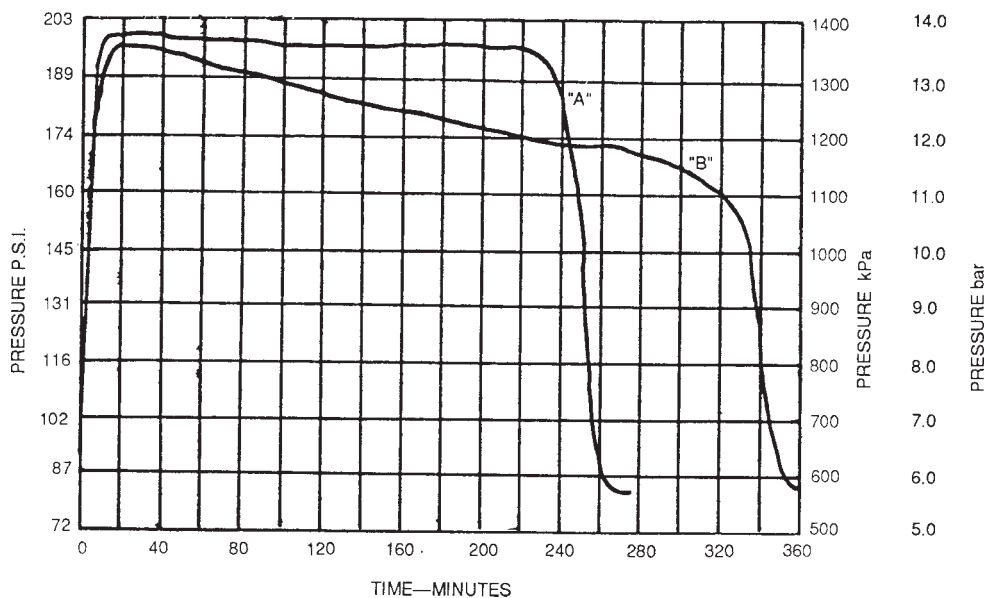

FIG. 2 Pressure Versus Times Plot of Two Rotary Vessel Oxidation Test Runs

10.1.1 In reference to Fig. 2, Curve A, observe the plot of the recorded pressure versus time and establish the plateau (see Note 10). Record the time at the point on the falling part of the curve where the pressure is 175 kPa (25.4 psi, 1.75 bar) less than the established plateau pressure. If the test is repeated, the plateau pressures in repeat tests should not differ by more than 35 kPa (5.1 psi, 0.35 bar).

10.1.2 In reference to Fig. 2, Curve B, observe the plot of the recorded pressure versus time and establish the maximum pressure obtained during the initial 30 min of the experiment (see Note 10). Record the time on the falling part of the curve where the pressure is 175 kPa (25.4 psi, 1.75 bar) less than the established maximum pressure. If the test is repeated, maximum pressures in repeat tests should not differ by more than 35 kPa (5.1 psi, 0.35 bar).

10.2 *Report the Results:*

10.2.1 In reference to Fig. 2, Curve A, the vessel life of the sample is the time in minutes from the start of the test to a 175 kPa (25.4 psi, 1.75 bar) pressure drop from the level of the established plateau.

10.2.2 In reference to Fig. 2, Curve B, the vessel life of the sample is the time in minutes from the start of the test to a 175 kPa (25.4 psi, 1.75 bar) pressure drop from the maximum pressure.

NOTE 11—In reporting test results, it is recommended that it be indicated whether tests were made with stainless steel or chrome-plate copper vessels.

**11. Precision and Bias**<sup>14</sup>

11.1 The precision and bias statement is generated from the research report (95 % confidence). The data range of results in RR:D02-1409 is from 30 to 1000 min.

11.1.1 *Repeatability*—The difference between successive test results obtained by the same operator with the same apparatus under constant operating conditions on identical test material, would in the long run, in the normal and correct operation of the test method, exceed the following values only in one case in twenty:

$$0.12 X \quad (2)$$

where:

X ≡ denotes mean value.

11.1.2 *Reproducibility*—The difference between two single and independent results obtained by different operators working in different laboratories on identical test material, would in the long run, in the normal and correct operation of the test method, exceed the following values only in one case in twenty:

$$0.22 X \quad (3)$$

where:

X ≡ denotes mean value.

NOTE 120—This precision statement was prepared with data on seven oils (an uninhibited base oil and three new and three used steam turbine oils) tested by eleven cooperators. The oils covered values in the ranges from 30 to 1000 min. Oils with results greater than 1000 min exhibited poor precision in the Spring 1995 round robin.

11.2 *Bias*—There being no criteria for measuring bias in these test-product combinations, no statement of bias can be made.

<sup>14</sup> PTFE disk with 4-holes

<sup>14</sup> Supporting data have been filed at ASTM International Headquarters and hold-down spring were may be obtained by requesting Research Report RR: D02-1409. Supporting data are also provided for Spring-1995-round-robin: in Supplement I.

**ANNEX**

**(Mandatory Information)**

**A1. APPARATUS FOR ROTARY PRESSURE VESSEL OXIDATION TEST**

A1.1 *Oxidation Vessel*, with body, cap, closure ring, and stem, constructed as shown in Figs. A1.1-A1.4.

A1.1.1 *Vessel Body and Cap*, shall be constructed of 18-8 or 321S12/321S20 Part 1 (BSI) stainless steel to ensure a proper rate of heat transfer. The interior surface shall be given a smooth finish to facilitate cleaning. Alternatively, the vessel body and cap may be machined from 76.2-mm (3-in.) solid copper rod and then heavily chrome plated.

A1.1.2 *Vessel Stem*, shall be constructed of stainless steel, the stem having an inside diameter of 6.4 mm (1/4 in.) and shall be equipped with a 6.4-mm (1/4-in.) needle valve.

A1.1.3 *Closure Ring*, shall be made of chrome-plated steel or chrome-plated aluminum bronze BS 2032.

A1.1.4 The vessel shall withstand a working pressure of 3450 kPa (500 psi, 34.5 bar) at 150°C.

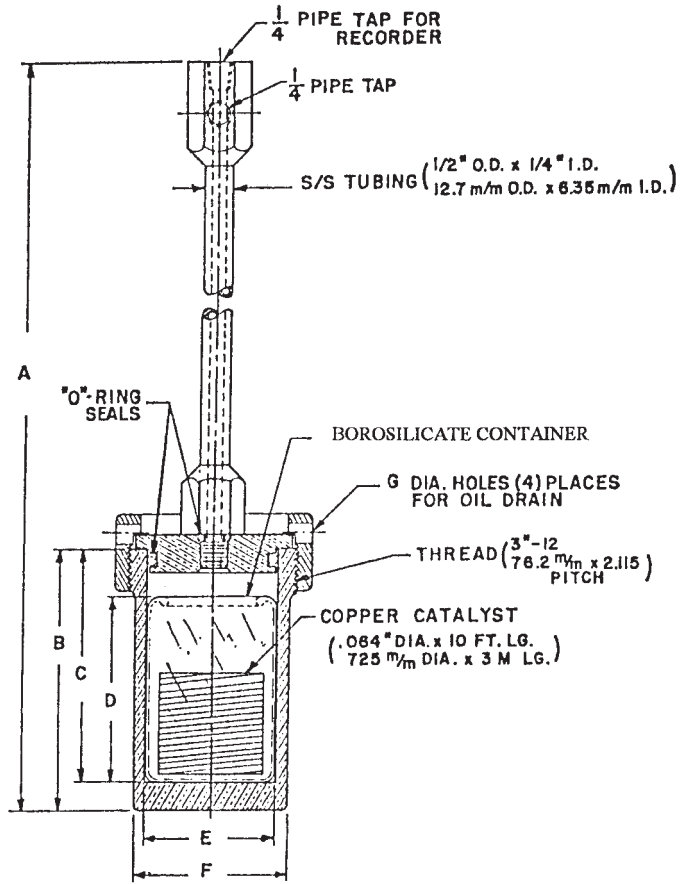

	Inches	Millimeters
A	$2\frac{1}{8}$	536.58
B	$4\frac{3}{4}$	120.65
C	$4\frac{1}{4}$	107.95
D	$3\frac{3}{8}$ to $3\frac{1}{2}$	86 to 89
E	$2.375 \begin{cases} + 0.010 \\ - 0.000 \end{cases}$	60.325/60.579
F	$2\frac{3}{4}$	69.85
G	$\frac{3}{8}$	9.525

FIG. A1.1 Oxidation Vessel

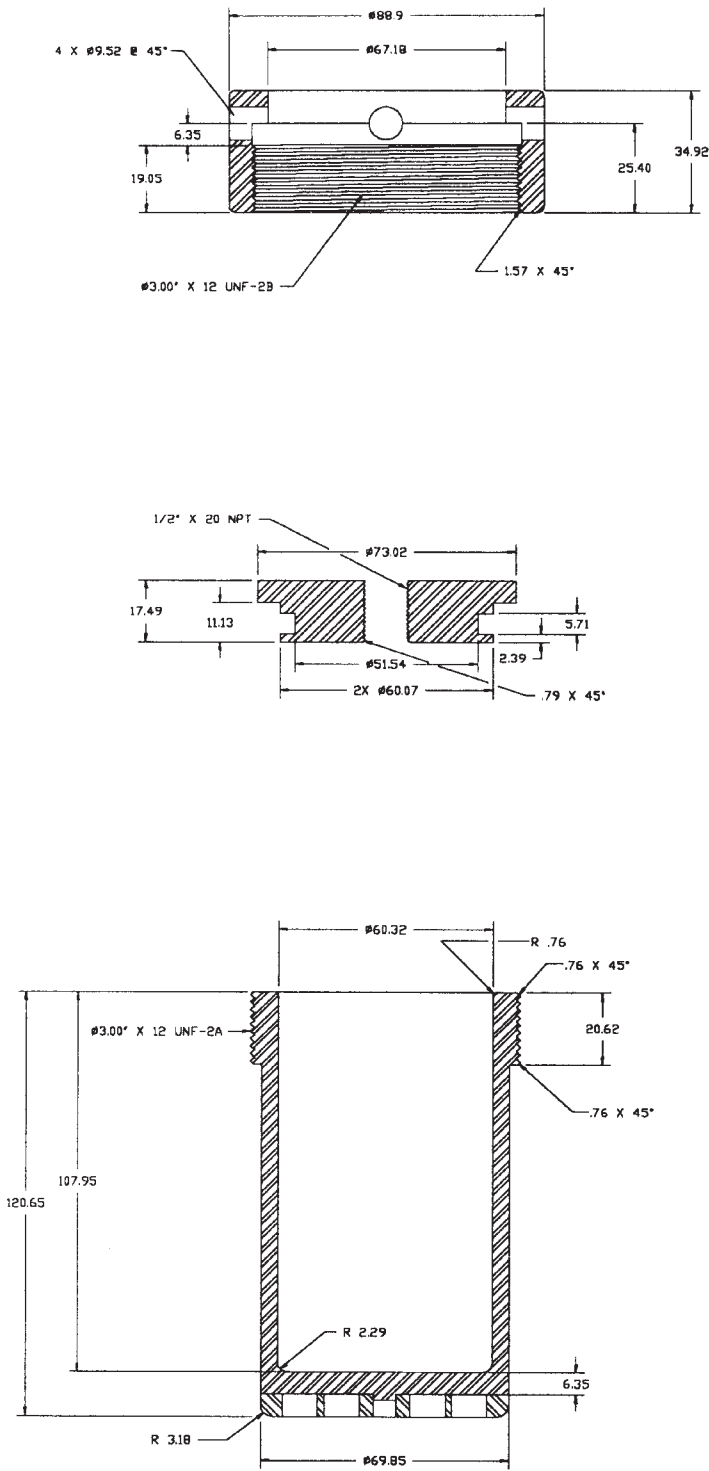

Unless otherwise specified all dimensions in millimeters.

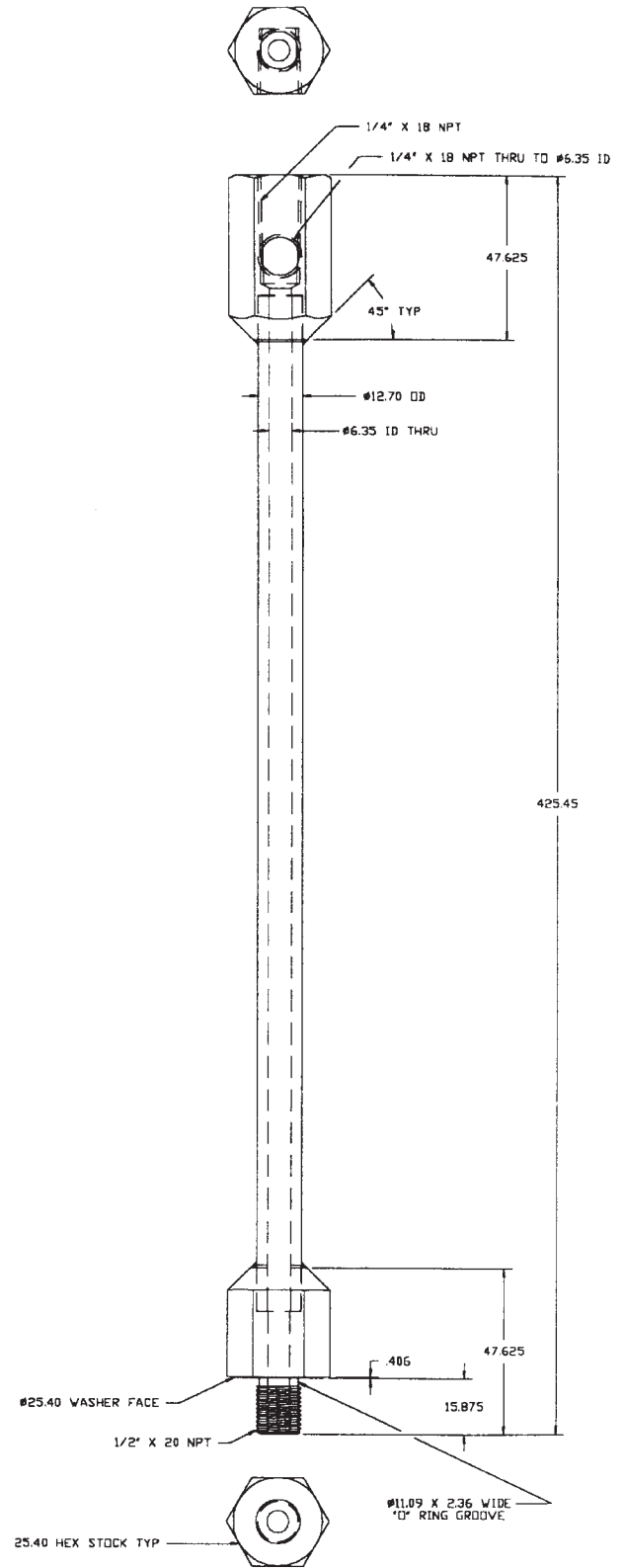

NOTE—The vessel shown in Figs. A1.1 and A1.2 can also be used for Test Method D 4742 (TFOUT). Test Method D 2272 and IP 229 utilize different drive mechanisms for the vessel; hence, US and UK vessels/baths are not interchangeable.

FIG. A1.2 Construction of Oxidation Vessel

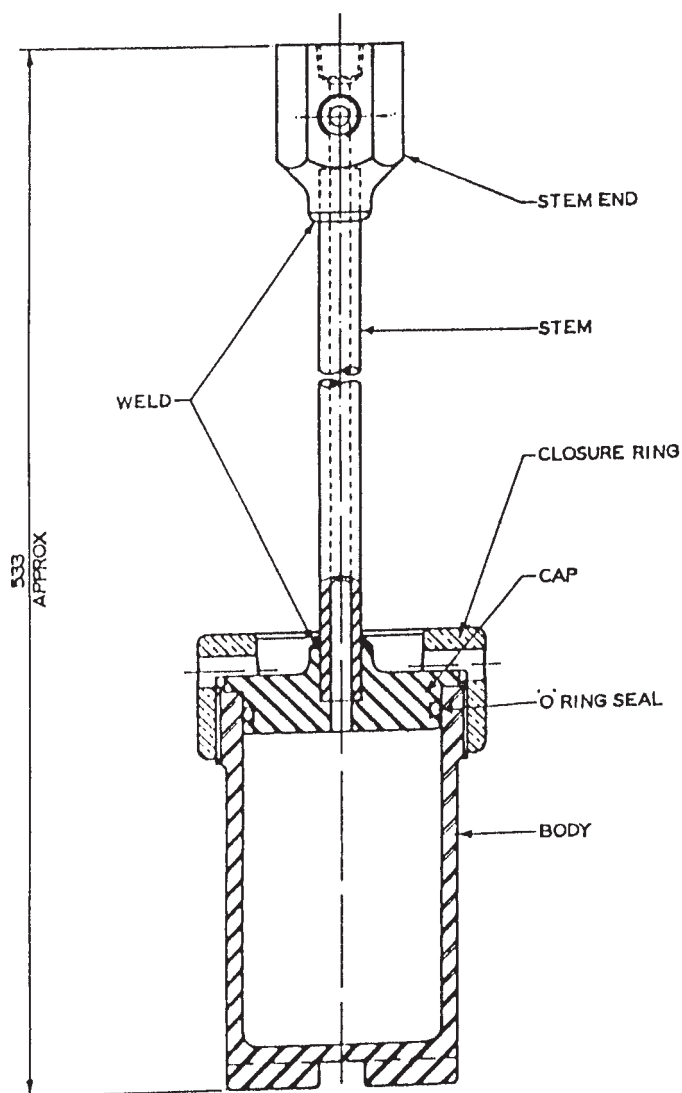

FIG. A1.3 Oxidation Vessel

A1.1.5 *O-ring Gaskets*, Viton or silicon, 50.8 mm (2 in.) in inside diameter by 60.3 mm (2 $\frac{3}{8}$  in.) in outside diameter (BS/USA size No. 329). Caps with larger seal recess diameters will require 54 mm (2 $\frac{1}{8}$  in.) inside diameter by 60.3 mm (2 $\frac{3}{8}$  in.) in outside diameter (BS/USA size No. 227).

A1.2 *Glass Sample Container*, with copper catalyst coil, 175-mL capacity as shown in Fig. A1.5<sub>2</sub> constructed of borosilicate glass. Glass sample container shall have a sliding fit in the vessel with no excess side clearance. The container alone shall have a maximum wall thickness of 2.5 mm and shall weigh no more than 100 g.

A1.2.1 *Top of Sample Container*, shall be covered with 57.2-mm (2 $\frac{1}{4}$ -in.) diameter PTFE disk. The disk will have four 3.2-mm ( $\frac{1}{8}$ -in.) diameter holes evenly spaced in a 9.5-mm ( $\frac{3}{8}$ -in.) radius from the center of the disk. The disk shall have a thickness of 1.6 mm ( $\frac{1}{16}$  in.). A stainless steel hold-down spring as shown in Fig. A1.6 shall be used to ensure rotation of the sample container. The assembly is shown in Fig. A1.7.

### A1.3 *Recording Devices:*

A1.3.1 *Recording Gage*<sup>15</sup>, as shown in Fig. A1.8 or indicating, with a range from 0 to 1400 kPa (or 0 to 200 psi or 0 to 14 bar) and graduated in 25-kPa (or 5 psi or 0.25 bar) divisions. The accuracy shall be 2.5 % or less of the total scale interval. Recording gages should be mounted so that the face is perpendicular to the axis of rotation.

<sup>15</sup> The sole source of supply of the Heiñse gage, Model CM known to the committee at this time is Dresser Industries, 153 South Main St., Newtown, CT 06470. If you are provided in Supplement 1. They are also available from aware of alternative suppliers, please provide this information to ASTM headquarters by requesting RR:D02-1409. International Headquarters. Your comments will receive careful consideration at a meeting of the responsible technical committee<sup>1</sup>, which you may attend.



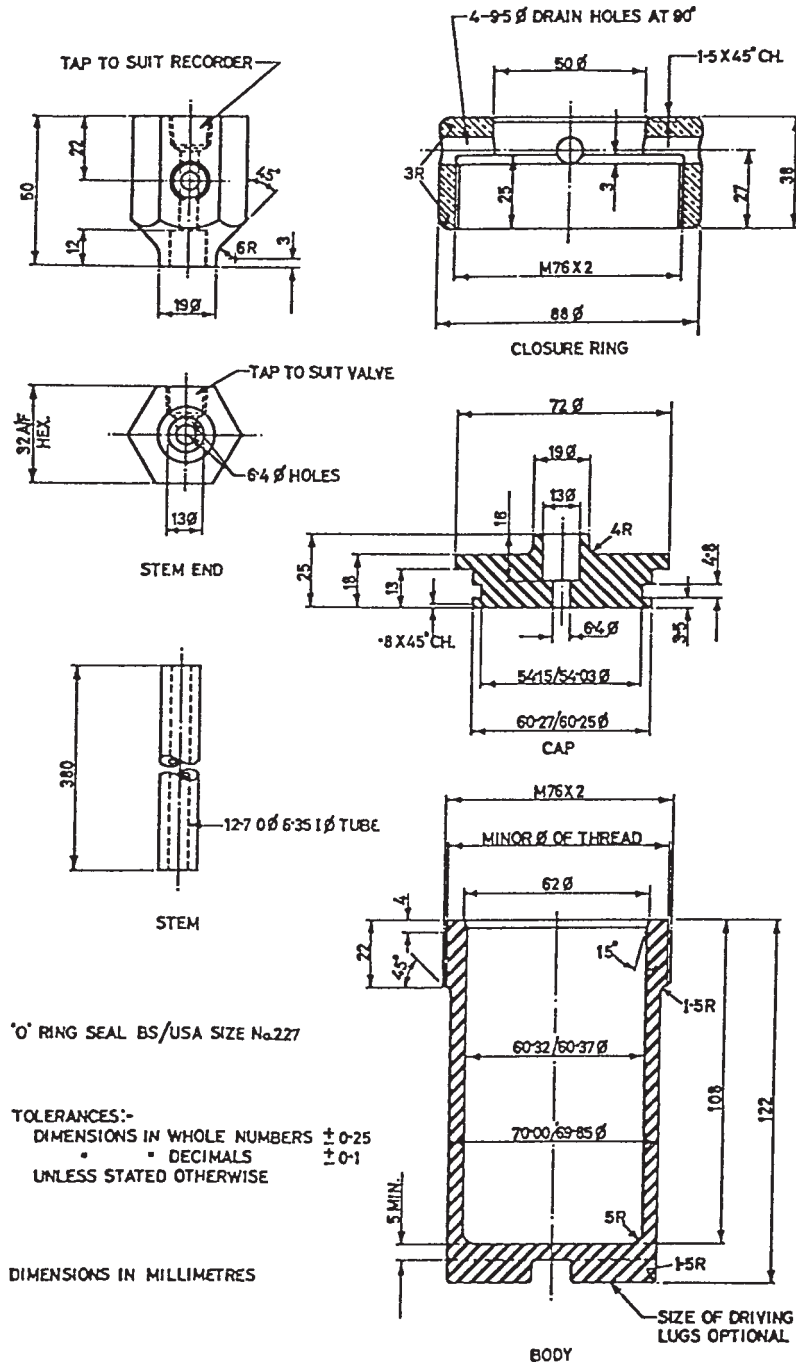

FIG. A1.4 Details of Oxidation Vessel

A1.3.2 *Pressure Measurement System*, consisting of electronic pressure transducers, power source, mounting equipment and connecting cables. The rotary transducer couplings can be mounted directly on the vessel stem in place of the standard mechanical pressure recorders. The pressure transducer shall have a span of 0 to 1400 kPa (or 0 to 200 psi or 0 to 14 bar). The accuracy should be valid over a wide compensated temperature range. The output signal from the transducer can be channeled into a datalogger, microprocessor based recorder, or a computer for data acquisition. The data acquisition package should be capable of logging pressure data vessel time. The overall system accuracy of the data should be within 2.5 % of the total scale.

A1.4 *Oxidation Bath*, equipped with an efficient stirrer and with a suitable device from holding and rotating the vessel axially at an angle of 30° at 100 ± 5 rpm while submerged in oil to a point at least 25 mm (1 in.) below the level of the bath liquid.

A1.4.1 At bath at least 230 mm (9 in.) deep, filled with 30 L (8 gal) of heavy bath oil per vessel, has the proper heat capacity. Silicone oil, it shall be necessary to house the oil bath under a fume hood to contain any oil vapor generated.

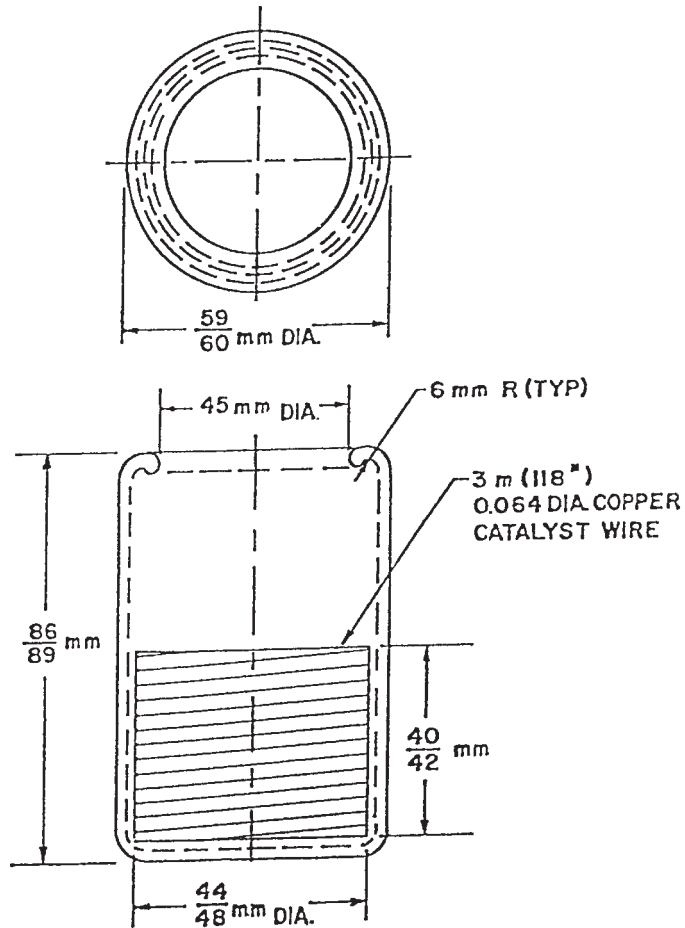
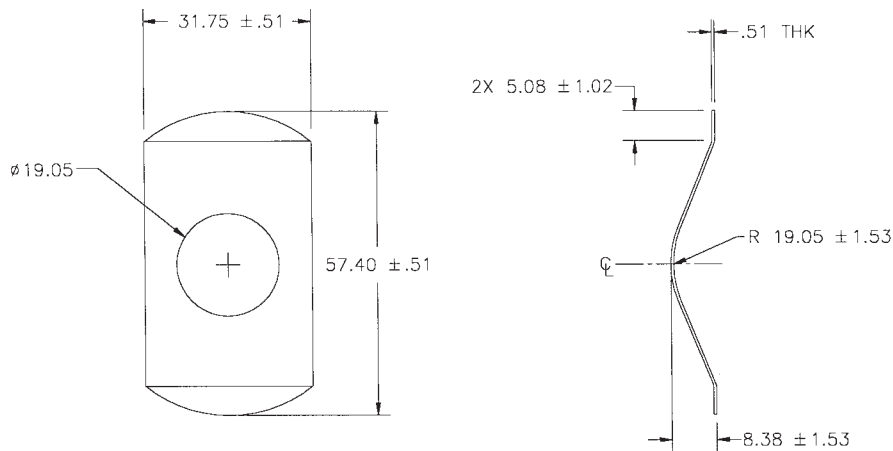

FIG. A1.5 Borosilicate Glass Sample Container



All dimensions are in millimeters  
Unless otherwise specified tolerance is  $\pm .13$

FIG. A1.6 Hold-down Spring

A1.4.2 Provide thermal regulation to maintain the bath within  $0.1^{\circ}\text{C}$  of the test temperature. There should be sufficient, immediately available heat to bring the bath to operating temperature within 15 min after the vessels have been inserted.

A1.5 *Thermometer*, IP 37C sludge test thermometer having a range from  $144$  to  $156^{\circ}\text{C}$  graduated in  $0.2^{\circ}\text{C}$  intervals or other temperature measuring device, having an accuracy of  $0.1^{\circ}\text{C}$ .

A1.6 *Gage*, for pressurizing vessel to  $620$  kPa ( $90$  psi) graduated in  $1.5$  kPa ( $0.2$  psi) increments.<sup>15</sup>

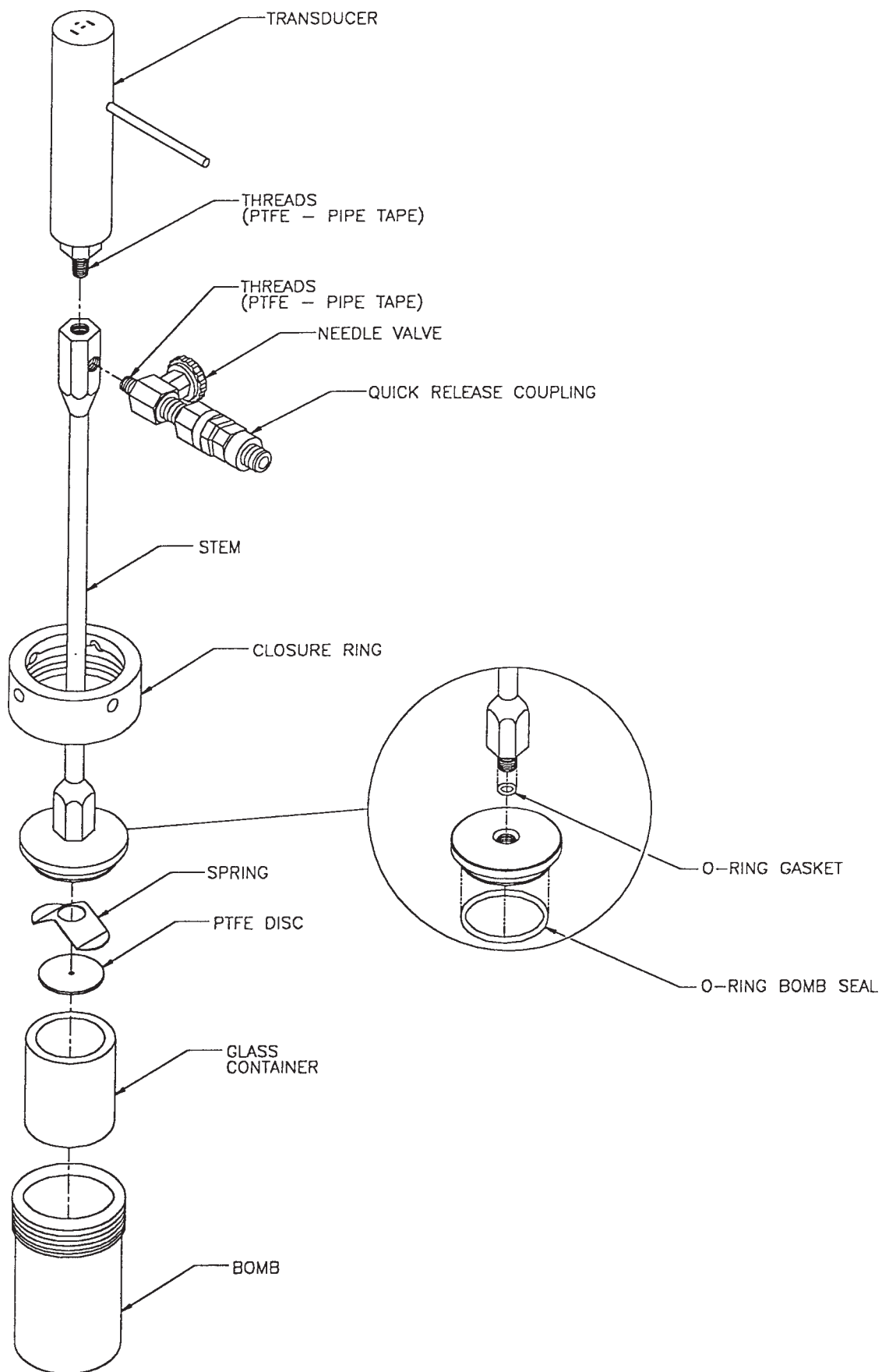

FIG. A1.7 Oxidation Vessel Assembly

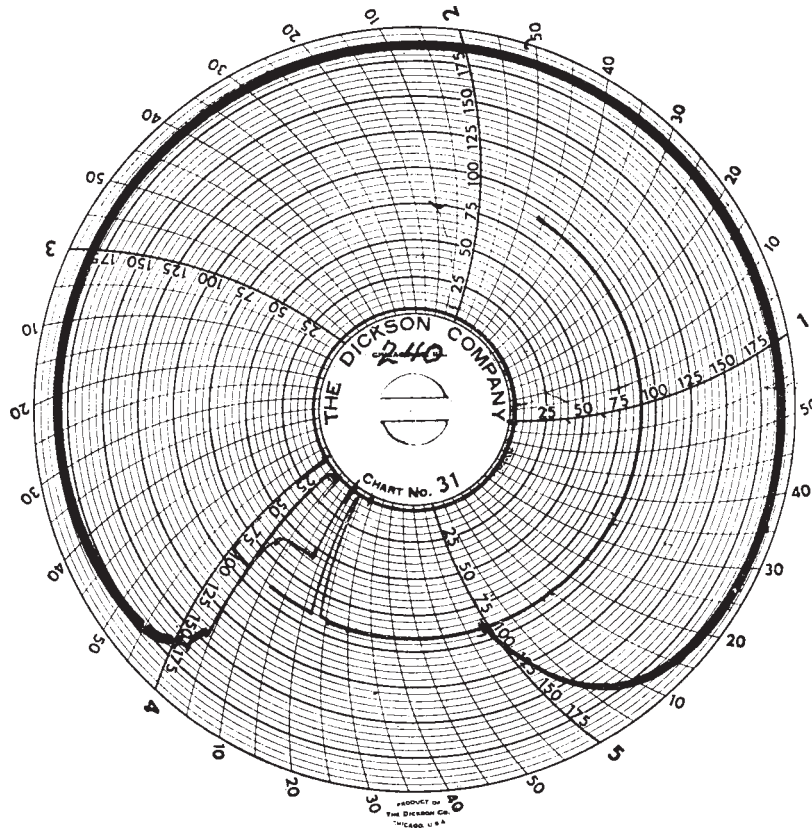

FIG. A1.8 Chart of Recording Pressure Gage (Actual Size = 4½ in.)

ASTM International takes no position respecting the validity of any patent rights asserted in connection with any item mentioned in this standard. Users of this standard are expressly advised that determination of the validity of any such patent rights, and the risk of infringement of such rights, are entirely their own responsibility.

This standard is subject to revision at any time by the responsible technical committee and must be reviewed every five years and if not revised, either reapproved or withdrawn. Your comments are invited either for revision of this standard or for additional standards and should be addressed to ASTM International Headquarters. Your comments will receive careful consideration at a meeting of the responsible technical committee, which you may attend. If you feel that your comments have not received a fair hearing you should make your views known to the ASTM Committee on Standards, at the address shown below.

This standard is copyrighted by ASTM International, 100 Barr Harbor Drive, PO Box C700, West Conshohocken, PA 19428-2959, United States. Individual reprints (single or multiple copies) of this standard may be obtained by contacting ASTM at the above address or at 610-832-9585 (phone), 610-832-9555 (fax), or service@astm.org (e-mail); or through the ASTM website (www.astm.org).