



Standard Test Method for Distillation of Crude Petroleum (15-Theoretical Plate Column)¹

This standard is issued under the fixed designation D 2892; the number immediately following the designation indicates the year of original adoption or, in the case of revision, the year of last revision. A number in parentheses indicates the year of last reapproval. A superscript epsilon (ϵ) indicates an editorial change since the last revision or reapproval.

1. Scope

1.1 This test method covers the procedure for the distillation of stabilized crude petroleum² to a final cut temperature of 400°C AET (Atmospheric Equivalent Temperature). The test method employs a fractionating column having an efficiency of 14 to 18 theoretical plates operated at a reflux ratio of 5:1. Performance criteria for the necessary equipment is specified. Some typical examples of acceptable apparatus are presented in schematic form. This test method offers a compromise between efficiency and time in order to facilitate the comparison of distillation data between laboratories.

1.2 The test method details procedures for the production of a liquified gas, distillate fractions, and residuum of standardized quality on which analytical data can be obtained, and the determination of yields of the above fractions by both mass and volume. From the above information, a graph of temperature versus mass % distilled can be produced. This distillation curve corresponds to a laboratory technique, which is defined at 15/5 (15 theoretical plate column, 5:1 reflux ratio) or TBP (true boiling point).

1.3 This test method can also be applied to any petroleum mixture except liquified petroleum gases, very light naphthas, and fractions having initial boiling points above 400°C.

1.4 This test method contains the following Annexes:

1.4.1 Annex A1—Test Method for the Determination of the Efficiency of a Distillation Column,

1.4.2 Annex A2—Test Method for the Determination of the Dynamic Holdup of a Distillation Column,

1.4.3 Annex A3—Test Method for the Determination of the Heat Loss in a Distillation Column (Static Conditions),

1.4.4 Annex A4—Test Method for the Verification of Temperature Sensor Location,

1.4.5 Annex A5—Test Method for Determination of the Temperature Response Time,

1.4.6 Annex A6—Practice for the Calibration of Sensors,

1.4.7 Annex A7—Test Method for the Verification of Reflux Dividing Valves,

1.4.8 Appendix X1—Test Method for Dehydration of a

Sample of Wet Crude Oil,

1.4.9 Annex A8—Practice for Conversion of Observed Vapor Temperature to Atmospheric Equivalent Temperature (AET), and

1.4.10 Annex A9—Practice for Performance Check.

1.5 The values stated in SI units are to be regarded as standard. The values given in parentheses are provided for information purposes only.

1.6 *This standard does not purport to address all of the safety concerns, if any, associated with its use. It is the responsibility of the user of this standard to establish appropriate safety and health practices and determine the applicability of regulatory limitations prior to use.* For specific precautionary notes, see Section 9.

2. Referenced Documents

2.1 *ASTM Standards:*

D 941 Test Method for Density and Relative Density (Specific Gravity) of Liquids by Lipkin Bicapillary Pycnometer³

D 1217 Test Method for Density and Relative Density (Specific Gravity) of Liquids by Bingham Pycnometer⁴

D 1298 Test Method for Density, Relative Density (Specific Gravity), or API Gravity of Crude Petroleum and Liquid Petroleum Products by Hydrometer Method⁴

D 2427 Test Method for Determination of C₂ through C₅ Hydrocarbons in Gasolines by Gas Chromatography⁴

D 4006 Test Method for Water in Crude Oil by Distillation⁵

D 4052 Test Method for Density and Relative Density of Liquids by Digital Density Meter⁵

D 4057 Practice for Manual Sampling of Petroleum and Petroleum Products⁵

D 4177 Practice for Automatic Sampling of Petroleum and Petroleum Products⁵

3. Terminology

3.1 *Definitions:*

3.1.1 *adiabaticity*—the condition in which there is no significant gain or loss of heat throughout the length of the column.

¹ This test method is under the jurisdiction of ASTM Committee D-2 on Petroleum Products and Lubricants and is the direct responsibility of Subcommittee D02.08 on Volatility.

Current edition approved Nov. 10, 1999. Published January 2000. Originally published as D 2892 – 70 T. Last previous edition D 2892 – 99.

² Defined as having a Reid vapor pressure less than 82.7 kPa (12 psi).

³ Discontinued; see 1993 *Annual Book of ASTM Standards*, Vol 05.01.

⁴ *Annual Book of ASTM Standards*, Vol 05.01.

⁵ *Annual Book of ASTM Standards*, Vol 05.02.

3.1.1.1 *Discussion*—When distilling a mixture of compounds as is the case of crude petroleum, there will be a normal increase in reflux ratio down the column. In the case where heat losses occur in the column, the internal reflux is abnormally greater than the reflux in the head. The opposite is true when the column gains heat, as with an overheated mantle.

3.1.2 *boilup rate*—the quantity of vapor entering the column per unit of time.

3.1.2.1 *Discussion*—It is expressed in millilitres of liquid per hour for a given column or in millilitres per hour per square centimetre of cross-sectional area for comparative purposes. In the latter case, it refers to the test mixture of *n*-heptane and methylcyclohexane in the efficiency evaluation (see Annex A1) and is measured at the bottom of the column. The maximum boilup of the *n*-heptane-methylcyclohexane test mixture is that which the column can handle under stable conditions without flooding. In routine adiabatic operation, the boilup rate can be estimated roughly from the takeoff rate multiplied by the reflux ratio plus one.

3.1.3 *debutanization of crude petroleum*—the removal of the light hydrocarbons up to and including *n*-butane, and retention of the heavier hydrocarbons.

3.1.3.1 *Discussion*—In practice, a crude petroleum is regarded as debutanized if the light hydrocarbon cut collected in the cold trap contains more than 95 % of the C₂ to C₄ hydrocarbons and less than 5 % of the C₅ hydrocarbons initially present in the sample.

3.1.4 *distillation pressure*—the pressure measured as close as possible to the point where the vapor temperature is taken,

normally at the top of the condenser.

3.1.5 *distillation temperature*—the temperature of the saturated vapor measured in the head just above the fractionating column.

3.1.5.1 *Discussion*—It is also known as the head temperature or the vapor temperature.

3.1.6 *dynamic hold-up*—the quantity of liquid held up in the column under normal operating conditions.

3.1.6.1 *Discussion*—It is expressed as a percentage of the packed volume for packed columns so that the data can be compared. For real plate columns, it is expressed in millilitres per plate. The data can only be compared with others of the same diameter because of different tray spacing. Data for packed columns cannot be compared with those of real plate columns except in absolute units of milliliters per theoretical plate (see Table 1). Dynamic hold-up increases with increasing distillation rate up to the flood point and varies from one kind of fractionator to another.

3.1.7 *flood point*—the point at which the velocity of the upflowing vapors obstructs the downcoming reflux and the column suddenly loads with liquid.

3.1.7.1 *Discussion*—Under these conditions no vapor can reach the head and the heat to the distillation flask must be reduced to establish normal operations again. The flood point is normally determined during the efficiency evaluation of a column using the *n*-heptane-methylcyclohexane test mixture (see Annex A1).

3.1.8 *internal reflux*—the liquid normally running down inside the column.

TABLE 1 Data for *n*-Heptane-Methylcyclohexane Test Mixture at 75 % of Maximum Boilup and 101.3 kPa (760 mm Hg)

	Propak ^{A,B,C,D,E}			Helipak ^{F,G,H}		Perforated Plates ^{E,I,J}		Wire Mesh ^{E,K}	
Column diameter, mm	25	50	70	25	50	25	50	25	50
Packing size, mm	4	6	6	No. 2917	No. 2918	NA ^L	NA ^L	NA ^L	NA ^L
Boilup, mL/h × cm ²	650	670	675	300	350	640	660	810	1050
Dynamic holdup									
% of packed volume	17	15.3	17.0	15	14.3	NA ^L	NA ^L	8.0	10.0
mL/theoretical plate	3.2	16	39	1.6	8.7	2.8	12.3	2.0	12.9
Pressure drop									
kPa/m	1.2	1.05	0.94	1.53	1.41	NA ^L	NA ^L	0.97	0.75
mm Hg/m	9.0	7.9	7.1	11.5	10.6	NA ^L	NA ^L	7.3	5.6
kPa/theoretical plate	0.045	0.056	0.06	0.03	0.045	0.15	0.16	0.05	0.05
mm Hg/theoretical plate	0.34	0.42	0.43	0.24	0.34	1.1	1.2	0.35	0.37
HETP, mm (% of real plates)	38	53	61	21	32	(60 %)	(65 %)	48	66
For 15-plate Towers									
Packed height, cm (plates)	57	80	91	31.5	48	(25)	(23)	72	99
Packed volume, mL	280	1570	3460	155	917	NA ^L	NA ^L	353	1940
Dynamic holdup, mL	47	240	590	23	131	42	184	28	194
Pressure drop									
kPa	0.68	0.84	0.86	0.48	0.68	2.2	2.4	0.70	0.73
mm Hg	5.1	6.3	6.5	3.6	5.1	16.5	18.0	5.3	5.5
Charge volume, L									
Min (4 % Holdup)	1.2	6.0	15	0.575	3.3	1.0	4.6	0.7	4.9
Max (1 % Holdup)	4.8	24.0	60	2.3	13.0	4.2	10.4	2.8	19.4

^ACooke, G. M. and Jameson, B. G. *Analytical Chemistry*, Vol 27, 1955, p. 1798.

^BStruck, R. T. and Kinner, C. R. *Industrial and Engineering Chemistry*, Vol 42, 1950, p. 77.

^CCannon, M. R. *Industrial and Engineering Chemistry*, Vol 41, No. 9, 1949, p. 1953.

^DBulletin 23, Scientific Development Co. P.O. Box 795, State College, PA 16801.

^ECooke, G. M. *Analytical Chemistry*, Vol 39, 1967, p. 286.

^FBulletin of Podbielniak Div. of Reliance Glass Works, P.O. Box 825, Bensenville, IL 60106.

^GFeldman, J., et al, *Industrial and Engineering Chemistry*, Vol 45, January 1953, p. 214.

^HHelipak Performance Characteristics, Begemear, C. R. and Turkal, P. J. (Laboratory Report of Podbielniak Inc.), 1950.

^IUmholtz, C. L. and Van Winkle, M. *Petroleum Refiner*, Vol 34, 1955, p. 114 for NH:MCH.

Pressure Drop Calculated from data obtained on *o*- and *m*-xylene binary.

^JOldershaw, C. F. *Industrial and Engineering Chemistry*, Vol 13, 1941, p. 265.

^KBragg, L. B. *Industrial and Engineering Chemistry*, Vol 49, 1957, p. 1062.

^LNA = not applicable.

3.1.8.1 *Discussion*—In the case of an adiabatic column when distilling a pure compound, the internal reflux is constant from top to bottom and is equal to the reflux at the reflux divider. When distilling crude petroleum, the fractionation occurring in the dynamic holdup will cause a temperature gradient to be established with attendant greater amount of internal reflux at the bottom of the column.

3.1.9 *pressure drop*—the difference between the pressure measured in the condenser and the pressure measured in the distillation flask.

3.1.9.1 *Discussion*—It is expressed in kilopascals (mm Hg) per metre of packed height for packed columns, or kilopascals (mm Hg) overall for real plate columns. It is higher for aromatics than for paraffins, and for higher molecular weights than for lighter molecules, at a given boilup rate.

3.1.10 *reflux ratio, R*—the ratio of reflux to distillate.

3.1.10.1 *Discussion*—The vapor reaching the top of the column is totally condensed and the resulting liquid is divided into two parts. One part L (reflux), is returned to the column and the other part, D (distillate), is withdrawn as product. The reflux ratio ($R = L/D$), can vary from zero at total takeoff ($L = 0$) to infinity at total reflux ($D = 0$).

3.1.11 *static hold-up or wetting*—the quantity of liquid retained in the column after draining at the end of a distillation.

3.1.11.1 *Discussion*—It is characteristic of the packing or the design of the plates, and depends on the composition of the material in the column at the final cut point and on the final temperature.

3.1.12 *takeoff rate*—the rate of product takeoff from the reflux divider expressed in millilitres per hour.

3.1.13 *theoretical plate*—the section of a column required to achieve thermodynamic equilibrium between a liquid and its vapor.

3.1.13.1 *Discussion*—The height equivalent to one theoretical plate (HETP) for packed columns is expressed in millimetres. In the case of real plate columns, the efficiency is expressed as the percentage of one theoretical plate that is achieved on one real plate.

4. Summary of Test Method

4.1 A weighed sample of 1 to 30 L of stabilized crude petroleum is distilled to a maximum temperature of 400°C AET in a fractionating column having an efficiency at total reflux of at least 14, but not greater than, 18 theoretical plates.

4.2 A reflux ratio of 5:1 is maintained at all operating pressures, except that at the lowest operating pressures between 0.674 and 0.27 kPa (5 and 2 mmHg), a reflux ratio of 2:1 is optional. In cooperative testing or in cases of dispute, the stages of low pressure, the reflux ratios, and the temperatures of cut points must be mutually agreed upon by the interested parties prior to beginning the distillation.

4.3 Observations of temperature, pressure, and other variables are recorded at intervals and at the end of each cut or fraction.

4.4 The mass and density of each cut or fraction are obtained. Distillation yields by mass are calculated from the mass of all fractions, including liquified gas cut and the residue. Distillation yields by volume of all fractions and the residue at 15°C are calculated from mass and density.

4.5 From these data the TBP curves in mass or volume %, or both, versus AET are drawn.

5. Significance and Use

5.1 This test method is one of a number of tests conducted on a crude oil to determine its value. It provides an estimate of the yields of fractions of various boiling ranges and is therefore valuable in technical discussions of a commercial nature.

5.2 This test method corresponds to the standard laboratory distillation efficiency referred to as 15/5. The fractions produced can be analyzed as produced or combined to produce samples for analytical studies, engineering and product quality evaluations. The preparation and evaluation of such blends is not part of this test method.

5.3 This test method can be used as an analytical tool for examination of other petroleum mixtures with the exception of LPG, very light naphthas, and mixtures with initial boiling points above 400°C.

6. Apparatus

6.1 *Distillation at Atmospheric Pressure*—All components must conform to the requirements specified below. Automatic devices can be employed provided they meet the same requirements. A typical apparatus is illustrated in Fig. 1.

6.1.1 *Distillation Flask*—The distillation flask shall be of a size that is at least 50 % larger than the volume of the charge. The size of the charge, between 1.0 and 30 L, is determined by the holdup characteristics of the fractionating column, as shown in Table 1 and described in Annex A2. The distillation flask shall have at least one sidearm.

6.1.1.1 The sidearm is used as a thermowell. It shall terminate about 5 mm from the bottom of the flask to ensure its immersion at the end of the distillation. When a second sidearm is present, it can be used for pressure drop detection with a nitrogen bleed or for mechanical stirring, or both.

6.1.1.2 If a magnetic stirrer is used with a spherical flask, the flask shall have a slightly flattened or concave area at the bottom on which the magnetic stirrer can rotate without grinding the glass. In this case, termination of the thermowell shall be off center 40 ± 5 mm to avoid the magnetic stirring bar. Boiling chips can be used as an alternative to a stirrer.

6.1.1.3 **Warning**—While the advantage of visibility in glass distillation flasks is desirable, flasks of glass may become hazardous the larger the charge they contain. For this reason, glass flasks of a volume greater than 10 L are not recommended.

6.1.2 *Heating System*—Heating of the flask shall be provided in such a way that full boilup can be maintained at a steady rate at all pressure levels. An electric heating mantle covering the lower half of the flask and having one third of the heat in an element located in the bottom central area and the remaining two thirds in the rest of the hemisphere is recommended. While proportioning controllers are preferred, heat input can be manually adjusted by use of a variable auto transformer on each circuit, the smaller heater being automatically controlled by an instrument sensing the pressure drop of the column as registered in a differential pressure instrument or alternatively by direct measurement of distillation rate.

6.1.2.1 Minimum wattage required to provide full boilup of

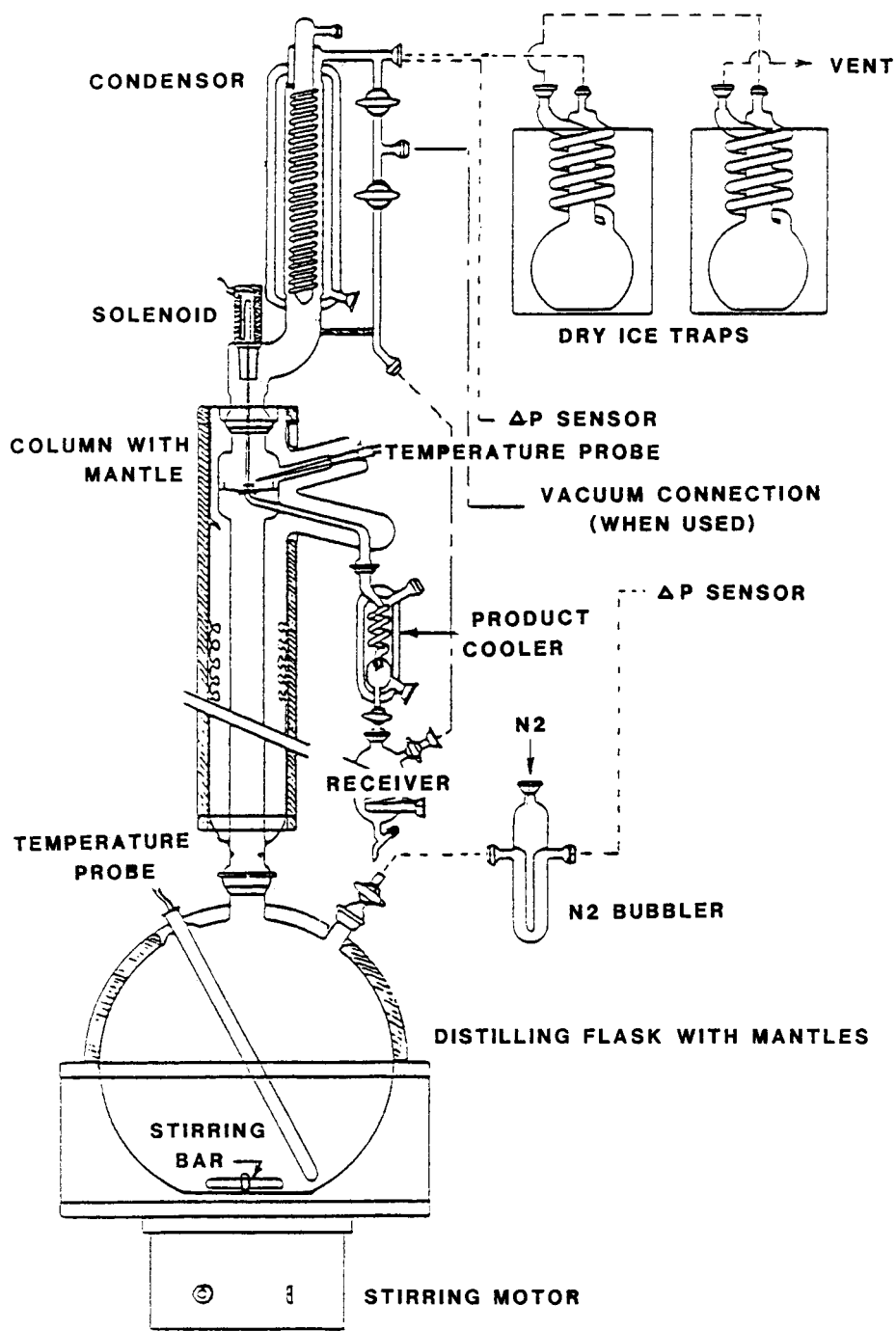

FIG. 1 Apparatus

crude petroleum is approximately 0.125 W/mL of charge. Twice this amount is recommended for quick heat-up.

6.1.2.2 The heat density in the flask heaters is approximately equal to 0.5 to 0.6 W/cm². This requires the use of nickel reinforced quartz fabric to ensure a reasonable service life.

6.1.2.3 Immersion heaters can be employed in a similar way and have the advantage of faster response, but they are more fragile and require a specially designed flask to ensure that the heating elements remain immersed at the end of the run. When used, their heat density should be approximately equal to 4 W/cm².

6.1.2.4 The upper half of the flask shall be covered with a mantle to avoid unnecessary heat losses from the upper surface and shall have an electric heater supplying about 0.25 W/cm² at full-rated voltage.

6.1.3 *Fractionating Column*—The fractionating column must contain either particulate packing or real plates similar to those whose performance characteristics are summarized in Table 1 and meet the specifications stated in 6.1.3.1 through 6.1.3.4. Table 2 lists current North American suppliers of suitable packings.

6.1.3.1 The internal diameter shall be between 25 and 70 mm.

TABLE 2 North American Sources of Commercially Available Packing Materials

Name	Size	Source
Propak	6 by 6 mm	Scientific Development Co. P.O. Box 795 State College, PA 16801
Helipak	2.5 by 4 mm	Reliance Glass Works Inc. P.O. Box 825 Bensenville, IL 60106
Perforated plates	25 and 50 mm	Reliance Glass Works Inc. P.O. Box 825 Bensenville, IL 60106 W.A. Sales Inc. 419 Harvester Ct. Wheeling, IL 60090
Knitted wire mesh- Goodloe multiknit		Pegasus Industrial Specialties Ltd. P.O. Box 319 Agincourt, Ontario MIS 3B9 Canada Packed Column Co. 970 New Durham Rd. Edison, NJ 08817

6.1.3.2 The efficiency shall be between 14 and 18 theoretical plates at total reflux when measured by the procedure described in Annex A1.

6.1.3.3 The fractionating column shall be comprised of a integral glass column and reflux divider totally enclosed in a highly reflective vacuum jacket having a permanent vacuum of less than 0.1 mPa ($\sim 10^{-6}$ mm Hg). It shall be essentially adiabatic when tested in accordance with Annex A3.

6.1.3.4 The column shall be enclosed in a heat insulating system, such as a glass-fabric mantle, capable of maintaining the temperature of the outer wall of the glass vacuum jacket equal to that of the internal vapor temperature. To verify this, the vacuum jacket shall have a temperature sensor, such as a thermocouple, soldered to about 6 cm² of thin copper or brass sheet and fastened to the outer wall of the glass jacket at a level just below the reflux divider.

NOTE 1—For certain types of columns there is no significant difference in yields and fraction qualities between an uncompensated and a heat compensated column. In such a case, by mutual agreement between parties concerned, the application of a heated insulating system can be omitted.

6.1.3.5 The adjustable reflux divider shall be located about one column diameter above the top of the packing or topmost plate. It must be capable of dividing the condensate with an accuracy of better than 90 % between the column and the takeoff line over a range of rates between 25 and 95 % of the maximum boilup rate of the column when determined in accordance with Annex A7.

6.1.4 *Condenser*—The condenser shall have sufficient capacity to condense essentially all the C₄ and C₅ vapors from the crude at the specified rate, using a coolant temperature of -20°C .

6.1.5 *Cold Traps*—Two efficient traps of adequate capacity cooled by dry ice and alcohol mixture shall be connected in series to the vent line of the condenser when light hydrocarbons are present, as at the beginning of the distillation. For vacuum distillation, a Dewar style trap also cooled by dry ice is used to protect the vacuum gage from vapors.

6.1.6 *Gas Collector*—If uncondensed gas is to be measured, a gas meter can be connected to the outlet of the cold trap but

with a calcium chloride drying tube between them to keep moisture from collecting in the traps. When analysis of the gas sample is required, the gas can be collected in an empty plastic balloon of suitable size either in place of the meter or following it. The volume of its contents can be determined by calculation from the rise in pressure after expanding the sample into an evacuated vessel of known volume.

6.1.7 *Fraction Collector*—This part of the apparatus permits the collection of the distillate without interruption during withdrawal of product from the receiver under atmospheric or reduced pressure. It also permits removal of product from the vacuum system, without disturbing conditions in the column.

6.1.8 *Product Receivers*—The receivers shall be of suitable size for the quantity of crude petroleum being distilled. The recommended capacity is from 100 to 500 mL. They shall be calibrated and graduated to permit reading to the nearest 1 %.

6.2 *Distillation Under Reduced Pressure*—In addition to the apparatus listed in 6.1, the apparatus for distillation under reduced pressure shall include the following:

6.2.1 *Vacuum Pump*—The vacuum system shall be capable of maintaining smooth pressure operation at all pressure levels. It shall have the capacity to draw down the pressure in the receiver(s) from atmospheric to 0.25 kPa (2 mm Hg) in less than 30 s so as to avoid disturbance of the system during emptying of receivers under vacuum. Alternatively, a separate pump can be employed for this purpose.

6.2.2 *Vacuum Gage*—The point of connection of the vacuum gage to the system shall be as close as practical to the reflux dividing head. The connecting tubing shall be of sufficient diameter to ensure that no measurable pressure drop occurs in the line. In no case shall the vacuum gage connection be near the vacuum pump.

6.2.2.1 All gages shall be carefully protected from condensable vapors, especially water vapor, by a cold trap maintained at the temperature of dry ice.

6.2.3 *Pressure Regulator*—The regulator shall maintain the pressure in the system essentially constant at all operating pressures. Automatic regulation can be achieved by a device that regulates the demand on the vacuum source. A satisfactory device is a solenoid valve positioned between the vacuum source and a surge tank of at least 10-L capacity. Alternatively, a manual bleed valve can be maintained by a trained operator with a minimum of attention.

6.3 *Sensing and Recording Apparatus:*

6.3.1 *Temperature Sensors*—Only temperature measurement systems meeting the requirements of 6.3.1.1 and 6.3.1.2 shall be used.

6.3.1.1 The vapor temperature sensor can be a platinum resistance thermometer, a Type J thermocouple with the junction head fused to the lower tip of the thermowell, or any other device that meets the requirements in this paragraph and 6.3.1.2. The tip of the sensor shall be located above the top of the packing or the topmost glass plate and in close proximity to the reflux divider but not in contact with the liquid reflux. The location of the vapor temperature sensor shall be proved by the method described in Annex A4. The sensor shall have a cooling time of not more than 175 s, as described in Annex A5.

6.3.1.2 The vapor temperature measuring device shall have

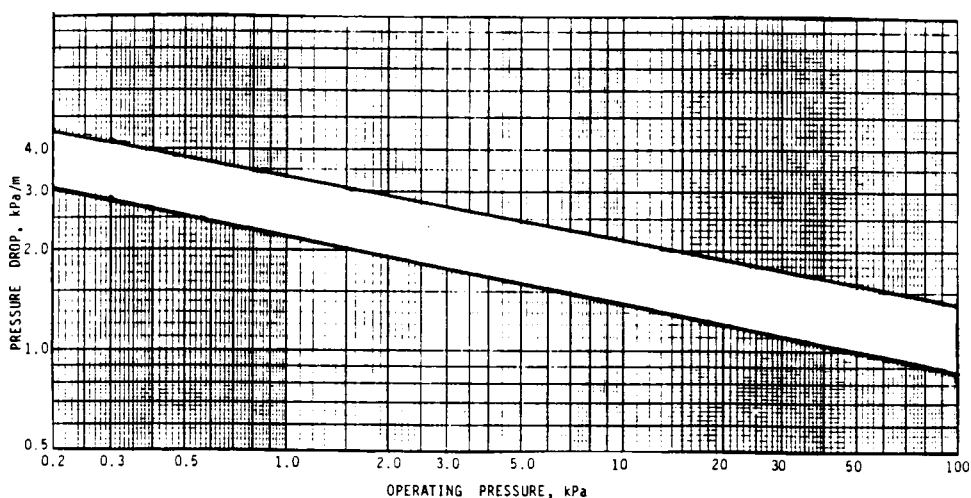

FIG. 2 Approximate Pressure Drop-Fractionators Using Propak

an accuracy of 0.5°C or better and be measured with a resolution of 0.1°C or better. The liquid temperature measuring device shall have an accuracy of 1.0°C or better and be measured with a resolution of 0.5°C or better. Temperatures are recorded either manually or automatically.

6.3.1.3 Temperature sensors shall be calibrated as described in Annex A6. Alternatively certified sensors may be used, provided the calibration of the sensor and its associated recording instrument can be traced back to a primary temperature standard. Temperature sensors are calibrated over the full range of temperature (0 to 400°C) at the time of first use of the sensor in combination with its associated instrument. Recalibrate when either the sensor or the instrument is repaired or serviced. Verification of the calibration of the temperature sensors is to be made on a regular basis. For vapor temperature sensors, verification at least once a month is recommended and for liquid temperature sensors once every six months. Verification of the calibration of the sensors can be accomplished potentiometrically by the use of standard precision resistance or by distilling a pure compound with accurately known boiling point.

6.3.2 *Vacuum Gage*—A nontilting McLeod gage or a mercury manometer are primary standards and can be used without calibration when properly used and maintained. A mercury manometer, however, will only be of satisfactory accuracy down to a pressure of about 1 kPa and then only when read with a good cathetometer (an instrument based on a telescope mounted on a vernier scale to determine levels very accurately). Alternatively, a tensimeter or certified electronic sensors may be used, provided the calibration of the sensor and its associated recording instrument can be traced back to a primary pressure standard. Sensors of the diaphragm type have been found satisfactory. Vacuum gages based on hot wires, radiation, or electrical conductivity detectors are not recommended.

6.3.2.1 The gage for measuring subatmospheric pressures shall have an accuracy at least equal to that stated below:

Distillation Pressure		Accuracy	
kPa	mmHg	kPa	mmHg
100-13.3	760 to 100	0.13	1.0

13.3-1.33	99 to 10	0.013	0.1
1.33-0.266	9 to 2	0.006	0.06

6.3.2.2 Noncertified gages shall be calibrated from a nontilting McLeod gage or a secondary electronic standard traceable to a primary standard. A basic calibration procedure is described in Annex A6. Recalibrate when either the sensor or the instrument is repaired or serviced. Verification of the calibration of the electronic pressure sensors is to be made on a regular basis. A frequency of at least once a month is recommended. Verification of the calibration of the sensors can be accomplished using the procedures described in Annex A6 or against a certified reference system.

6.3.3 *Boilup Rate*—The boilup rate is normally controlled by sensing the pressure drop in the column. The pressure drop during operation is measured by means of a manometer or pressure transducer connected between the flask and the condenser. Prevention of condensation in the connecting tube can be accomplished by injecting a very small flow of nitrogen (8 cm³/s) between the pressure drop sensor manometer and the flask (see Fig. 1) or by placing a small water cooled condenser between the flask and the pressure drop sensor. Alternatively, the boilup rate can be controlled from the measurement of take off rate.

7. Sampling

7.1 Obtain a sample for distillation in accordance with instructions given in Practice D 4057 or D 4177. The sample must be received in a sealed container and show no evidence of leakage.

7.2 Cool the sample to between 0 and 5°C by placing it in a refrigerator for several hours (preferably overnight) before opening.

7.3 If the sample appears waxy or too viscous, raise the temperature to 5°C above its pour point.

7.4 Agitate the sample by whatever means are appropriate to its size to ensure that it is well-mixed.

7.5 Determine the water content of the sample by Test Method D 4006 or any other suitable method. If the water content exceeds 0.3 % volume, the sample shall be dehydrated

prior to fractional distillation. A suitable practice for dehydration of wet crude oil samples is described in Appendix X1.

NOTE 2—Attempts to distill wet crude oil samples in glass columns might result in breakage of the glassware, which poses a potential fire hazard. Moreover, the presence of water will effect the accuracy of distillation yield in the naphtha region. These effects are more pronounced for heavy crude oils, containing low amounts of hydrocarbons boiling below 100°C, than for light crudes where there is usually sufficient hydrocarbon vapor generated to form an azeotrope and drive the water vapors through the column without problems.

8. Preparation of Apparatus

8.1 Clean and dry the distillation column and all the ancillary glass apparatus before the distillation begins.

8.2 Ensure that the system is leak-free and all heaters, control devices, and instruments are on and in working order. A clock or other timing device should be ready for use.

9. Procedure

9.1 Charging:

9.1.1 The charge size shall be such that the dynamic hold-up as determined in accordance with Annex A2 is between 1 and 4 % of the charge when operating at 75 % of maximum boilup (see Table 1). Chill the flask to a temperature not lower than 0°C.

9.1.2 Insert the stirring device or place some pieces of glass or porcelain into the flask to control bumping.

9.1.3 Determine the density of the sample by Test Method D 941, D 1217, or D 1298.

9.1.4 Calculate to within ± 5 % the mass of crude petroleum corresponding to the desired volume of the charge. Weigh to the nearest 1 % this quantity of sample into the flask.

9.1.5 Attach the flask to the column and connect the pressure drop measuring device. Install the heating system, stirrer, and support device. (**Warning**—Poisonous H₂S gas is frequently evolved from crude oil and precautions must be taken either to absorb the gas that passes through the cold trap or to vent it to a safe place.)

9.2 Debutanization:

9.2.1 For necessary apparatus refer to 6.1.5 and 6.1.6.

9.2.2 Begin circulation of refrigerant at a temperature no higher than -20°C in the condenser, distillate cooler, and receiver, if so equipped.

9.2.3 Record the barometric pressure at the beginning and periodically throughout the distillation.

9.2.4 Apply heat to the flask at such a rate that vapors reach the top of the column between 20 and 50 min after startup. Adjust heat input so as to achieve a pressure drop of less than 0.13 kPa/m (1.0 mm Hg/m) in packed columns or less than 0.065 kPa (0.5 mm Hg) in real plate columns. Program automated equipment in accordance with the above directions. Turn on the stirring device if used.

9.2.5 Allow the column to operate at total reflux until the vapor temperature reaches equilibrium but not longer than 15 min after the first drop of condensate appears in the reflux divider.

9.2.6 Record the vapor temperature as the initial vapor temperature.

9.2.7 Stop the circulation of the refrigerant and observe the vapor temperature. When the vapor temperature reaches 15°C,

start the circulation of refrigerant again.

9.2.8 If the vapor temperature drops below 15°C, continue refluxing for at least 15 min. Repeat 9.2.7. If the vapor temperature remains at 15°C or rises, continue with the atmospheric distillation. (**Warning**—The following three steps should not be done until after the first naphtha cut has been removed to ensure that all the light gases have been recovered.)

9.2.9 Remove and weigh the dry ice traps containing light hydrocarbon liquid after carefully wiping them dry.

9.2.10 Sample the contents of the first dry ice trap using a 10 to 50 mL pressure vessel evacuated to no lower than 26.6 kPa (200 mm Hg). Keep all containers at the temperature of dry ice to ensure no loss of volatiles. The first trap next to the condenser should contain all of the sample. If condensate is found in the second trap, sample both traps or else combine the contents before sampling.

9.2.11 Submit the trap sample and gas balloon, if used, for analysis by Test Method D 2427 to be reported on a fixed-gas free basis.

9.3 Distillation at Atmospheric Pressure:

9.3.1 Maintain a temperature below -20°C in the lines of the distillate cooler and receiver as well as in the condenser. Turn on the column mantle heat controller and maintain the column jacket temperature 0 to 5°C below the vapor temperature.

9.3.2 Regulate the heat input as necessary to establish and maintain a boilup rate approximately 75 % of maximum. Fig. 3 and Fig. 4 can be used as a guide for Propak. Rates for other sizes can be estimated by multiplying the boilup rate in Table 1 by the cross-sectional area of the column and dividing by the sum of the reflux ratio + 1.

9.3.3 Commence takeoff at a reflux ratio of 5:1 and total cycle time of not over 30 s nor less than 18 s.

9.3.4 Take off distillate in separate and consecutive fractions of suitable size. The recommended size of fraction is that

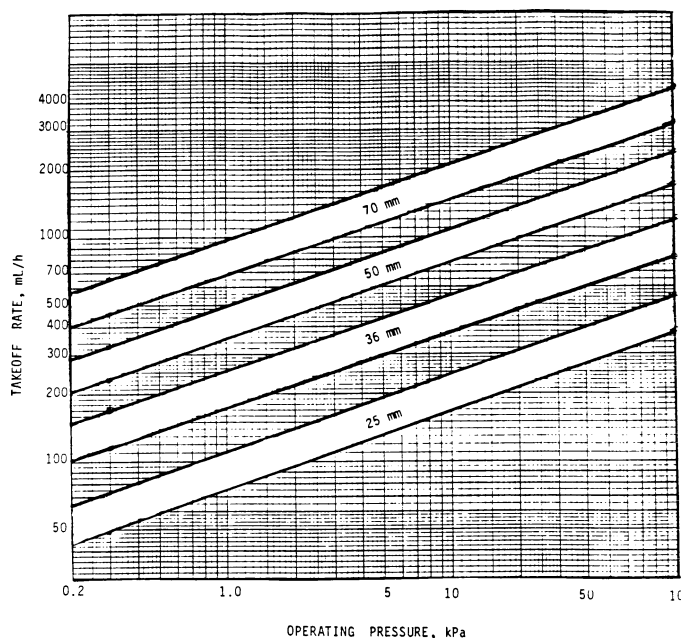

FIG. 3 Expected Takeoff Rates at 5:1 Reflux Ratio for Fractionators Using Propak

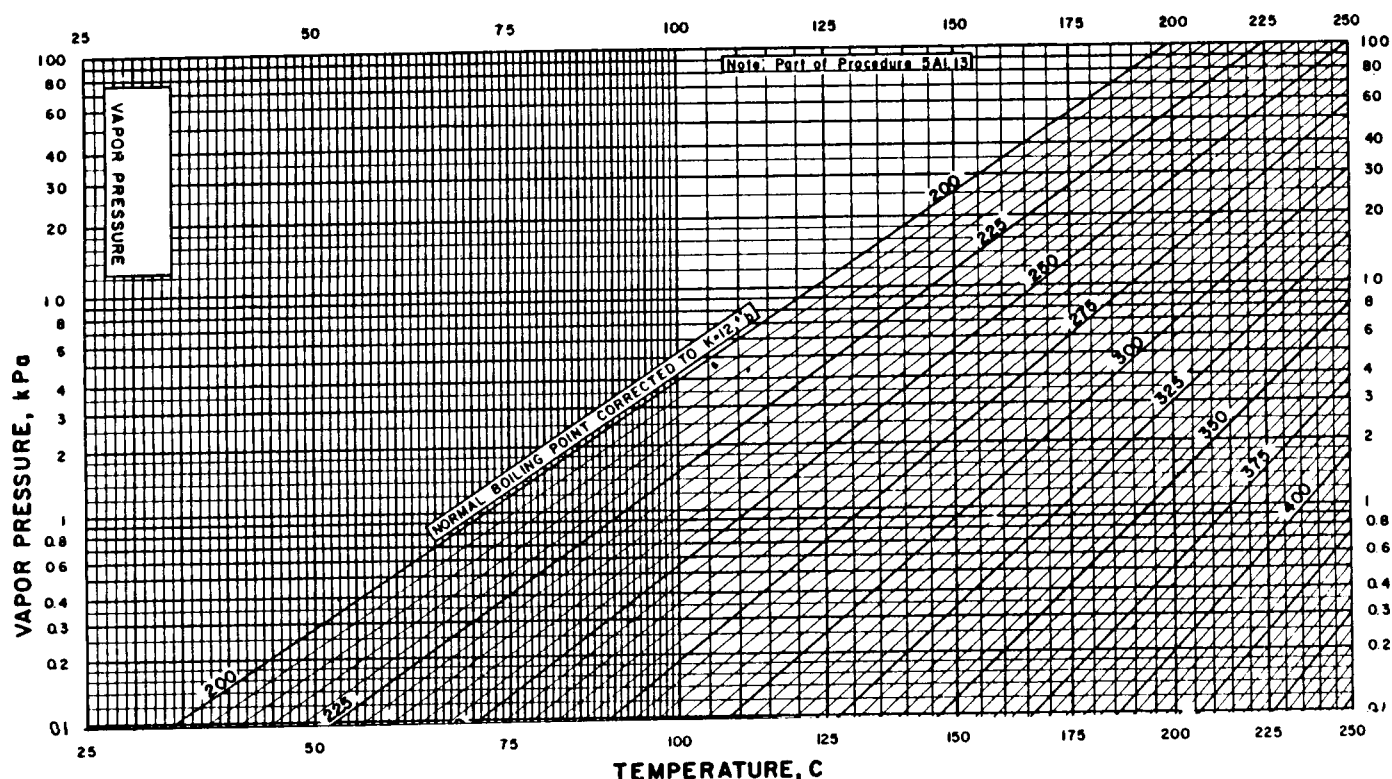

FIG. 4 Vapor Correction Chart

corresponding to 5 or 10°C in vapor temperature. Collect fractions boiling below 65°C in receivers cooled to 0°C or below. When the vapor temperature reaches 65°C, refrigerant in the condenser and related coolers can be discontinued and water at ambient temperature substituted.

9.3.5 At the end of each fraction and at each cut point, record the following observations:

- 9.3.5.1 Time in hours and minutes,
- 9.3.5.2 Volume in millilitres,
- 9.3.5.3 Vapor temperature in °C to the nearest 0.5°C,
- 9.3.5.4 Temperature of the boiling liquid in °C to the nearest 1°C,
- 9.3.5.5 Atmospheric pressure in kPa (mm Hg), and
- 9.3.5.6 Pressure drop in the column in kPa (mm Hg).

9.3.6 If signs of flooding are observed, reduce the heating rate while continuing takeoff until steady conditions are restored. If a cut point is encountered during this period, stop the distillation, cool the charge, and recombine the off-condition cuts. Restart the distillation with a period at total reflux, not to exceed 15 min, to restore operating conditions before continuing takeoff. Do not make a cut within 5°C of startup.

9.3.7 Continue taking cuts until the desired maximum vapor temperature is reached or until the charge shows signs of cracking. Pronounced cracking is evidenced by a fog appearing in the flask and later at the reflux divider. Do not allow the vapor temperature to exceed 210°C nor the temperature of the boiling liquid to exceed 310°C.

9.3.8 Shut off the reflux valve and the heating system. Allow the contents to cool to such a temperature that the distillation can be commenced at 13.3 kPa (100 mm Hg) without flooding.

This temperature can be estimated by adding the ΔT between the liquid and vapor temperatures found for the column during atmospheric operation to the expected initial vapor temperature at the reduced pressure, or by subtracting the ΔT from the last recorded liquid temperature.

NOTE 3—Cooling of the liquid in the flask can be accelerated by blowing a gentle stream of compressed air onto the flask after its heating mantle has been removed. Avoid strong jets of cold air. Alternately, turn on coolant in the quench coil of the flask, if used.

9.3.9 Weigh all fractions and determine their densities.

9.3.10 Submit the first distillate fraction for analysis by gas chromatography.

9.4 Distillation at 13.3 kPa (100 mm Hg):

9.4.1 If further cuts at higher temperatures are required, distillation can be continued at reduced pressures, subject to the maximum temperature that the boiling liquid will stand without significant cracking. This is about 310°C in most cases. Notable exceptions are crude oils containing heat-sensitive sulfur compounds. In any case, do not make a cut within 5°C of the temperature at startup because the column will not be at equilibrium.

9.4.2 Connect a vacuum pumping and control system to the apparatus as shown in Fig. 1.

9.4.3 Start the vacuum pump and adjust the pressure downward gradually to the value of 13.3 kPa (100 mm Hg) or set the pressure regulator at this value. The temperature of the liquid in the flask must be below that at which it will boil at 13.3 kPa (100 mm Hg). If the liquid boils before this pressure is reached, increase the pressure and cool further until the desired pressure can be achieved without boiling.

9.4.4 Apply heat to the boiler and reestablish reflux at any moderate rate in the reflux divider for about 15 min to reheat the column to operating temperature. Momentarily stop heat input and raise the pressure with N₂ for 1 min to drop the holdup into the distillation flask.

9.4.5 Reapply heat to the distillation flask and adjust the rate of heating to maintain a constant pressure drop equivalent to the boilup rate of approximately 75 % of the maximum rate for this pressure and begin takeoff without delay. The approximate pressure drops required for this purpose are indicated in Fig. 3. Maintain a column insulation temperature 0 to 5°C below the vapor temperature throughout the operation.

9.4.6 Remove separately, cuts of suitable size as in 9.3.4.

9.4.7 At the end of each distillate fraction and at each cut point, record the following observations:

9.4.7.1 Time in hours and minutes,

9.4.7.2 Volume in millilitres observed at ambient temperature,

9.4.7.3 Vapor temperature in °C to the nearest 0.5°C with correction, if any,

9.4.7.4 Temperature of the boiling liquid in °C to the nearest 1°C,

9.4.7.5 Pressure drop in the column in kPa (mm Hg),

9.4.7.6 Operating pressure measured at the top of the column in kPa (mm Hg) absolute with correction, if any, and

9.4.7.7 AET using Table 3. If AET cannot be obtained from Table 3, it must be calculated from the equation in Annex A8. Fig. 5 is provided only as a guide in estimating the cut points during distillation.

9.4.8 Continue taking cuts until the desired maximum point is reached or until the charge shows signs of cracking. Pronounced cracking is evidenced by the evolution of gases as indicated by rising pressure as well as a fog appearing in the flask (see Note 3). Do not allow the temperature of the boiling liquid to exceed 310°C. (**Warning**—Automatic vacuum controllers could mask a slight rise in pressure due to cracking. Vigilance is required to avoid this.)

9.4.9 Shut off the reflux valve and the heating system. Allow

the contents to cool to such a temperature that the distillation can be commenced at a lower pressure without boiling. This temperature can be estimated by adding the ΔT between the liquid and vapor temperatures found for the column during operation to the expected initial vapor temperature at the lower pressure, or by subtracting the ΔT from the last recorded liquid temperature.

9.4.10 Weigh all fractions and determine their densities at 15°C.

9.5 Distillation at Lower Pressures:

9.5.1 If the final cut point has not been reached, distillation can be continued at a lower pressure subject to the same limitation as before (see 9.4.1). Only one pressure level between 13.3 kPa (100 mm Hg) and 0.266 kPa (2 mm Hg) is permitted. Where the maximum cut point is 400°C AET, the minimum pressure is recommended.

9.5.2 Adjust the pressure to the desired level. If the liquid boils before the pressure is reached, increase the pressure and cool further until the desired pressure can be achieved without boiling. Follow the procedure in 9.4.4.

9.5.3 Circulate cooling water in the condenser and liquid cooler either at ambient temperature or warmed to a temperature that will ensure that wax does not crystallize in the condenser or takeoff lines. Alternatively, leave the cooling coils full of water but vented and not circulating, or else circulate a stream of air instead of water as a coolant.

9.5.4 Continue vacuum operation as in 9.4.5 through 9.4.8. During this operation, a reflux ratio of 2:1 is allowed if mutually agreed upon in advance and noted in the report. Convert observed and corrected vapor temperatures to atmospheric equivalents using Table 4 or Table 5 or Annex A8. Fig. 5 is provided only as a guide in estimating the cut points during distillation.

9.5.5 Check periodically that the condensate drips normally in the condenser and that the distillate flows smoothly into the takeoff line. If crystallization is observed, allow the coolant in the condenser to warm as in 9.5.3.

9.5.6 When the final cut point has been reached, or when

TABLE 3 Conversion of Temperatures to Atmospheric Equivalent from Measurements at 13.3 kPa (100 mm Hg)

Temperature, °C	0	1	2	3	4	5	6	7	8	9
50	108.5	109.7	110.8	112.0	113.1	114.2	115.4	116.5	117.6	118.8
60	119.9	121.0	122.2	123.3	124.4	125.6	126.7	127.9	129.0	130.1
70	131.3	132.4	133.5	134.7	135.8	136.9	138.0	139.2	140.3	141.4
80	142.6	143.7	144.8	146.0	147.1	148.2	149.4	150.5	151.6	152.7
90	153.9	155.0	156.1	157.2	158.4	159.5	160.6	161.8	162.9	164.0
100	165.1	166.3	167.4	168.5	169.6	170.8	171.9	173.0	174.1	175.3
110	176.4	177.5	178.6	179.7	180.9	182.0	183.1	184.2	185.4	186.5
120	187.6	188.7	189.8	191.0	192.1	193.2	194.3	195.4	196.6	197.7
130	198.8	199.9	201.0	202.1	203.3	204.4	205.5	206.6	207.7	208.8
140	210.0	211.1	212.2	213.3	214.4	215.5	216.6	217.8	218.9	220.0
150	221.1	223.2	223.3	224.4	225.6	226.7	227.8	228.9	230.0	231.1
160	232.2	233.3	234.4	235.6	236.7	237.8	238.9	240.0	241.1	242.2
170	243.3	244.4	245.5	246.6	247.7	248.9	250.0	251.1	252.2	253.3
180	254.4	255.5	256.6	257.7	258.8	259.9	261.0	262.1	263.2	264.3
190	265.4	266.5	267.6	268.7	269.8	270.9	272.0	273.2	274.3	275.4
200	276.5	277.6	278.7	279.8	280.9	282.0	283.1	284.2	285.3	286.4
210	287.5	288.5	289.6	290.7	291.8	292.9	294.0	295.1	296.2	297.2
220	298.4	299.5	300.6	301.7	302.8	303.9	305.0	306.1	307.2	308.6
230	309.4	310.5	311.6	312.7	313.7	314.8	315.9	317.0	318.1	319.2
240	320.3	321.4	322.5	323.6	324.7	325.8	326.8	327.9	329.0	330.1
250	331.2	332.3	333.4	334.5	335.6	336.6	337.7	338.8	339.9	341.0

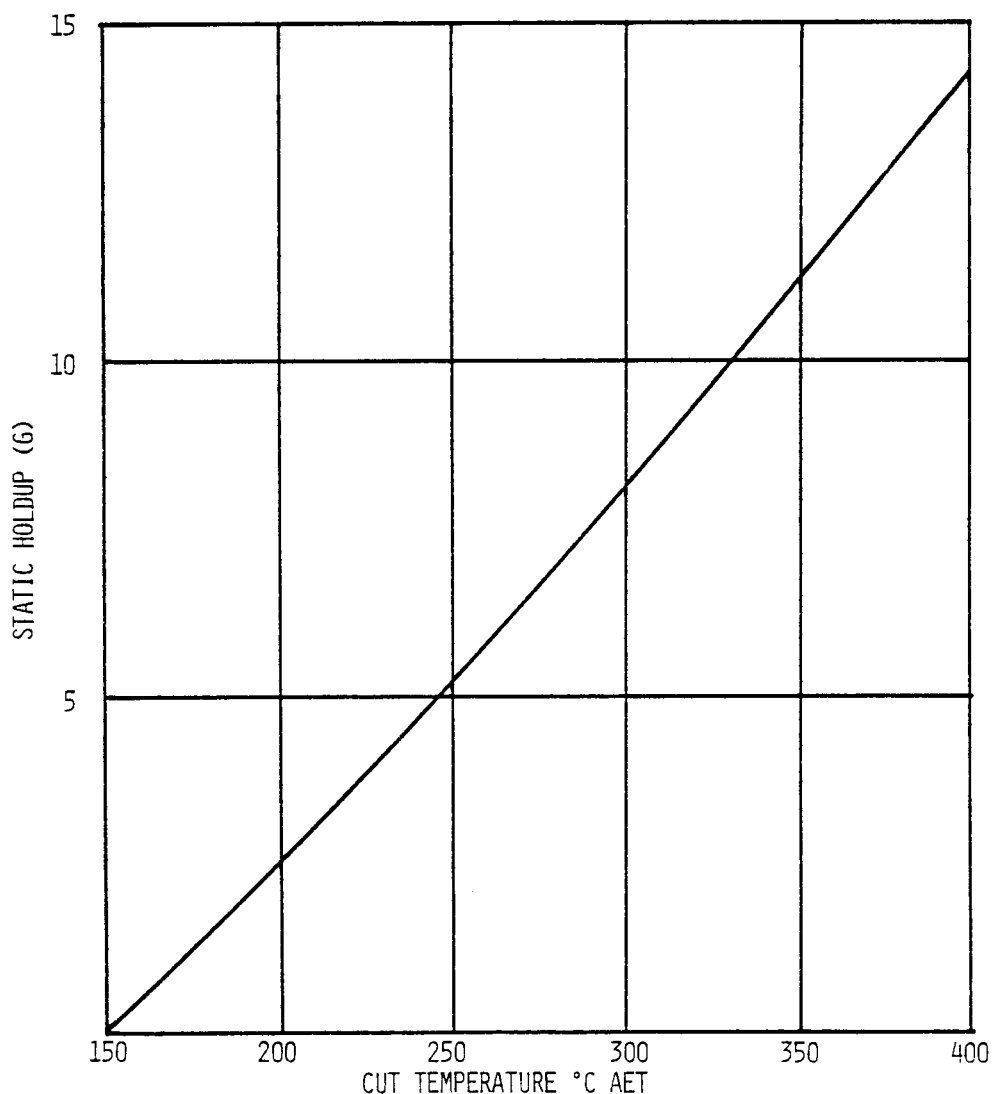

FIG. 5 Approximate Static Holdup for Average Crude Oil Using 4 mm Propak in a 25-mm ID × 570-mm Column

limits of boiling liquid temperature and column pressure prevent further distillation, turn off the reflux valve and heating system and allow to cool with the vacuum still applied.

9.5.7 When the temperature of the residue in the flask has fallen below 230°C, shut off the vacuum pump. Vent the fractionating unit with nitrogen or other inert gas. Do not use air. (**Warning**—Air is suspected of initiating explosions in fractionating units that are vented while too hot, such as at the end of a run.)

9.5.8 Stop circulation of coolant in the condenser and ancillary equipment. Disconnect the flask. Recover the static holdup of the column (wettage) by distilling a small quantity of solvent such as toluene in a separate flask to wash the column, condenser, and takeoff system. Evaporate the solvent from the collected residue at 10°C above the boiling point of the solvent, using a small purge of nitrogen. For distillations not involving disagreement, or by mutual consent, the holdup can be estimated using a graph similar to Fig. 5. The density of the holdup is estimated by extrapolation of the density line for the preceding cuts. The static holdup can be treated as a separate small cut or blended into the bottoms before inspections are

made. The latter must be done if other analyses besides density are to be performed on the residue.

9.5.9 Weigh all fractions and the residue in the flask and determine their densities at 15°C by Test Method D 4052 or by another suitable method. Convert the density to 15°C, if necessary.

NOTE 4—Heavier flasks, such as those for 50 and 70-mm diameter columns, are not normally removed for weighing. In these cases the residue can be discharged at a temperature not over 200°C into a tared container for weighing. Nitrogen pressure of approximately 6.7 kPa (50 mm Hg) will be sufficient for this. Wettage in these cases will include that of the column and the flask together.

10. Calculation

10.1 Calculate the mass % of each distillate fraction and the residue to the 0.1 mass %, using Eq 1.

$$\text{mass \%} = 100(m / M) \quad (1)$$

where:

m = mass of fraction or residue, g, and
 M = mass of dry crude oil charged, g.

TABLE 4 Conversion of Temperatures to Atmospheric Equivalent from Measurements at 1.33 kPa (10 mm Hg)

Temperature, °C	0	1	2	3	4	5	6	7	8	9
50	165.8	167.1	168.3	169.6	170.8	172.1	173.3	174.6	175.9	177.1
60	178.4	179.6	180.9	182.1	183.4	184.6	185.9	187.1	188.4	189.6
70	190.9	192.1	193.4	194.6	195.9	197.1	198.4	199.6	200.9	202.1
80	203.4	204.6	205.9	207.1	208.3	209.6	210.8	212.1	213.3	214.5
90	215.8	217.0	218.3	219.5	220.7	222.0	223.2	224.4	225.7	226.9
100	228.1	229.4	230.6	231.8	233.1	234.3	235.5	236.8	238.0	239.2
110	240.4	241.7	242.9	244.1	245.4	246.6	247.8	249.0	250.3	251.5
120	252.7	253.9	255.1	256.4	257.6	258.8	260.0	261.2	262.5	263.7
130	264.9	266.1	267.3	268.5	269.8	271.0	272.2	273.4	274.6	275.8
140	277.0	278.3	279.5	280.7	281.9	283.1	284.3	285.5	286.7	287.9
150	289.2	290.3	291.5	292.8	294.0	295.2	296.4	297.6	298.8	300.0
160	301.2	302.4	303.6	304.8	306.0	307.2	308.4	309.6	310.8	312.0
170	313.2	314.4	315.6	316.8	317.9	319.1	320.3	321.5	322.7	323.9
180	325.1	326.3	327.5	328.7	329.9	331.1	332.2	333.4	334.6	335.8
190	337.0	338.2	339.4	340.5	341.7	342.9	344.1	345.3	346.5	347.6
200	348.8	350.0	351.2	352.4	353.5	354.7	355.9	357.1	358.3	359.4
210	360.6	361.8	363.0	364.1	365.3	366.5	367.7	368.8	370.0	371.2
220	372.3	373.5	374.7	375.9	377.0	378.2	379.4	380.5	381.7	382.9
230	384.0	385.2	386.4	387.5	388.7	389.8	391.0	392.2	393.3	394.5
240	395.7	396.8	398.0	399.1	400.3	401.5	402.6	403.8	404.9	406.1
250	407.2	408.4	409.6	410.7	411.9	413.0	414.2	415.3	416.5	417.6

TABLE 5 Conversion of Temperatures to Atmospheric Equivalent from Measurements at 0.266 kPa (2 mm Hg)

Temperature, °C	0	1	2	3	4	5	6	7	8	9
50	201.1	202.4	203.8	205.1	206.4	207.7	209.1	210.4	211.7	213.0
60	214.4	215.7	217.0	218.3	219.6	221.0	222.3	223.6	224.9	226.2
70	227.6	228.9	230.2	231.5	232.8	234.1	235.4	236.7	238.0	239.4
80	240.7	242.0	243.3	244.6	245.9	247.2	248.5	249.8	251.1	252.4
90	253.7	255.0	256.3	257.6	258.9	260.2	261.5	262.8	264.1	265.4
100	266.7	268.0	269.2	270.5	271.8	273.1	274.4	275.7	277.0	278.3
110	279.5	280.8	282.1	283.4	284.7	286.0	287.2	288.5	289.8	291.1
120	292.4	293.6	294.9	296.2	297.5	298.7	300.0	301.3	302.6	303.8
130	305.1	306.4	307.6	308.9	310.2	311.5	312.7	314.0	315.2	316.5
140	317.8	319.0	320.3	321.6	322.8	324.1	325.3	326.6	327.9	329.1
150	330.4	331.6	332.9	334.1	335.4	336.6	337.9	339.2	340.4	341.7
160	342.9	344.2	345.4	346.6	347.9	349.1	350.4	351.6	352.9	354.1
170	355.4	356.6	357.8	359.1	360.3	361.6	362.8	364.0	365.3	366.5
180	367.8	369.0	370.2	371.5	372.7	373.9	375.2	376.4	377.6	378.8
190	380.1	381.3	382.5	383.8	385.0	386.2	387.4	388.7	389.9	391.1
200	392.3	393.5	394.8	396.0	397.2	398.4	399.6	400.9	402.1	403.3
210	404.5	405.7	406.9	408.1	409.4	410.6	411.8	413.0	414.2	415.4
220	416.6	417.8	419.0	420.2	421.4	422.7	423.9	425.1	426.3	427.5
230	428.7	429.9	431.1	432.3	433.5	434.7	435.9	437.1	438.3	439.5
240	440.7	441.8	443.0	444.2	445.4	446.6	447.8	449.0	450.2	451.4
250	452.6	453.8	454.9	456.1	457.3	458.5	459.7	460.9	462.1	463.2

10.1.1 The first fraction is the gas fraction collected in the balloon. If this fraction is less than 0.1 mass %, it can be ignored.

10.1.2 The second fraction (or first, if no gas is collected) is the condensate in the dry ice trap. With density at 15°C calculated from the gas chromatographic data on a fixed gas free basis, its volume can be computed.

10.1.3 The holdup is treated either as a separate cut or added to the residue fraction, in accordance with agreement. The amount of holdup is determined by actual recovery by solvent washing, as directed in 9.5.8, or estimated from Fig. 5.

10.2 Calculate the percent loss to the nearest 0.1 mass %, using Eq 2.

$$\text{Loss} = 100 - (\Sigma 100(m/M)) \quad (2)$$

The weight loss as calculated above must not be greater than 0.4 %, otherwise the distillation must be discarded. Losses less than this should be allocated two thirds to the trap cut and one

third to the first naphtha cut. Where there is no trap cut, the acceptable losses are to be normalized among all cuts.

10.3 Calculate the volume of the sample of crude oil in millilitres at 15°C, using Eq 3.

$$V = (M/D) \quad (3)$$

where:

D = density of charge at 15°C, g/mL,

M = mass of dry charge, g, and

V = volume of charge, mL.

10.4 Calculate the volume of each fraction and of the residue in millilitres at 15°C, using Eq 4.

$$v = m/d \quad (4)$$

where:

d = density of the fraction or residue at 15°C, g/mL,

m = mass of fraction or residue corrected for loss, g, and

v = volume of fraction, mL.

10.5 Calculate the volume % of each distillate fraction to the nearest 0.1 volume %, using Eq 5.

$$\text{vol \%} = 100(v/V) \quad (5)$$

10.6 Calculate the volume % gain or loss to the nearest 0.1 volume %, using Eq 6.

$$\text{Loss} = 100 - (\Sigma 100(v/V)) \quad (6)$$

Usually, the above expression is negative due to volume expansion. Normalize any apparent expansion or contraction among fractions boiling below 150°C in proportion to their yields.

NOTE 5—In view of the foregoing rules for establishing yields, the ratio of mass to volume is not precise enough to be used to calculate the density of any distillate fractions or residue.

11. Report

11.1 A summary sheet for the run must include:

11.1.1 The mass of the dry sample charged, g,

11.1.2 The density of the sample at 15°C, g/mL,

11.1.3 The volume of the sample at 15°C, mL,

11.1.4 The gain or loss in mass and volume to the nearest 0.1 %,

11.1.5 The volume and mass % of each fraction to the nearest 0.1 %,

11.1.6 The cumulative volume and mass percentages, and

11.1.7 The mass of water, if any.

11.2 The gas, debutanized naphtha, and succeeding fractions are listed in order of ascending boiling point with residue recorded last.

11.3 The observations made in 9.3.5, 9.4.7, and 9.5.4 are included as a second sheet, which is normally attached to the summary sheet.

11.4 Make plots of the temperature in °C AET as the

ordinate (y—axis) versus the percentage mass and volume distilled as the abscissa (x—axis). These are the final TBP distillation curves.

12. Precision and Bias

12.1 The precision of the method as determined by the statistical examination of interlaboratory test results is described below.

12.2 *Repeatability*—The difference between successive results obtained by the same operator with the same apparatus under constant operating conditions on identical test material would, in the long run, in the normal and correct operation of this test method, exceed the values indicated below in one case in twenty. (Repeatability is under statistical review.)

12.3 *Reproducibility*—The difference between two single and independent results obtained by different operators working in different laboratories on identical test material would, in the normal and correct operation of this test method, exceed the values indicated below in one case in twenty.

	mass %	vol %
Atmospheric pressure	1.2	1.2
Vacuum pressure	1.4	1.5

12.4 Bias:

12.4.1 *Absolute Bias*—Since there is no accepted reference material suitable for determining the bias for the procedure in Test Method D 2892 in determining distillation properties of crude petroleum, bias cannot be determined.

12.4.2 *Relative Bias*—TBP is defined under the conditions of this Test Method (see 1.2).

NOTE 6—The crude oil used for this precision statement had a density at 15°C equal to 0.859 and an average slope equal to 6°C per percent distilled.

13. Keywords

13.1 boiling point distillation; crude oil distillation; distillation; fractional distillation; TBP curves

ANNEXES

(Mandatory Information)

A1. TEST METHOD FOR THE DETERMINATION OF THE EFFICIENCY OF A DISTILLATION COLUMN

A1.1 Scope

A1.1.1 This test method is for determining the efficiency of a distillation column, under total reflux conditions using the test mixture *n*-heptane/methylcyclohexane at atmospheric pressure.

A1.1.2 The efficiency is not measured under vacuum conditions because there is no satisfactory test mixture that has a constant relative volatility with pressure.

A1.2 Significance and Use

A1.2.1 The efficiency of the distillation column must be between 14 and 18 theoretical plates to be used in Test Method D 2892 (see 6.1.3.2).

A1.2.2 The performance of particulate packings is well established in the literature. The data shown in Table 1 can be

used in place of this test method.

A1.3 Apparatus

A1.3.1 An example of a suitable apparatus is shown in Fig. A1.1. It consists of the following:

A1.3.1.1 *Calibration Flask*, of suitable size with a device for heating. An example of a suitable calibration flask is shown in Fig. A1.2.

A1.3.1.2 *Distillation Column and Condenser*.

A1.3.1.3 *Manometer*, or equivalent to measure the pressure drop in the column.

A1.4 Reagents and Materials

A1.4.1 The test mixture is a 50/50 mixture by volume of *n*-heptane and methylcyclohexane with refractive indexes of:

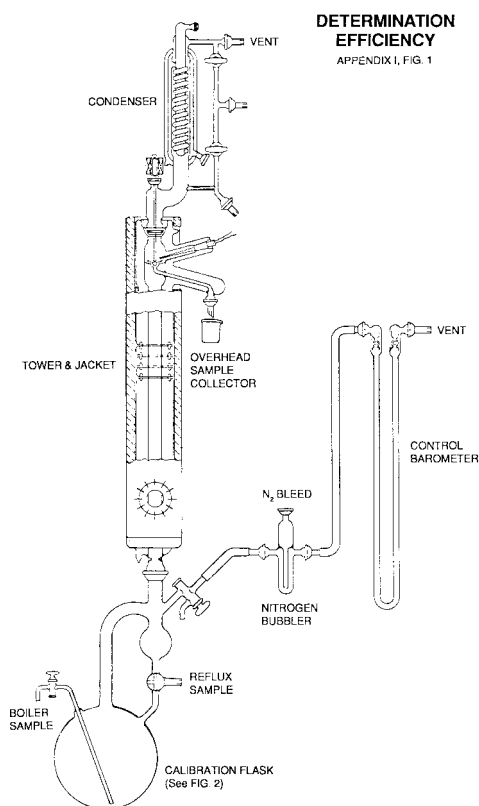

FIG. A1.1 Determination of Efficiency

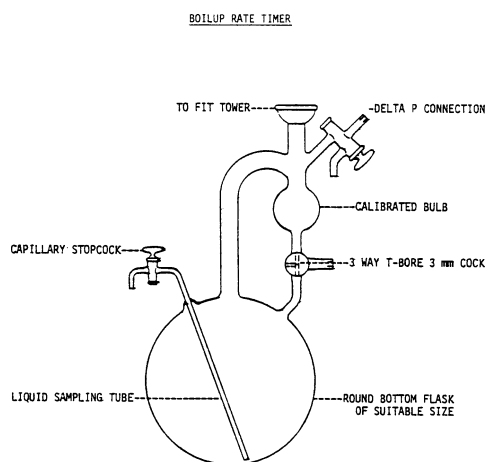

FIG. A1.2 Boiling Rate Timer

<i>n</i> -heptane	$n_D^{20} = 1.38764$
methylcyclohexane	$n_D^{20} = 1.42312$

A1.4.2 Chromatographic analysis of the components of the test mixture must show less than 0.01 % contamination with lighter compounds and greater than 99.75 % purity. They must be transparent to ultraviolet light at 260 to 270 nm to ensure freedom from aromatics.

A1.4.3 If the components do not meet the above specification, they can be purified either by redistillation in a 30 to 50 plate column, or by percolation through 200-mesh silica gel, discarding the first 10 % of the eluted liquid. Exercise care that the gel does not become overloaded.

A1.5 Preparation of Apparatus

A1.5.1 The distillation column and all the glassware must be clean and dry before proceeding with the test method described. Cleaning can be accomplished by washing with a strong industrial detergent. Rinse thoroughly, dry, and reassemble.

A1.5.2 Distill a small quantity of pure *n*-heptane at a high boilup rate for at least 5 min. Take off several small quantities through the overhead sampling system at intervals. Turn off the heat, remove the flask, and dry the column with air while still hot. To keep the apparatus completely dry, connect a moisture trap at the vent of the overhead condenser.

A1.6 Procedure

A1.6.1 Introduce into the distillation flask a quantity of test mixture equal to the minimum volume permitted for the column (see Table 1) but not more than two thirds of the capacity of the flask. Add some pieces of glass or porcelain to promote even boiling.

A1.6.2 Connect the flask to the pressure drop manometer as shown in Fig. A1.1.

A1.6.3 Circulate water at ambient temperature in the condenser.

A1.6.4 Apply heat to the flask until the test mixture boils, then increase the heat progressively up to the flood point. This will be noted by visible slugs of liquid in the packing or on the plates or by liquid filling the neck of the condenser and a sudden increase in pressure drop. Reduce heat to allow the flooding to subside. Increase the heat gradually to just below the flood point. Record boilup and ΔP measurements just below the flood point. This is considered the maximum rate.

A1.6.5 Adjust the heat input until the column is refluxing at a steady rate corresponding to about 200 mL/h times the cross-sectional area of the column in cm^2 .

A1.6.6 Maintain the column under total reflux for 1 h. Record the pressure drop and determine the boilup rate by timing the filling of the calibrated bulb.

A1.6.7 Take rapidly, and almost simultaneously, a sample of the flask liquid and reflux in sufficient quantity for the determination of the refractive indexes at 20°C but not more than 0.5 mL each. The duration of withdrawal of the reflux sample must not exceed 2 s.

A1.6.8 Measure refractive indexes of reflux and flask samples.

A1.6.9 Repeat A1.6.7 and A1.6.8 at intervals from 12 to 30 min until refractive index measurements indicate that steady conditions of maximum efficiency have been attained.

A1.6.10 Check the ultraviolet absorption of the flask sample at 260 and 270 nm. If an absorption is detected, aromatics contamination is present and the efficiency determination will be in error. The apparatus must be cleaned and the test mixture repercolated through fresh silica gel before starting over.

A1.6.11 Repeat successively the series of operations A1.6.5 to A1.6.10, without preflooding, at four or more other boilup rates approximately equally spaced between $(200 \text{ mL/h}) \times \text{cm}^2$ and the maximum rate. One of these should be at a rate that is above 90 % of maximum.

A1.7 Calculation

A1.7.1 For each pair of samples taken, determine the molar composition of each sample by comparison of its refractive index with a curve of refractive index versus molar composition of *n*-heptane drawn from the following data:

Molar fraction of <i>n</i> -heptane	Refractive Index
0.00	1.4231
0.10	1.4191
0.20	1.4151
0.30	1.4113
0.40	1.4076
0.50	1.4040
0.60	1.4005
0.70	1.3971
0.80	1.3939
0.90	1.3907
1.00	1.3876

A1.7.2 Calculate the number of theoretical plates in the column by means of the Fenske equation⁶ [Eq A1.1]:

$$N = \frac{\log \frac{X_D}{1-X_D} - \log \frac{X_O}{1-X_O}}{\log \alpha} - 1 \tag{A1.1}$$

where:

- N* = number of theoretical plates in the column,
- α = relative volatility of *n*-heptane to methylcyclohexane,
- X_D* = molar fraction of *n*-heptane in the reflux liquid, and
- X_O* = molar fraction of *n*-heptane in the flask liquid.

A1.7.3 Fig. A1.3 is a graphical solution to the equation for the *n*-heptane-methylcyclohexane binary. Vapor-liquid equilibria have been determined by Adler et al.⁷ and relative volatility

is taken as 1.075 as recommended by IUPAC.⁸

A1.7.4 The efficiency of the column is numerically equal to the difference between the plate numbers indicated on the curve for top and bottom samples. Note that one plate is subtracted for the contribution of the flask, or alternatively a sample of liquid from the bottom of the column rather than the flask can be taken to obtain the efficiency of the column alone.

A1.7.5 For packed columns, draw curves of HETP in millimetres, ΔP in kPa and kPa/m, and number of theoretical plates as a function of boilup rate expressed in mL/h and absolute rate in (mL/h) \times cm². For real plate columns, the efficiency should be plotted as percent of a theoretical plate per real plate and ΔP should be plotted both in kPa/real plate and in absolute units of kPa/theoretical plate using the same units for boilup rate as above for packed columns. The efficiency of the column corresponds to the value of *N* determined from the curve at 75 % of its maximum boilup rate.

A1.7.6 Typical curves for the popular packings and plate columns are shown in Figs. A1.4-A1.7. These columns are to be used in the unreflooded condition. Data on other packings are inconclusive or incomplete in the literature and are not included.

A1.7.7 Draw a vertical line on the graph at 75 % of maximum boilup and read the HETP or the plate efficiency corresponding to this rate.

A1.7.8 Multiply the HETP in millimetres by 14 and by 18 for packed columns to obtain the range of permissible heights of packing for use in this test method. If the efficiency of a packed column is greater than 18 plates, as measured above, the efficiency can be reduced by removing a suitable amount of packing without detriment to performance.

A1.7.9 For real plate columns, divide 14 and 18 by plate efficiency to obtain the number of actual plates (rounded to the

⁶ A more convenient form of the equation from Fenske, M. R., *Industrial and Engineering Chemistry*, Vol 24, 1932, p. 482.

⁷ Adler et al., *American Institute of Chemical Engineers*, Vol 12, 1966, p. 629.

⁸ Seig, *Chemie-Ingenieur-Technik*, Vol 22, 1950, p. 322.

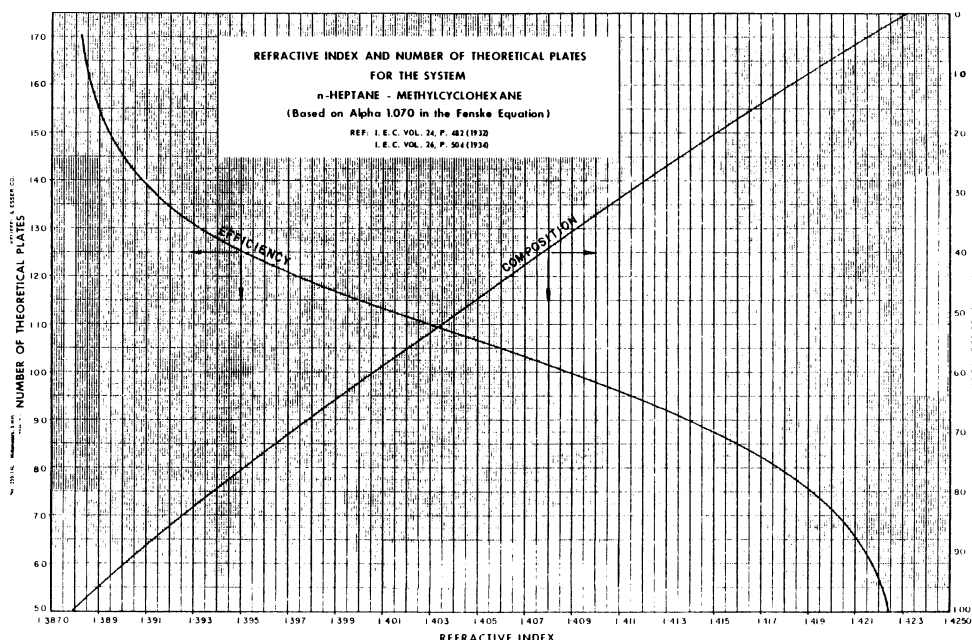

FIG. A1.3 Refractive Index

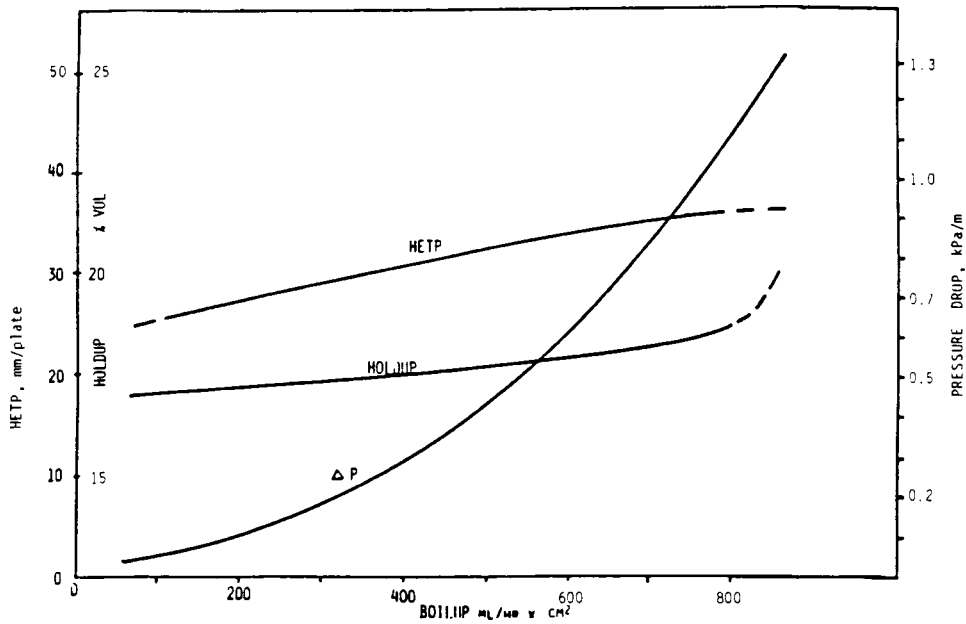

FIG. A1.4 4-mm Propak in 25-mm Inside Diameter Towers

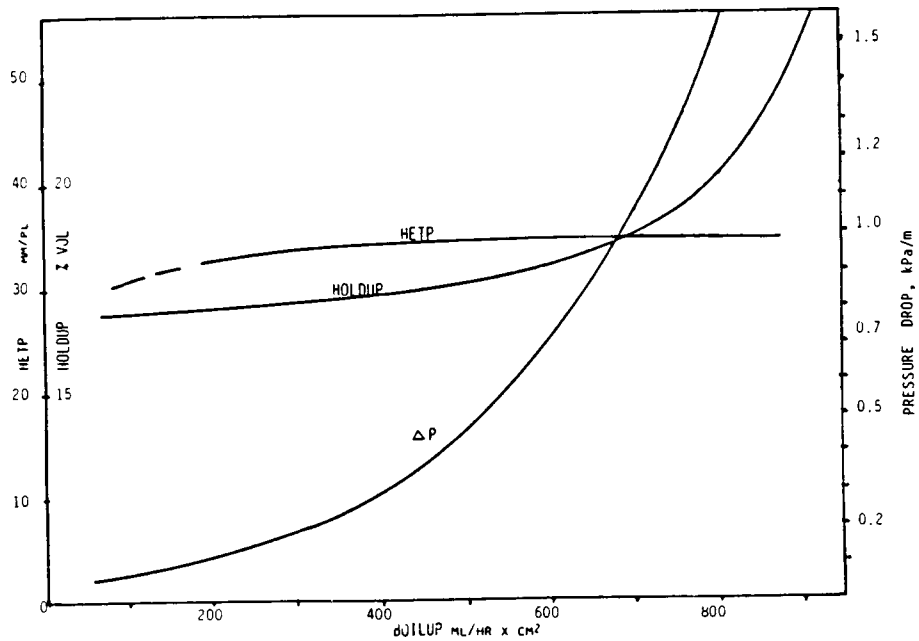

FIG. A1.5 4-mm Propak in 50-mm Inside Diameter Towers

nearest integer) for an acceptable column.

A1.8 Precision and Bias

A1.8.1 No statement is made concerning either the precision or bias of Annex A1 for measuring the efficiency of a

distillation column because the result is used to determine whether there is conformance to the criteria stated in Test Method D 2892.

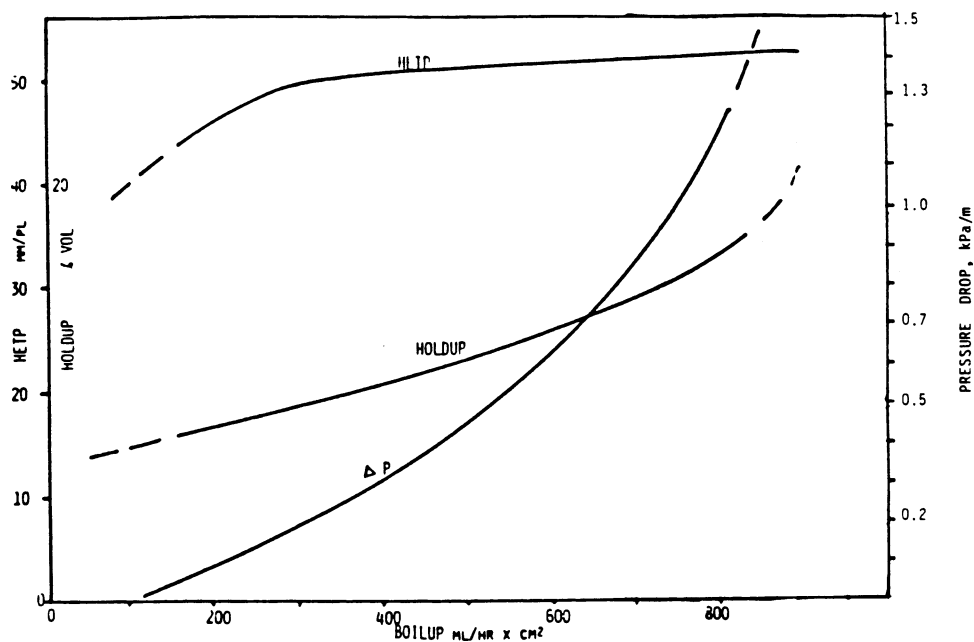
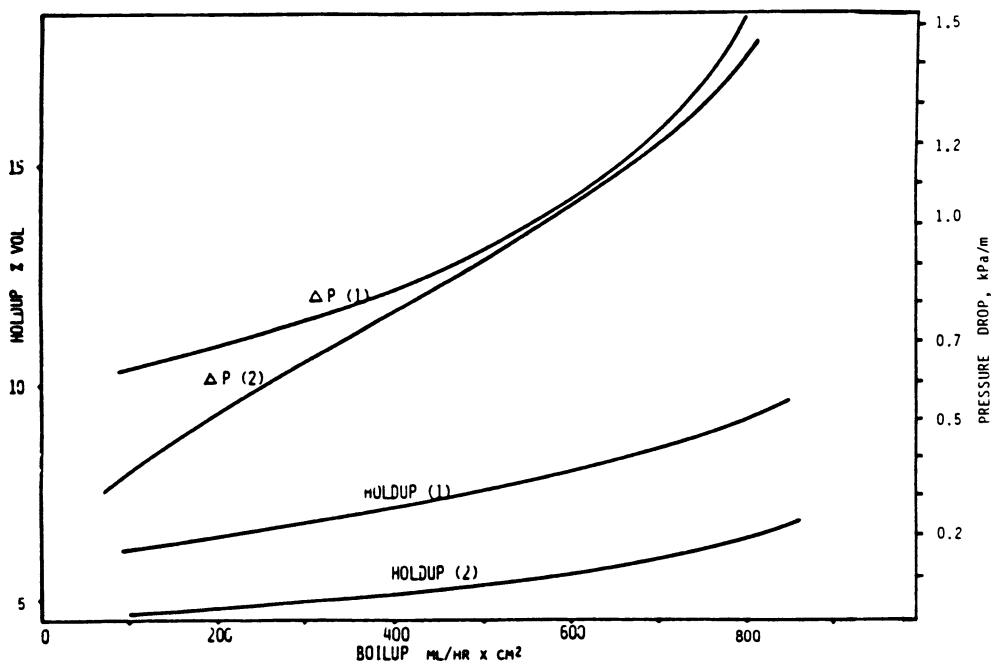

FIG. A1.6 6-mm Propak in 50-mm Towers



NOTE 1—(1) Analytical Chemistry, ANCHA, Vol 39, 1967, p. 286. (2) Exxon unpublished data.

FIG. A1.7 Perforated Plates 50-mm Inside Diameter

A2. TEST METHOD FOR THE DETERMINATION OF THE DYNAMIC HOLDUP OF A DISTILLATION COLUMN

A2.1 Scope

A2.1.1 This test method is for determining the dynamic holdup of a distillation column using a test mixture of stearic acid in *n*-heptane.

A2.2 Summary of Test Method

A2.2.1 A test mixture, composed of stearic acid in

n-heptane, is distilled under total reflux conditions. From the difference in concentration of stearic acid in the initial mixture and in the mixture during refluxing, the dynamic holdup of the column is calculated.

A2.3 Significance and Use

A2.3.1 The amount of sample charged to a particular

distillation column must be of such a size that the dynamic holdup of that column is between 2 and 4 % of that charge size at 75 % boilup rate (see 9.1.1).

A2.3.2 The performance of the particle packings is well enough defined in the literature that the data in Table 1 can be used instead of this test method.

A2.4 Apparatus

A2.4.1 The apparatus is identical to that described in A1.3, Fig. A1.1.

A2.5 Reagents and Materials

A2.5.1 The test mixture consists of 20 mass % stearic acid in *n*-heptane. The *n*-heptane shall have a refractive index at 20°C of 1.3878 ± 0.0002 . The stearic acid shall be greater than 95 % pure and have a melting point of 68 to 70°C.

A2.6 Preparation of Apparatus

A2.6.1 See A1.5.

A2.7 Procedure

A2.7.1 Measure the concentration of stearic acid in the test mixture by a convenient means. For example, titrate with 0.1 *N* NaOH solution to a pH of 9.0 potentiometrically. Record the results as mass % stearic acid (P_O).

A2.7.2 Introduce pieces of glass or porcelain into the flask or use a good stirrer to promote even boiling.

A2.7.3 Add 1 L of the test mixture for a 25-mm inside diameter column or 4 L for a 50-mm column to the flask. Weigh the flask to the nearest 1 g.

A2.7.4 Attach the flask to the distillation column and to the ΔP measuring system.

A2.7.5 Circulate water at ambient temperature through the condenser.

A2.7.6 Apply heat to the flask and bring the test mixture to a boil. Adjust the boilup rate to approximately 200 mL/h times the cross-sectional area of the column in centimetres squared measured by timing the filling of the calibrated bulb. When the desired rate has been established, hold for 30 min noting the pressure drop.

A2.7.7 Sample the reflux and the flask liquids, taking samples of not more than the amount necessary for a determination, and immediately observe and record the boilup rate and ΔP .

A2.7.8 Analyze the reflux and flask samples to determine the concentration of stearic acid in mass % (P).

A2.7.9 Repeat A2.7.7 and A2.7.8 at 15 min intervals until the concentration of stearic acid in the flask sample is steady.

A2.7.10 Raise the boilup rate by an additional 200 (mL/h) \times cm² and repeat A2.7.7-A2.7.9.

A2.7.11 Continue making measurements as above at increments of about 200 (mL/h) \times cm² until near the flood point. At least four sets of measurements should be obtained including one near the maximum operable rate.

A2.8 Calculation

A2.8.1 Calculate the dynamic holdup of the column for each observation, using Eq A2.1:

$$H = \frac{P - P_O}{P} \times \frac{M}{d} \quad (\text{A2.1})$$

where:

H = dynamic holdup in column, mLs at 15°C,

M = mass of test mixture in the flask, g,

P_O = stearic acid in the test mixture initially, mass %, and

P = stearic acid in the test mixture after distillation, mass %, and

d = density of *n*-heptane, 0.688 g/mL at 15°C.

A2.8.2 Calculate the dynamic holdup per theoretical plate at each rate of boilup at which the determination was made, using Eq A2.2:

$$h = \frac{H}{N} \quad (\text{A2.2})$$

where:

N = efficiency in theoretical plates of the column under total reflux at this boilup rate (see Annex A1).

A2.8.3 Convert the boilup measurement in litres per hour to rates per hour in (mL/h) \times cm². Convert also the ΔP measurements to kPa/m (mm Hg/m) and the holdup measurement to millilitres per theoretical plate.

A2.8.4 Plot all data as ordinates versus boilup rate in litres per hour and (mL/h) \times cm² as abscissa. Draw smooth curves through the points for holdup in millilitres and in millilitres per theoretical plate. The boilup versus ΔP measurements should be compared with those made in the efficiency measurements if available, to ensure that they are in reasonable agreement.

A2.8.5 Draw a vertical line at 75 % of maximum boilup rate. The dynamic holdup for the column will be that read from the intersection of the holdup curve and the line for 75 % of maximum boilup rate. The charge size, ranging from a holdup ratio from 2 to 4 % will thus be from 50 to 25 times the above figure.

A2.9 Precision and Bias

A2.9.1 No statement is made concerning either the precision or bias of Annex A2 for measuring dynamic holdup because the result is used to determine whether there is conformance to the criteria stated in Test Method D 2892.

A3. TEST METHOD FOR THE DETERMINATION OF THE HEAT LOSS IN A DISTILLATION COLUMN (STATIC CONDITIONS)

A3.1 Scope

A3.1.1 This test method is for determining the heat loss of a distillation column under static conditions when a temperature differential exists between the inner and outer walls of a distillation column.

A3.2 Summary of Test Method

A3.2.1 The outer wall of the column vacuum jacket is maintained at an elevated constant temperature. The temperature increase inside the column, as recorded by the sensor in the reflux divider, is a measure of the heat gained and thus heat lost by the column.

A3.3 Significance and Use

A3.3.1 It is important to have an effective silvered glass vacuum jacket surrounding the column and reflux divider. This reduces the effects of ambient air temperature near the distillation apparatus and promotes easier control at the maximum distillation temperatures. The use of a heat compensating mantle further reduces losses by reducing the temperature gradient between inside of the column and the ambient air.

A3.3.2 The test should be performed on all new glass vacuum jackets before use, and checked at least once per year thereafter.

A3.3.3 The heat loss as determined by this test method must be less than 30 % for the column to be acceptable for use in Test Method D 2892.

A3.4 Apparatus

A3.4.1 The column is enclosed in its heat compensating mantle with the thermocouple in place on the column wall.

A3.4.2 A twin pen chart recorder to monitor the column outer wall and heat sensor temperatures and an automatic proportioning controller for the heat input are recommended.

A3.5 Preparation of Apparatus

A3.5.1 The heat sensor location, response time, and calibration must be checked as specified in Annex A4 to Annex A6.

A3.5.2 To reduce chimney effects inside the column during the test, the top of the condenser must be closed.

A3.6 Procedure

A3.6.1 Record the time and ambient temperature.

A3.6.2 Apply heat to the outer wall of the column vacuum jacket. Adjust the heat progressively until the temperature sensor located on the column wall records a temperature 100°C above ambient. This condition provides a suitable temperature difference to measure without placing unnecessary thermal strain on the glassware. Attain the 100°C differential temperature within 30 min and maintain the column at this temperature for 1 h.

A3.6.3 Record the time, the temperature of column outer wall, and the temperature inside the column.

A3.7 Calculation

A3.7.1 Calculate the heat gained and thus lost by the column using Eq A3.1:

$$Q = \frac{B - A}{C - A} \times 100 \quad (\text{A3.1})$$

where:

A = ambient temperature, °C,

B = temperature inside column, °C, and

C = temperature of outer wall, °C.

or, when the differential temperature is 100°C, use Eq A3.2:

$$Q = B - A \quad (\text{A3.2})$$

A3.8 Precision and Bias

A3.8.1 No statement is made concerning either the precision or bias of Annex A3 for measuring heat loss because the result is used to determine whether there is conformance to the stated criteria (see A3.3.3).

A4. TEST METHOD FOR THE VERIFICATION OF TEMPERATURE SENSOR LOCATION

A4.1 Scope

A4.1.1 This test method is for determining whether the temperature sensor is in the proper position for optimum performance.

A4.2 Summary of Test Method

A4.2.1 The vapor temperature of a pure compound measured by the sensor and its recording instrument is compared to the accepted boiling point for the compound. The test is conducted both at atmospheric pressure and under vacuum of 0.133 kPa (1 mm Hg).

A4.3 Significance and Use

A4.3.1 A poorly positioned sensor can give temperatures that are in error due to inadequate heat supply from the vapors. It is especially important under vacuum when heat content of the vapor is at a minimum.

A4.3.2 The procedure is normally performed once only for the approval of a design and need not be repeated thereafter.

A4.4 Procedure

A4.4.1 *Atmospheric Distillation:*

A4.4.1.1 Assemble the apparatus for atmospheric distillation. Use cooling water at ambient temperature. Charge 0.5 to

1 L of pure, dry *n*-tetradecane containing less than 0.1 % light contaminants as determined by gas chromatography. Calibrate the temperature sensor as prescribed in Annex A6.

A4.4.1.2 Apply heat and establish equilibrium at a boilup rate of about $400 \text{ (mL/h)} \times \text{cm}^2$. This corresponds to a ΔP of about 0.4 kPa/m (3 mm Hg/m) for particle packing or 0.09 kPa/plate (0.07 mm Hg/plate) for real plate columns. Hold at these conditions for 15 min. If the vapor temperature drops more than 0.2°C, remove 2 % overhead at 5:1 reflux ratio and then again hold at total reflux for 15 min. Continue taking 2 % cuts as above until the vapor temperature remains steady within 0.2°C for 15 min at total reflux.

A4.4.1.3 Record the boiling point to the nearest 0.5°C and the atmospheric pressure to the nearest 0.1 kPa (1 mm Hg), using instruments calibrated in accordance with Annex A6.

A4.4.1.4 If the observed boiling point is not $253.5 \pm 0.5^\circ\text{C}$, the location of the sensor is suspect and must be corrected before use in this test method.

A4.4.2 *Vacuum Distillation:*

A4.4.2.1 Assemble the apparatus for vacuum distillation. Charge 0.5 to 1 L of pure, dry *n*-hexadecane containing less than 0.1 % light contaminants as determined by gas chromatography. Calibrate the temperature and vacuum instruments as prescribed in Annex A6.

A4.4.2.2 Reduce the pressure in the system to 0.133 kPa (1 mm Hg). Circulate air in the condenser to avoid crystallization.

A4.4.2.3 Apply heat and establish equilibrium at a boilup rate between 25 and 50 $(\text{mL/h}) \times \text{cm}^2$. This corresponds to a ΔP of about 0.133 kPa/m (1 mm Hg/m) or less for particle packing or 0.08 kPa/plate (0.06 mm Hg/plate) for real plate columns to 50-mm diameter. Hold at these conditions for 15 min.

A4.4.2.4 Remove 2 % overhead at 20:1 reflux ratio and then again hold at total reflux for 5 min. Record the boiling point to the nearest 0.5°C and the operating pressure to the nearest 0.05 kPa (0.3 mm Hg), using instruments calibrated as described in Annex A6.

A4.4.2.5 If the observed boiling point is not steady with 0.2°C at 0.133 kPa (1 mm Hg), remove 2 % cuts at 5:1 reflux ratio and then hold at total reflux for 15 min, repeating the above until total reflux conditions produce a steady temperature. Not more than three trials should be needed.

A4.4.2.6 If the observed boiling point is not $105.2 \pm 0.5^\circ\text{C}$ at 0.133 kPa (1 mm Hg), the location of the sensor is suspect and must be corrected before use in this test method.

A4.5 Precision and Bias

A4.5.1 No statement is made concerning either the precision or bias of Annex A4 for checking the location of the temperature sensor because the result is used to determine whether there is conformance to the criteria stated in A4.4.2.6.

A5. TEST METHOD FOR DETERMINATION OF TEMPERATURE RESPONSE TIME

A5.1 Scope

A5.1.1 This test method is for the determination of temperature response time based upon the rate of cooling of the sensor under prescribed conditions.

A5.2 Significance and Use

A5.2.1 This test method is performed to ensure that the sensor is able to respond to changes in temperature fast enough that no error due to lag is introduced in a rapidly rising temperature curve.

A5.2.2 The importance of this test method is greatest under vacuum conditions when the heat content of the vapors is minimal.

A5.3 Procedure

A5.3.1 Arrange a 1-L beaker of water on a hot plate with a glass thermowell supported vertically in the water. Maintain the temperature of the water at $90 \pm 5^\circ\text{C}$.

A5.3.2 Correct the sensor to an instrument, preferably with a digital readout, with readability to 0.1°C. Alternatively, connect the sensor to a strip chart recorder of suitable range

allowing interpolation to 0.1°C. Set the chart speed at 30 cm/h for readability.

A5.3.3 Insert the sensor into a hole in the center of one side of a closed cardboard box about 30 cm on a side. Hold the sensor in place by a friction fit on the joint. Allow the sensor to reach equilibrium temperature. Record the temperature when it becomes stable.

A5.3.4 Remove the sensor and insert it into the heated thermowell in the beaker of water. After the sensor has reached a temperature of 80°C, remove it and immediately insert it into the hole in the box. Note with a stopwatch, or record on the strip chart, the time interval while the sensor cools from 30°C above to 5°C above the temperature recorded in A5.3.3.

A5.3.5 A time interval in excess of 175 s is unacceptable.

A5.4 Precision and Bias

A5.4.1 No statement is made concerning either the precision or bias of Annex A5 for measuring temperature response because the result is used to determine whether there is conformance to the criteria stated in A5.3.5.

A6. PRACTICE FOR CALIBRATION OF SENSORS

A6.1 Principle

A6.1.1 This practice deals with the basic calibration of temperature sensors and vacuum sensors and their associated recording instruments.

A6.1.2 The temperature sensor and its associated instrument are calibrated by observing and recording the temperatures of the melting point and boiling point of pure compounds or eutectic mixtures.

A6.1.3 The vacuum sensor and its associated instrument are calibrated against a McLeod gage.

A6.2 Temperature Sensors

A6.2.1 *Apparatus*—A suitable apparatus is shown in Fig. A6.1. For the freezing point of water, a Dewar flask filled with crushed ice and water can be substituted. For the boiling point of water, use an equilibrium still or ebullimeter, a tensimeter, or other apparatus for measuring vapor-liquid equilibrium.

A6.2.2 *Procedure:*

A6.2.2.1 Ensure that approximately 0.5 mL of silicone oil or other inert liquid is in the bottom of the thermowell and insert one or more thermocouples or other sensors connected to their respective measuring instruments.

A6.2.2.2 Heat the melting point bath to a temperature 10°C above the melting point of the metal inside and hold this temperature at least 5 min to ensure that all of the metal is melted.

A6.2.2.3 Discontinue heat input to the melting point bath and observe and record the cooling curve. When the curve exhibits a plateau of constant temperature for longer than 1 min, the temperature of the recorded plateau is accepted as the calibration temperature. If the freezing plateau is too short, it can be prolonged by employing some heat during the cooling cycle. Alternatively, the melt bath may have become contaminated or excessively oxidized. In this case, replace the metal.

A6.2.2.4 Record the calibration temperature at each of the following points to the nearest 0.1°C:

Material	Temperature, °C
Ice	melting point
Water	boiling point
Tin: Lead: Cadmium (50:32:18)	melting point
Sn	melting point
Pb	melting point

A6.2.2.5 Set up a correction table by listing the correction to be added algebraically to the observed temperature to give the true temperature at each calibration point. A graphical plot of the above corrections connected by a smooth curve may be helpful in routine use.

A6.3 Vacuum Sensors

A6.3.1 *Apparatus:*

A6.3.1.1 Assemble a vacuum manifold such as that shown in Fig. A6.2. It shall be capable of maintaining steady pressures within 1% at all desired levels.

A6.3.1.2 For pressures between atmospheric down to 13.3 kPa (100 mm Hg), an evacuated mercury barometer or manometer is the primary reference standard. Fig. A6.3 shows a convenient design in which any internal air above the mercury is trapped in the fine tip at the top where it can be seen at a glance. For a suitably evacuated gage, there is no air in the tip visible to the unaided eye when vented. The glass shall be chemically clean inside.

A6.3.1.3 If air can be seen in the tip, clamp the gage in a horizontal position with the vacuum connection facing upward and the top of the gage lower than the bottom so as to expose the hole in the bottom of the central tube. Apply a vacuum of less than 0.0133 kPa (0.1 mm Hg) and heat the end of the gage containing the mercury with an infrared heat lamp or a hot air gun until the mercury comes to its boiling point. Continue heating slowly until the mercury in the central tube has partly distilled out into the outer tube. Condensed mercury on the wall will be evidence of this. Return the manometer to the vertical position and slowly release the vacuum. Verify that there is no air visible at the tip of the central tube when fully vented. (**Warning**—Mercury vapor is poisonous. Harmful or fatal if inhaled or ingested.)

A6.3.1.4 For pressures below 13.3 kPa, the nontilting McLeod gage is the primary standard and shall be carefully maintained.

A6.3.1.5 Choose a McLeod gage with a range such that the desired calibration pressure falls between 10 and 90 % of the scale. Before refilling with clean mercury, heat the empty reference McLeod gage at 250°C for at least 30 min at a

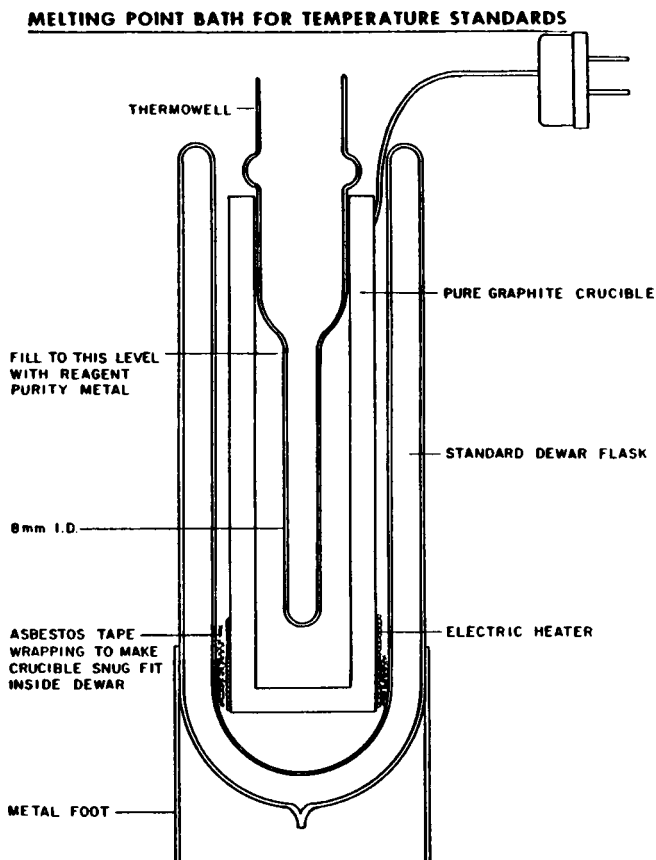

FIG. A6.1 Melting Point Bath for Temperature Standards

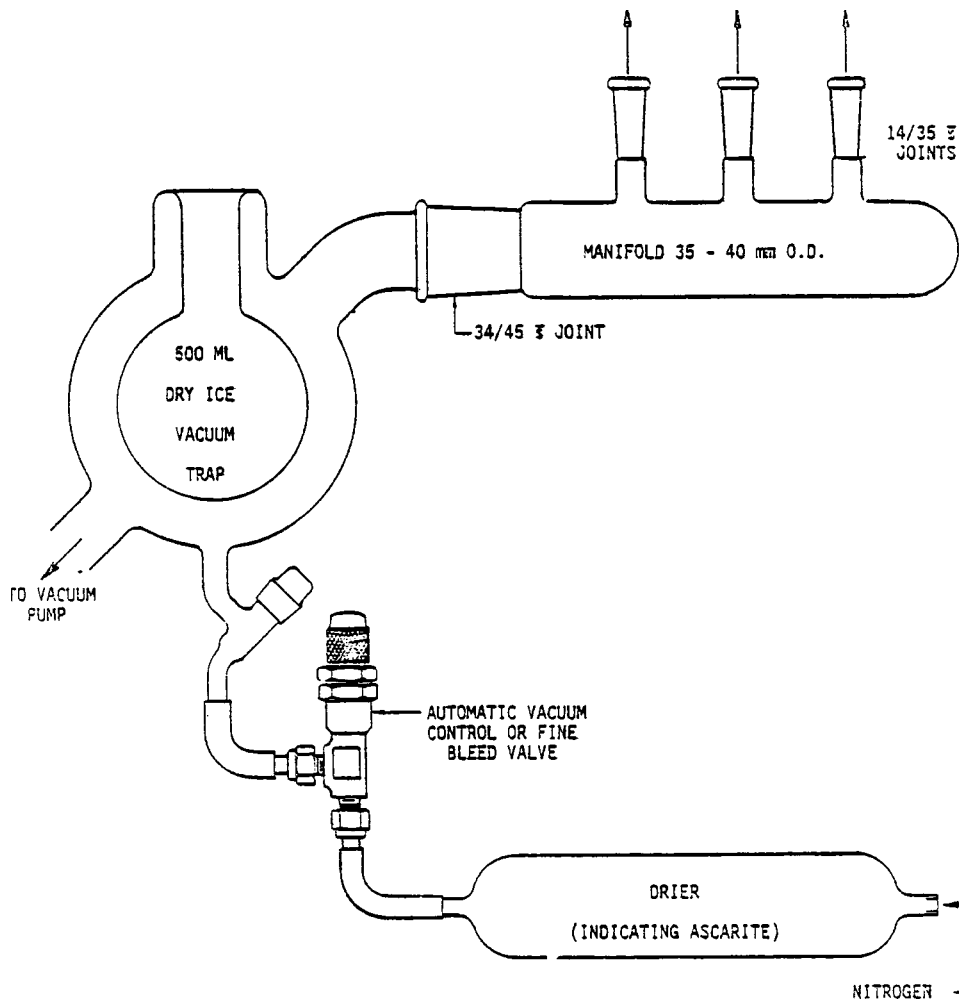

FIG. A6.2 Calibration of Vacuum Gages

pressure below 10 Pa (0.075 mm Hg). Thereafter, carefully protect the reference gage from exposure to moisture such as that from atmospheric air. The use of two reference McLeod gages of different pressure ranges is recommended as a precaution. If they agree at the test pressure, it is an indication that the system is free of moisture and other condensibles.

NOTE A6.1—The general principles of construction of McLeod gages are well-established. The dimensions and tolerances of such a gage are beyond the scope of this test method.

A6.3.1.6 Alternatively, certified secondary gages, electronic or otherwise, can be used, provided the output can be traced back to a primary standard. Secondary gages shall be re-certified at a regular basis, but at least once a year.

A6.3.2 Procedure:

A6.3.2.1 Set up the test manifold such as that shown in Fig. A6.2. Ensure that the test manifold is leak-free and can be maintained at a steady pressure at the required level. A suitable leak test is to pump down to a pressure below 0.1 kPa and

isolate the pump. Observe the pressure inside the unit for at least 1 min. If the pressure rises no more than 0.01 kPa in that period, the apparatus is considered acceptable.

A6.3.2.2 Connect the reference (primary) vacuum gage(s) and the gage(s) to be calibrated to the manifold. The gages shall have such a range that the desired calibration pressure falls between 10 and 90 % of the scale. Insert a dry ice trap between the manifold and the vacuum pump. Adjust the pressure to the required level for the test and run a final leak test as above.

A6.3.2.3 After steady conditions have been maintained for at least 3 min, readings are made of all gages and compared with the reference gage.

A6.3.2.4 Repeat the above procedure at the other required pressure levels.

A6.3.2.5 Make up a chart of corrections to be added at each pressure level for each gage tested. This can be used for interpolation when necessary.

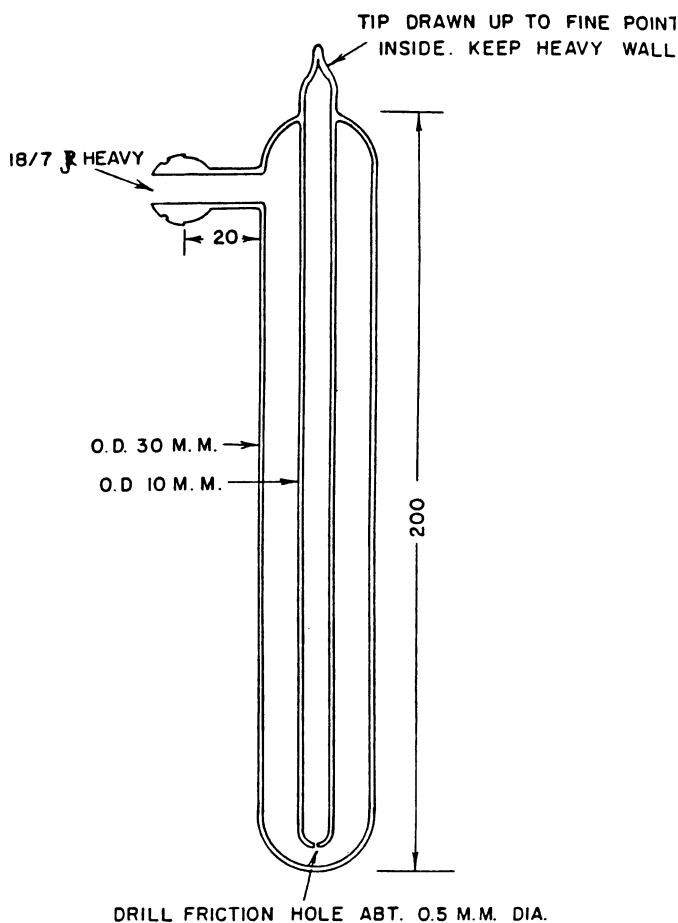

FIG. A6.3 Vacuum Manometer

A7. TEST METHOD FOR VERIFICATION OF REFLUX DIVIDING VALVES

A7.1 Scope

A7.1.1 This test method is for determining whether a liquid reflux dividing valve produces the prescribed reflux ratio.

A7.2 Summary of Test Method

A7.2.1 A hydrocarbon distillate of medium density is introduced to the reflux dividing valve while operating in the normal way. The reflux ratio is determined by the ratio of the two streams so obtained. The test is conducted over a range of rates normally encountered in use to ensure that performance is acceptable at all levels.

A7.3 Significance and Use

A7.3.1 This test method is intended to ensure that the valve in operation actually divides the reflux in the desired ratio.

A7.4 Apparatus

A7.4.1 The apparatus consists of the column and reflux divider with its controller and the condenser if necessary for convenient entry of liquid to the divider.

A7.4.2 A means must be provided for introducing the test liquid at steady rates over a range that includes 10 to 90 % of the maximum capacity of the column under test. This apparatus

can be a pumping system, but a simple gravity flow system can be used if its reservoir is of a capacity that will ensure relatively uniform rates for each test. A supply of 400-mL beakers tared to the nearest gram and a stopwatch are also required.

A7.5 Reagents and Materials

A7.5.1 The test liquid can be any hydrocarbon fraction in the kerosine to diesel oil range (150 to 300°C).

A7.6 Preparation of Apparatus

A7.6.1 Assemble the column in the normal way with the valve in place. Attach the condenser in its normal position if this will facilitate the introduction of the test liquid to the divider. Connect the control device to the liquid dividing valve.

A7.6.2 Set an untared beaker of suitable size under the bottom of the column and another under the takeoff point.

A7.6.3 Mount the liquid flow system so that the necessary range of flow rates can be provided.

A7.7 Procedure

A7.7.1 Start the valve and set the control device in such a way that the valve is open for not less than 4 s and not more

than 6 s, and closed for a period that is five times as long (5:1 ratio).

A7.7.2 Commence introduction of the test liquid to the valve at a rate equal to about 10 % of the maximum boilup rate for the column under test.

A7.7.3 After 2 min have elapsed, simultaneously replace the beakers under the column and under the takeoff point with tared beakers.

A7.7.4 At precise 5 min intervals, simultaneously replace those beakers with another pair of tared beakers. After three sets of tared beakers have been collected, return the untared beakers and shut off the flow of liquid.

A7.7.5 Weigh each of the tared beakers and obtain the mass of liquid in each to the nearest gram.

A7.7.6 Calculate the ratio of the mass of test liquid recovered in the beaker at the bottom of the column to that at the top of the column in each of the three 5-min tests.

A7.7.7 If the ratios so obtained are not consistent to within $\pm 5\%$, repeat A7.7.1 through A7.7.6.

A7.7.8 Repeat the sequence A7.7.1-A7.7.7 at flow rates equal to about 30, 60, and 90 % of the maximum boilup rates for the column under test.

A7.7.9 Repeat sequence A7.7.1-A7.7.7 for a valve operation in which the closed portion of the cycle is equal to two times the open period (2:1 ratio).

A7.7.10 When the actual reflux ratio differs by more than 10 % from the desired ratio, the valve is not acceptable and must be corrected. Fig. A7.1 illustrates graphically the test results of a typical valve of acceptable performance.

A7.8 Precision and Bias

A7.8.1 No statement is made concerning either the preci-

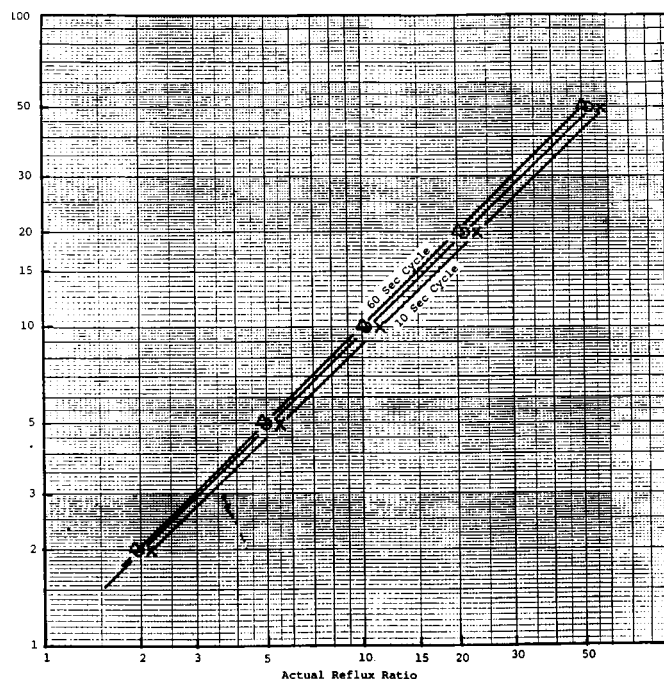

FIG. A7.1 Graphical Illustration of Actual Reflux Ratio of a Typical Reflux Divider

sion or bias of Annex A7 for checking the location of the temperature sensor because the result is used to determine whether there is conformance to the criteria stated in A7.7.10.

A8. PRACTICE FOR CONVERSION OF OBSERVED VAPOR TEMPERATURES TO ATMOSPHERIC EQUIVALENT TEMPERATURE (AET)

A8.1 Scope

A8.1.1 This practice is for the conversion of actual distillation temperatures at ambient and lower pressures to AET corresponding to 101.3 kPa (760 mm Hg) by means of equations derived by Maxwell and Bonnell.^{9,10}

A8.2 Significance and Use

A8.2.1 Table 3, Table 4, and Table 5 are based upon the same equations and may be used for pressures of 13.3 kPa (100 mm Hg), 1.33 kPa (10 mm Hg), and 0.266 kPa (2 mm Hg) respectively. Fig. 5 is provided only as a guide in estimating the cut points during distillation. Final data on AETs are to be obtained either from the tables or by computation.

A8.3 Calculation

A8.3.1 Convert observed vapor temperature to AET, using Eq A8.1.

$$AET = \frac{748.1A}{\frac{1}{T + 273} + 0.3861A - 0.00051606} - 273 \quad (A8.1)$$

where:

AET = atmospheric equivalent temperature, °C,

T = observed vapor temperature, °C,

$$A = \frac{5.143324 - 0.972546 \log P}{2579.329 - 95.76 \log P} \quad (A8.2)$$

P = pressure, between 0.27 and 101.3 kPa, or

$$A = \frac{5.994296 - 0.972546 \log P}{2663.129 - 95.76 \log P} \quad (A8.3)$$

P = pressure, between 2 and 760 mm Hg.

A8.3.2 The equations are correct only for fractions having a Watson K-factor of 12.0 ± 0.2 and boiling between 38 and 371°C. The K-factor shall be assumed to be 12 and any effect of K-factor ignored unless there is mutual agreement to the contrary.

A8.3.3 If correction is required, calculate the K-factor, using Eq A8.4:

⁹ Maxwell and Bonnell, *Industrial Engineering Chemistry*, Vol 49, 1957, p. 1187.

¹⁰ These equations are convenient versions of the equations published in Section 5A1.13 of the *API Technical Data Book*.

$$K = \frac{\sqrt[3]{1.8(B + 273)}}{D} \quad (\text{A8.4})$$

where:

B = mean average boiling point, °C, and

D = density at 15°C.

By custom, either the mid-vapor temperature of the fraction or the mid-point of a gas chromatographic distillation of the fraction can be used for the mean average boiling point. In either case the method must be specified.

A8.3.3.1 An estimate of the K -factor can be made using Fig. A8.1.

A8.3.4 Calculate the correction to be applied to the AET, using Eq A8.5:

$$t = -1.4[K - 12][\log(P_a/P_o)] \quad (\text{A8.5})$$

where:

t = correction, °C,

P_a = atmospheric pressure, kPa (mm Hg), and

P_o = observed pressure, kPa (mm Hg).

A8.3.4.1 An estimate of the correction can be made using Fig. A8.2.

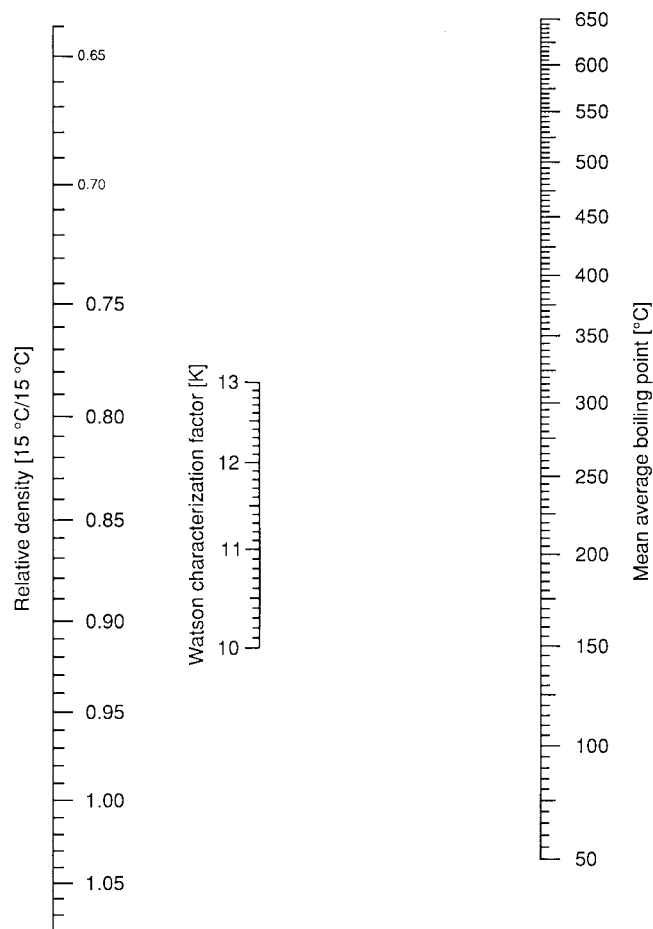

FIG. A8.1 Watson Characterization Factor of Petroleum Fractions

A9. PRACTICE FOR PERFORMANCE CHECK

A9.1 Scope

A9.1.1 The determination of efficiency can be made at any cut point where samples of two or more adjacent fractions can be analyzed by gas chromatography. Either fresh or stored samples can be analyzed as long as they have been protected from loss by evaporation. The samples must be wide enough that the overlap by GC analysis does not extend beyond the middle of the fraction. Uniform 100°C wide fractions are recommended. The minimum boiling range is 50°C.

A9.2 Referenced Documents

A9.2.1 ASTM Standards:

D 2887 Test Method for Boiling Range Distribution of Petroleum Fractions by Gas Chromatography⁵

D 3710 Test Method for Boiling Range Distribution of Gasoline and Gasoline Fractions by Gas Chromatography⁵

A9.3 Summary of Practice

A9.3.1 The cross contamination between the adjacent frac-

tions is calculated as the temperature at which the overlaps are equal on the basis of mass % of the charge. This is an empirical method and is done by trial and error to an accuracy of 0.5°C.

A9.4 Significance and Use

A9.4.1 Good agreement in yield of fractions can be achieved under a variety of conditions because efficiency has no measurable effect on yields except at the beginning and end of a distillation. However, fractions produced at high efficiency will have a narrower boiling range and hence some different properties than the same fraction made at low efficiency. Similarly, concentrations of aromatics, for instance, will be sharpened by high efficiency but are largely unnoticed at lower levels. To arrive at a standard level of efficiency, the following overall check is recommended in place of Annex A1 through Annex A5 inclusive and Annex A7. Calibrations prescribed in Annex A6 should be done routinely. If the results of this test (Annex A9) are unacceptable, then the foregoing annexes should be considered to determine the cause.

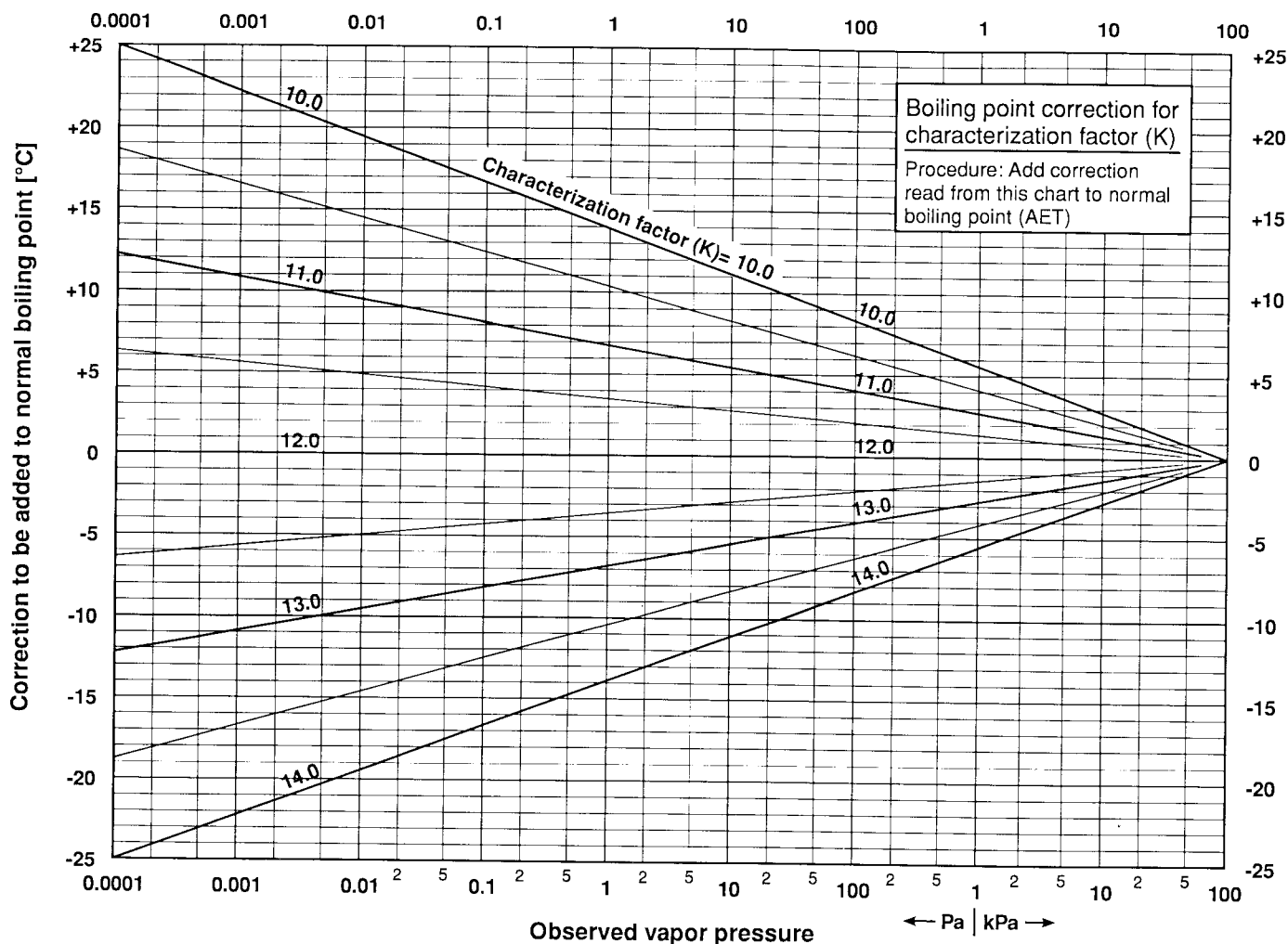

FIG. A8.2 Boiling Point Corrections for K-Factor

A9.4.2 A precise method for the calculation of efficiency at a cut point has been developed¹¹ and must be used in cases of dispute. A graphical solution by this method is included in Fig. A9.1.

A9.5 Procedure

A9.5.1 Obtain samples of at least two contiguous fractions from each level of pressure and analyze them according to Test

¹¹ Butler and Pasternak, *The Canadian Journal of Chemical Engineering*, Vol 42, 1964, p. 47.

Method D 2887 or D 3710, whichever is appropriate. Ensure that temperatures are printed in °C for every 1 % from 0 to 100 %. Obtain the yield of each fraction in mass % of the crude oil charged to the distillation.

A9.6 Calculation

A9.6.1 Select a temperature at the end of Fraction 1 that when converted to yield in mass % of the charge will approximate the yield in mass % of the charge of the front end of the next cut at the same temperature. Agreement must be as close as practical using steps of 0.5°C and interpolating when necessary.

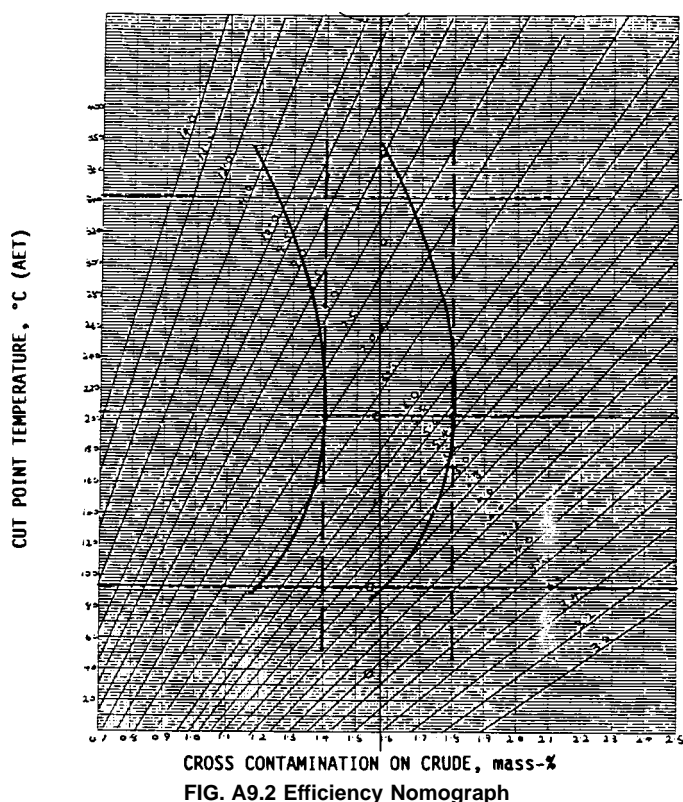

FIG. A9.2 Efficiency Nomograph

TABLE A9.1 Efficiency Standard 15/5 for Crudes from 25–40° API (tentative)

Cut Point °C	Standard Efficiency Theoretical Plates
50	5.4 + 1.0 – 0.6
100	5.5 + 0.9 – 0.8
150	5.6 + 0.8 – 0.7
200	6.2 + 0.9 – 0.8
250	6.8 + 0.9 – 0.6
300	7.7 + 1.1 – 0.9
350	9.0 + 1.5 – 1.2

may be adjusted. Fig. A9.2 is a graph of the limits shown.

APPENDIX

(Nonmandatory Information)

X1. PRACTICE FOR DEHYDRATION OF A SAMPLE OF WET CRUDE OIL

X1.1 Scope

X1.1.1 This practice is for dehydrating a sample of wet crude oil prior to fractional distillation.

X1.2 Summary of Test Methods

X1.2.1 A sufficient quantity of the sample is distilled in a low efficiency column under atmospheric pressure at zero reflux ratio (total takeoff) to 130°C, the water decanted, and dry components recombined.

X1.3 Significance and Use

X1.3.1 Dehydration is important in order to achieve accurate yields in the light naphtha region.

X1.4 Apparatus

X1.4.1 The dehydration of a sample of wet crude oil requires apparatus, such as that shown in Fig. 1, composed of:

X1.4.1.1 *Distillation flask*, with two side arms. In place of the differential pressure manometer in the second sidearm, a capillary is fitted for the passage of nitrogen into the liquid.

When a sample is suspected of containing emulsified water or significant amounts of clay or sediment, or both, additional risk to glass apparatus is involved. In this case, remove gross water and sediment and use a metal flask for dewatering.

X1.4.1.2 *Distillation Column*, shall be of the type described in 6.1.3.

X1.4.1.3 The rest of the apparatus is identical to that described in 6.1.

X1.5 Preparation of Apparatus

X1.5.1 Clean the distillation column and all the glassware before starting the test.

X1.6 Procedure

X1.6.1 Cool the charge to a temperature not lower than 0°C. Decant any bulk water that may be present. Weigh by difference to the nearest gram, into a chilled distillation flask containing some pieces of glass or porcelain, a given volume of wet crude oil.

X1.6.2 Attach the flask to the column and pass a slow stream of nitrogen (8 cm³/s) through the capillary. Vent the condenser through two traps in series maintained at the temperature of dry ice. Circulate coolant at a temperature of -20°C in the condensers.

X1.6.3 Apply heat to the flask, regulating it to attain a moderate reflux rate as specified in 9.2.4 to 9.2.8 for debutanization. Remove distillate slowly at total takeoff (reflux ratio = 0) until a vapor temperature of 130°C is reached. Collect the fraction distilling below 65°C in a receiver cooled to -20°C or lower.

X1.6.4 Shut off the reflux valve and the heating system. Cool the flask and contents to ambient temperature. Maintain

the traps at the temperature of dry ice. Weigh the distillate fractions obtained.

X1.6.5 To separate the water from each distillate fraction, cool to -5°C and decant the hydrocarbon liquid. Weigh the water.

X1.6.6 Remove the condenser and rinse it with alcohol or acetone to remove adhering drops of water. Dry with air and replace it.

X1.6.7 Recombine the cooled decanted fractions with the distillation residue observing the usual precautions against losses. Do not recombine the trap fraction.

X1.6.8 Record the quantity of dry oil recovered. If reblending of the dried fractions was done in the original flask, this flask can be used for subsequent distillation.

X1.7 Calculation

X1.7.1 Calculate the mass % of water using Eq X1.1.

$$W = 100(A/B) \quad (X1.1)$$

where:

A = mass of water recovered, g,

B = mass of charge, g,

W = Mass % of water, and

100 = percentage constant.

X1.8 Precision and Bias

X1.8.1 No statement is made concerning either the precision or bias of Appendix X1 for mass % water because the test method is used primarily for sample preparation for Test Method D 2892.

The American Society for Testing and Materials takes no position respecting the validity of any patent rights asserted in connection with any item mentioned in this standard. Users of this standard are expressly advised that determination of the validity of any such patent rights, and the risk of infringement of such rights, are entirely their own responsibility.

This standard is subject to revision at any time by the responsible technical committee and must be reviewed every five years and if not revised, either reapproved or withdrawn. Your comments are invited either for revision of this standard or for additional standards and should be addressed to ASTM Headquarters. Your comments will receive careful consideration at a meeting of the responsible technical committee, which you may attend. If you feel that your comments have not received a fair hearing you should make your views known to the ASTM Committee on Standards, at the address shown below.

This standard is copyrighted by ASTM, 100 Barr Harbor Drive, PO Box C700, West Conshohocken, PA 19428-2959, United States. Individual reprints (single or multiple copies) of this standard may be obtained by contacting ASTM at the above address or at 610-832-9585 (phone), 610-832-9555 (fax), or service@astm.org (e-mail); or through the ASTM website (www.astm.org).