

This document is not an ASTM standard and is intended only to provide the user of an ASTM standard an indication of what changes have been made to the previous version. Because it may not be technically possible to adequately depict all changes accurately, ASTM recommends that users consult prior editions as appropriate. In all cases only the current version of the standard as published by ASTM is to be considered the official document.



Designation: D 4423 – 91 (Reapproved 1996)



Standard Test Method for Determination of Carbonyls In C₄ Hydrocarbons¹

This standard is issued under the fixed designation D 4423; the number immediately following the designation indicates the year of original adoption or, in the case of revision, the year of last revision. A number in parentheses indicates the year of last reappraisal. A superscript epsilon (ε) indicates an editorial change since the last revision or reappraisal.

¹ This test method is under the jurisdiction of ASTM Committee ~~D-2~~ D02 on Petroleum Products and Lubricants and is the direct responsibility of Subcommittee D02.D0.04 on C₄ Hydrocarbons.

Current edition approved ~~March 15, 1991~~, Dec. 10, 2000. Published ~~July 1991~~, January 2001. Originally published as D 4423 – 84. Last previous edition D 4423 – 84 91(1996).

1. Scope

1.1 This test method covers the determination of carbonyls (ketones and aldehydes) in C₄ hydrocarbons. This test method was tested on polymerization-grade 1,3-butadiene.

1.2 The applicable range for this test method is 0 to 50 mg/kg carbonyls calculated as acetaldehyde.

1.3 Other C₄ hydrocarbons and their mixtures besides polymerization-grade 1,3-butadiene could be tested using this same test method. However, the precision section of this test method covers only carbonyls in applicable range as listed in 1.2, as found in polymerization-grade 1,3-butadiene.

1.4 The values stated in SI units are to be regarded as the standard.

1.5 *This standard does not purport to address all of the safety concerns, if any, associated with its use. It is the responsibility of the user of this standard to establish appropriate safety and health practices and determine the applicability of regulatory limitations prior to use.*

2. Referenced Documents

2.1 *ASTM Standards:*

D 484 Specification for Hydrocarbon Dry Cleaning Solvents²

D 1193 Specification for Reagent Water³

E 1 Specification for ASTM Thermometers⁴

3. Summary of Test Method

3.1 A measured amount of sample is added to an alcoholic hydroxylamine hydrochloride solution that has been adjusted to a given coloration using either alcoholic acid or base. The carbonyls will react with the hydroxylamine hydrochloride releasing an equivalent amount of hydrochloric acid which is then back-titrated to the original coloration. A blank containing only methanol and sample is titrated and the sample's results are calculated using the blank adjustment. Results are reported as milligrams per kilogram carbonyls as acetaldehyde.

4. Significance and Use

4.1 The determination of the carbonyl content of polymerization-grade 1,3-butadiene is necessary, since in some polymerization reactions, the presence of carbonyls in excess over some specified amount can have a deleterious effect upon the polymer properties or the reaction itself, or both.

5. Apparatus

5.1 *Bunsen Valves*—A device constructed so that when used with an Erlenmeyer flask, the sample vapors can exit the flask while protecting the flask's liquid contents. See Fig. 1 for details.

5.2 *Cooling Coil*—Prepare a cooling coil by winding about 10 to 15 cm of seamless copper tubing (about 6-mm diameter) on a short length of pipe (about 1.5 to 2.0-cm diameter), allowing sufficient length of tubing at the end of the coil to connect it to the sample source. Attach a valve at a point that would not extend more than 8 cm above the surface of the cooling bath liquid. To the valve, attach a 6 to 8 cm length piece of tubing bent downward so that the hydrocarbon liquid can be directed into the receiving container.

² Discontinued; see 1983 Annual Book of ASTM Standards, Vol. 05.01.

³ Annual Book of ASTM Standards, Vol 11.01

⁴ Annual Book of ASTM Standards, Vol 14.03.

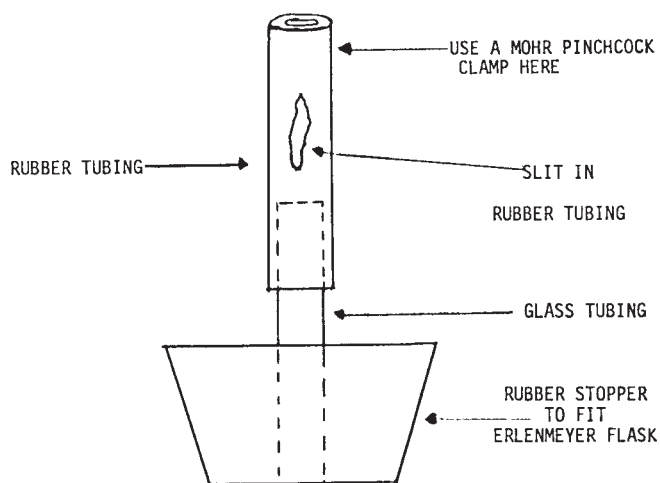

FIG. 1 Apparatus

5.3 *Dewar Flask*—The Dewar flask must be of sufficient volume to completely immerse the main portion of the cooling coil except for the extremities necessary for receiving and delivering the sample through the coil.

5.4 *Erlenmeyer Flasks*. 250-mL capacity.

5.5 *Volumetric Flasks*. 1-L capacity. These flasks should be Class A glassware.

5.6 *Graduated Cylinders*—100-mL capacity, glass cylinders, graduated in 1 or 2-mL divisions.

5.7 *Microburets*. 2.00 or 5.00-mL capacity. The microburets should be Class A glassware with 0.01 or 0.02-mL divisions or less. It is advisable to have the buret's tip end equipped with a syringe needle to dispense very small drops of titrant.

5.8 *Sample Cylinders*—These should be of sufficient volume to give the required amount of sample for testing. Stainless steel cylinders equipped with needle valves should be used. It is suggested that a 500-mL-capacity cylinder be the minimum size to be used for butadiene.

5.9 *Thermometer*—For observing temperatures below -45°C . The Low Cloud and Pour Point Thermometer, conforming to the requirements for ASTM Thermometer 6C, as prescribed in Specification E 1, is satisfactory. Thermometer 6C has a range from -80 to $+20^{\circ}\text{C}$.

6. Reagents and Materials

6.1 *Purity of Reagents*—Reagent grade chemicals should be used in all tests. Unless otherwise indicated, it is intended that all reagents conform to the specifications of the Committee on Analytical Reagents of the American Chemical Society where such specifications are available.⁵ Other grades may be used, provided it is first ascertained that the reagent is of sufficiently high purity to permit its use without lessening the accuracy of the determination.

6.2 *Purity of Water*—Unless otherwise indicated, references to water shall be understood to mean Type II reagent water conforming to Specification D 1193.

6.3 *Alcoholic Hydrochloric Acid (0.05 N)*—Dilute 4.2 mL of concentrated hydrochloric acid (**Warning—See Note 1**)—**Poison. Corrosive. May be fatal if swallowed. Liquid and vapor cause severe burns. Harmful if inhaled.** to volume with anhydrous methanol in a 1-L volumetric flask. Use the alcoholic 0.05 N potassium hydroxide solution to standardize the HCl solution. Note 1—**Warning: Poison Corrosive. May be fatal if swallowed. Liquid and vapor cause severe burns. Harmful if inhaled.**

6.4 *Alcoholic Hydroxylamine Hydrochloride*—Dissolve 35.0 g of hydroxylamine hydrochloride (**Warning—See Note 2**) in 3.5 L of anhydrous methanol. (**Warning—See Note 3.**)

Note 2—**Warning: May**—May be irritating to skin, eyes, or mucous membranes. Harmful if inhaled.

Note 3—**Warning: Flammable; inhaled.** in 3.5 L of anhydrous methanol. (**Warning—Flammable. Vapor harmful. May be fatal or cause blindness if swallowed or inhaled. Cannot be made nonpoisonous.**)

6.5 *Alcoholic Potassium Hydroxide (0.05 N)*—Dissolve 3.3 g of potassium hydroxide in anhydrous methanol. (**Warning—See Note 4.**) Make to volume with methanol in a 1-L volumetric flask. Standardize against a primary standard, potassium acid phthalate.

Note 4—**Warning: Corrosive.**—Corrosive. Can cause severe burns or blindness. Evolution of heat produces a violent reaction or eruption upon too rapid mixture with water.) Make to volume with methanol in a 1-L volumetric flask. Standardize against a primary standard, potassium acid phthalate.

⁵ *Reagent Chemicals, American Chemical Society Specifications*, American Chemical Society, Washington, DC. For suggestions on the testing of reagents not listed by the American Chemical Society, see *Analar Standards for Laboratory Chemicals*, BDH Ltd., Poole, Dorset, U.K., and the *United States Pharmacopeia and National Formulary*, U.S. Pharmacopeial Convention, Inc. (USPC), Rockville, MD.

6.6 *Dry Ice (Carbon Dioxide Solid)*—(Warning—See Note 5.)

~~NOTE 5—Warning: Extremely—Extremely cold (–78.5°C). Liberates heavy gas which may cause suffocation. Contact with skin causes burns or freezing, or both. Vapors may react violently with hot magnesium or aluminum alloys.)~~

6.7 *Stoddard Solvent*—Conforming to the specification listed in Specification D 484. (Warning—See Note 6.)

~~NOTE 6—Warning: Combustible.—Combustible. Vapor harmful.)~~

6.8 *Thymol Blue Indicator*—Dissolve 0.04 g of thymol blue in 100 mL of anhydrous methanol. (Warning—See Note 3.)
—Flammable. Vapor harmful. May be fatal or cause blindness if swallowed or inhaled. Cannot be made nonpoisonous.)

7. Preparation of Apparatus

7.1 *Dry Ice-Stoddard Solvent Bath*— Add a sufficient quantity of Stoddard solvent into the Dewar flask to ensure that the cooling coil will be submerged in the liquid plus dry ice (solid CO₂). (Warning—See Note 5 6.6 and Note 6.) 6.7.) Carefully add sufficient dry ice to the Stoddard solvent to obtain a temperature of at least – 50°C. (Warning—See Note 7.)—Great care must be taken during this step. Do not add the dry ice all at once, but in small pieces, especially at the beginning. Wear protective gloves and adequate eye protection to prevent any contact with the extremely cold materials.) Attach the sample cylinder containing the butadiene (Warning—See Note 8.)—Extremely flammable gas under pressure. May form explosive peroxides upon exposure to air. Harmful if inhaled. Irritating to eyes, skin, and mucous membranes.) to the cooling coil and immerse the coil into the liquid. Support the sample cylinder in a cylinder rack or using a ring stand and appropriate clamps. Be sure the coil is positioned so that the delivery tip is free to dispense liquid butadiene into the Erlenmeyer flasks. After each use, be sure to clean the coil's interior with methanol. DO NOT USE ACETONE. NOTE 7—Warning: Great care must be taken during this step. Do not add the dry ice all at once, but in small pieces, especially at the beginning. Wear protective gloves and adequate eye protection to prevent any contact with the extremely cold materials.

~~NOTE 8—Warning: Extremely flammable gas under pressure. May form explosive peroxides upon exposure to air. Harmful if inhaled. Irritating to eyes, skin, and mucous membranes.~~

8. Procedure

8.1 Prepare a sample flask by pouring 50 mL of alcoholic hydroxylamine hydrochloride into a 250-mL Erlenmeyer flask.

8.2 Prepare a flask for use as a sample blank by pouring 50 mL of methanol into a 250-mL Erlenmeyer flask.

8.3 Add about 0.5 mL of thymol blue indicator solution to each flask.

8.4 Carefully add 0.05 N alcoholic KOH or alcoholic HCl to each flask until matching colors are obtained. The desired color is a yellow color with a slight, but distinct, orange coloration. It is important that this orange color is present at this point of the test. If the color is more yellow at this point, it would be easy to obtain a result of less than 1 mg/kg carbonyls on a sample containing over 100 mg/kg of carbonyls.

8.5 Stopper the flasks with the Bunsen valves. (This keeps the CO₂ vapor out of the flasks). Set the flasks on some crushed dry ice for a few minutes to cool the liquid contents. The color in the flasks may turn more yellow when cold, but this is not significant at this point. From this step forward, all operations must be carried out in a well-ventilated hood.

8.6 Cool a 100-mL graduated cylinder by holding it in the cooling bath for a few seconds. Then, when it is cold, collect 100 ± 1 mL butadiene into the graduated cylinder. Quickly, using a clean thermometer, measure the sample's temperature to the nearest 1°C. Record this temperature as "T" for use later to obtain the sample weight. Pour this sample into the sample flask containing the alcoholic hydroxylamine hydrochloride solution. Replace the Bunsen valve on the flask and set aside. Again, collect 100 ± 1 mL of sample into the graduated cylinder. Pour this sample into the sample blank flask containing only the methanol. Replace the Bunsen valve and set aside.

8.7 Sample and sample blank can be titrated after 15 min while cold butadiene is in the flasks. If done, be careful to avoid vigorous agitation because some of the contents may boil over and be lost. It is advisable to allow as much of the butadiene as possible to evaporate before titration begins.

8.8 Titrate the sample flask's contents back to the original coloration, as described in 8.4, by using the alcoholic KOH. Record this value as "A." Set the flask aside in the hood for 5 min before pouring out the contents. If it turns red, the carbonyl concentration may be high or there is contamination in the flask. Continue the titration until the flask's contents will not turn red after standing 5 minutes.

8.9 Titrate the sample blank flask's contents. If the solution is red, use the standard KOH solution. If it is yellow, use the standard HCl solution. In either case, unless the sample blank's contents are still at the original coloration, titrate with the appropriate titrant back to the same, original coloration as described in 8.4. Record this value as "E."

9. Calculation

9.1 Calculate as follows when the sample has no free acid or free base:

mg/Kg carbonyls (as acetaldehyde)

$$= A \times Nb \times 44050 / V \times D \quad (1)$$

where:

- A = alcoholic KOH titration, mL,
- Nb = normality of KOH solution,
- V = sample volume, mL, and
- D = butadiene density at temperature T (found by using Table 1).

9.2 Calculate as follows when the sample has free acid:

$$\begin{aligned} &\text{mg/Kg carbonyls (as acetaldehyde)} \\ &= (A - Bb) \times Nb \times 44050 / V \times D \end{aligned} \quad (2)$$

where

- Bb = alcoholic KOH used for the sample blank, mL.

9.3 Calculate as follows when the sample has free base:

$$\begin{aligned} &\text{mg/Kg carbonyls (as acetaldehyde)} \\ &= ((A \times Nb) \times (Ba \times Na)) \times 44050 / V \times D \\ &= ((A \times Nb) + (Ba \times Na)) \times 44050 / V \times D \end{aligned} \quad (3)$$

where:

- Na = normality of alcoholic HCl
- Ba = alcoholic HCl used for the sample blank, mL

10. Precision and Bias

10.1 *Precision*—The precision of this test method as determined by statistical examination of interlaboratory results is as follows:

10.1.1 *Repeatability*—The difference between two test results obtained by the same operator with the same apparatus under constant operating conditions on identical test material would, in the long run, in normal and correct operation of the test method, exceed the following value in only one case in twenty, where X = the average of the two test results:

$$14 \% \text{ of } X$$

10.2 *Reproducibility*—The difference between two single and independent results obtained by different operators working in different laboratories on identical test material would, in the long run, in the normal and correct operation of the test method, exceed the following value in only one case in twenty, where X = average of two test results:

$$88 \% \text{ of } X$$

10.3 *Bias*—Since there is no accepted reference material for determining the bias for the procedure in this test method for measuring carbonyls, no statement on bias is being made.

11. Keywords

11.1 butadiene; C_4 hydrocarbons; carbonyls; titration

ASTM International takes no position respecting the validity of any patent rights asserted in connection with any item mentioned in this standard. Users of this standard are expressly advised that determination of the validity of any such patent rights, and the risk of infringement of such rights, are entirely their own responsibility.

This standard is subject to revision at any time by the responsible technical committee and must be reviewed every five years and if not revised, either reapproved or withdrawn. Your comments are invited either for revision of this standard or for additional standards and should be addressed to ASTM International Headquarters. Your comments will receive careful consideration at a meeting of the responsible technical committee, which you may attend. If you feel that your comments have not received a fair hearing you should make your views known to the ASTM Committee on Standards, at the address shown below.

TABLE 1 Density of Butadiene at Various Temperatures

NOTE 1—These data may be used in a graphical manner for better interpolation between data points.

Temperature, °C	Density, g/mL
-45	0.6958
-40	0.6903
-35	0.6848
-30	0.6793
-25	0.6737
-20	0.6681
-15	0.6625
-10	0.6568
-5	0.6510
0	0.6452

This standard is copyrighted by ASTM International, 100 Barr Harbor Drive, PO Box C700, West Conshohocken, PA 19428-2959, United States. Individual reprints (single or multiple copies) of this standard may be obtained by contacting ASTM at the above address or at 610-832-9585 (phone), 610-832-9555 (fax), or service@astm.org (e-mail); or through the ASTM website (www.astm.org).