



Standard Test Method for Oxidation Stability of Gasoline Automotive Engine Oils by Thin-Film Oxygen Uptake (TFOUT)¹

This standard is issued under the fixed designation D 4742; the number immediately following the designation indicates the year of original adoption or, in the case of revision, the year of last revision. A number in parentheses indicates the year of last reapproval. A superscript epsilon (ϵ) indicates an editorial change since the last revision or reapproval.

1. Scope

1.1 This test method evaluates the oxidation stability of engine oils for gasoline automotive engines. This test, run at 160°C, utilizes a high pressure reactor pressurized with oxygen along with a metal catalyst package, a fuel catalyst, and water in a partial simulation of the conditions to which an oil may be subjected in a gasoline combustion engine. This test method can be used for engine oils with viscosity in the range from 4 mm²/s (cSt) to 21 mm²/s (cSt) at 100°C, including re-refined oils.

1.2 This test method is not a substitute for the engine testing of an engine oil in established engine tests, such as Sequence IIID.

1.3 The values stated in SI units are to be regarded as the standard. The values given in parentheses are provided for information purposes only.

1.4 This standard does not purport to address all of the safety concerns, if any, associated with its use. It is the responsibility of the user of this standard to establish appropriate safety and health practices and determine the applicability of regulatory limitations prior to use. For specific warning statements, see Sections 7 and 8.

1.4 ~~The values stated in SI units are to be regarded as the standard. The values given in parentheses are provided for information purposes only.~~

2. Referenced Documents

2.1 ASTM Standards:

A 314 Specification for Stainless Steel Billets and Bars for Forging²

¹ This test method is under the jurisdiction of ASTM Committee D02 on Petroleum Products and Lubricants and is the direct responsibility of Subcommittee D02.09 on Oxidation.

Current edition approved ~~Feb~~ April 10, 2002. Published ~~April~~ July 2002. Originally published as D 4742–88. Last previous edition ~~D 4742–96~~; D 4742–02.

- B 211 Specification for Aluminum and Aluminum-Alloy Bar, Rod, and Wire³
- D 664 Test Method for Acid Number of Petroleum Products by Potentiometric Titration⁴
- D 1193 Specification for Reagent Water⁵
- D 2272 Test Method for Oxidation Stability of Steam-Turbine Oils by Rotating-Bomb Pressure Vessel⁴
- D 4057 Practice for Manual Sampling of Petroleum and Petroleum Products⁶
- E 1 Specification for ASTM Thermometers⁷
- ~~E 144 Practice for Safe Use of Oxygen Combustion Bombs⁸~~

3. Terminology

3.1 Definitions of Terms Specific to This Standard:

- 3.1.1 *break point*—the precise point of time at which rapid oxidation of the oil begins.
- 3.1.2 *oxidation induction time*—the time until the oil begins to oxidize at a relatively rapid rate as indicated by the decrease of oxygen pressure.
- 3.1.3 *oxygen uptake*—oxygen absorbed by oil as a result of oil oxidation.

4. Summary of Test Method

4.1 The test oil is mixed in a glass container with three other liquids that are used to simulate engine conditions: (1) an oxidized/nitrated fuel component (Annex A2), (2) a mixture of soluble metal naphthenates (lead, copper, iron, manganese, and tin naphthenates (Annex A3)), and (3) Type II reagent water.

4.2 The glass container holding the oil mixture is placed in a high pressure reactor equipped with a pressure gage. The high pressure reactor is sealed, charged with oxygen to a pressure of 620 kPa (90 psig), and placed in an oil bath at 160°C at an angle of 30° from the horizontal. The high pressure reactor is rotated axially at a speed of 100 r/min forming a thin film of oil within the glass container resulting in a relatively large oil-oxygen contact area.

NOTE 1—A pressure sensing device can be used in place of a pressure gage.

4.3 The pressure of the high pressure reactor is recorded continuously from the beginning of the test and the test is terminated when a rapid decrease of the high pressure reactor pressure is observed (Point B, Fig. A1.2). The period of time that elapses between the time when the high pressure reactor is placed in the oil bath and the time at which the pressure begins to decrease rapidly is called the oxidation induction time and is used as a measure of the relative oil oxidation stability.

5. Significance and Use

5.1 This test method is used to evaluate oxidation stability of lubricating base oils with additives in the presence of chemistries similar to those found in gasoline engine service. Test results on some ASTM reference oils have been found to correlate with sequence IIID engine test results in hours for a 375 % viscosity increase.⁸ The test does not constitute a substitute for engine

² Annual Book of ASTM Standards, Vol 01.03.

³ Annual Book of ASTM Standards, Vol 02.02.

⁴ Annual Book of ASTM Standards, Vol 05.01.

⁵ Annual Book of ASTM Standards, Vol 11.01.

⁶ Annual Book of ASTM Standards, Vol 05.02.

⁷ Annual Book of ASTM Standards, Vol 14.03.

~~Annual Book~~

⁸ Ku, C. S. and Hsu, S. M., "A Thin Film Uptake Test for the Evaluation of ASTM Standards Automotive Lubricants," *Lubrication Engineering*, Vol 14.02; 40, 2, 1984, pp. 75-83.

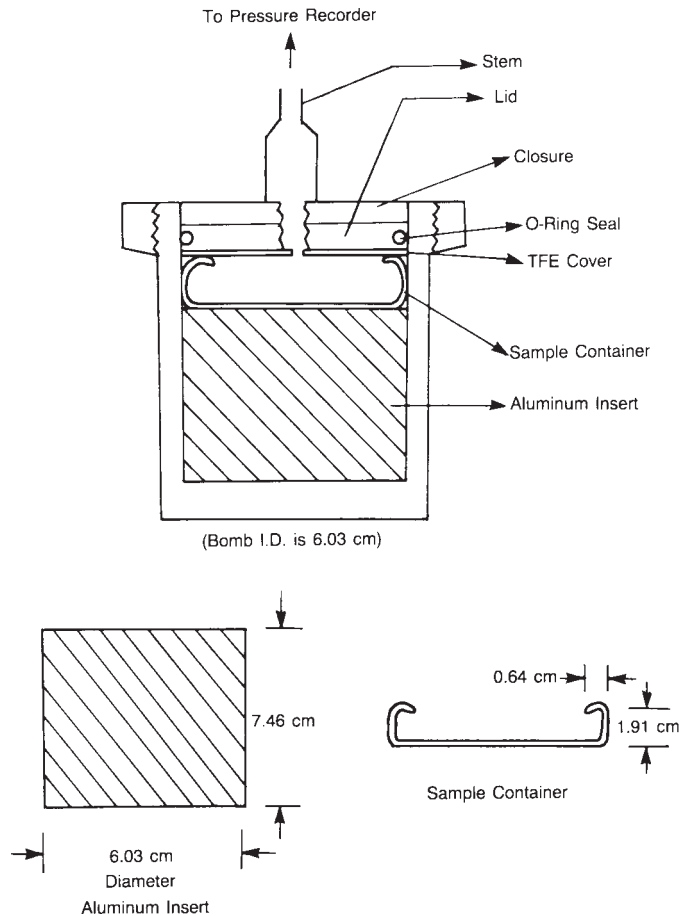

FIG. 2.1 Schematic Drawing of Oxidation Test Apparatus

testing, which measures wear, oxidation stability, volatility, and deposit control characteristics of lubricants. Properly interpreted, the test may provide input on the oxidation stability of lubricants under simulated engine chemistry.

5.2 This test method is intended to be used as a bench screening test and quality control tool for lubricating base oil manufacturing, especially for re-refined lubricating base oils. This test method is useful for quality control of oxidation stability of re-refined oils from batch to batch.

5.3 This test method is useful for screening formulated oils prior to engine tests. Within similar additive chemistry and base oil types, the ranking of oils in this test appears to be predictive of ranking in engine tests. When oils having completely different additive chemistry or base oil type are compared, oxidation stability results may not reflect the actual engine test result.

5.4 Other oxidation stability test methods have demonstrated that soluble metal catalyst supplies are very inconsistent and they have significant effects on the test results. Thus, for test comparisons, the same source and same batch of metal naphthenates shall be used.

NOTE 2—It is also recommended as a good research practice not to use different batches of the fuel component in test comparisons.

6. Apparatus

6.1 *High Pressure Reactor*, glass sample container, aluminum insert, pressure gage, thermometer, test bath and accessories are shown in Fig. 2.1 and Fig. 3.2 and described in Annex A1.

NOTE 3—It is reported in literature⁸ that the oxidation high pressure reactor can be modified from the Test Method D 2272 oxidation high pressure reactor by insertion of an aluminum cylinder.

6.2 *Precision Pressure Gage*—A certified precision pressure gage is used to accurately control the oxygen feed to the high pressure reactor. The gage has a sufficient range to encompass 0 to 650 kPa or more (~ 90 psig) required by the test method with division 2.0 kPa (~ 0.5 psig) or better to enable readings to be made to 2.0 kPa (~ 0.25 psig).

7. Reagents

7.1 *Purity of Reagents*—Reagent grade chemicals shall be used in all tests. Unless otherwise indicated, it is intended that all

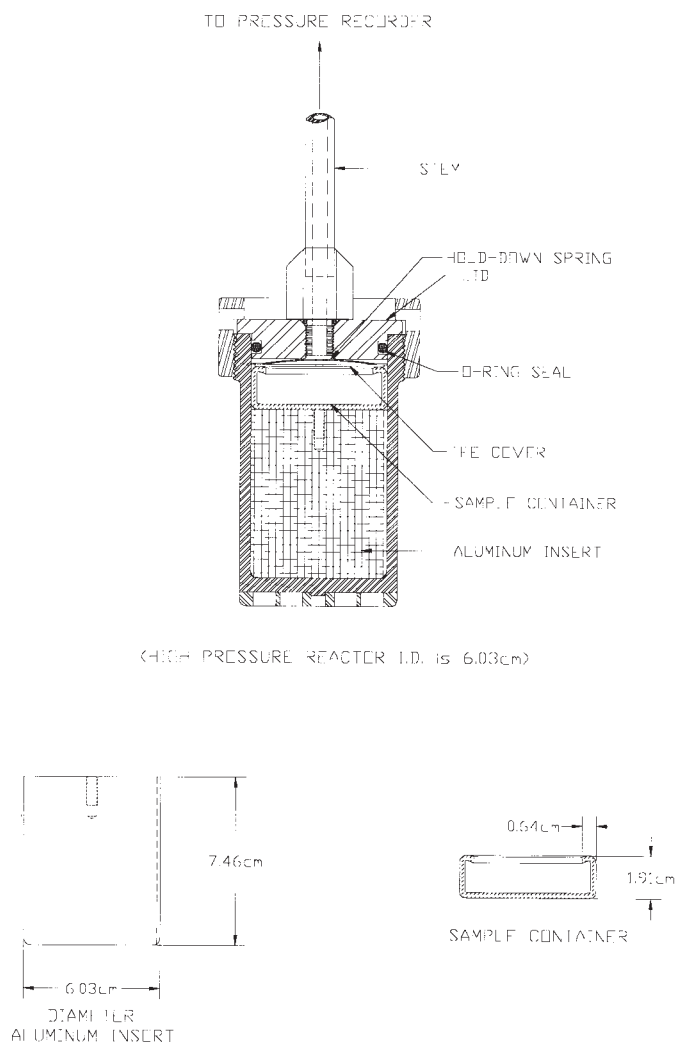

FIG. 3 2 Schematic Drawing of an Assembled Bomb, Aluminum Insert, and Glass Sample Container

reagents shall conform to the specifications of the Committee on Analytical Reagents of the American Chemical Society.⁹

7.2 *Purity of Water*—Unless otherwise indicated, references to water shall be understood to mean distilled water meeting requirements of reagent water as defined by Type I of Specification D 1193.

7.3 *Acetone*, CH_3COCH_3 . (**Warning**—Extremely flammable. Irritating to skin, eyes, and mucous membranes.)

7.4 *Air*, containing 2000 ppm nitrogen dioxide, NO_2 (commercially available compressed gas mixture, certified within $\pm 5\%$). (**Warning**—Nitrogen dioxide is poisonous.)

7.5 *Hexane*, C_6H_{14} , Practical Grade or other suitable hydrocarbon solvent. (**Warning**—Extremely flammable. Harmful if inhaled. May produce nerve cell damage. Skin irritant on repeated contact. Aspiration hazard.)

7.6 *Isopropyl Alcohol*, $\text{CH}_3\text{CH}(\text{CH}_3)\text{OH}$. (**Warning**—Flammable. Eye irritant. Vapors narcotic.)

7.7 *Oxygen*. (**Warning**—Oxygen vigorously accelerates combustion.)

7.8 *Potassium Hydroxide*, Alcohol Solution (1.5%)—Dissolve 12 g of potassium hydroxide (KOH) pellets in 1 L of 99% isopropyl alcohol. (**Warning**—Potassium hydroxide is corrosive.)

8. Materials

8.1 *Fuel Component*—The fuel component is an oxidized nitrated gasoline fraction. This component may be prepared in accordance with the procedures described in Annex A2. (See 8.2 and Note 4.) (**Warning**—Fuel component is extremely flammable. Vapors harmful if inhaled. Skin irritant on repeated contact. Aspiration hazard.)

⁹ Ku, C. S. and Hsu, S. M., "A Thin Film Uptake Test for

⁹ *Reagent Chemicals, American Chemical Society Specifications*, American Chemical Society, Washington, DC. For suggestions on the evaluation testing of Automotive Lubricants, reagents not listed by the American Chemical Society, see *Lubrication Engineering Analytical Standards for Laboratory Chemicals*, 40, 2, 1984, pp. 75-83. BDH Ltd., Poole, Dorset, U.K., and the United States Pharmacopeia and National Formulary, U.S. Pharmacopeial Convention, Inc. (USPC), Rockville, MD.

8.2 *Soluble Metal Catalyst Mixture*— This catalyst is a mixture of soluble metal catalysts (lead, copper, iron, manganese, and tin). The catalyst may be prepared according to the procedures described in Annex A3. (See 8.2 and Note 4.) (**Warning**—Lead and manganese naphthenates are known to be poisonous, but all naphthenates should be handled with care. Naphthenates are also flammable.)

NOTE 4—With some catalyst chemicals, reactivity can be a problem. This can be curtailed by storing in a refrigerator at approximately 5°C.

NOTE 5—It is recommended that each new batch of fuel or metal catalyst be correlated with a standard reference oil, in accordance with good laboratory practices.

8.3 *Liquid Detergent (Industrial Strength)*.

8.4 *Silicone Stopcock Grease*.

9. Preparation of Apparatus

9.1 *Glass Sample Container*—Rinse the glass sample container with hexane or other suitable hydrocarbon solvent. Clean the glass container with hot detergent solution and water. Rinse the container with acetone. Blow the container dry with clean compressed air.

NOTE 6—A clean glass sample container is important for obtaining repeatable results. Thorough cleaning of the glass sample can be accomplished by (1) hexane rinse, (2) acetone soak for 15 min, (3) hot detergent solution and water soak for 4 h, (4) acetone rinse, and (5) hexane rinse. A clean glass sample container is important for obtaining repeatable results.

NOTE 7—A segmented glass sample container has been found suitable to prevent premature mixing of the catalyst components.

9.2 *Cleaning of High Pressure Reactor*— Wash the inside of the high pressure reactor, aluminum insert, lid, and inside with hot detergent solution and water. Rinse the inside of the stem with isopropyl alcohol and blow dry with clean compressed air. If the high pressure reactor, insert, lid, or inside of the stem emits acidic odor after simple cleaning, wash with 1.5 % alcoholic potassium hydroxide (KOH) solution, and repeat the cleaning procedures.

9.3 *Cleaning of High Pressure Reactor Stem*—It is recommended to periodically disassemble, inspect, and clean the high pressure reactor stem. Rinse the inside of the stem with isopropyl alcohol and blow dry with clean compressed air. After cleansing, it is recommended to insert a dry pipe cleaner into the transducer line opening for removal of potential residue buildup.

NOTE 8—It is recommended to replace the O-rings when reassembling the pressure transducers.

9.4 To obtain a representative sample of stocks of uniform petroleum products, follow Practice D 4057.

9.5 *Cleaning of Catalyst Syringes*— Individual catalyst syringes are to be used for each catalyst component. They are to be thoroughly cleaned and dried prior to each use. (See Annex A4 for recommended procedure.)

10. Procedure

10.1 *Weighing and Mixing Sample and Catalyst Components*:

10.1.1 Weigh the clean glass sample container to the nearest mg.

10.1.2 Weigh 1.500 ± 0.001 g of oil sample into the container.

10.1.3 Add 0.060 ± 0.001 g each of both the fuel component and the soluble metal catalyst mixture.

10.1.4 Add 0.030 ± 0.001 g of distilled water to the glass sample container.

10.1.5 Just prior to inserting the glass sample container into the high pressure reactor, thoroughly mix the catalyst components within the sample container by hand-rotation (approximately five rotations) and proceed immediately to 10.2. Delay may result in variation of results.

10.2 *High Pressure Reactor Charging and Assembly*—Immediately and rapidly assemble the high pressure reactor as shown in Fig.-2-1.

10.2.1 Put the aluminum insert into the high pressure reactor followed by the glass sample container and the TFE (tetra-fluoroethylene) plastic cover disk.

10.2.2 Place the stainless hold-down spring on top of the TFE disk and the glass sample container.

NOTE 9—The stainless steel hold-down spring not only holds down the TFE cover disk but, more importantly, prevents the glass sample container from slipping inside the high pressure reactor with consequent poor results.

10.2.3 Apply a thin coating of silicone stopcock grease to the O-ring high pressure reactor seal located in the gasket groove of the high pressure reactor lid to provide lubrication.

10.2.4 Insert the lid into the high pressure reactor.

10.2.5 Place and tighten the cap on the high pressure reactor to lock down the lid in the high pressure reactor.

10.2.6 Attach the high pressure oxygen hose and purge the high pressure reactor twice at about 620 kPa (90 psig) of oxygen to remove the air originally present in the high pressure reactor.

NOTE 10—It is advisable to avoid releasing the oxygen too rapidly by decreasing the pressure to atmospheric in no less than one minute to avoid possible foaming and overflow of the sample from the glass sample container.

10.2.7 Charge the high pressure reactor to 620 kPa (90 psig) oxygen at 21°C using an in-line precision pressure gage to monitor the high pressure reactor pressure with 1 kPa (0.12 psig). (For ambient temperatures other than 21°C, increase (or decrease) the initial pressure by 2.5 kPa (0.4 psig) for each 1°C above (or below) 21°C.)

10.2.8 Fill the high pressure reactor to the required pressure and close the inlet valve. Test the high pressure reactor for leaks by immersing in water or by using soap solution.

10.3 Oxidation—Before starting the test, bring the heating bath to the test temperature at 160°C while the stirrer is in operation. (This can be done during preparation of the sample and the high pressure reactor.)

10.3.1 Switch off the stirrer and insert the high pressure reactor into the carriages. Note the time, and restart the stirrer.

~~10.3.2 If an auxiliary heater is used, keep it on for the first 5 min of the run and then turn it off (Note 10).~~

NOTE 11—The time for the bath to reach the operating temperature after insertion of the high pressure reactor may differ for different apparatus assemblies and should be observed for each unit (a unit may carry one, two, three, or four high pressure reactors). The objective is to find a set of conditions which does not permit a drop of more than 2°C after insertion of the high pressure reactor(s) and allows the high pressure reactor pressure to reach plateau within 15 min.

~~10.3.2 If an auxiliary heater is used, keep it on for the first 5 min of the run and then turn it off (Note 11).~~

10.3.3 Allow the bath temperature to level out at the test temperature which must occur within 15 min after insertion of the high pressure vessel. Maintaining the test temperature within the specified limits of 160°C ± 0.3°C during the entire test run is the most important single factor assuring both repeatability and reproducibility of test results. If the test temperature cannot be maintained as specified, the test results should not be considered valid.

10.4 Keep the high pressure reactor completely submerged and maintain continuous and uniform rotation throughout the test. A standard rotational speed of 100 ± 5 r/min is required; any appreciable variations in this speed could cause erratic results.

10.5 Monitor the pressure of the high pressure reactor. If a dial pressure gage is used, make readings at least every 5 min. (The maximum pressure must be reached within 15 min.) After a test period (the induction time), the pressure decreases because of oxygen absorption by oil (the break point).

10.5.1 When the oil reaches the break point, the pressure decreases rapidly. The test can be terminated as soon as sufficient information has been collected to form a tangent to the decreasing pressure trace (see 10.6) or, if desired, continued until pressure decreases to some further level.

NOTE 12—The pressure within the high pressure reactor increases at the beginning because of gas expansion accompanying the temperature increase of the high pressure reactor. Following this rise, the pressure reaches a plateau as shown in Fig. 3.2. This pressure may gradually drop slightly during the test. A gradual decrease of the pressure is not unusual and does not invalidate the test.

NOTE 13—If a break in pressure does not occur within 300 to 500 mins, the operator may elect to terminate the test. A slow decrease in pressure may result from a leak in the reactor or a very gradual oxidation process.

10.6 Record the time at which the pressure starts to decrease rapidly at the break point (Point B, Fig. A1.2), which is marked as the intersection of the tangent of the pressure plateau line during the final 20 min before the break point and the tangent of the pressure decrease line following the break point as shown in Fig. 4.3.

11. Report

11.1 Report the oxidation induction time in min. Determine the induction time as the time period from the beginning of the test (Point A, Fig. A1.2) to the break point (Point B, Fig. A1.2).

12. Precision and Bias

12.1 The precision of this test method, as determined by statistical examination of interlaboratory results on break point time, is as follows:

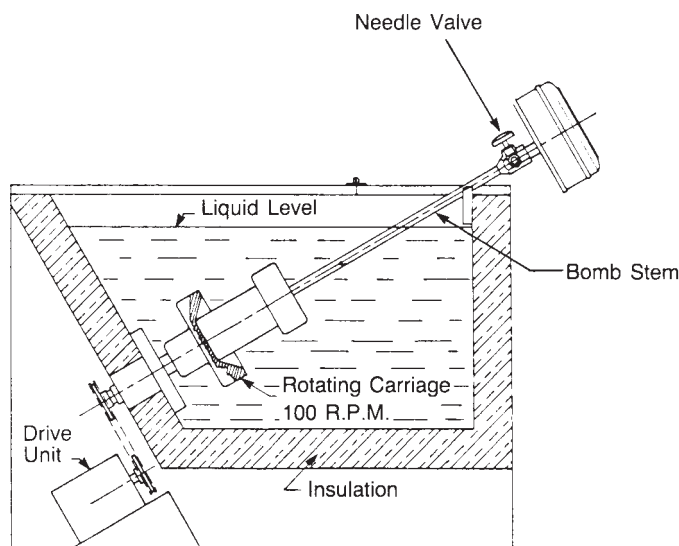

FIG. 1.3 Pressure versus Time Diagram of the Oxidation Test

12.1.1 *Repeatability*—The difference between successive results, obtained by the same operator with the same apparatus under constant operating conditions on identical test material, would in the long run, in the normal and correct operation of the test method, exceed the following values only in one case in twenty:

$$0.10 (x + 5 \text{ min}) \quad (1)$$

where: x is the mean replicate runs in min.

12.1.2 *Reproducibility*—The difference between two single and independent results obtained by different operators working in different laboratories on identical test material would, in the long run, in the normal and correct operation of the test method, exceed the following values only in one case in twenty:

$$0.22 (x + 5 \text{ min}) \quad (2)$$

where: x is the mean of results obtained, in min, by two different laboratories.

12.2 *Bias*—A bias statement is being developed.

12.3 The precision statements in 12.1.2¹ and 12.1.3² were determined from an interlaboratory study using the same batch of soluble metal mixture (Standard Reference Material SRM 1817 of the NIST) (see Note 14).

NOTE 14—The mixture was prepared using metal naphthenates from the specified batch number of the supplier: lead naphthenate (#101882),¹⁰ ferric naphthenate (#7124),¹⁰ cupric naphthenate (#72775),¹⁰ manganese naphthenate (#25296),¹⁰ and stannous naphthenate (#32519-A).¹¹

NOTE 15—The supporting test data from five cooperating laboratories are shown in Appendix X1. A research report (file No. RR: D02-1202) including the raw data and the statistical treatment of data is available upon request from ASTM International Headquarters, available.¹²

13. Keywords

13.1 oxidation stability; oxygen uptake; sequence IID engine simulation; TFOUT

~~Reagent Chemicals, American Chemical Society Specifications, American Chemical Society, Washington, DC. For suggestions on~~

~~¹⁰ The sole source of supply of lead naphthenate (#101882), ferric naphthenate (#7124), cupric naphthenate (#72775), and manganese naphthenate (#25296) known to the committee at this time is Pfaltz & Bauer, Inc., Stamford, CT. If you are aware of reagents not listed by alternative suppliers, please provide this information to ASTM International Headquarters. Your comments will receive careful consideration at a meeting of the American Chemical Society, see responsible technical committee *Anal. Standards for Laboratory Chemicals*, BDH Ltd., Poole, Dorset, U.K., and the *United States Pharmacopeia and National Formulary*, U.S. Pharmacopeial Convention, Inc. (USPC), Rockville, MD,¹, which you may attend.~~

~~¹¹ Supporting data~~

~~¹¹ The sole source of supply of stannous naphthenate (#32519-A) known to the committee at this time is K&K Division, ICN Pharmaceuticals, Inc., Plainview, NY. If you are available from aware of alternative suppliers, please provide this information to ASTM International Headquarters. Request RR: D02-1202. Your comments will receive careful consideration at a meeting of the responsible technical committee ¹, which you may attend.~~

~~¹² The mixture was prepared using metal naphthenates from the specified batch number of the supplier: lead naphthenate (#101882 of Pfaltz & Bauer, Inc., Stamford, CT); ferric naphthenate (#7124 of Pfaltz & Bauer, Inc.); cupric naphthenate (#72775 of Pfaltz & Bauer, Inc.); manganese naphthenate (#25296 of Pfaltz & Bauer, Inc.);~~

~~¹² Supporting data have been filed at ASTM International Headquarters and stannous naphthenate (#32519-A of K&K Division, ICN Pharmaceuticals, Inc., Plainview, NY); may be obtained by requesting Research Report RR: D02-1202.~~

ANNEXES

(Mandatory Information)

A1. APPARATUS FOR THIN-FILM OXYGEN UPTAKE TEST

A1.1 *High Pressure Reactor*, with lid, cap, and stem is constructed as shown in Fig. A1.1. The high pressure reactor has the same dimensional specifications as the RBOT high pressure reactor (see Test Method D 2272). Therefore, the high pressure reactor for RBOT can be used for this test. However, in the test an aluminum insert and a glass sample container, as specified in A1.2 and A1.3, respectively, are to be used.

A1.1.1 *High Pressure Reactor Body and Lid*, ~~are to be~~ made of 303 stainless steel (see Specification A 314). The high pressure reactor body is to be machined from 76.2-mm (3-in.) solid stainless steel. The interior surface shall be given a smooth finish to facilitate cleaning.

A1.1.2 *High Pressure Reactor Stem* ~~is to be~~, constructed of 303 stainless steel, the stem having an inside diameter of 6.4 mm (0.25 in.) and ~~is to be~~ equipped with a 6.4-mm needle valve. The stem is connected to the center of the lid as shown in Fig. A1.1.

A1.1.3 *High Pressure Reactor Cap (or Closure Ring)* ~~is to be~~, made of chrome-plated steel.

A1.1.4 ~~The high pressure reactor is to be hydrostatically tested~~

A1.1.4 Test the high-pressure vessel for 1 h under a pressure of 3450 kPa (500-psi) at 150°C (200-psi - 200 % of the maximum pressure of in the Thin-Film Oxygen Uptake Test). ~~If after Measure the hydrostatic test (see Practice E 144), the outside~~

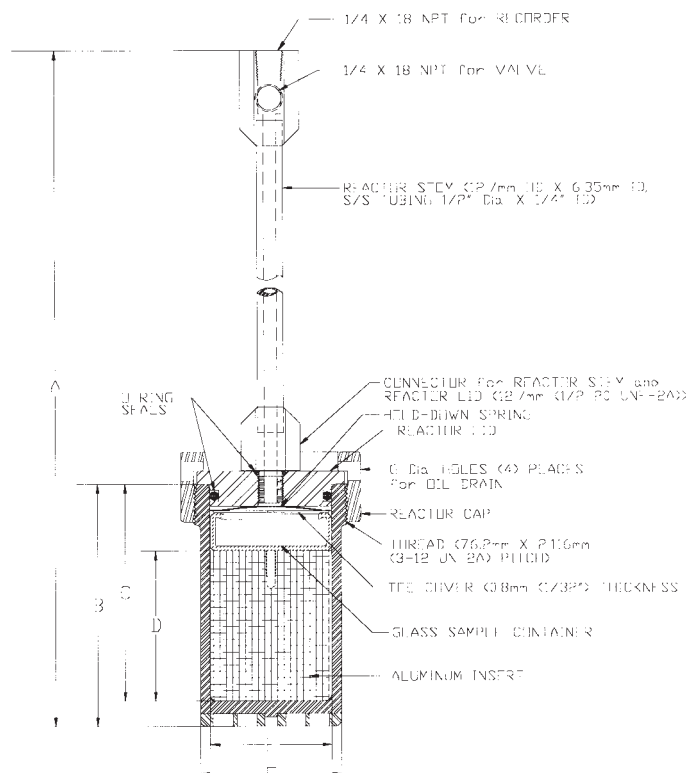

DIMENSIONS	mm	
	mm	In.
A	536	21.10
B	120.6	4.750
C	107.9	4.250
D	74.6	2.937
E	∅50.3/60.6	∅2.375 / ∅2.400
F	∅69.8	∅2.750
G	∅9.5	∅.375

FIG. A1.1 Construction of Oxidation Bomb

diameter of and the midsection length of the high-pressure reactor vessel using a caliper before and after the test. If these are not resumed within 0.25 mm (0.01 in.) of the original dimension when the pressure is released, reject the high-pressure reactor vessel as unsafe. After repeated uses, also reject if the high-pressure vessel appears to be cracked or fractured. After repeated uses (approximately 500 tests), retest the high-pressure vessel at the above specifications to ensure safe operation.

A1.1.5 *O-ring Gaskets*, silicone or a fluorinated elastomer, 50.8-mm (2.0-in.) in inside diameter by 60.3-mm (2.375-in.) in outside diameter.

A1.2 *Aluminum Insert*, in Fig. A1.1, is made of 2024 aluminum rod (see Specification B 211) with 60.3 mm in diameter and 74.6 mm in height.

A1.3 *Glass Sample Container*, in Fig. A1.1, is constructed of borosilicate glass.

A1.3.1 ~~Cover~~ the top of the sample container is to be covered with a 57.2 mm (2.25 in.) diameter TFE-fluorocarbon disk with a 3.2 mm (0.125 in.) diameter hole in the center. The TFE cover prevents sample splash during vessel charge. The disk shall have a thickness of 0.8 mm (0.03152 in.). As an added safeguard against the occurrence of rotational differences between the glass sample container and high pressure vessel, a hold-down spring is required.

A1.3.2 The glass sample container shall have a sliding fit in the high pressure reactor with no excess side clearance. The container alone is to have a maximum wall thickness of 2.5 mm.

A1.4 *Gage*, recording, as shown in Fig. A1.2, or indicating, with a range from 0 to 1400 kPa (~ 200 psi) and graduated in 25 kPa (5 psi) divisions.

A1.4.1 The accuracy must be 2 % or less of the total scale interval.

A1.4.2 Mount recording gages so that their faces are perpendicular to the axis of rotation.

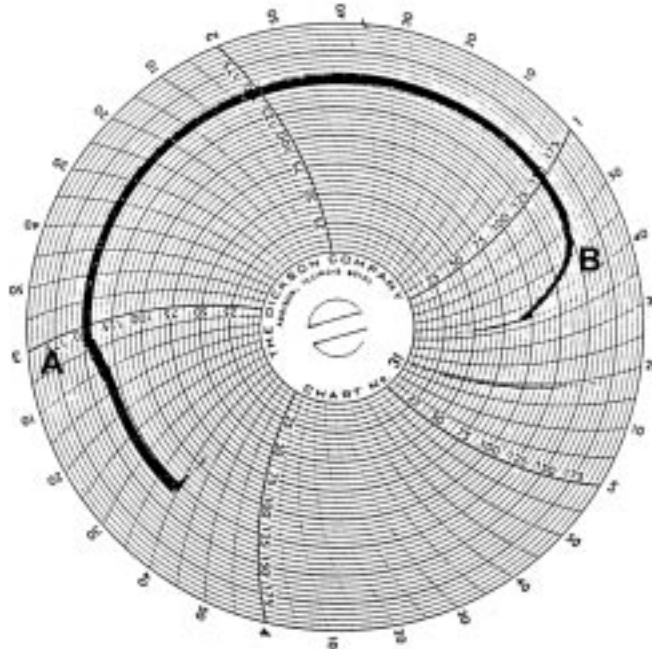

FIG. A1.2 Chart of Recording Pressure Gage (Actual Size = 114 mm (4½ in.))

NOTE A1.1—Clock-wound, round chart recorders should be periodically checked for constancy of the clock works and agreement with standard time.

A1.5 *Oxidation Bath*, equipped with an efficient stirrer and with a suitable device for holding and rotating the high pressure reactor axially at an angle of 30° at 100 ± 5 r/min while submerged in oil to a point at least 25.4 mm (1 in.) below the level of the bath liquid. Keep the oil level at 50.8 mm (2 in.) below the bath cover.

NOTE A1.2—It is recommended that the bath be operated in a hood.

A1.5.1 A bath at least 229 mm (9 in.) deep, filled with 30 L (8 gal) of heavy bath oil per high pressure reactor (petroleum or synthetic oil having a flash point greater than 250°C). Metal block baths are not satisfactory for this service.

A1.5.2 Provide thermal regulation to maintain the bath within $\pm 0.3^\circ\text{C}$ of the test temperature for a period as long as 8 h. There shall be sufficient heat immediately available to bring the high pressure vessels to operating temperature of 160°C within 15 min.

A1.6 *Thermometer*, ASTM Solvents Distillation 102°C thermometer having a range from ~~123°C–177°C~~, 123–177°C, graduated in 0.2°C intervals ~~is to be~~ intervals, and used as prescribed in Specification E 1.

NOTE A1.3—A monthly calibration of the bath fluid temperature device using a calibrated mercury thermometer is recommended.

NOTE A1.4—Thermometers having detached mercury levels or air pockets, or both, within the bulb will not measure temperature accurately. Check thermometers with a 4× or better magnifying glass.

A2. PREPARATION OF THE FUEL COMPONENT

A2.1 This section describes the experimental procedures and the materials for preparation of the fuel component for the Thin-Film Oxygen Uptake. The fuel component is an oxidized/nitrated high boiling gasoline fraction.

A2.2 Prepare the fuel component in accordance with the following procedures:

NOTE A2.1—Gasoline is dangerous when exposed to heat or flame. It can react vigorously with oxidizing materials. A well-ventilated laboratory is required for each of the steps.

A2.3 *Distillation*—Use ASTM certified V-D engine test fuel as the material. A typical V-D fuel contains 40 volume % aromatics, 12 volume % olefins, and 43 volume % paraffins and naphthenates. The boiling range is from 34°C to 209°C, and the density is 0.76 g/mL. Obtain the fuel from the supplier given in ASTM STP 315H.¹³ Obtain a high-boiling fraction (>150°C (normal boiling point)) as residue by vacuum distillation (that is, 5 cm Hg) of the V-D fuel. (Commercially available glass distillation apparatus with a separable distilling head is found satisfactory for this purpose.)

¹³ “Multicylinder Test Sequences for Evaluating Automotive Engine Oils, Part 3: Sequence V-D,” ASTM STP 315, ASTM International.

A2.4 *Oxidation/Nitration*—The oxidation apparatus is shown in Fig. A2.1. Oxidize 100 g of the high boiling fraction at 125°C by bubbling air through the fuel at 100 mL/min. The air contains 2000 mg/kg nitrogen dioxide. During oxidation, permit volatile oxidation products to escape to ventilation. The high-boiling oxidized/nitrated fuel component remains in the oxidation tube. Periodically withdraw a small sample and test it for the acid number (see Test Method D 664). Terminate the oxidation when the acid number of the reaction product reaches between 10 to 15 mg of KOH/g.

A2.5 *Neutralization/Reduction of Product*—Neutralize Acidity—Reduce the acidity of the reaction product from for A2.4 with a saturated solution of reagent grade (99.9 %) sodium bicarbonate (Reagent Grade, 99.9 %) solution. (in Type II reagent water). Place the reaction product in a 500-mL separatory funnel; and shake it with an equal quantity of the sodium bicarbonate solution. At When completed, the end of neutralization, the reaction product has should have an acid number of 2 ± 0.1 . After the sodium bicarbonate solution is drained from the separatory funnel, collect and use the neutralized reacted product as the fuel components.

A2.6 In summary, the fuel component is prepared through oxidation/nitration of a high boiling fraction of ASTM V-D engine test fuel. Control the reactivity of the fuel component by neutralization of the oxidation/nitrated fuel component to an acid number of 2.

A3. PREPARATION OF THE SOLUBLE METAL CATALYST MIXTURE

A3.1 This section describes the materials and the experimental procedures for preparation of the soluble metal catalyst mixture for the Thin-Film Oxygen Uptake Test. The metal mixture contains five metal naphthenates including lead, ferric, cupric, manganese, and stannous naphthenates.

A3.2 *Materials*—Commercially available naphthenates in mineral spirits are used. The materials used are lead naphthenate, cupric naphthenate, ferric naphthenate, manganese naphthenate, and stannous naphthenate. When purchased, lead naphthenate contains approximately 24 wt-% of lead, stannous naphthenate approximately 16 wt-% as tin, and other naphthenate approximately 6 wt-% as the respective metal. Filter these material (0.2 μL TFE filter) under a pressurized filtration system to remove any particulate substances.

A3.3 *Metal Content*—Determine the metal content of each naphthenate by atomic absorption spectroscopy or other equivalent method within $\pm 5\%$ of the mean.

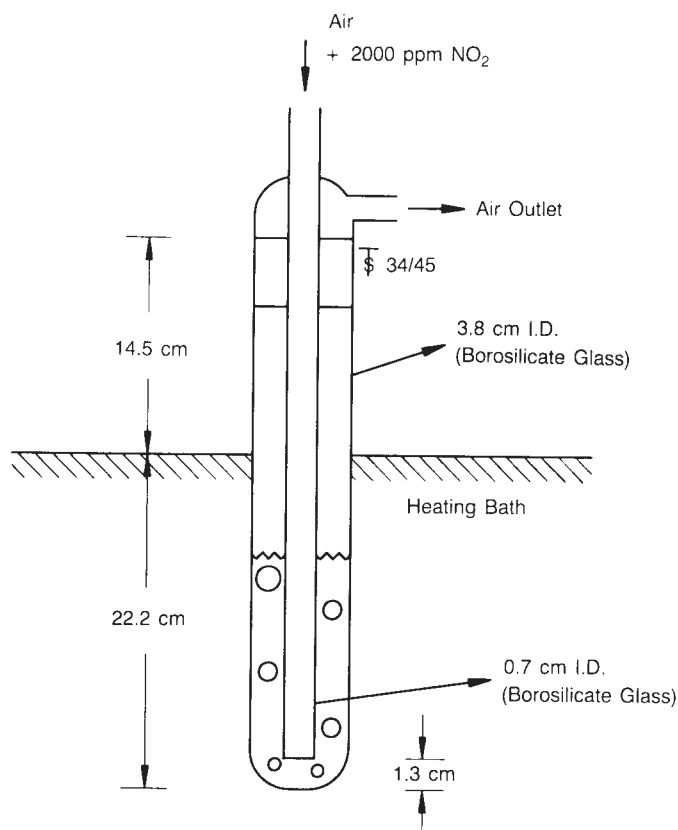

FIG. A2.1 Oxidation Apparatus for Fuel Fraction

A3.4 *Mixing of Metal Naphthenates*—Prepare the soluble metal catalyst mixture by mixing naphthenate components in the proportion so that the metal ratio in the mixture is as specified in A3.5. These components are stirred vigorously to achieve uniform mixing (for example, 100 g of material in a 250 cm³ container should be stirred for 2 h at medium speed using a 2.5-cm magnet).

A3.5 *Composition of the Metals*—The concentration of the total metal content in the mixture should be 0.18 ± 0.02 g of metal/g of mixture. The mixture contains 14.7 ± 0.5 wt-% of lead metal, 1.26 ± 0.01 wt-% of copper metal, 0.75 ± 0.01 wt-% of iron metal, 0.65 ± 0.01 wt-% of manganese metal, and 0.67 ± 0.01 wt-% of tin metal. The ratio of the metal element in the mixture then is approximately as follows:

Metal	Metal Ratio (Weight % of Total Metal Content)
Pb	81.5
Cu	7.0
Fe	4.2
Mn	3.6
Sn	3.7

A3.5.1 Any change

A3.5.1 Composition of the catalyst, in particular the metal composition, must not be changed and must give oxidation results in the Thin Film Oxygen Uptake Test within the precision of the test method using a standard in-house or other at least one reference oil having prior well-established TFOU values.

A3.6 In the future, adjust the composition of the metal catalyst mixture in accordance with the most current data on used oil metal analyses.

A3.7 In summary, prepare the soluble metal mixture from pre-filtered commercially available metal naphthenates including lead, cupric, ferric, manganese, and stannous naphthenates. Determine metal content in each naphthenate by atomic absorption spectroscopy. The metal mixture has a composition as specified in A3.5.

A4. CLEANING PROCEDURE FOR CATALYST SYRINGES

A4.1 This section describes the materials and recommended procedure for proper cleaning of glass syringes used to load the catalyst components and oil sample into the glass sample container. Glass syringes must be cleaned between each use, and it is best to identify each syringe as to the associated liquid component.

A4.2 *Materials*—Commercially available beakers and solvents are found satisfactory for this purpose. The beakers should be approximately 50 mL in size and are used to hold hexane and acetone reagents.

A4.3 Pour approximately 10 mL of hexane and acetone into two separate 50 mL beakers. Completely discharge the 100 µL glass syringes into an appropriate waste liquid container to remove remaining component residue. Withdraw a full syringe of hexane from the beaker of clean hexane, and discharge it into the waste container. Conduct this procedure two more times for a total of three flushes. This same procedure is then immediately followed with the acetone.

A4.4 Immediately after discharging the second and final syringe of acetone into an appropriate waste container, pump the glass syringe plunger several times to dry out the reservoir.

NOTE A4.1—When the plunger tends to leak air when filling, remove the plunger and tap the plastic tip onto a hard flat surface.

A4.5 Withdraw the desired amount of component into the appropriately identified clean glass syringe, and inject into the sample container while weighing the injected amount. If the sample container is segmented, slight overfill of a component can be withdrawn and re-injected to more precisely obtain the final weight of that component.

NOTE A4.2—Periodically inspect the needle tip and orifice to determine potential damage and need for replacement.

NOTE A4.3—Replaceable needles of the desired orifice size, designed to fit the glass syringe, are recommended.

APPENDIX
(Nonmandatory Information)
X1. THIN-FILM OXYGEN UPTAKE TESTS RESULTS

X1.1 The results of the round robin Thin-Film Oxygen Uptake tests made in five cooperating laboratories are given in Table X1.1.

TABLE X1.1 Thin-Film Oxygen Uptake Test, in Min

NOTE 1—Oils A, B, and C are formulated with the same commercial additive package at the recommended treatment level.

Laboratory	Formulated Automotive Engine Oils								
	A ^A	B ^B	C ^C	D ^D	E	F	G	H	I
1	124	139	211	289	200	130	161	59	38
	133	138	199	280	203	128	160	60	37
2	142	137	238	296	219	130	173	65	41
	140	144	221	285	220	133	176	64	41
3	127	140	215	248	183	119	142	56	38
	134	138	221	238	174	111	144	54	36
4	137	135	240	277	217	124	188	65	41
	150	130	272	276	220	116	168	65	48
5	136	161	237	273	207	140	168	60	44
	137	157	250	268	217	140	175	67	45

^A A = Virgin Base Oil.

^B B = Re-refined Oil.

^C C = Paraffin Oil.

^D D to I = ASTM Sequence IIID Engine Test Reference Oils.

ASTM International takes no position respecting the validity of any patent rights asserted in connection with any item mentioned in this standard. Users of this standard are expressly advised that determination of the validity of any such patent rights, and the risk of infringement of such rights, are entirely their own responsibility.

This standard is subject to revision at any time by the responsible technical committee and must be reviewed every five years and if not revised, either reapproved or withdrawn. Your comments are invited either for revision of this standard or for additional standards and should be addressed to ASTM International Headquarters. Your comments will receive careful consideration at a meeting of the responsible technical committee, which you may attend. If you feel that your comments have not received a fair hearing you should make your views known to the ASTM Committee on Standards, at the address shown below.

This standard is copyrighted by ASTM International, 100 Barr Harbor Drive, PO Box C700, West Conshohocken, PA 19428-2959, United States. Individual reprints (single or multiple copies) of this standard may be obtained by contacting ASTM at the above address or at 610-832-9585 (phone), 610-832-9555 (fax), or service@astm.org (e-mail); or through the ASTM website (www.astm.org).